



**SCARAB**  
FAYAT GROUP

## Merlin and Magnum Road Sweepers Hydrostatic Drive



## Operating and basic maintenance instructions



This document contains important Health and Safety advice and must remain with the machine at all times.

**MAIN FEATURES**

1. Water tank
2. Locker
3. Side loading hatch
4. Door open/close ram
5. Rear wander hose (standard)
6. Fuel tank (orientation determined on chassis type)
7. Low pressure water pump and valves
8. Central brush assembly

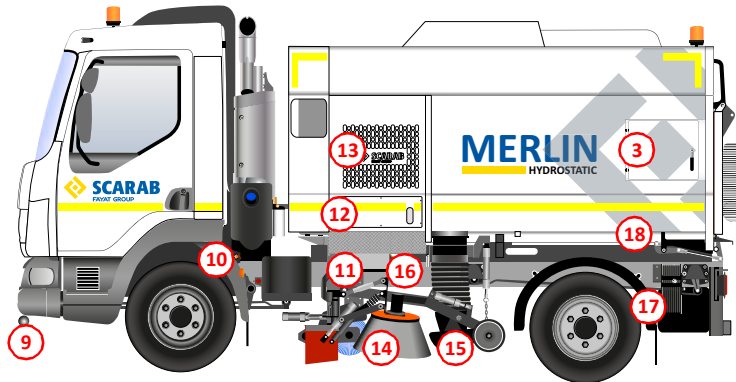
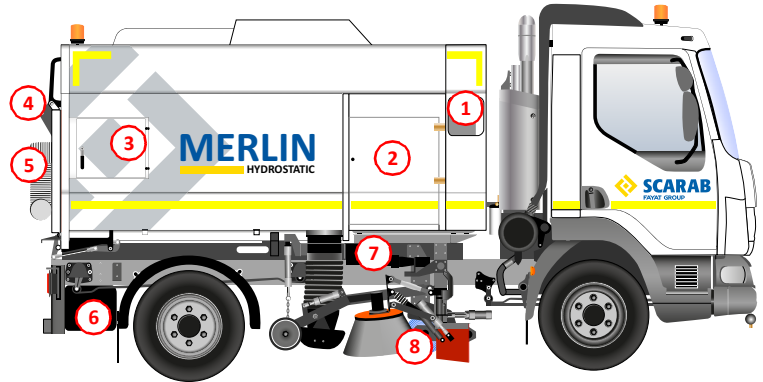

9. Low pressure and/or high pressure spray bar
10. High pressure front spray bar shut-off valve (option)
11. Pneumatic system cabinet
12. Main hydraulic valve block access cover
13. Hydraulic oil cooler location
14. Side brush assembly
15. Suction nozzle assembly
16. Auxiliary hand pump
17. High pressure retractable hose (option)  
(orientation determined on chassis type)
18. Rear door locking mechanism

# Merlin and Magnum Hydrostatic

## Operating Instructions

Incorporating Operator's Basic Maintenance Information

Part No. SCAZ037886

Version: 8.6.01 ..... 22nd June 2020

To get the latest version of this Operator's Manual visit our website [www.scarab-sweepers.com/links/opsmerlmag](http://www.scarab-sweepers.com/links/opsmerlmag)

This manual is published by the Technical Publications Department of Scarab Sweepers Ltd. and every effort is made to ensure that the information it contains is correct at the time of publication. Due to a policy of continuous development, however, the Company reserves the right to alter the specification and to supply when so altered without reference to illustrations and descriptions in this manual.

Scarab Sweepers Limited.  
Pattenden Lane, Marden, Tonbridge, Kent TN12 9QD, United Kingdom  
T: +44 (0) 1622 831 006  
E: [scarab@scarab-sales.com](mailto:scarab@scarab-sales.com) - W: [www.scarab-sweepers.com](http://www.scarab-sweepers.com)  
Registered in England No. 1823459 - VAT No. GB 374 5002 68  
Registered Office: Pattenden Lane, Marden, Tonbridge, Kent TN12 9QD, United Kingdom

Copyright ©2020 Scarab Sweepers Limited

## General information

### **WARNING - Voltage sensitive components.**

**Do not use a boost starter / super star, a boosted start will burn out the vehicles electronic control nodes, if batteries are not charged always use a fresh set.**

### Typical weights, dimensions and capacities

Gross Vehicle Weight (GVW) *	7.5 to 18 tonne
Gross Vehicle Weight (GVW) Magnum *	15 to 18 tonne
Overall Height (hopper lowered)*	3000 to 3500mm
Overall Length *	5640 to 7500mm
Overall Width (brushes stowed) *	2500mm
Hopper Gross Volume *	5.5 <sup>3</sup> to 8.2 <sup>3</sup> Gross
<b>Tank Capacities*</b>	
Fuel Tank *	Typically 100 to 150 litres
Hydraulic Tank	25 litres
Water Tank *	900 litres to 4500 litres

### Noise Levels

In cab	Between 70 - 84 dB(A) dependent on operating speed
External	Maximum L <sub>WA</sub> of 114 dB(A) in accordance with directive 2000/14/EC

### Vibration

Description	All dynamic prime moving components are resiliently mounted to minimise vibrations. In accordance with 2006/42/EC as amended.
Whole body	Equipment does not exceed 0.5 m/s <sup>2</sup> (RMS, weighted)
Hand Arm	Equipment does not exceed 2.5 m/s <sup>2</sup> (VTV)

\* *Dependent upon model*

 *In view of the fact that many variables such as chassis and machine specification affect the weight and dimensions of the finished machine, it is not possible to quote these precise details. If this type of information is required, please contact our Technical Sales staff giving your sweeper's Serial Number.*



CB Radios and other electrical equipment used in the sweeper should be properly suppressed (EMC) to prevent the possibility of interference in the sweeper's electronic system.

### Towing

**Serious damage to the transmission will result if the vehicle is towed while the gearbox is engaged.**

If towing is necessary, it is imperative that the prop shaft is disengaged from the differential or that the rear wheels are clear of the ground before making any attempt to tow the vehicle.

### Identification Plates

The SERIAL NUMBER PLATE is located on the rear face of the left hand suction nozzle spigot. The Serial Number will comprise four numerical digits only (for example 5843). For the location of the vehicle's VIN PLATE and CHASSIS NUMBER, refer to the chassis manufacturers' documentation.

### Limitations of Use

The Scarab Merlin, Merlin XP and Magnum are classified as truck-mounted heavy-duty suction road sweepers and, as such, are intended only for operation in the sweeping and associated roles for which they have been expressly designed. The sweeper bodywork is integrated to the truck/carrier vehicle, and is therefore not demountable.

### Applicability

This manual covers the operating requirements of the Scarab **Merlin**, **Merlin XP** and **Magnum Hydrostatic** sweepers with the CANbus 3 system.

CB Radios and other electrical equipment used in the sweeper should be properly suppressed (EMC) to prevent the possibility of interference in the sweeper's electronic system.

# Table of contents

<i>Title</i>	<i>Page</i>
General information .....	4
Table of contents .....	5
Health and Safety advice .....	6
Hazard awareness .....	7
Safety precautions .....	7
Operating advice .....	8
Safety support props .....	9
The CANbus system .....	10
Main control panel switch functions .....	11
Auxiliary control panel switch functions .....	12
Hopper remote control switch box functions .....	13
The LCD monitor .....	14
Additional controls and instruments .....	15
Brush pressure .....	15
Controls for overhead wander boom .....	15
Operating Modes .....	16
Engaging hydrostatic drive (Manual gearbox trucks) .....	16
Sweeping .....	17
Suction fan boost setting .....	18
Climbing Gradients .....	18
Reverting to normal drive mode .....	19
CNG IVECO with Allison gearbox .....	20
Engage hydrostatic drive .....	20
Disengage hydrostatic drive .....	20
Discharging the hopper (tipping) .....	21
Using the auxiliary hydraulic pump .....	22

<i>Title</i>	<i>Page</i>
Standard wander hose .....	23
Using the standard wander hose .....	23
Using the rear mounted wander hose .....	24
Using the overhead wander boom .....	25
Using the Dust Suppression System .....	26
Filling the water tank .....	26
Using the low pressure water system .....	26
Using the high pressure water system .....	27
Hand lance detergent option .....	28
Retractable hose .....	28
Clearing a blockage in the suction path .....	29
Recommended operator's routine maintenance .....	30
Key maintenance procedures .....	31
Cleaning the suction fan and screen .....	31
Hydraulic oil tank .....	32
Topping-up .....	32
Suction nozzle clearances .....	33
Side brushes and skirts .....	33
Removing and cleaning the water filter element(s) .....	34
Manual greasing and lubrication .....	35
LCD monitor - Options screen .....	36
Button function .....	36
Screen menu description .....	36
Operator's notes .....	44

## Health and Safety advice

In the interests of your health and safety, it is important that the following points are observed at all times.

- Only trained operatives should be allowed to drive or work on this machine.
- Before driving the machine ensure that all relevant machine checks have been carried out, that all equipment is stowed.
- Do not overload the hopper.
- Do not drive the machine with the hopper in the raised position, even if the hopper is empty.
- Always use the safety prop to support a raised hopper, other than during discharging.
- Never work under a raised cab or hopper unless the appropriate safety prop is in position.
- Before operating either the hopper tip or rear door controls, ensure that there is sufficient clearance and that it is safe to do so. Ensure that all personnel are clear of the rear door.
- Before working on the machine, ensure that it is on firm, level ground. Apply the handbrake, stop the engine and remove the ignition key.
- Always wear the appropriate personal protection equipment when operating or working on the machine.
- Before starting the engine ensure that all controls are switched off and that the machine is in neutral.
- Keep long hair, loose clothing and body parts away from moving parts on the machine.
- High pressure water can be hazardous. Always wear suitable face protection when operating the high pressure water pump and when using the lance.
- Do not direct the water jet at other persons. Beware of electrical installations on public buildings and lamp posts etc. Always exercise extreme caution in public places.
- The driver's seat should always be correctly adjusted as to give a good posture when driving. Do not adjust seat whilst driving.
- The mirrors should be adjusted so the driver has good all round view of the machine sides and sweeping equipment.
- When operating the machine in any mode always be aware of objects and people in the immediate vicinity, especially at the rear of the machine when reversing.
- Whatever the situation, remember that the rules of the traffic and road safety must be observed.
- Whilst operating this machine the safety and well being of other people in the immediate vicinity are the sole responsibility of the operator.
- Never ride on any part of the machine other than in the seats in the driver's cab.

 The universal safety symbol as well as red text is used throughout this handbook and when encountered the related information must be adhered to.

 Refers to important information.

 Identifies cautionary information and specific procedures when required.

 Refers to visual examination to confirm the condition or status of a specific item.

Other symbols not shown here may be used throughout this handbook. When encountered, they must be observed.

**Remember, failure to comply can result in serious injury.**

## Hazard awareness

All operators and workshop personnel should be aware of the physical and biological risks that are inherent in the operation of a road sweeper. The risk falls into two main categories as follows:

- Risks represented by the sweeper and its various systems.
- Risks represented by the sweeper's operating environment.

Both have the potential for exposure to a variety of hazards, ranging from hot surfaces to infectious diseases, that can occur during day-to-day operation, while carrying out adjustments or when involved with the general maintenance and servicing activities on the vehicle.

Typical vehicle-related hazards are:

- Exposure to hot surfaces and sharp edges.
- Exposure to moving parts.
- Exposure to various fluids (including some hot and/or pressurised).
- Exposure to surface contamination resulting from general operating conditions.

Typical environmental hazards are:







- Exposure to sharp objects (e.g. broken glass, discarded hypodermic syringes) while operating or working on the vehicle.
- Exposure to various infectious diseases (e.g. Legionnaire's, Weil's, Hepatitis, Tetanus) while operating or working on the vehicle.

## Safety precautions

When using external equipment such as the high-pressure water lance, or when dealing with potentially hazardous situations while sweeping (e.g. unblocking a suction nozzle), always wear the appropriate Personal Protection Equipment (PPE) and exercise extreme caution if required to handle any of the material being swept.

Before working on the vehicle, subject it to a thorough steam cleaning or high-pressure hot water wash using appropriate detergents etc.

Even after taking all reasonable steps to reduce the risk from the hazards described, always wear the appropriate Personal Protection Equipment (PPE) when carrying out sweeping duties or when working on the vehicle. This includes:-

 <b>Safety gloves, including where necessary cut resistant knitted Kevlar.</b>	 <b>Earplugs or ear defenders as appropriate.</b>
 <b>Safety boots or shoes with protective soles and toecaps.</b>	 <b>Eye/face protection, if necessary full face mask with under chin lip.</b>
 <b>Respiratory masks.</b>	 <b>High visibility jackets or waistcoats.</b>
 <b>Overalls or coveralls.</b>	

## Operating advice

Please remember, the information provided in this handbook is designed to ensure that the Scarab sweeper operates both safely and efficiently.

The design of this machine is for the removal of spoil on traffic areas, also litter collection, using the wander hose.

A poorly maintained machine will become unreliable, inefficient and potentially dangerous. Always observe the recommended maintenance and safety related advice provided.

**i** *Unless it is wet or raining, ALWAYS use the low-pressure water spray system when sweeping. This will not only reduce the amount of dust generated, it will also ensure more efficient collection of material. This is because wet material is heavier and will drop more readily from the air stream inside the hopper. If swept dry more of the finer material will pass through the screen, wearing out the fan blades on its way back to the environment behind you.*

### Operators should be trained in the following elements:

- Health and safety observations/notices
- Transit driving
- In-cab and external controls
- Hopper safety/cab prop use
- Brush setting
- Nozzle flap adjustment
- Correct sweeping operations
- Low and high pressure water systems
- Load discharge (tipping)
- Daily, weekly maintenance schedules
- End of day cleaning, ie: suction fan, fan screen and machine body

Operator training can be provided by Scarab Sweepers upon request.

**⚠ The LCD monitor's USB connection is for uploading/downloading information (ONLY) and must not be used for any other purpose.**

**i** *It is the responsibility of employers to carry out their own risk assessment for the machine, operators or other persons using or affected by the machine and equipment.*

**i** *Various safety, hazard and user information labels are fixed to the machine. These must be observed.*

**i** *Only personnel qualified in the relevant disciplines should be allowed to work on any of the machines HYDRAULIC SYSTEM.*

**i** *For information regarding vehicle operation and maintenance, refer to the chassis manufacturer's handbook.*



## Safety support props

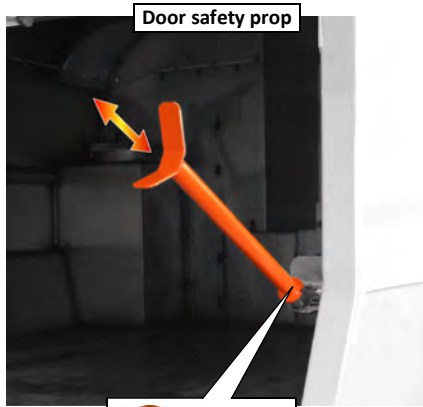

When inserting the door prop, ensure it is correctly positioned in the locating slot

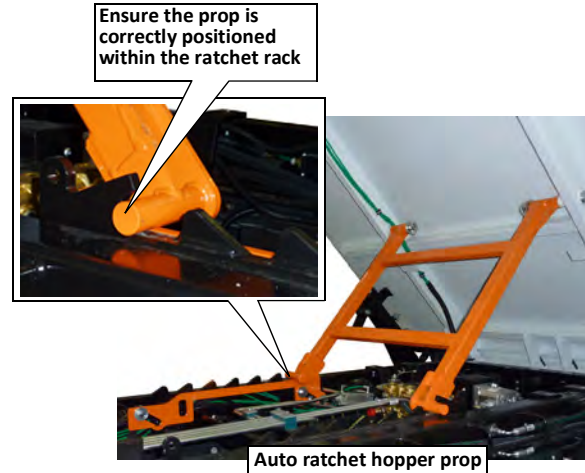

## The CANbus system

The CANbus system comprises two control panels (main and auxiliary) an LCD monitor and a number of control nodes. The system controls and monitors all sweeper functions and maintains a log of various operating parameters such as operating hours and any fault conditions that might occur.

**Switches:** The various types of switch function are grouped in two ways. Firstly they are colour coded as follows:

- Amber** = Electrical functions such as lighting.
- Red** = Critical functions (e.g. Engage Hydrostatic Drive).
- Green** = Sweeping functions.
- Blue** = Water Spray functions.

Each switch illuminates a function-related symbol on the LCD monitor (only installed equipment will be displayed). Each symbol is greyed-out until its switch is activated. When a switch is activated the appropriate symbol will illuminate according to system status as illustrated.

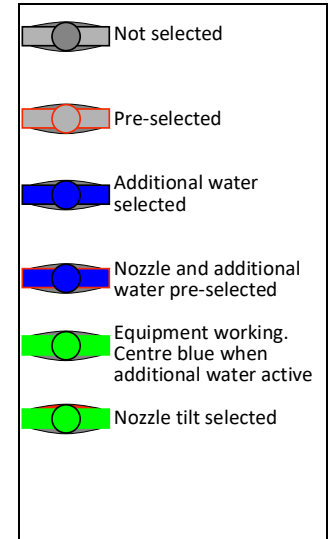
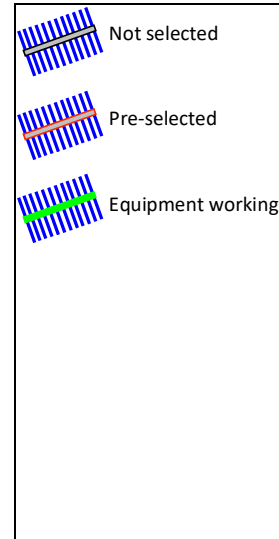
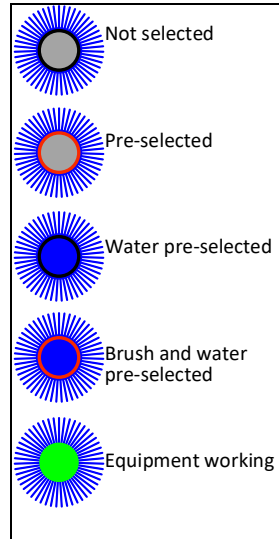
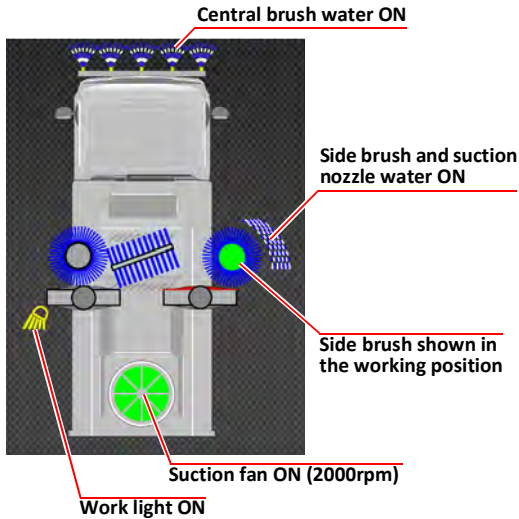

### Main control panel switch functions

**i** Switch functions are described from Left to Right and Top to Bottom.

**F1 F2** F1 / F2 - Press to activate special options.

**⏻** **System Start** - Press to start/stop the system and engage/disengage hydrostatic drive.

**⏮** **Brush Speed (-)** - Press to decrease brush speed. Brush speed remains set until reset.

**⏭** **Brush Speed (+)** - Press to increase brush speed, Brush speed remains set until reset

**⏮** **Left/Right Side Brush** - Press to start the side-brush.

**⏮** **Left/Right Suction Nozzle Raise/Lower** - Press to lower the suction nozzle.

**⏮** **Central Brush (Wide sweep)** - Press to start the central brush.

**💡** **Left/Right Work Light** - Press to turn ON/OFF.

**💧** **Left/Right Side Brush and Suction Nozzle Water** - Press to start the side-brush and suction nozzle dust-suppression.

**💧** **Central Brush (Wide sweep) Water** - Press to start the dust-suppression spray for the central brush.

**⏮** **Increase/Decrease Engine Speed** - Press and hold down to reduce/increase the speed of the vehicles engine. A single press of the either switch will adjust engine speed by 50 RPM. Current engine speed is displayed along the top of the LCD monitor.

**💧** **Left/Right Suction Nozzle - Additional Water (Option)** - Press to start the additional water jets for the suction nozzle.



## Auxiliary control panel switch functions

**Forward/Reverse Lever** - Lift collar to release from Neutral and move the lever in the desired direction to activate the hydrostatic transmission. All active equipment will stop and retract to its stowage position when reverse is selected, redeploying when reverse is disengaged.

 **High Pressure Water Pump (Option)** - Press to start.

 **Suction Fan** - Press to start the Suction Fan (approximately 2000 rpm on standard models and 2900 rpm on high speed models).

 **Cruise Control** - With the accelerator pedal depressed to the desired speed, press to activate cruise control.

 **Nozzle Tilt (Locking Mode)** - Press to tilt the suction nozzle for larger items.

 **Suction Fan 'Boost'** - With the Suction Fan ON, press to activate the fan boost mode. This increases fan speed to approximately 2200 rpm on standard models.

On high speed models fan speed is 3150 rpm. To increase speed to 3400rpm press and hold until a red outer appears on the fan symbol graphic. See Page 14.

 **Favourite Setting** - Press to memorise your preferred sweeping set-up. Hold the switch down until a 'beep' sounds. Thereafter, whenever the switch is pressed at system start-up, the memorised configuration will be automatically pre-selected/restarted. Repeat to over-ride with a new configuration.

**Multi-Function Lever** - ON (deploys all selected sweeping equipment). To stop and raise all sweeping equipment, return the lever to the OFF position.

In the ON position the lever can be used to control the side brushe(s) and suction nozzle(s). These additional positions i.e. Left, Right and Back, return to the central position when released.

The brush and nozzle functions are controlled as follows:

### On Left Hand Drive Vehicles

Move the lever to the left to swing OUT, and to the right to swing IN the side brush(es).

On machines fitted with variable extend and retraction, move the lever momentarily in the desired direction to 'nudge' the brush(es).

### On Right Hand Drive Vehicles

Move the lever to the right to swing OUT, and to the left to swing IN the side brush(es).

On machines fitted with variable extend and retraction, move the lever momentarily in the desired direction to 'nudge' the brush(es).

### Nozzle Tilt Function

Move the lever back to momentarily tilt the suction nozzle or close it from TILT OPEN position.



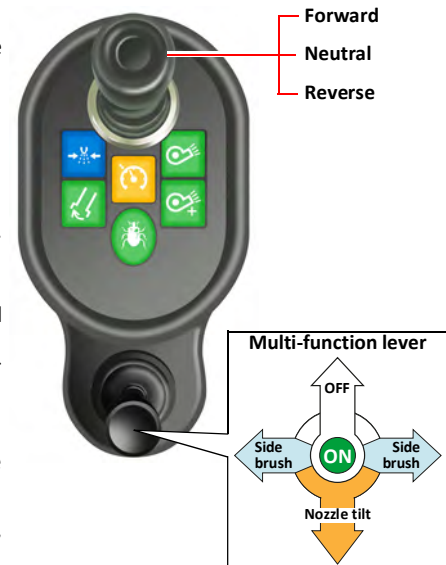



On machines with variable nozzle-tilt, move the lever back to 'nudge' the suction nozzle DOWN from the TILT OPEN position.



### Hopper remote control switch box functions

The hopper Raise/Lower and rear door Open/Close switches are located on the remote control box. This is stowed in the cab, between the driver's seat and door and is connected to a socket via a coiled lead.

- ⚠ In the interest of health and safety and to avoid possible damage to the sweeper or adjacent structures, it is essential that the remote hopper/door controls are not activated from within the cab. Always use these controls outside of the vehicle from a vantage point that affords a good view of the sweeper and its immediate surroundings.**
- ⚠ The hopper prop must always be in the deployed position when working under a raised hopper. Failure to do so could result in serious injury.**
- ⚠ The door prop must always be used when working under a raised rear door.**

-  **Hopper Raise** - Press and hold down to raise the hopper.
-  **Hopper Lower** - Press and hold down to lower the hopper.
-  **Rear Door Open** - Press and hold down until the door is Fully open (at approximately 90° to the rear face of the hopper).
-  **i** *Ensure that the suction fan is OFF. The door cannot open while the fan is running due to the low pressure created within the hopper.*
-  **Rear Door Close** - Press and hold down until the door is fully closed and the latching cycle has finished.
-  **Option**

### SAFETY INTERLOCK

This switch must be pressed in and held before any of the control switches are operated.

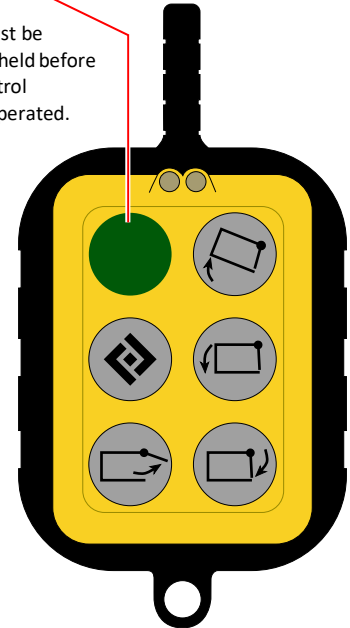

### The LCD monitor

The sweeping monitor displays information on the current status of the sweeper while it is in sweep mode, by indicating which items of equipment are active, plus other relevant information ie: fluid levels, fan speed and temperatures, it also alerts the user to any warnings by means of appropriate flashing symbols and, when appropriate, a warning buzzer. For warnings identified by , stop and investigate the cause. The accompanying illustration shows the range of information/alert symbols that can be displayed, however it should be noted that warning symbols (\*) only illuminate when a specific condition occurs.

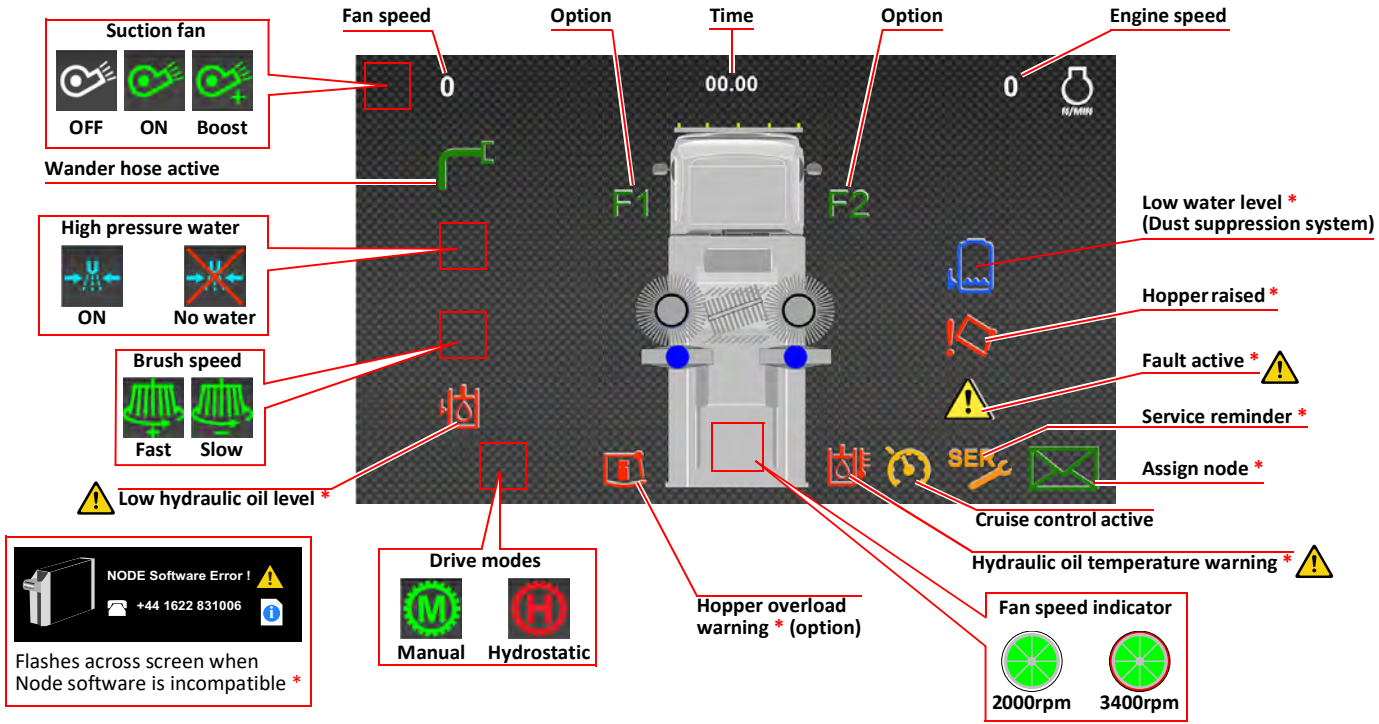

## Additional controls and instruments

### Brush pressure

 Do not exceed a pressure of 2.5 bar when adjusting brush pressure settings. Failure to comply will result in drastically reduced brush life.

- ① - **Air Pressure Regulator** - Used to adjust the amount of up/down thrust applied to the brush(es) ✕.
- ② - **Air Pressure Gauge** - Indicates the amount of pressure being applied to the brush(es) ✕.
- ③ - **Central Brush (Wide sweep) Pressure Switch** - Turns function ON/OFF.
- ④ - **Side brush Pressure Switch** - Turns function ON/OFF.

✕ This function is only effective while the relevant brushes are deployed.

Side brush controls  
mounted in cab

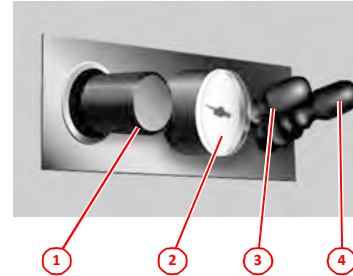

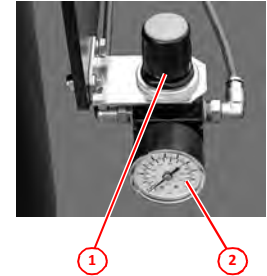

Central brush controls  
mounted on subframe



### Controls for overhead wander boom (option)

These are mounted just above the wander boom handle and consist of two buttons for selecting fan extra-boost speed (3rd Speed) of approx. 2500 rpm and/or the low-pressure dust suppression water supply. Engine speed will automatically increase to 1500 rpm when fan 3rd Speed is selected.

-  The fan and engine speed do not change if high speed fan option is fitted.
-  Push button in to activate (button locks-in). Turn in direction of arrows to release.



## Operating Modes

 Refer to the health and Safety Information on Page 6

There are two driving modes, Normal and Hydrostatic (Sweep), these are selected using the sweep mode switch  on the control panel. The selected drive mode is indicated on the LCD monitor as follows:

 **Normal Drive Mode**

 **Hydrostatic (Sweep) Drive Mode**

 **Reducing Noise Levels and Fuel Consumption:**



*Although it is important to always operate within the engine's optimum speed range, there are times when it is possible to reduce engine speed to the lower end of this, thereby reducing noise levels. This is most beneficial when sweeping at night, or in areas sensitive to noise pollution. Sweeping at reduced engine speeds can be achieved most satisfactorily when sweeping light or sparsely distributed materials. Experience will enable the operator to vary engine speed, according to sweeping conditions, without affecting sweeping performance.*



It should be noted that the operator also benefits from reduced noise levels within the cab and that any reduction in engine speed, also results in a corresponding reduction in fuel consumption.

## Engaging hydrostatic drive (Manual gearbox trucks)

 **Engine ON and air tanks full before attempting to engage hydrostatic drive mode. The hydrostatic gearbox will not engage unless the vehicle is stationary.**

1. Switch on the hazard warning beacons.
2. Stop the vehicle, apply the parking brake and select Neutral.
3. With the engine running, depress the clutch pedal and press the Sweep Mode switch. 





When hydrostatic drive engages, the symbol  will change to the  and a number of symbols, representing the installed sweeping equipment will appear superimposed on the truck graphic, displayed on the LCD monitor.

 *If the Hydrostatic Gearbox fails to engage properly, the  symbol will flash and a buzzer will sound intermittently, press the Sweep Mode switch and release the clutch. Drive the vehicle slightly forward and repeat steps 2 and 3.*



4. Select the highest forward gear available and release the clutch pedal. The vehicle is now in hydrostatic drive and may be driven using the hydrostatic control lever (See Page 12) without use of the vehicles clutch or gear lever.





## Sweeping

1. Switch on suction fan  (approx. 2000 or 2900 rpm) or 'Boost'  (approx. 2200, 3150 or 3400 rpm) as required. If 'Boost' is selected (See Page 18) remember that increased engine speed might be necessary. Fan speed can be confirmed by referring to the LCD screen.
2. Select the desired configuration of sweeping equipment and water sprays if required, either manually or by pressing the Favourite Settings button  to recall your preferred arrangement. Switch on work lights  if required.

 **Be aware that too much reduction of engine speed can adversely affect suction performance.e vehicle is stationary.**

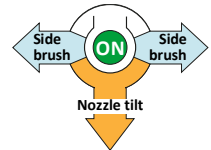
3. Move the multi-function lever (located on the auxiliary control panel) to the ON position to start and deploy the pre-selected sweeping equipment. To stop and stow the sweep gear, return the lever to OFF. The sweeping equipment will raise to the stowed position and all water spray jets will stop, this will also occur automatically as soon as REVERSE is engaged, reverting to the original configuration as soon as REVERSE is disengaged.
4. Operate the multi-function lever to swing the side brushes OUT. The multi-function lever can also be used to control nozzle-tilt (See Page 12 for operating details).
5. Set the required engine speed by means of the engine speed controls   on the main panel (normal operation can be conducted at between the default engine speed and 1800 rpm according to prevailing conditions). The switches adjust engine speed up or down in 50 rpm increments or can be held down for greater adjustment.
6. Select Forward drive using the hydrostatic control lever, release the parking brake and slowly depress the throttle pedal to move and start sweeping.



 **Whatever the situation, remember that the rules of traffic and road safety must be observed.**



 **Hydrostatic Braking - Sweep Mode Only.**

*This allows the vehicle to slow-down rapidly when the accelerator pedal is released, eliminating the need to use the footbrake in certain conditions. Even though this feature is available it is still advisable to always use the footbrake when stopping.*

 **The foot-brake must always be used for emergency braking. Never press brake and accelerator pedals at the same time.**

## Suction fan boost setting

When required, boost settings are available for the suction fan. This increases fan speed and is used when sweeping heavy material. To operate the fan at the Boost settings, carry out the following procedure:

1. Press the suction fan 'Boost' switch . See Page 12.
2. Adjust engine speed as necessary, by means of the controls   on the main panel, until the fan is at the desired rpm using the lowest engine speed to achieve this.



## Climbing Gradients

When sweeping up hill it might be necessary to increase engine speed to maintain sweeping performance. It is advisable to do this before you start to climb the hill.

The amount of increase will depend on a range of variable factors:

- (a) The individual characteristics of the engine.
- (b) The current hopper load.
- (c) The current sweeping load (e.g. light or heavy material).
- (d) The angle of the gradient.

 To increase engine speed, do one of the following:

- **Use the engine speed-setting controls**  . This method is most useful when a prolonged increase in engine speed is required.
- **Use the throttle pedal.** To temporarily over-ride the pre-set engine speed, up to a maximum defined in the software programming. This method is more convenient for brief increases in engine speed as engine speed will automatically revert to the pre-set value when the throttle pedal is returned to its previous position.

## Reverting to normal drive mode

1. Move the multi-function lever (located on the auxiliary control panel) to the OFF position. This will stop and raise all sweeping equipment to the stowed position. The sweeping equipment symbols displayed on the LCD monitor will change back to grey, indicating that they are no longer active.

 *For safety reasons, if the multi-function lever is left in the ON position at this point the sweeping equipment will not activate when sweep mode is later resumed. If this occurs the lever will need to be placed in the OFF position when sweep mode is resumed.*







2. Switch the suction fan OFF. 

3. Bring the vehicle to a complete stop and apply the hand brake. Place the hydrostatic control lever in neutral.

 **Whatever the situation, remember that the rules of traffic and road safety must be observed.**

4. Depress the clutch (engine speed will drop to idle).

5. With the clutch depressed, press the sweep mode switch , holding it down until the drive symbol changes. When hydrostatic drive disengages, the symbol  will change to the . The symbols displayed on the LCD monitor representing the installed sweeping equipment will also extinguish.

 *If the hydrostatic gearbox fails to disengage properly, the  will flash and a buzzer will sound intermittently. Press the sweep mode switch and release the clutch. Drive the vehicle slightly forward and repeat steps 2, 3 and 4.*





6. Select vehicle's neutral gear and release the clutch.

 *As soon as you no longer represent a hazard turn off the beacons*

## CNG IVECO with Allison gearbox - Engaging and disengaging hydrostatic drive

 **Engine ON and air tanks full before attempting to engage hydrostatic drive mode.**  
**The hydrostatic gearbox will not engage unless the vehicle is stationary.**



### Engage hydrostatic drive

1. Switch on the hazard warning beacons.
2. Stop the vehicle, apply the parking brake,
3. Press neutral button 'N' on the Allison transmission selector. 
4. Keep brake pedal pressed, this will keep engine revs at tick over.
5. Select hydrostatic mode using the sweep mode switch .
6. Ensure that you are in hydrostatic mode, this symbol  should not be flashing on the LCD monitor.
7. Keep brake pedal pressed so engine revs are below 900rpm.
8. Press the drive button 'D' on the Allison transmission selector. 
9. On the dash gear 4 will show.  
 If the gear 4 is flashing on the dash then the Allison gearbox has not engaged.  
 Press the sweep mode switch  to disengage hydrostatic mode.  
 Repeat process from step 3.
10. Hydrostatic drive is established when the gear 4 on the dash is not flashing.



Sweeper is now in hydrostatic drive mode and you can prepare for sweeping.

### Disengage hydrostatic drive

1. Stop the vehicle, apply the parking brake.
2. Press the brake pedal to lower the engine revs.
3. When engine revs are below 900rpm, press the neutral button 'N' on the Allison transmission selector. 
4. Press the sweep mode switch  and  will show on the LCD monitor.



Sweeper is now in normal drive mode and you can prepare for transit driving.

## Discharging the hopper (tipping)

 **In the interest of health and safety and to avoid possible damage to the sweeper or adjacent structures, it is essential that the remote hopper/door controls are not activated from within the cab. Always use these controls outside of the vehicle from a vantage point that affords a good view of the sweeper and its immediate surroundings.**

 **The door prop must always be used when working under a raised rear door.**

 **The hopper prop must always be in the deployed position when working under a raised hopper. Failure to do so could result in serious injury.**

1. With the vehicle correctly positioned in the discharge area. Proceed as follows:

 **Before raising the hopper, ensure that the vehicle is on firm, level ground and that there are no overhead obstructions.**

2. Engine running. Handbrake ON. Vehicle in Neutral. Multi-function lever OFF.

3. Select Hydrostatic drive. See Page 16.

 *The safety interlock must be pressed in conjunction with the following buttons.*

4. Open the rear door fully. 

5. Raise the hopper fully. 

6. With the load fully discharge, stow the hopper prop and lower the hopper completely. 

 **Before closing the door, ensure that the door seal, and mating faces on the hopper, are free from any foreign matter that might damage the seal or adversely affect the sealing function.**

7. Close the rear door  making sure the locking mechanism has fully engaged.

8. Select Manual drive: See Page 16, and move vehicle clear of discharge area.



## Using the auxiliary hydraulic pump

In the event of hydraulic system failure, an auxiliary (manually operated) hydraulic pump is fitted, to enable the rear door and hopper to be operated. This is located on the left hand side of the vehicle, adjacent to the hopper suction spigot. The pump handle is stowed in the cab.

*It should be noted that it will require a substantial number of pumping cycles to complete the following operations. The assistance of a second person is highly recommended.*

1. Engine OFF. Handbrake ON.
2. Turn ON the ignition (do not start the engine). Select sweep mode  from the main panel.
3. Insert the pump handle.
4. Pressing the required function button on the Remote control and hold, while operating the pump handle.

 **Never work under a raised hopper or rear door unless the appropriate safety prop is in the deployed position.**

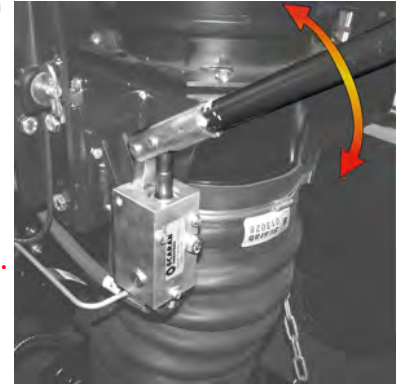





## Standard wander hose

The wander hose is used to suck up objects in areas that the sweeper is unable to access for example, drain inlets, under benches, etc.

### Using the standard wander hose

**i** Vehicle in hydrostatic drive. Drive control lever in neutral. Handbrake On. Sweep mode and multi-function lever OFF.

1. Remove the wander hose ① attached to the rear door.
2. Remove either of the blanking plate ② from the rear door aperture and stow on the spare fasteners below.
3. Attach the wander hose over the exposed aperture ③, using the captive fasteners.
4. Suction fan ON. 

**i** For situations requiring maximum suction power, for example when removing stubborn objects etc., select fan 'boost' 

**i** When finished, turn all controls OFF and return the wander hose to its stored position, replace the blanking plate

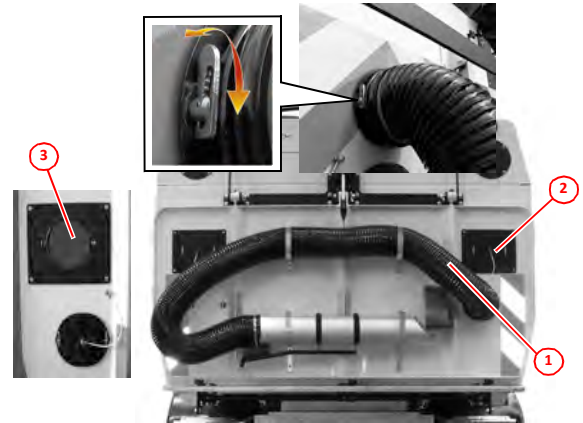

## Rear mounted/Overhead wander booms



### Using the rear mounted wander hose

**i** Vehicle in hydrostatic drive. Drive control lever in neutral. Handbrake On. Multi-function lever ON.

1. Suction Fan ON. 
2. Unhook the wander hose boom ① from its stowed position ②.
3. Demount the hose assembly ③ from its stowage and swing-out the entire assembly to the required position.
4. Turn the wander hose control ④ ON (always mounted on the drive side).

**i** If water suppression is required place the multi function lever in the ON position.

**i** On vehicles equipped with pneumatic assist, use the UP/Down controller ⑤ (always mounted on the drive side) to unhook the wander hose.

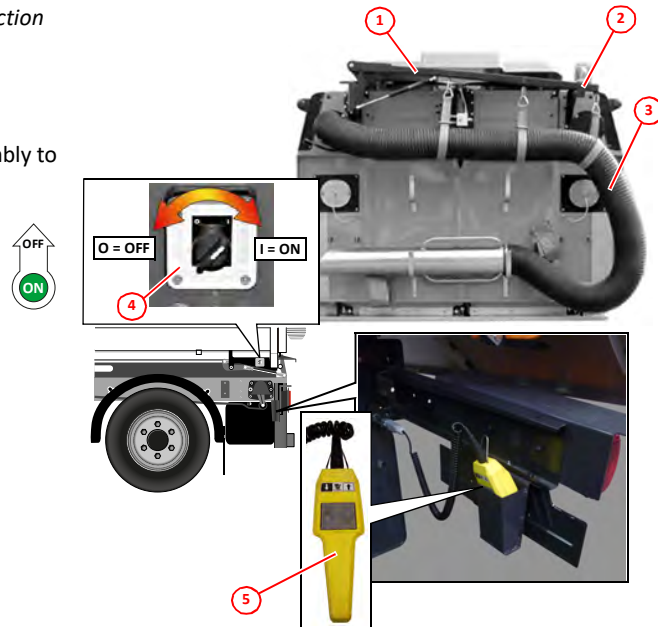

**i** For maximum suction power, select fan 'boost'. 





### Using the overhead wander boom

**i** Vehicle in hydrostatic drive. Drive control lever in neutral. Handbrake On. Multi-function lever OFF.

1. Unlatch the hose assembly ① from its stowage and attach suction tube ② (extra tubes can be added to give greater length).
2. Unhook the overhead boom from its stowed position ③.
3. Suction Fan ON. 
4. Increased suction, use the fan 'boost'. 

**i** If water suppression is required place the multi function lever in the ON position and use button ④ on the hose assembly control block ⑤.

**i** An extra fan speed for the overhead boom can be selected, use button ⑥ on the hose assembly control block ⑤.

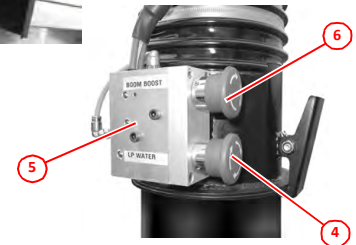
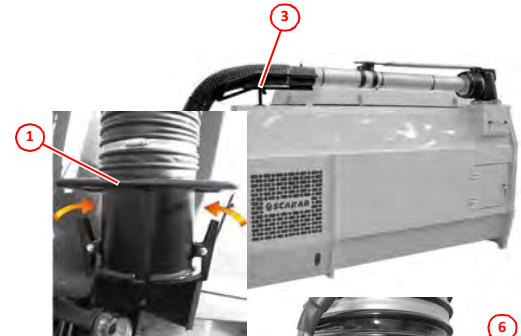

## Using the Dust Suppression System

### Filling the water tank

Attach the appropriate coupling and water hose to the filler aperture ① and fill until the blue float reaches the top of the water level sight tube ② (use clean water).

### Using the low pressure water system

The low pressure water is used on the, side brush(es), suction tube(s), and central brush (wide sweep). To operate any of these functions the relevant button(s) on the main panel must be selected when in sweep mode.

A shut-off valve is positioned between the water tank and the water strainer and must be open when the system is in use ③.

The side brush(es) are fitted with shut-off valves ④.

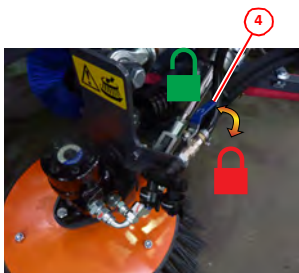

 **It is vital that the water system is drained totally if the air temperature is expected to fall to 0°C or below.**

**Fully draining the system** - Open tank drain valve ⑤. Open low pressure water shut off valve ③. Open water strainer valve ⑦. Open all brush shut-off valves ④. When the water has stopped draining from the various taps. Shut valve ③ and remove the water strainer ⑥. Start the engine and put into sweep mode, activate all the low pressure water functions on the main control panel. When the water has stopped flowing from the spray nozzles, turn off all the low pressure water functions from the main control panel and exit from sweep mode. Switch the engine off.

 *Due the customers requirements, other water features may be present but not mentioned in this publication.*

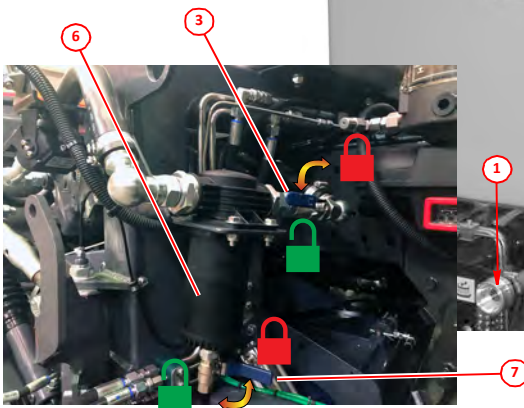





## Using the high pressure water system (option)

- ⚠ High pressure water can be hazardous, always wear goggles or suitable eye/face protection. Exercise extreme care when using the lance, do not direct the jet at other people or electrical connections. Failure to comply can result in serious injury.**

The high pressure water is used on the following options:

- Front spray bar ①.
- Suction tube boost spray bar ②.
- Suction fan wash assist\* ③.
- Hand lance and retractable hose\* ④. See page 28.

To operate any of the above options the vehicle must be in hydrostatic drive, with sweep mode ON . Press the high pressure water switch  on the auxiliary control panel and open the appropriate valve(s) for the function(s) required.

**i** Fan wash assist is only an aid to fan cleaning. It is recommended that this option is used immediately following a days sweeping. The fan should always be cleaned in accordance with the recommended operators routine maintenance.

- ⚠ Due to the possibility of excess water and loose material being ejected via the hopper hood when the suction fan is restarted, this procedure should only be carried out at an appropriate location.**

\* These options always fitted on the drivers side.

Valves for the various options

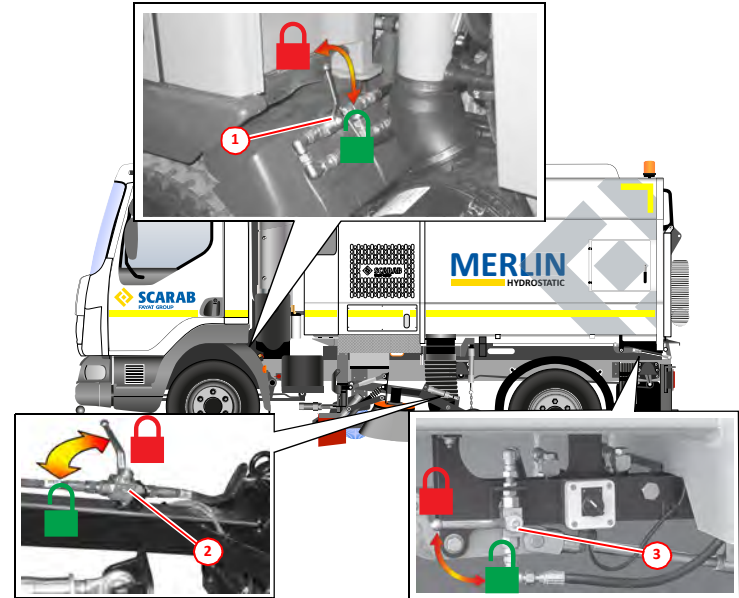

### Hand lance detergent option



With the hand lance in use, check that the detergent container ⑤ has sufficient fluid. Turn on the control valve ⑥. Adjust the spray pattern valve ⑦ on the hand lance to achieve desired effect.

### Retractable hose

The hand lance is attached to a 13 metre long rubber hose fitted to a hose reel ⑧. When extending the hose, a ratchet mechanism allows the reel to lock in place. Further extending past the ratchet allows the reel to retract. The position of the hose reel and hand lance is determined by the machine specification.

In certain cases the hand lance is fitted with a quick release coupling ⑨.

 It is vital that the water system is drained totally if the air temperature is expected to fall to 0°C or below.

**Draining the system** - See Page 26. Remove water strainer . Open pump drain valves  and .

 The water pump should NEVER be permitted to run dry.

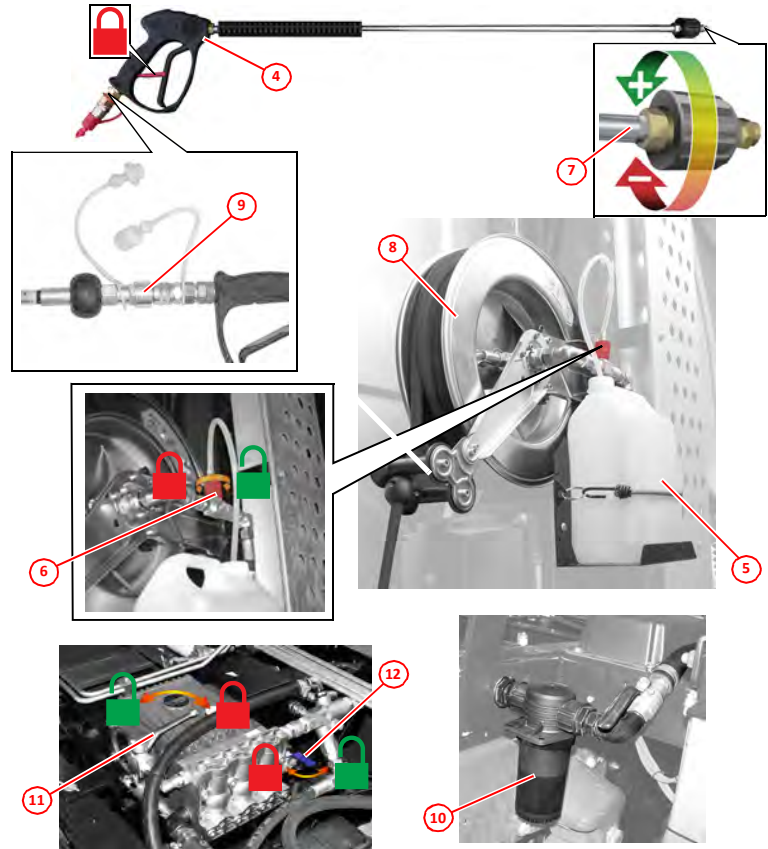



## Clearing a blockage in the suction path



A blockage in the suction path will be indicated by a trail of material behind the vehicle.

Use the following instructions and the diagram opposite to locate and remove the obstruction:-

1. With all sweep equipment retracted and stowed.
  - ⚠ Never raise the hopper where the load it contains or the ground you are on could cause the vehicle to become unstable.**
2. Raise the hopper , deploying the safety prop. Stop engine. Remove ignition key.
- ⚠ The hopper prop must always be in the deployed position when working under a raised hopper. Failure to do so could result in serious injury.**
-  3. Visually check the suction path to determine the nature and location of the blockage. If no blockage is present, further investigation of the suction system will need to be carried out.
4. If the blockage is still present, use a suitable implement (a stout length of wood is ideal), to remove the obstacle by pushing it downwards.
  - ⚠ Always be aware of the risk from sharp objects and never place your hands into the blockage, even when wearing gloves. Exercise extreme caution when handling any items removed from the suction system, keeping such activities to the absolute minimum.**
5. Stow the hopper prop and lower the hopper  but do not start the suction fan at this stage.
6. Move the vehicle sufficiently to expose the cause of the blockage. Stop the vehicle, apply the parking brake and remove the ignition key. Carefully isolate the blockage and if appropriate, place it in the hopper via the side loading hatch.
7. Resume sweep mode. Lower the suction box and switch on the fan. Ensure the suction is correctly functioning.
8. Return to the start of the trail created by the blockage and continue sweeping..

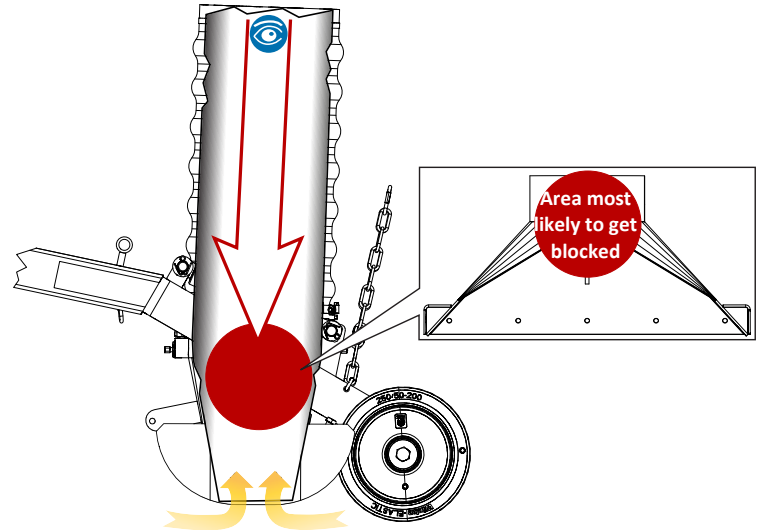





## Recommended operator's routine maintenance

It is important that the following routine maintenance procedures are carried out as directed. This will help to ensure that your Scarab sweeper performs at the optimum level of safety and efficiency. Refer to the paragraphs immediately following this schedule and to the Table of Contents for more detailed information. For chassis servicing/maintenance, refer to the chassis manufacturers information.

Maintenance procedures	Daily actions		Weekly
	Before use/	After use	
1. Check vehicle/body for safety. All lighting equipment, tyres, fuel, oil, coolant, brake fluid, windscreen wash and water tank level.	✓	✗	✗
2. Check hydraulic oil level and inspect system for signs of leaks. Check oil cooler is clean.	✓	✗	✗
3. If vehicle not previously used by YOU, check suction fan is clean.	✓	✗	✗
4. Check brushes/skirts for wear or damage. Remove entangled items, e.g. string are strapping. etc.	✓	✗	✗
5. Check suction nozzle flaps for damage/correct ground clearance.	✓	✗	✗
6. Check water spray jets for blockages.	✓	✗	✗
7. Check that all equipment is securely stowed and brushes are retracted.	✓	✗	✗
8. Wash vehicle, particularly hopper screen, surrounding ledges and area above. Leave hopper door partially open, to allow air to circulate.	✗	✓	✗
9. Wash oil cooler, ensuring that the fins are clean.	✗	✓	✗
10. Lubricate as appropriate, all brush links, pivot and nozzle wheel.	✗	✓	✗
11. Remove/clean the L-P and H-P water filter elements.	✗	✓	✗
12. Clean the suction fan thoroughly, using the scraper provided and high pressure water (See Page 31).	✗	✗	✓

Maintenance procedures	Daily actions		Weekly
	Before use/	After use	
13. Conduct a thorough inspection of the fan assembly to verify its condition. Report any defects (See Page 31).	✗	✗	✓
14. Grease pro-shaft and check wear of universal joints (U/Js).	✗	✗	✓
15. Grease hopper ram (Top and bottom).	✗	✗	✓
16. Visually check entire machine for wear/damage.	✗	✗	✓
17. Check wiring and hoses for security of attachment and signs of wear and damage.	✗	✗	✓
18. Check wear in suction tubes and deflectors in hopper.	✗	✗	✓
19. Check seals on hopper door, side hatches and suction tubes.	✗	✗	✓
20. Check oil level in H-P pump, top-up if needed.	✗	✗	✓
21. Grease all points (See Page 35).	✗	✗	✓
22. Check subframe to chassis fixing brackets	✗	✗	✓



 **It is vital that the water system is drained totally if the air temperature is expected to fall to 0°C or below.**



 *In frosty weather leave the hopper slightly raised with the rear and side door partially open.*

 *The foregoing are general recommendations only. Requirements vary from territory to territory and depend on vehicle usage/operating conditions. IF IN DOUBT, CONSULT YOUR NEAREST DEALER.*

## Key maintenance procedures



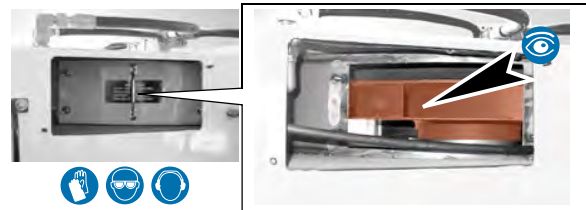

### Cleaning the suction fan and screen

-  **Failure to comply with the following could result in serious injury.**
-  **Before working on the machine position it on firm, level ground and apply handbrake.**
-  **The fan is an extremely heavy rotating mass. never attempt to slow or stop its rotation by using the hands or by inserting any item into the fan chamber, even at low speeds.**

1. Turn engine OFF. Remove Ignition key. Use a suitable platform to enabling you to reach the area above the rear door.
2. With the fan stationary, remove the outer and inner inspection covers from the hopper to expose the fan.
3. Using the special scraper, thoroughly clean all parts of the fan. A steam-cleaner or high-pressure water from a remote source will greatly assist in cleaning severely contaminated fans.
4. Refit the inspection covers and open the rear door . Lower the screen. Wash the screen using steam or high-pressure water. Raise the screen and close the rear door. 



Please pay particular attention to inner curve of blade and also the centre of the unit where dirt accumulates around the hub area.

-  **Never work under a raised rear door unless the prop is in the deployed position.**
  -  **Loose particles from the cleaning process can be ejected via the hopper cover when the fan is restarted, ensure that all personnel are clear before restarting.**
5. Start engine. Select sweep mode . Fan ON .
  6. With the rear door shut, direct additional water on to the screen below the fan inlet cone, from an open side-access flap, until only clean water is expelled from the fan casing.

## Hydraulic oil tank

It is advisable to top-up the Hydraulic oil level when the system is cold.

**i** The hydraulic oil tank gauge is fitted with low level sensor. If the oil level drops too low the brush gear will be lifted and a warning symbol will be displayed on the LCD screen and a buzzer will sound.

### Topping-up

1. Raise the hopper fully. 

**⚠** The hopper prop must always be in the deployed position when working beneath a raised hopper. Failure to do so could result in serious injury.

2. Using the appropriate size spanner, remove the filler cap **1**.

3. Top-up with HPL 32 or an equivalent hydraulic oil to the appropriate level.

**i** Pay particular attention the hopper orientation as indicated on the level label when filling.

4. Replace the filler cap.

5. Stow the hopper prop and lower the hopper completely. 

### Oil tank components

- 1** - Fill/breather cap
- 2** - Return filter
- 3** - Sight glass
- 4** - Suction filter





## Suction nozzle clearances

Inspect the suction nozzle flaps to verify that they are in good condition and do not show excessive wear. Adjust as necessary to achieve the correct flap to ground clearances. The factory settings are:

- Inboard Side Flap = 15mm
- Front Flap = 20 mm
- Rear Flap = 15 mm

**i** These clearances are based on the factory set-up. For some operating conditions, it might be found that, alternative clearances are preferred

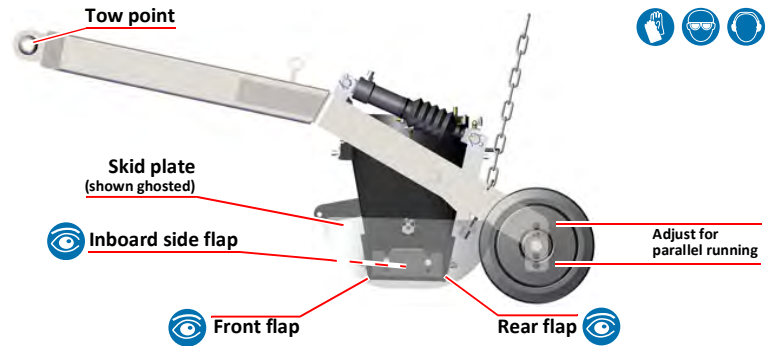

## Side brushes and skirts

**⚠ Do not attempt to alter brush settings while brush is rotating.**

An effective brush set-up ensures good sweeping performance. The following settings produce excellent results in most conditions. Experience will determine if other settings are better suited to specific conditions.

1. Vehicle stopped, handbrake ON, sweep mode ON, activate the desired brush(es) in their working positions.
2. Switch OFF ignition and remove the key.

**⚠ Before proceeding ensure people and objects are clear of the brush area.**



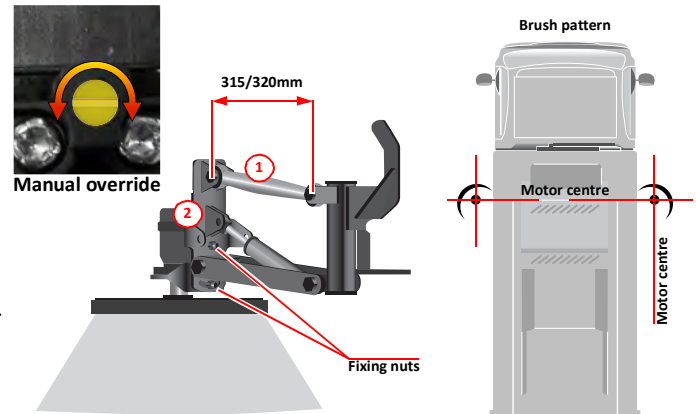

3. Locate the appropriate valve(s) in the pneumatic cabinet and activate the manual override to allow the brush(es) to extend.
4. Adjust the top link ① and/or the motor plate ② until the brush is at the correct contact with the road surface. Re-tighten any items slackened during adjustment.
5. Re-start vehicle, stow all sweeping equipment activated for adjustment.



## Removing and cleaning the water filter element(s)

Both the low-pressure and, if fitted, the high-pressure water pump are fitted with strainers to ensure that foreign matter does not enter the pump. The following steps detail the recommended cleaning procedure.

**i** It will be necessary to place the shut-off valve(s)  in the closed position.

1. Unscrew the filter bowl  clockwise from the housing  and remove the element .
2. Wash out the element with clean water or replace if too contaminated.
3. Before re-assembling the unit, apply some grease to the O-seal  to ensure a water-tight fit for the filter bowl.
4. Refit the element and filter bowl.
5. Return the shut-of valve(s) to the ON position.

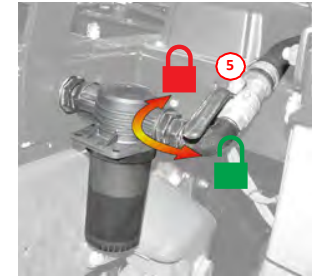
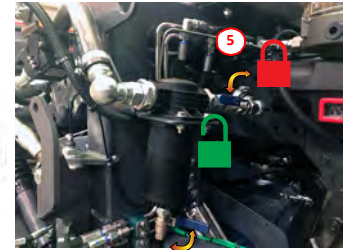
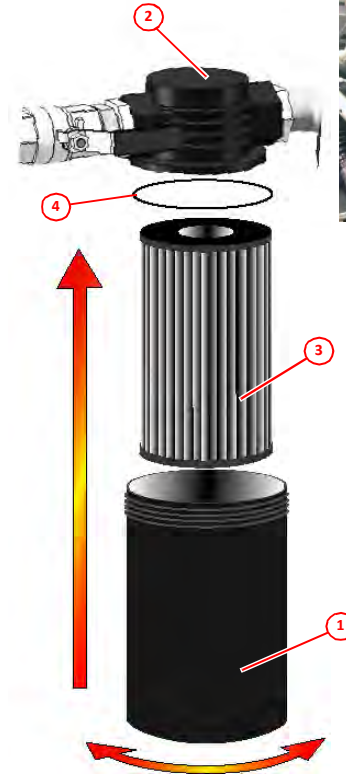

## Manual greasing and lubrication

Carry out manual greasing in accordance with the appropriate schedule on Page 30 and by referring to the accompanying diagrams shown here.

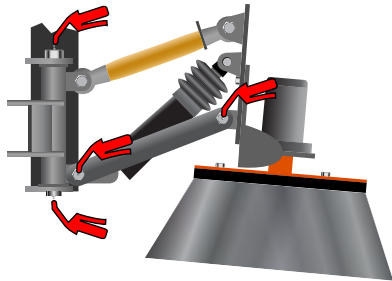

Side brush assemblies

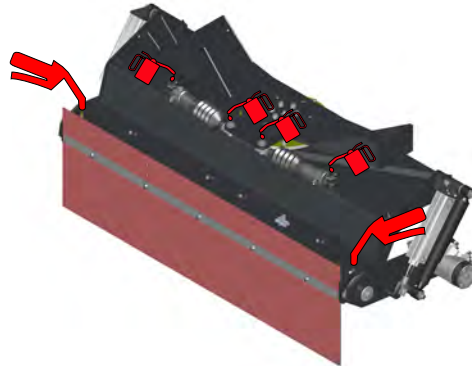

Central brush (wide sweep)

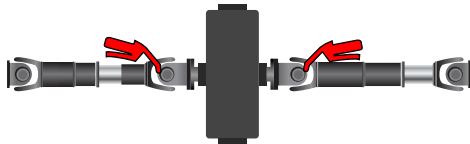

Hydrostatic gearbox prop shafts



Suction nozzle assembly

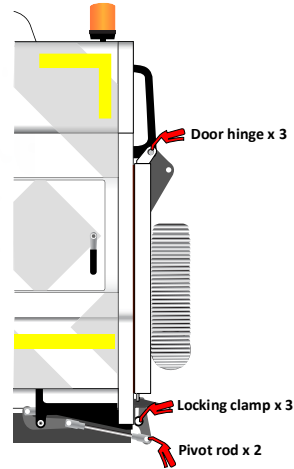

Hopper body and rear door

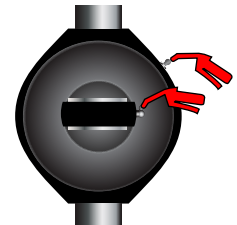

Hopper ram  
(viewed from below)

## LCD monitor - Options screen





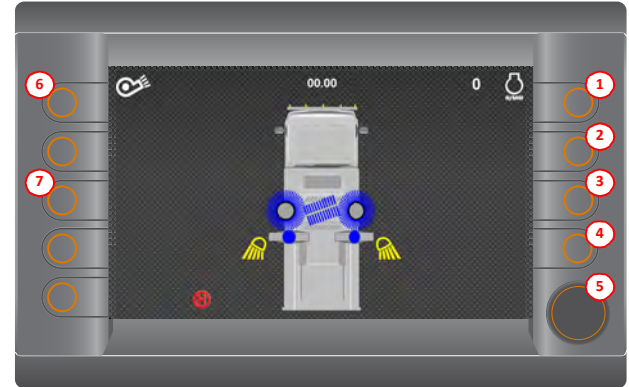

To Access the option screen mode from the start-up screen press button ②

### Button function

1. **Display:** Press to change background colours (black/white).
2. **Menu:** Press to access option screen mode (illustrated).
3. **Hours:** Press to view hours logged.
4. **Return:** Press to return to previous screen.
5. **Encoder:** Turn to highlight required option, press to enter. Used in all screen modes. Press to display side tabs from the sweeping mode screen.
6. **Camera:** Press to enable in forward drive. (rear view only)
7. **Hopper raise/lower and rear door open/close warning buzzer:** Press to disable.



### Screen menu description

-  Driver's fault codes
-  EDC
-  Screen settings
-  Information
-  Button check
-  CAN menu (Password protected)



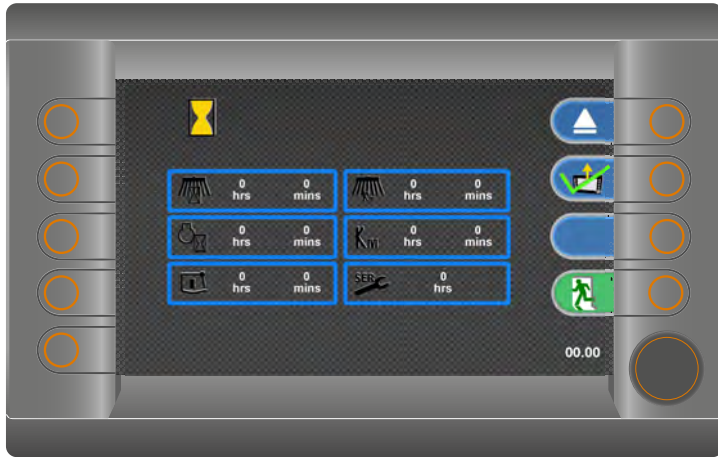

### Hours worked

Displays the working time of various functions.  
Service Hours only display when activated.



### Driver fault codes

Rotate the encoder to highlight either the CAN or desired Node.  
Press the encoder to enter.

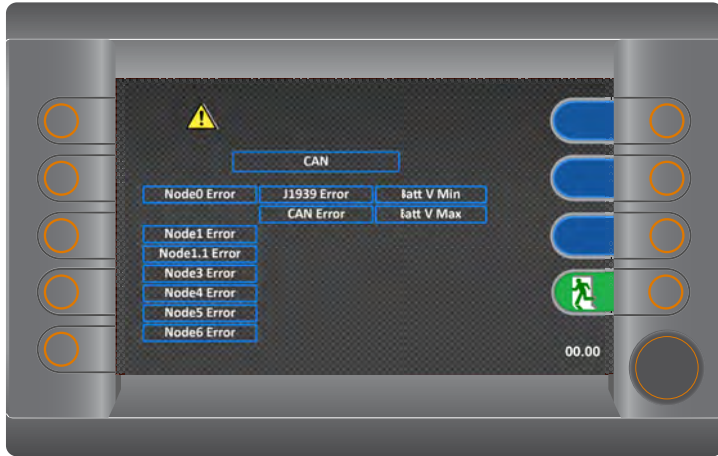

### CAN error screen

Identifies location of system errors.  
Highlighted in red when active.

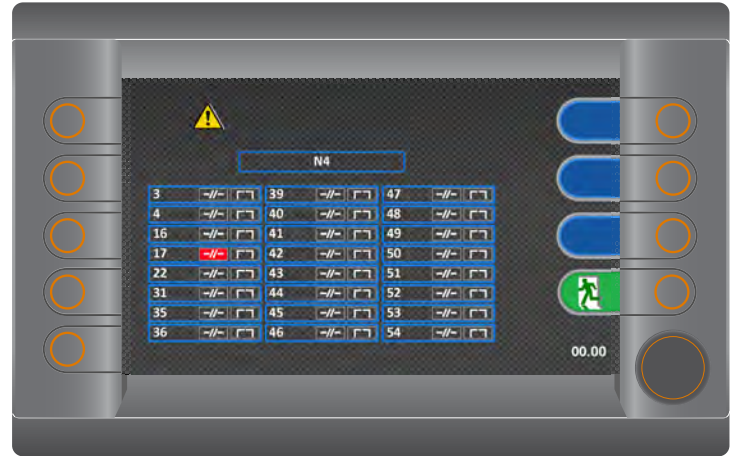

### Driver fault codes

Entering a Node screen allows Pin-Contact view.  
Pin numbers with an active fault are highlighted in RED.

-/- = Open Circuit  
□ □ = Short

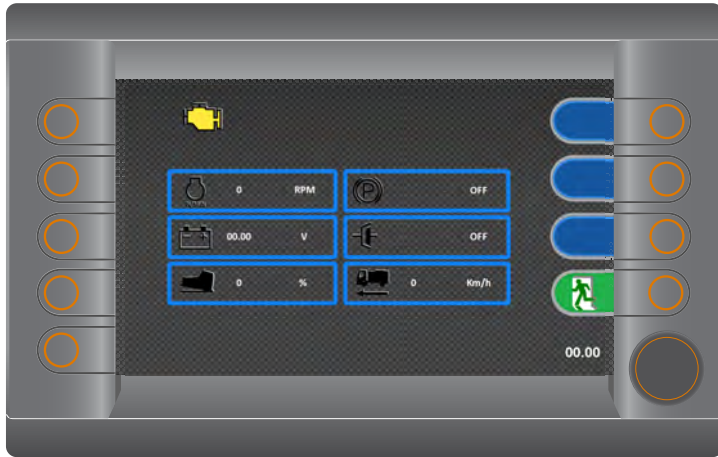

### EDC

Displays the following current conditions:

- **Engine Speed**
- **Battery Voltage**
- **Pedal Position**
- **Parking Brake Position**
- **Clutch Position**
- **Road Speed**



### Screen Settings

Rotate the encoder to highlight the desired panel and press the encoder to enter the setting screen.

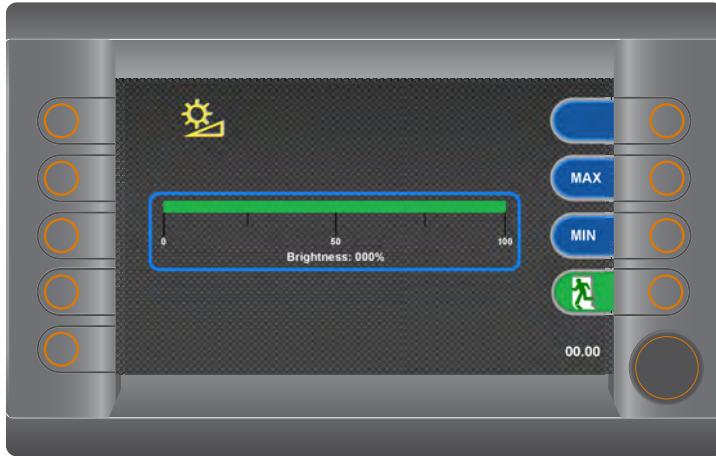

### Screen brightness setting

Rotate the encoder to adjust the screen brightness (2% increments). Pressing the MIN button adjusts the brightness to 10%. Pressing the MAX button adjusts the brightness to 100%.

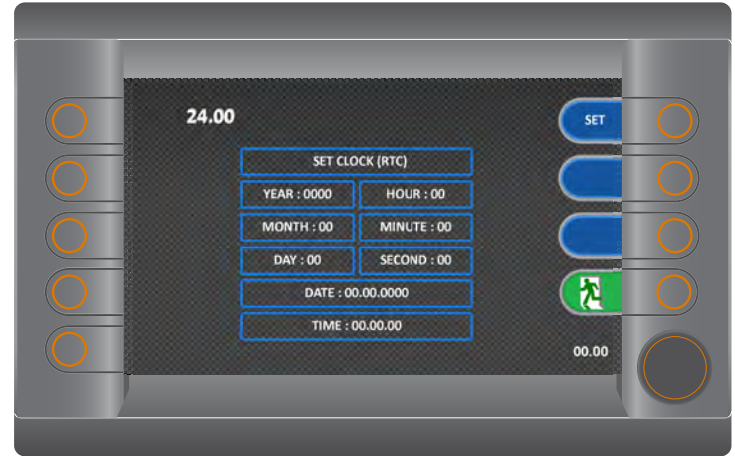

### Time/date setting

Rotate the encoder to the desired panel and press. Rotate to the correct, Year, Day, Hour, etc and press the set button. Repeat above step as required.





### Rear camera

Enable/disable rear camera. When fitted.

A green tick displays in the centre of screen icon when camera is activated.

**NOTE:-** This function allows rear viewing when the vehicle is in forward drive. When reversing the rear view screen activates automatically.

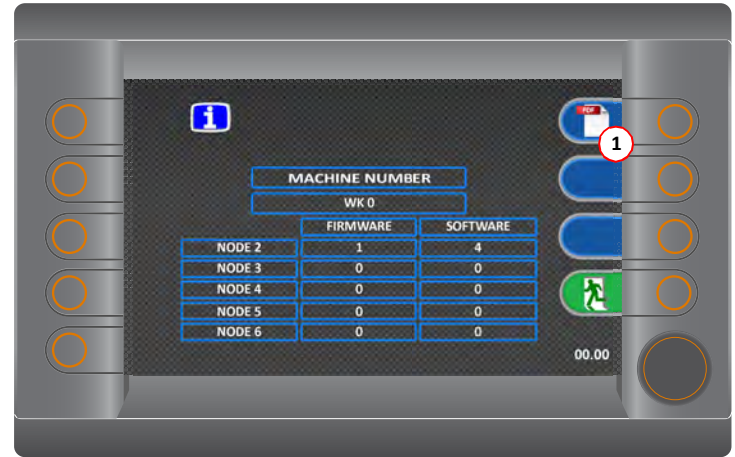

### Information

Displays current Node program version.

Press button ① to access the PDF viewing screen. Follow the on screen directions.

**⚠ Only to be used when vehicle is stationary.**

**NOTE:-** On exiting the PDF viewer ignition must be cycled.

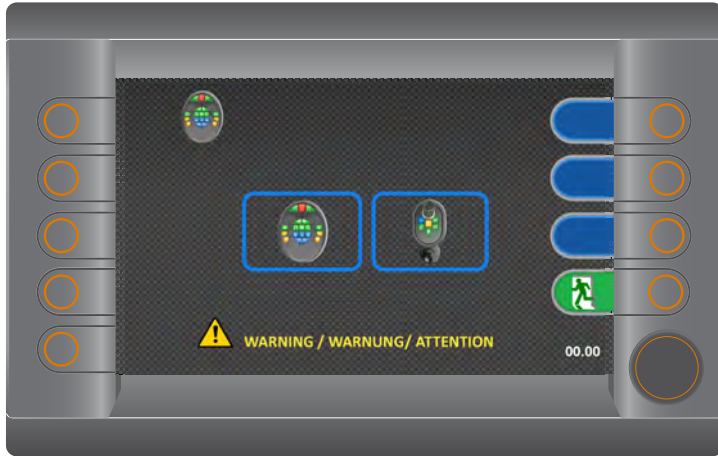

### Button checks

Highlight the appropriate panel and press the controller.



### Main control panel button check

Press the appropriate button on the main control panel.  
As each button is pressed the corresponding graphic will illuminate.  
A beep will sound if the function is fitted.

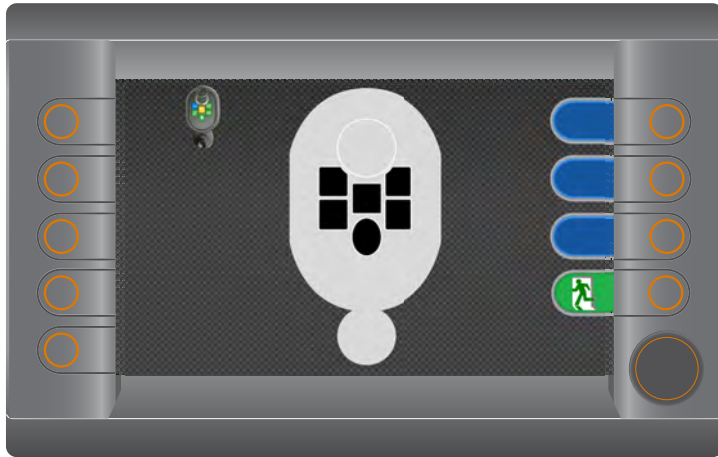

**Auxiliary control panel button check**

Use the main control panel instructions to test buttons and joystick.





## Operator's notes

Operating Instructions

Merlin and Magnum Hydrostatic





## Operator's notes

Operating Instructions

Merlin and Magnum Hydrostatic



**Scarab Sweepers Limited**  
**Pattenden Lane, Marden, Kent TN12 9QD**

Telephone: 01622 831006  
International: +44 (0)1622 831006  
e-mail: [scarab@scarab-sweepers.com](mailto:scarab@scarab-sweepers.com)

Fax: 01622 832417  
International: +44 (0)1622 832417  
Web site: [www.scarab-sweepers.com](http://www.scarab-sweepers.com)