

MAXI-COMPACT SWEEPERS

The industry reference in maxi-compact sweepers. Expertly engineered to deliver exceptional performance.



RAVO R5 & R5e

HIGH PERFORMANCE 5m³ COMPACT ROAD SWEEPERS



WELCOME TO **RAVO**

High performance road sweeping & cleaning solutions

With a long and pioneering history in the industry, RAVO is a leading manufacturer of high-quality compact road sweeping solutions spanning from 1 to 5 cubic metre hopper capacities. RAVO sweepers are durable and reliable sweepers engineered with operator efficiency, comfort and safety in mind.

Partnered with a strong global dealer network and an expert Parts & Service team, RAVO is proud to offer our customers a complete range of products and services.



The leader in Maxi-Compact sweepers

The **R5** and the **R5e** set the standard for performance, quality and durability. Our RAVO **diesel** and **electric** sweepers are trusted by customers around the world for this reason.

Our machines are powerful, and so
are our partnerships

To find your local RAVO
dealer, visit our website:
ravo.fayat.com



RAVO R5

Robust, reliable and ready to work

With over 12,000 units sold to date, the RAVO R5 is known throughout the industry for its durable construction quality, long service life, and ease of operation.

- **Industry-best compaction rate.** Make the most of the R5's impressive payload with exceptional compaction and large hopper capacity.
- **Automatic ride height/self-leveling system.** Maintain constant self leveled brush pressure for the best sweeping results and reduced brush wear.
- **Robust, maintenance-friendly brush system.** The trusted RAVO brush system design is maintenance-friendly and has no greasing points.
- **72 km/h transit speed.** Travel between job sites quickly and easily thanks to the fast transit speed option (up to 72km/h).
- **Best-in-class turning circle.** Sweep the tightest corners and dead end streets thanks to the R5's exceptional manoeuvrability.



R5

SIZE: 11.4 tonnes GVW

SWEEP SPEED: 0 - 15 km/h

HOPPER CAPACITY: 5.0 m³

WATER TANK: 600 litres

FUEL TANK: 120 litres

TYPICAL PAYLOAD: 4650 - 5260 kg

SWEEP WIDTH:

- > 2200 - 2400 mm (Standard)
- > Up to 3300 mm (with Third Brush)

ENGINE: IVECO Euro 6 E 4.5 L Diesel 4 Cylinder

Leave nothing behind

The R5 achieves best-in-class performance by offering customers:

- A powerful fan, constructed from a wear resistant steel alloy to deliver exceptional suction.
- Unrivaled debris compaction rate.
- Short stainless steel suction tube to deliver debris directly to the hopper.
- Highest payload capacity in its class.
- Stainless steel hopper as standard.

Trusted reliability

The RAVO R5 has a reputation for reliability thanks to its design, which simplifies maintenance and maximises uptime. The innovative features that make it so easy to maintain also result in a longer service life for the vehicle and lower operating costs; these components include:

- A simple and effective fan cleaning system.
- Large service hatches for easy access to the hopper.
- Only 15 centrally combined greasing points.
- Time saving, easy to change brushes.
- Extremely robust CORTEN steel chassis, guaranteed for 5 years against corrosion.





R5 TECHNICAL SPECIFICATIONS

Suction System

Suction Nozzle Dimensions (L x W)	112 x 630 mm
Suction Nozzle Material	Corten Steel (Optional: Wear Resistant Coating)
Suction Tube Diameter	225 mm
Suction Tube Material	Stainless Steel (Optional: Wear Resistant Coating)

Brush System

Type	Pulled Brush System
Operation	Hydraulic with Joystick
Available Brush Diameter	750 mm (Optional: 900 mm)
Brush Rotation Rate	0 - 210 rpm

Brakes & Electrical System

Front Axle Brakes	Disc Brakes
Rear Axle Brakes	Drum Brakes
Front Suspension	Independent Hydropneumatic
Rear Suspension	Rubber Cone Springs
Battery	2 x 12/72 V/Ah

Maintenance

Hopper Material	Stainless Steel (Interior) / ABS Plastic Cladding (Exterior)
Number of Lubrication Points	15
Warranty	2 Years or 2000 Engine Hours (Whichever is reached first)

Wellbeing

Noise LPA (Inside Cabin)	74 dB
Noise LWA (Outside Cabin)	110 dB (99 dB optional)

* Depending on local legislation

Standard vs. Container Dump

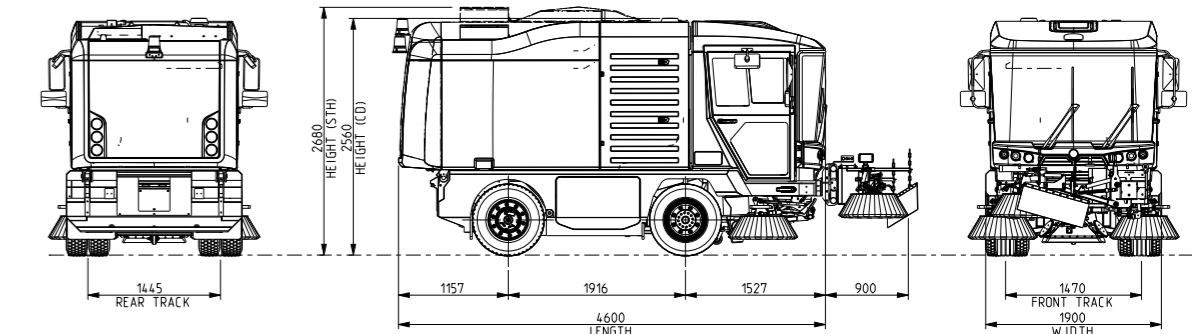

Standard (STH)

Container Dump (CD)

Volume	5 m ³	4 m ³
Length	4625 mm	4625 mm
Height	2700 mm	2510 mm
Dumping Height	850 mm	860 - 1550 mm
Width (inc. Mirrors)	2280 mm	2280 mm
Wheelbase	1916 mm	1916 mm
Brushing Width	2200 - 3300 mm (with Third Brush)	2200 - 2400 mm (with Third Brush)
Climbing Ability	Up to 30% Gradient	Up to 30% Gradient
Vehicle Weight	11400 kg	11400 kg
Min. Total Kerb Weight	6070 kg	6280 kg
Max. Load Capacity	5330 kg	5120 kg

Engine

Engine & Drive	Euro 6 E
Capacity	4.5 L
Max. Torque	580 @ 1250 - 1940 rpm
Max. Power	118 kW (160 hp) @ 2500 rpm
Type	Iveco Diesel 4 Cylinder
Transit Speed*	0 - 72 km/h
Drive	Hydrostatic

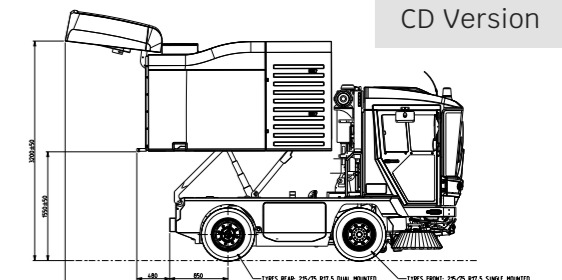

CD Version

RAVO R5e

Reliable electric RAVO technology - the first and still the best

The R5e combines all of the benefits of the R5 with innovative electric technology, offering customers the performance they expect plus:



Low Noise



Optimized Energy Usage



Battery Management



Fast Charge Capability

With powerful all-electric performance and exceptional manoeuvrability, the R5e is the ideal sweeping solution in a range of urban environments.

- **Optimized electric performance.** The R5e's Battery Management System optimises the level of kW/h consumption to offer full shift autonomy.
- **The preferred choice.** RAVO's Lithium Iron Phosphate battery has been specifically chosen to offer our customers safe sweeper maintenance and the longest lifecycle on the market.
- **Warranty that's got you covered.** Have the peace of mind that the warranty of your R5e battery is 3000 cycles or 5 years.



R5e

BATTERY: Flash Lithium Iron Phosphate (LiFePO4)

BATTERY CAPACITY: 100 kWh / 480 v

SWEEP SPEED: 0 - 15 km/h

HOPPER CAPACITY: 5 m³

WATER TANK: 600 litres

SWEEP WIDTH:

- > 2200 - 2400 mm (Standard)
- > Up to 3300 mm (with Third Brush)

CHARGING OPTIONS:

- > Type 2 (IEC 62196-2) offers a maximum rate of 22 kW/h. With this charging method, a full charge takes approx 4.5 hours.
- > A With a CCS Combo 2 (IEC 62196-3) connection, the battery is charged at 70 kW/h via an external charger that fully recharges the battery in approx. 2 hours.

100% performance, 0% emissions

The fully electric R5e doesn't rely on an internal combustion engine for driving or and sweeping meaning that customers achieve the performance they expect from their RAVO sweeper, without emitting CO² or Nitrogen Oxides into the environment.

Quiet

At an industry-low 93 dB outside the cabin, the R5e makes early-morning and late-night shifts viable. Inside the cabin, exceptional soundproofing technology means low noise levels for operators, with maximum levels of no more than 61 dB.

Regenerative braking system

The R5e generates its own energy. When the accelerator is released, the electric motor works like an alternator – the energy that is generated is used to recharge battery. The regenerative braking system allows optimal efficiency of the sweeper, maximizes its autonomy and reduces its operating cost.

Reduced downtime, more cost savings

The R5e doesn't have an engine to service and relies on less hydraulic parts and hoses than a diesel version, resulting in maintenance cost savings of up to 70%.





R5e TECHNICAL SPECIFICATIONS

Suction System

Suction Nozzle Dimensions (L x W)	112 x 630 mm
Suction Nozzle Material	Corten Steel (Optional: Wear Resistant Coating)
Suction Tube Diameter	225mm
Suction Tube Material	Stainless Steel (Optional: Wear Resistant Coating)

Brush System

Type	Maintenance Free RAVO System
Operation	Hydraulic with Joystick
Available Brush Diameter	900 mm (Optional: 700 mm)
Brush Rotation Rate	0 - 210 rpm

Brakes

Front Axle Brakes	Disc Brakes
Rear Axle Brakes	Drum Brakes
Front Suspension	Electrically Regenerative
Rear Suspension	Independent Hydropneumatic
	Rubber Cone Springs

Maintenance

Hopper Material	Stainless Steel (Interior) / ABS Plastic Cladding (Exterior)
Number of Lubrication Points	15
Battery Warranty***	5 Years or 3000 Cycles
Warranty***	2 Years or 2000 Cycles

Wellbeing

Noise LPA (Inside Cabin)	61 dB (Inside Cabin)
Noise LWA (Outside Cabin)	93 dB (Outside Cabin)



Electric Motor & Drive System

Battery Capacity	100 kWh / 480 volt
Battery Type	Lithium Iron Phosphate (LiFePO4)
Max. Torque / Power	765 (Nm) / 150 kW (peak) - 70 kW (nominal)
Chargers (Included with Machine)	22 kW AC Internal
Powertrain	Electric Three-Phase Permanent Magnet Motor
Performance*	Completes a Full Shift
Transit Speed**	0 - 42 km/h

Standard vs. Container Dump

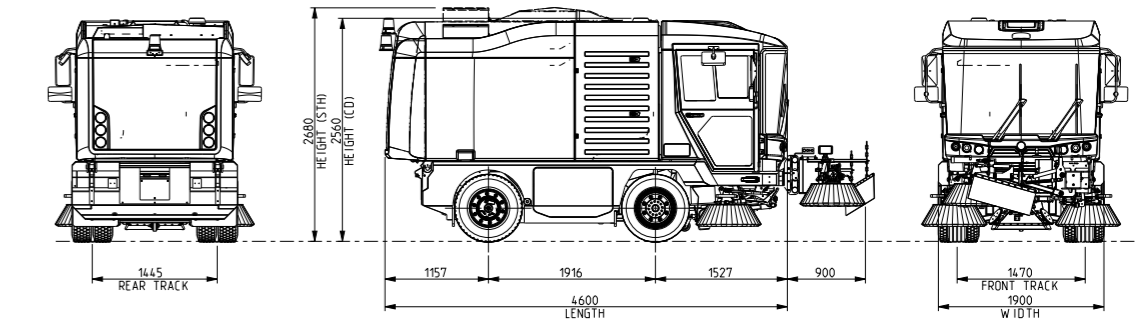

	Standard	Container Dump (CD)
Volume	5 m ³	4 m ³
Length	4625 mm	4625 mm
Height	2705 mm	2560 mm
Dumping Height	850 mm	860 - 1550 mm
Width (inc. Mirrors)	2280 mm	2280 mm
Wheelbase	1916 mm	1916 mm
Brushing Width	2200 - 2400 mm	2200 - 2400 mm
Vehicle Weight	11400 kg	11400 kg
Min. Total Kerb Weight	6500 kg	6710 kg
Max. Load Capacity	4900 kg	4690 kg

* Depending on user profile and use of opportunity charging.

** Depending on local legislation.

*** Whichever is reached first.

OPERATOR FIRST

Performance, visibility and safety for all applications

At RAVO, our focus is on the operators behind the wheel of our sweepers – that's why our machines offer a comfortable cabin, unwavering safety standards and intuitive operation.

The slightly tilted panoramic windscreen of the R5 and R5e provides excellent visibility for the operator to carry out their work safely – and with a low cabin entry height of just 85cm, the machine is easily accessible.

Each of the sweepers in our range delivers reliable performance and high levels of responsiveness that RAVO operators can count on every time they step in the cabin.



Next Generation Telematics.

All RAVO sweepers are equipped with an onboard telematics system that collects 50 signals from the CANbus system, as well as collecting location data and delivering updates on sweeper route information.

As part of the telematics system, the operator has access to data from your Propulse dashboard, or your own fleet management system, via an API connection.

OPTIONS

Tailor your RAVO to meet the demands of your sweeping tasks

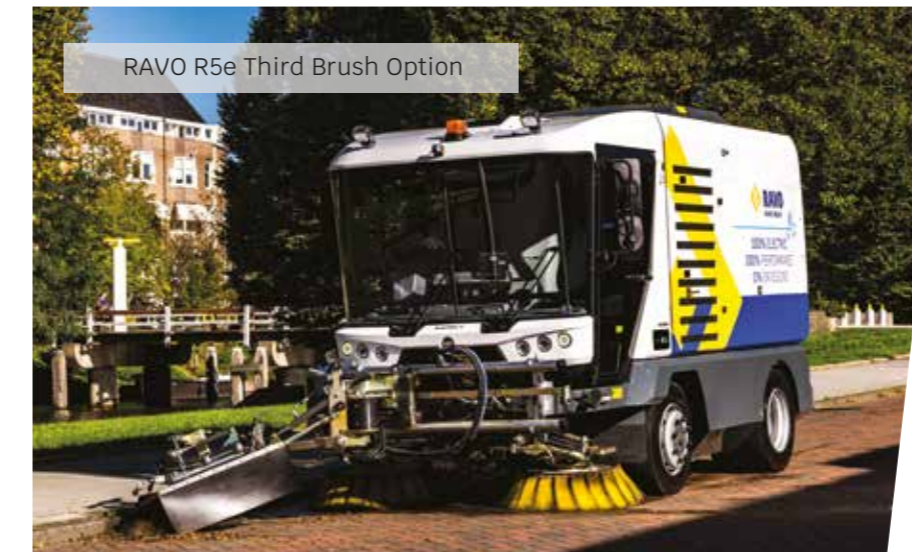

CONTAINER DUMP

> A hopper variant that allows the collected debris to be deposited directly into a container. The dumping height is 1550m.

THIRD BRUSH

> Increase reach and remove weeds without the need to use chemicals with the Third Brush option – adding extra versatility to the already agile RAVO sweeper.

SHUTTER SUCTION TUBE

> The hydraulically operated shutter suction tube opens or closes automatically when the fan is switched on or off to avoid excess debris and water falling to the ground.

WANDERHOSE

> Ideal for sucking up leaves, emptying gulleys and collecting debris from bins.

HEAVY DUTY PACKAGE

> For sweeping heavy materials (sand, grit, etc.), the Heavy Duty Package offers a coated suction system to preserve and protect your sweeper from abrasion.

WATER RECYCLING

> Water is circulated from the hopper to the suction nozzle, and back, meaning that fresh water is only needed for the nozzles near the brushes. This efficiently preserves water and suppresses dust in the hopper.

SWASHER

> The Swasher options adds a front spray bar, high pressure water gun and/or a boom to the top of the hopper for in-depth cleaning.

HIGH PRESSURE WATER PUMP

> Quickly clean the inside of the hopper, the brushes, the suction system or any piece of street furniture with the spray lance.

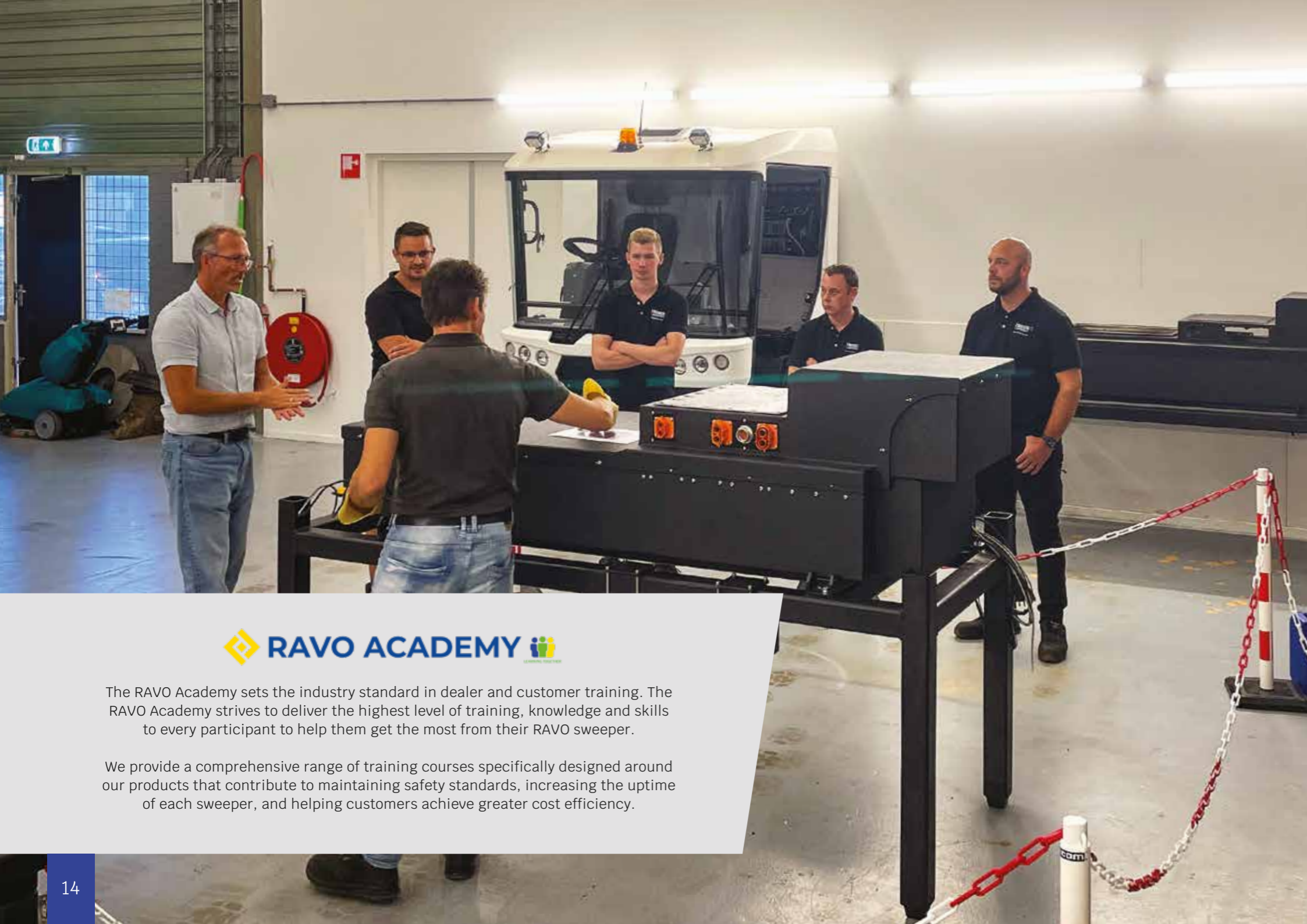

The RAVO Academy sets the industry standard in dealer and customer training. The RAVO Academy strives to deliver the highest level of training, knowledge and skills to every participant to help them get the most from their RAVO sweeper.

We provide a comprehensive range of training courses specifically designed around our products that contribute to maintaining safety standards, increasing the uptime of each sweeper, and helping customers achieve greater cost efficiency.

AFTER SALES SUPPORT

Genuine RAVO parts

The best way to ensure your machine remains working in top condition is by always using Genuine RAVO parts. With a high first time pick rate and dedicated parts facilities stationed around Europe, we'll have your parts to you as quickly as possible, wherever you are in the world.



Class-leading service and Dealer Network

RAVO understands that keeping your machine on the road is one of our most important jobs. That's why we prioritise a Dealer Network that's as powerful as our machines. Find your local dealer for more information about the service options available to you: ravo.fayat.com



myRAVO is a state-of-the-art online portal to help our dealers and customers keep every RAVO machine operating in peak condition. Features include:

- Access to the latest information on all RAVO machines.
- Technical documentation for all models.
- Access to warranty services.
- Marketing and sales support information.

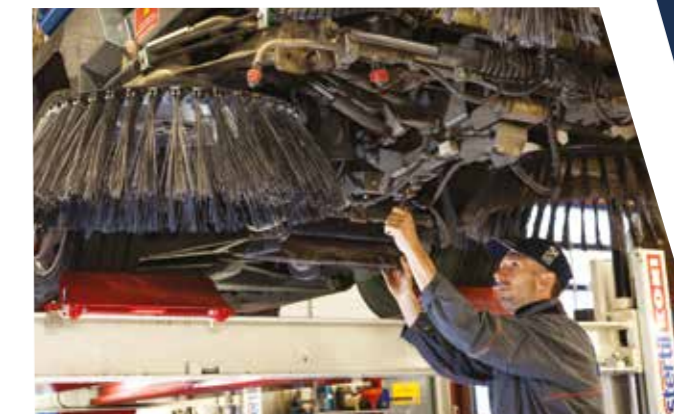

Every effort has been made to ensure that the information in this brochure is correct. RAVO B.V. is not responsible for printing errors or administrative errors.

The industry-standard for maxi-compact sweepers:

- Unrivaled compaction rate.
- Exceptional suction performance.
- Maintenance-friendly, highly durable brush system.
- Electric and diesel, trusted by customers worldwide.

Discover the full RAVO range: ravo.fayat.com



Dealer

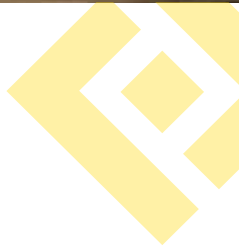

CARING FOR A CLEAN FUTURE