



MERLIN 62

Designed for mounting on a truck chassis in the 10 - 16 tonne GVW range, the Merlin 62 is capable of delivering an unrivalled payload in its class.



POWERFUL & VERSATILE
COMPETENT IN ALL APPLICATIONS

MERLIN 62

REDUCED FUEL
CONSUMPTION

REDUCED
MAINTENANCE

DECREASED
NOISE AND
ENGINE
POLLUTION

Powerful, versatile, and available on a range of chassis weights – the Merlin 62 is competent in every application.

The Merlin 62 is equally at home in municipal and contractor environments. Designed for mounting on a truck chassis in the 10 - 16 tonne GVW range, the Merlin 62 is capable of delivering an unrivalled payload in its class.

Our innovative single-engine hydrostatic system combines with our intuitive CANbus control system to offer users unrivalled control of their sweeper operation – the sweeper allows the operator to control a constant sweeping speed from zero up to 20mph whilst the chassis engine runs at an optimal 1200rpm. This solution allows the Merlin 62 to deliver low fuel consumption and low emissions whilst still supplying powerful and reliable suction performance.



POWERFUL & VERSATILE COMPETENT IN ALL APPLICATIONS

LESS WEIGHT



**Powerful and versatile,
capable in every setting:**

SIZE:	10 - 16 tonne GVW
SWEeper SPEED:	0 - 20mph/0 - 32kph
HOPPER CAPACITY:	6.2 cubic metres
WATER TANK:	1250 - 1800 litres
ENGINE:	Single engine hydrostatic
TYPICAL PAYLOAD:	5500 - 8500kg
SWEEP WIDTH:	2075mm single/3200mm dual

Standard specification

- Stainless steel hopper
- Scarab CANbus control panel incorporating operational information, data logging and self diagnosis
- 1250 - 1800 litre corrosion resistant water tank



Shot blasting the stainless steel hopper

STRONG, ROBUST HOPPER

The hopper is completely manufactured from strong, corrosion and abrasion-resistant 4003 stainless steel, which is shot blasted before a two-pack epoxy primer is applied followed by a hard-wearing topcoat.

Particulate screening, via a hinged stainless steel mesh filter, swings down for ease of cleaning and provides access to the stainless steel inlet cone.





CNG Alternative

The single-engine Merlin 62 mounted onto a CNG chassis satisfies the need to have a street cleansing machine that operates solely on alternative fuel, whilst also giving the benefits of reduced fuel costs combined with lower servicing and chassis maintenance costs. The Merlin 62 CNG constitutes an economic, up-to-date and dependable alternative to diesel vehicles, improving both acoustic and gaseous emissions simultaneously.

The hybridisation of Scarab's single-engine design and CNG power arguably creates the cleanest combustion engine truck mount sweeper available on the road today.



EXTENSIVE SWEEPING PERFORMANCE

The Merlin 62 is available in both single and optional dual sweep configuration. When the suction nozzle, side brush and widesweep functions are in operation the Merlin 62 can sweep up to 2365mm width. However, the brushes can reach an impressive 3200mm span when simultaneously dual sweeping.

With variable brush speeds, optional down pressure and swivelling widesweep, the Merlin 62 is proficient in any sweeping application.

POWERFUL & RELIABLE SUCTION PERFORMANCE

A stainless steel centrifugal roof mounted impeller is positioned to produce an efficient airflow path for high suction performance and reduced power consumption. The fan chamber is easily accessed for cleaning.

Particulate screening, via a hinged stainless steel mesh filter, is pleated to give maximum surface area and reduce blocking – it also swings down for ease of cleaning.

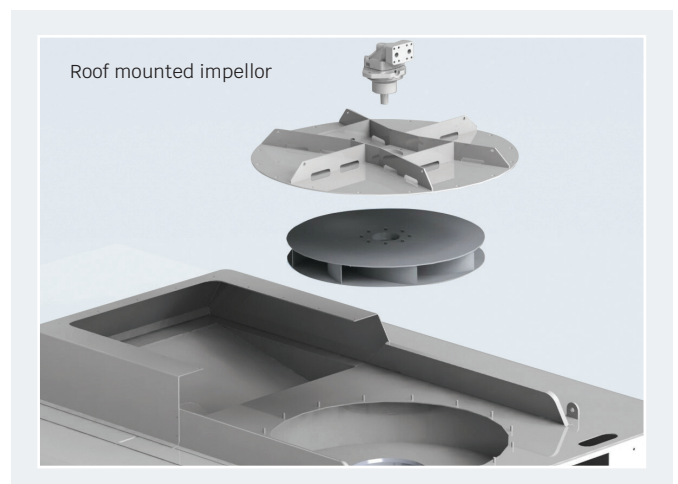

POWER & CONTROL

SINGLE ENGINE, SINGLE EMISSION, NO COMPROMISE

Scarab is the pioneer of the environmentally friendly single-engine truck-mounted sweeper and continues to lead the market in this field. As a result of the single engine system, the Merlin 62 benefits from reduced fuel consumption, decreased noise and engine pollution, less weight, greater payload and reduced maintenance.



CANBUS CONTROL SYSTEM

Scarab's CANbus control system revolutionised the way sweepers are operated and maintained. It continues to evolve today to offer market leading sweeper control.

Our latest CANbus control system offers colour coded door-pod and pedestal controls with key sweeping functions visible at a glance, and comfortably within reach. The large graphical display clearly indicates sweeping configuration and provides the user with regular updates on the vehicle, including warnings and service reminders. What's more, with real-time data-logging built into the system, you can monitor your performance and keep your sweeper functioning at its very best. Scarab's CANbus includes universal connectors for fitment of Global Positioning System (GPS) and the option of real-time data availability via telematics.

“Scarab are at the cutting edge of developing innovative solutions to be more efficient with dust collection, reducing noise pollution and lowering carbon footprints”.



Hydrostatic System

The Scarab designed hydrostatic gearbox is installed in the chassis driveline and allows the sweeping components to be powered directly from the chassis engine. As well bringing a range of benefits such as reduced weight, increased payload, reduced fuel consumption and lower emissions, it also offers a range of operator benefits with its simple joystick control for forward and reverse, allowing single-pedal control which reduces fatigue and enables the driver to fully concentrate on sweeping.

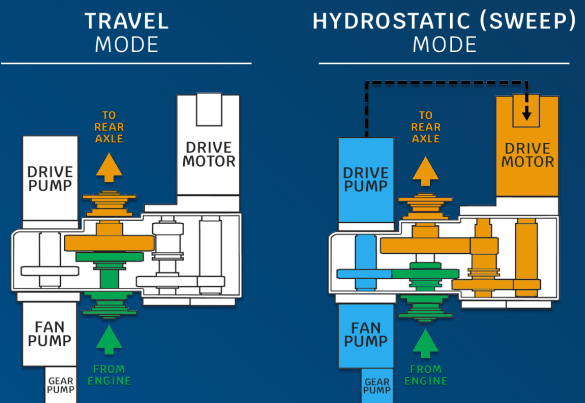

AFTER SALES SUPPORT

Our dedicated After Sales team are Scarab Sweepers' front-line ambassadors and it's their aim to provide you with the highest level of support for the lifetime of your vehicle, delivered through:

- **Industry renowned after sales care.**
- **A range of extended warranty options.**
- **A choice of 'Service', or 'Repair and Maintenance' solutions to suit your needs.**

STANDARD FEATURES

SWEEPING WIDTHS (based on a typical 15 tonne GVW chassis)

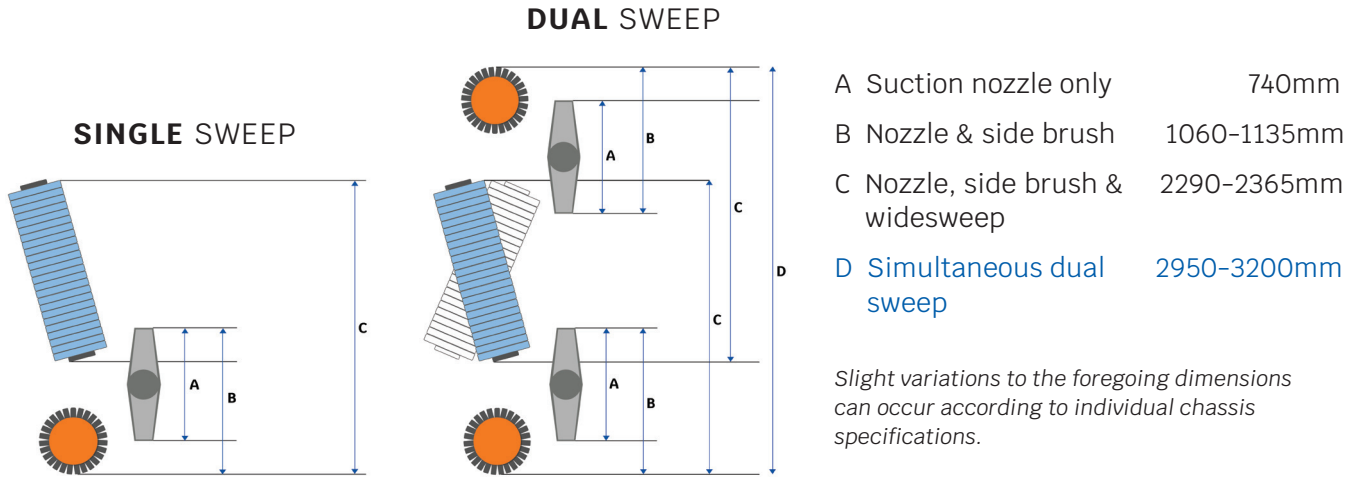

WEIGHTS AND DIMENSIONS

PAYLOAD

Typical Payload Potential 5500 - 8500kg

TYPICAL DIMENSIONAL DATA

Length overall	5640 - 6000mm
Wheelbase	3300mm
Width overall	2220mm
Overall height	hopper lowered 2970mm hopper raised 4500mm

CAPACITIES

Hopper*	Gross volume 6.2m ³ Net/Payload volume 5.5m ³
Water tank**	1250 - 1800 litres

* Calculated in accordance with European Standard EN15429

** Subject to chassis selected

MADE IN BRITAIN, TRUSTED WORLDWIDE



UPGRADES/ENHANCEMENTS

OPTIONS (other options and operator specific requirements are available upon request)



*Some options listed are chassis dependent

WATER

- High-pressure/high volume pump with hand lance and self-retracting hose reel.
- Overhead mounted high-pressure water boom.
- Additional dust suppression for suction nozzles (a 4-jet water-boost bar in front of the nozzle).
- Additional dust suppression for suction tubes (four additional jets at the top of the suction tube).
- Larger water tanks.
- Detergent injection kit for use with the hand lance on difficult cleaning operations.

- Hydrant standpipe, key and 3 metres of 50 mm lay-flat hose for on-task replenishment of water.
- Simultaneous wash and sweep facility.

BRUSHES

- Dual sweep (a second channel brush on opposite side of the sweeper + swivelling widesweep).
- Simultaneous dual sweep (both channel brushes and widesweep operate together).
- Auxiliary channel brush fitted ahead of standard brush on an extending/swing-out mount.
- Adjustable pressure control for channel brushes and widesweep.

- Door-mounted swing-out Wanderhose.
- Door-mounted swing-out wander boom.
- Overhead-mounted wander boom.

MISCELLANEOUS

- CCTV camera to offside brush and/or rear of vehicle.
- Centralised lubrication system (either manual or automatic).
- Alternative or additional beacons.
- Fire extinguisher.



The Merlin 62 is just one of Scarab's expertly engineered truck-mounted road sweeping solutions. Because of its flexibility, the Merlin 62 can be fitted to a wide choice of chassis including those from DAF, Iveco, MAN, Mercedes, Volvo, Renault, Hino and more. For details on suitable chassis specifications, please contact your local distributor.

MERLIN 62

www.scarab-sweepers.com

Dealership

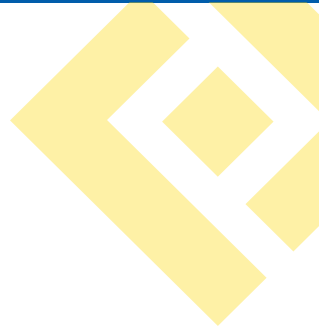

SCARAB SWEEPERS LTD

Pattenden Lane, Marden,
Tonbridge, Kent,
United Kingdom TN12 9QD

TEL +44 (0)1622 831006
www.scarab-sweepers.com