



# MAGNUM 72

Class leading performance in the 15 - 18 tonne GVW range, the Magnum 72 is capable of delivering powerful cleansing results in municipal, construction and road maintenance settings.



**BIG ON CAPACITY**  
**BIG ON PERFORMANCE**

# MAGNUM 72

REDUCED FUEL CONSUMPTION

GREATER PAYLOAD

REDUCED MAINTENANCE

DECREASED NOISE AND ENGINE POLLUTION

Big on capacity, big on performance - heavy-duty road sweeping from 15 - 18 tonne GVW.

The Magnum 72 has been designed for mounting on a truck chassis in the range of 15 - 18 tonne GVW and is capable of delivering powerful cleansing results in municipal, construction and road maintenance settings.

With a 7.2 cubic metre hopper providing a potential payload capacity of up to 9000kg and water capacity ranging from 1800 - 2500 litres, the Magnum 72 is the optimum road sweeper for any operator looking to work harder, for longer.

For the most demanding of heavy-duty applications, Scarab's optional high-speed fan solution takes the Magnum 72's performance to the next level.



## BIG ON CAPACITY BIG ON PERFORMANCE

LESS  
WEIGHT



### Big on capacity, big on performance:

SIZE:	15 - 18 tonne GVW
SWEEPING SPEED:	0 - 20mph/0 - 32kph
HOPPER CAPACITY:	7.2 cubic metres
WATER TANK:	1800 - 2500 litres
ENGINE:	Single engine hydrostatic
TYPICAL PAYLOAD:	6000 - 9000kg
SWEEP WIDTH:	2365mm single/3200mm dual

### Standard specification

- Stainless steel hopper
- Scarab CANbus control panel incorporating operational information, data logging and self diagnosis
- 1800-2500 litre corrosion resistant water tank



### STRONG, ROBUST HOPPER

The hopper is completely manufactured from strong, corrosion and abrasion-resistant 4003 stainless steel, which is shot blasted before a two-pack epoxy primer is applied followed by a hard-wearing topcoat.

Particulate screening, via a hinged stainless steel mesh filter, swings down for ease of cleaning and provides access to the stainless steel inlet cone.



Shot blasting the stainless steel hopper



- 
- Trailed widesweep brush is adjustment-free and designed to ensure parallel usage.
  - Trailed, robust, steel suction nozzle for durability.
  - Adjustable dust-suppression jets.
  - Short suction hoses are an easy and low-cost replacement and are simple to clean.
  - Trailed channel brush mechanism with adjustable brush-pressure control option.
  - Simultaneous dual sweep and high-pressure street wash option.



### EXTENSIVE SWEEPING CAPABILITIES

The Magnum 72 is available in both single and optional dual sweep configuration. When the suction nozzle, side brush and widesweep functions are in operation the Magnum 72 can sweep at 2365mm width. However, the brushes can reach an impressive 3200mm span when simultaneously dual sweeping.

With variable brush speeds, optional down pressure and swiveling widesweep, the Magnum 72 is proficient in any sweeping application.

### POWERFUL & RELIABLE SUCTION PERFORMANCE

A stainless steel centrifugal roof mounted impeller is positioned to produce an efficient airflow path for high suction performance and reduced power consumption. The fan chamber is easily accessed for cleaning.

For customers looking to deliver exceptional results across a range of heavy-duty applications, Scarab's optional high-speed fan solution is capable of taking the Magnum 72's performance to the next level.

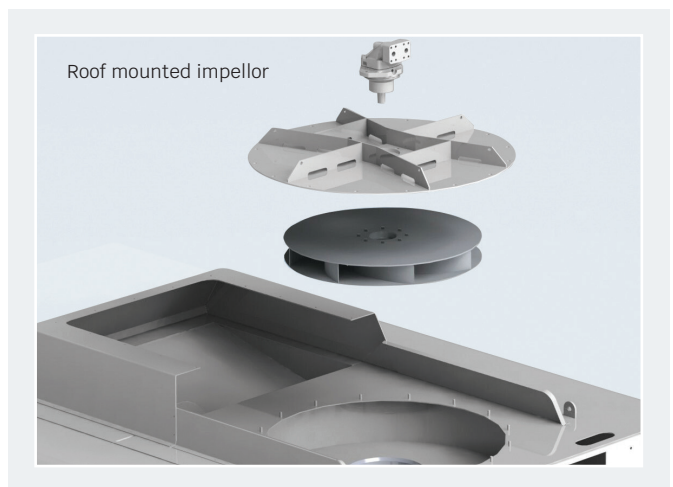

# POWER & CONTROL

## SINGLE ENGINE, SINGLE EMISSION, NO COMPROMISE

Scarab is the pioneer of the environmentally friendly single-engine truck-mounted sweeper and continues to lead the market in this field. As a result of the single engine system, the Magnum 72 benefits from reduced fuel consumption, decreased noise and engine pollution, less weight, greater payload and reduced maintenance.



## CANBUS CONTROL SYSTEM

Scarab's CANbus control system revolutionised the way sweepers are operated and maintained. It continues to evolve today to offer market leading sweeper control.

Our latest CANbus control system offers colour coded door-pod and pedestal controls with key sweeping functions visible at a glance, and comfortably within reach. The large graphical display clearly indicates sweeping configuration and provides the user with regular updates on the vehicle, including warnings and service reminders. What's more, with real-time data-logging built into the system, you can monitor your performance and keep your sweeper functioning at its very best. Scarab's CANbus includes universal connectors for fitment of Global Positioning System (GPS) and the option of real-time data availability via telematics.

“Scarab are at the cutting edge of developing innovative solutions to be more efficient with dust collection, reducing noise pollution and lowering carbon footprints”.



## Hydrostatic System

The Scarab designed hydrostatic gearbox is installed in the chassis driveline and allows the sweeping components to be powered directly from the chassis engine. As well bringing a range of benefits such as reduced weight, increased payload, reduced fuel consumption and lower emissions, it also offers a range of operator benefits with its simple joystick control for forward and reverse, allowing single-pedal control which reduces fatigue and enables the driver to fully concentrate on sweeping.

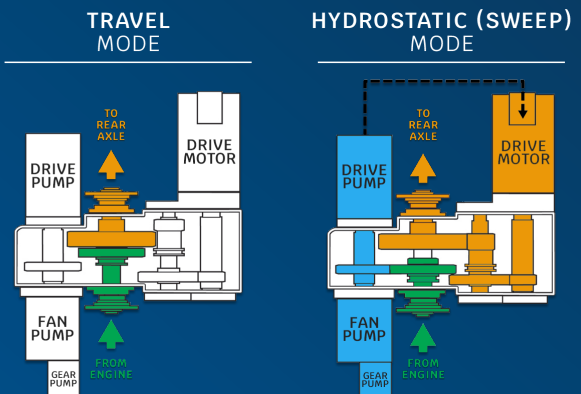

## AFTER SALES SUPPORT

Our dedicated After Sales team are Scarab Sweepers' front-line ambassadors and it's their aim to provide you with the highest level of support for the lifetime of your vehicle, delivered through:

- **Industry renowned after sales care.**
- **A range of extended warranty options.**
- **A choice of 'Service', or 'Repair and Maintenance' solutions to suit your needs.**

# STANDARD FEATURES

## SWEEPING WIDTHS (based on a typical 15 tonne GVW chassis)

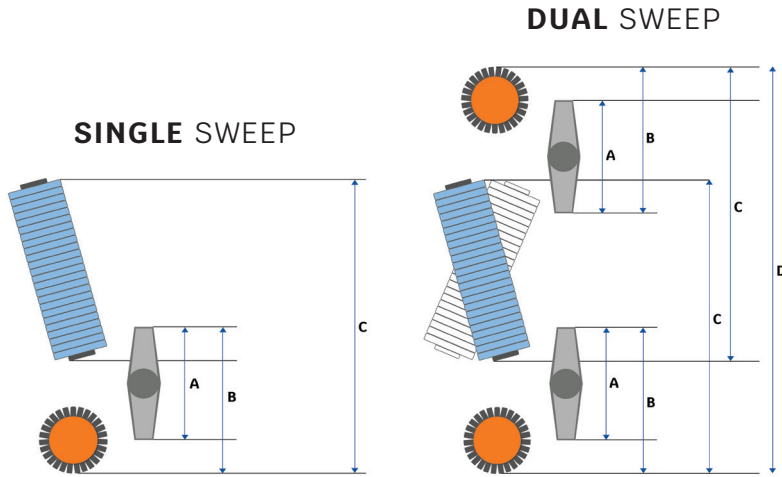

A Suction nozzle only	740mm
B Nozzle & side brush	1135mm
C Nozzle, Side brush & widesweep	2365mm
D Simultaneous dual sweep	3200mm

*Slight variations to the foregoing dimensions can occur according to individual chassis specifications.*

## WEIGHTS AND DIMENSIONS

### TYPICAL PAYLOAD POTENTIAL

**Typical Payload Potential** 6000 - 9000kg

### TYPICAL DIMENSIONAL DATA

<b>Length overall</b>	6100mm
<b>Wheelbase</b>	3620 - 3900mm
<b>Width overall</b>	2400mm
<b>Overall height</b>	
hopper lowered	3250mm
hopper raised	5000mm

### CAPACITIES

<b>Hopper*</b>	Voided volume 7.2m <sup>3</sup> Payload volume 6.5m <sup>3</sup>
<b>Water tank**</b>	1800 - 2500 litres

\* Calculated in accordance with European Standard EN15429

\*\* The option of an additional water tank is available subject to chassis selected

### MADE IN BRITAIN, TRUSTED WORLDWIDE



# UPGRADES/ENHANCEMENTS

## OPTIONS (other options and operator specific requirements are available upon request)\*



\*Some options listed are chassis dependent

### WATER

- High-pressure/high volume pump with hand lance and self-retracting hose reel.
- Overhead mounted high-pressure water boom.
- Additional dust suppression for suction nozzles (A 4-jet water-boost bar in front of the nozzle).
- Additional dust suppression for suction tubes (four additional jets at the top of the suction tube).
- Detergent injection kit for use with the hand lance on difficult cleaning operations.
- Hydrant standpipe, key and 3 metres

of 50 mm lay-flat hose for on-task replenishment of water.

- Simultaneous wash & sweep facility.

### BRUSHES

- Dual sweep (a second channel brush on opposite side of the sweeper + swivelling widesweep).
- Simultaneous dual sweep (both channel brushes and widesweep operate together).
- Auxiliary channel brush fitted ahead of standard brush on an sliding/swing-out mount.
- Adjustable pressure control for channel brushes and widesweep.

- Tilting brush.
- Vari brush (variable in/out brush control).

### SUCTION SYSTEM

- Rear-mounted swing-out wander boom.
- Overhead-mounted wander boom.
- Door-mounted Wanderhose.

### MISCELLANEOUS

- CCTV camera to offside brush and/or rear of vehicle.
- Centralised lubrication system (either manual or automatic).
- Alternative or additional beacons.
- Fire extinguisher.



The Magnum 72 is just one of Scarab's expertly engineered truck-mounted road sweeping solutions. Because of this flexibility, the Magnum 72 can be fitted to a wide choice of chassis including those from DAF, Iveco, MAN, Mercedes, Volvo, Renault, Freightliner and more. For details on suitable chassis specifications, please contact your local distributor.

# MAGNUM 72

[www.scarab-sweepers.com](http://www.scarab-sweepers.com)

Dealership

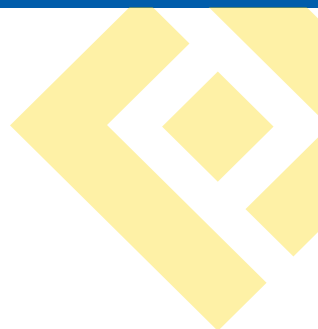

## SCARAB SWEEPERS LTD

Pattenden Lane, Marden,  
Tonbridge, Kent,  
United Kingdom TN12 9QD

TEL +44 (0)1622 831006

[www.scarab-sweepers.com](http://www.scarab-sweepers.com)



**SCARAB**  
FAYAT GROUP

SCARAB ♦ Leave nothing behind