

MAVEN 65

Skid mounted road sweeper

FAYAT



Illustrated Parts Catalogue



SCARAB ♦ Leave nothing behind

Maven 65 Parts Book

Part No. SCAZ047292

Issue: 3.1.01 11th April 2024

Scarab Sweepers Limited
Pattenden Lane - Marden - Kent TN12 9QD, UK
T: +44 (0)1622 831 006
E: scarab@scarab.fayat.com
W: scarab-sweepers.com

Registered in England No. 18923459 - VAT No. GB 374 5002 68
Registered Office: Pattenden Lane, Marden, Tonbridge, Kent TN12 9QD, UK

Copyright 2024 Scarab Sweepers Limited

Important Notice To Users

This manual is published by the Technical Publications Department of Scarab Sweepers Limited and every effort is made to ensure that the information it contains is correct at the time of publication. Due to a policy of continuous development, however, the Company reserves the right to alter the specification and to supply when so altered without reference to illustrations and descriptions in this manual.

Parts depicted or mentioned in this manual may or may not be fitted to your particular road sweeper due to various options that may or may not have been selected and does not therefore infer that the part should be fitted to your particular road sweeper or is missing. If in doubt then please contact the Scarab Parts Department for clarification.

It is imperative that the correct model is FULLY identified when procuring replacement parts for your Scarab Sweeper. To avoid unnecessary confusion and delays caused by incorrectly ordered parts, please refer to the Vehicle Serial Number (CE) Plate and take note of the vehicle's number.



i The Serial Number Plate is located on the left hand side of the subframe, below the engine frame door.

The example shown here is for guidance only.

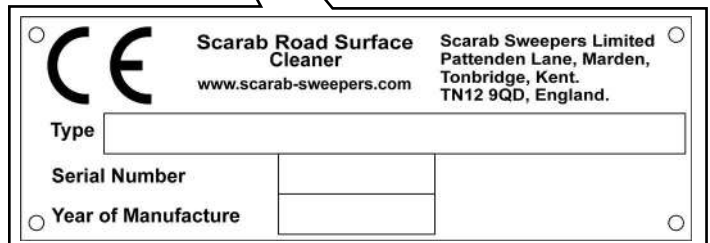

This information **MUST** accompany EVERY parts order to help ensure that the correct parts are supplied.

Introduction

This parts book has been organised to facilitate ease of use when identifying and procuring replacement parts for the Scarab Sweeper.

The information content has been arranged in a logical manner by creating a number of separate sections, each dealing with a specific aspect or sub-system of the machine, complete with its own table of contents. Where relevant, cross-references from one section to another have been included to enable the user to quickly navigate to the information that gives the required level of detail.

 Please note that the illustrations in this book are for identifying parts and is not indicative of assembly order.

Using the Parts Lists

The parts lists in this parts book are accompanied by an illustration. The breakdown structure within each parts list reflects the inter-relationship of the various components in an assembly.

They list the item, its part number, quantity and description and a page number () if this part is cross referenced elsewhere in his manual. See Figure 1.

This parts book covers both 12volt and 24volt systems. Lines in Orange are for 12V systems only and lines in Green are for 24V systems only. Blue and white lines are for both systems. See Figure 1.

Item	Part No	Qty	Description	
①	044491	1	Hopper control valve, 12V, includes items ③, ④ and ⑥	
②	039703	1	Hopper control valve, 24V, includes items ③, ⑤ and ⑥	
③	039746	2	Solenoid valve	
④	041225	4	Coil, 12V / 17.2 WATTS-ELZ	
⑤	039747	4	Coil, 24V with diode	
⑥	039748	2	Coil spacer	
⑦	035242	2	Port plug $\frac{3}{8}$ " BSP	
⑧	011153	6	Dowty seal $\frac{3}{8}$ " BSP	

Figure 1: Example of a parts list

Item Numbers (Item)

Item numbers are used to cross-refer items from the parts lists to their associated illustrations and vice-versa, except for, attaching parts.

If the illustration of an item is superfluous or not illustrated, then the item number will be listed as not illustrated:- NI.

Part Numbers (Part No)

Not every item will have a part number associated with it because it might be an assembly that is broken down into its components elsewhere or there might be different versions of that item described elsewhere.

If a part number is marked as **TBC** then this means **to be confirmed**. Please contact Scarab Part Department.

Quantities (Qty)

When a parts quantity has been marked with **As Req** then this means **as required**, for example hose lengths may differ slightly due to the route taken, or you may have one or more of a given part then the quantity will be **as required** due to the quantity of said part that is fitted to a particular sweeper configuration.

Description

A brief description of the part to further help with identification.

Page ()

Use the number in this column to go to that page to get more information regarding this item/part.

PDF Version

Includes bookmarks to each chapter and links to other sections from components that are also referenced elsewhere to make navigation throughout the manual easier. For example click a number in the Page () column and it will take you to that page, or click an item in the table of contents to be taken to that page.

Warranty Statement

1. Scarab Sweepers Limited (hereinafter referred to as the Company) warrants that (subject to the other provisions of the published Terms and Conditions of Sale - available upon request) upon delivery and for a period of 12 months from the date of actual delivery, or 2,000 running hours from the date of actual delivery whichever is sooner, the Goods correspond with their specification at the time of delivery, and will be free from defects in materials and workmanship.
2. The Company does not warrant the condition or quality of any used Goods supplied to the Customer, or other truck manufacturers' chassis cab content or to the auxiliary engine fitted in the Scarab Sweeper or to any other component not manufactured by the Company and any such warranty claims must be submitted to the manufacturer of that component, or their locally appointed agent.
3. The Company shall not be liable for a breach of any of the warranties in condition 1 unless the Customer gives written notice of the defect to the Company, and (if the defect is as a result of damage in transit) to the carrier, within 7 days of the time when the Customer discovers or ought to have discovered the defect.
4. The Company shall not be liable for a breach of any of the warranties in condition 1 if the Customer makes any further use of such Goods after giving such notice, the defect arises because the Customer failed to follow the Company's oral or written instructions as to the storage, installation, commissioning, use or maintenance of the Goods or (if there are none) good trade practice, or the Customer alters or repairs such Goods without the written consent of the Company, or uses non genuine parts to effect a repair.
5. The following consumable items listed are excluded from the Company warranty:
 - all fuel oils,
 - antifreeze,
 - all brush link pivots and bushes,
 - wander hoses, suction nozzles,
 - body inlet ducts, wearing plates,
 - high pressure water pump piston seals and valves,
 - door seals,
 - inlet seals,
 - batteries,
 - tyres,
 - all brushes,
 - lift cables,
 - rubber skirts,
 - suction nozzle wheels,
 - flap trunking,
 - deflectors,
 - screens flaps or blanking plates,
 - water pump diaphragm valves and water jets,
 - all filter strainers and elements,
 - windows,
 - glass mirrors,
 - light bulbs,
 - fuses,
 - brake lining pads,
 - auxiliary drive belts and any other part normally regarded as consumable.
6. Any parts replaced under the terms of this warranty will be covered by the unexpired portion of this warranty.
7. Subject to conditions 3 and 4, if any of the Goods do not conform with any of the warranties in condition 1 the Company shall at its option repair or replace such Goods (or the defective part) or refund the price of such Goods at the pro rata Contract rate provided that, if the Company so requests, the Customer shall, at the Customer's expense, remove the defective Goods or part of such Goods and return the Goods or the part of such Goods which is defective to the Company. Parts replaced under warranty will be delivered by the Company FOB port of exportation.
8. If the Company complies with the terms contained in this statement it shall have no further liability for a breach of any of the warranties in condition 1 in respect of such Goods.
9. No representative or agent of Scarab Sweepers Limited has the authority to add or to vary these Warranty Conditions except with the Company's official confirmation in writing from Scarab Sweepers Limited, head office in Marden Kent, England.

For further information, please refer to the Company's Terms & Conditions of Sale. In the event of conflict between this Warranty Statement and the Company's Terms & Conditions of Sale the latter will prevail.

Table of Contents

<i>Description</i>	<i>Page</i>
Maven 65 Parts Book	1
Important Notice To Users	4
Introduction	5
Using the Parts Lists	5
Quantities (Qty)	5
Warranty Statement	6
Table of Contents	7
Sweeping	17
Left hand leg and side brush arrangement	19
Left hand leg and central brush mount	20
Left hand dummy leg and central brush mount	21
Left hand leg, side brush king post	22
Left hand leg, side brush deployment mounting bracket	23
Left hand, side brush swing in/out ram arrangement	24
Left hand, side brush, raise/lower, brush link	25
Left hand, side brush raise/lower, top link	26
Left hand, side brush, raise/lower ram	27
Left hand, side brush, swivel plate	28
Left hand, side brush, pressure arrangement	29
Left hand, side brush, leg hose tidy	30
Left hand, side brush skirt	31
Left hand, side brush, swivel plate attach (non titling)	32
Left hand, side brush motor (non tilting)	33
Left hand, side brush, swivel plate attach (tilting)	34
Left hand, side brush tilt (tilting)	35
Left hand, side brush motor (tilting)	36
Left hand, side brush, brush hub: superseded	37
Left hand, side brush, brush hub: revised	38
Left hand, side brush, water jets mounting	39
Right hand leg and side brush arrangement	40
Right hand leg and central brush mount	41
Right hand dummy leg and central brush mount	42
Right hand, side brush king post	43
Right hand, side brush deployment ram mounting bracket	44
Right hand, side brush swing in/out ram arrangement	45
Right hand, side brush, raise/lower, brush link	46
Right hand, side brush, raise/lower, top link	47
Right hand, side brush, raise/lower, ram	48
Right hand, side brush, raise/lower, swivel plate	49
Right hand, side brush pressure	50
Right hand, side brush, hose tidy	51
Right hand, side brush skirt	52
Right hand, side brush, swivel plate attach (non tilting)	53
Right hand, side brush motor (non tilting)	54
Right hand, side brush, swivel plate attach (tilting)	55
Right hand, side brush tilt (tilting)	56
Right hand, side brush motor (tilting)	57
Right hand, side brush hub: superseded	58

Right hand, side brush hub: revised	59
Right hand, side brush, water jets mounting	60
Dual water jets, side brush	61
Brushes, side	62
Central brush (wide sweep) arrangement	63
Central brush (wide sweep) mounting	64
Central brush (wide sweep) support - fixed slew	65
Central brush (wide sweep) support slewing	66
Central brush (wide sweep) slewing ram	68
Central brush (wide sweep) skirt	69
Central brush (wide sweep) LH raise lower ram	70
Central brush (wide sweep) LH shock absorber	71
Central brush (wide sweep) LH drive motor	72
Central brush (wide sweep) LH drive motor plate	73
Central brush (wide sweep) RH raise lower ram	74
Central brush (wide sweep) RH shock absorber	75
Central brush (wide sweep) RH bearing support	76
Central brush (wide sweep) RH bearing mounting plate	77
Central brush (wide sweep), bearing assembly	78
Central brush (wide sweep) bearings and taper shaft	79
Central brush (wide sweep) spherical bearing LH	80
Central brush (wide sweep) spherical bearing RH	81
Central brush (wide sweep) pneumatic pipes and fittings	82
Central brush (wide sweep), brush core	83
Suction	85
Left hand suction nozzle arrangement	87
Left hand suction hose	88
Left hand suction nozzle lift	89
Left hand suction nozzle skirt	90
Left hand suction nozzle frame	91
Left hand suction nozzle tow hitch	92
Left hand suction nozzle pivot	93
Left hand suction nozzle tilt ram	94
Left hand suction nozzle tilt return springs	95
Left hand suction nozzle, flaps and skid plate	96
Left hand suction nozzle, water	97
Right hand suction nozzle arrangement	98
Right hand suction hose	99
Right hand suction nozzle lift	100
Right hand suction nozzle skirt	101
Right hand suction nozzle frame	102
Right hand suction nozzle tow hitch	103
Right hand suction nozzle pivot	104
Right hand suction nozzle tilt ram	105
Right hand suction nozzle tilt return springs	106
Right hand suction nozzle, flaps and skid plate	107
Right hand suction nozzle, water	108
Left hand suction spigot	109
Left hand suction spigot water	110
Left hand suction deflector tube	111
Left hand suction deflector	112
Left hand auto blanking, flap lid and arm	113

Left hand auto blanking, pneumatic cylinder	114
Right hand suction spigot	115
Right hand suction spigot water	116
Right hand suction deflector tube	117
Right hand suction deflector	118
Right hand auto blanking, flap lid and arm	119
Right hand auto blanking, pneumatic cylinder	120
Deflector swing plate	121
Standard wander hose arrangement	122
Standard wander hose	123
Hose attachment, standard wander hose	124
Blanking cap plate, standard wander hose	125
Hose hooks, standard wander hose	126
Wander boom arrangement	127
Wander boom, hose and boom tube	128
Wander boom, hose sleeve	129
Wander boom, hinge mounting bracket	130
Wander boom, swivel hinge	131
Wander boom, lift support	132
Wander boom, hose support	133
Wander boom, stowage bracket	134
Wander boom, tube blanking stowage	135
Overhead boom arrangement	136
Overhead boom, elbow and access cover	137
Overhead boom, elbow and bearing	138
Overhead boom, stop	139
Overhead boom, spring anchor	140
Overhead boom, cuff	141
Overhead boom, spring adjuster	142
Overhead boom, retainer	143
Overhead boom, retrieval hook	144
Overhead boom, hose and coupling	145
Overhead boom, coupling	146
Overhead boom, coupling stowage bracket	147
Overhead boom, boom extension	148
Overhead boom, boom extension hose saver	149
Overhead boom, boom extension tube	150
Overhead boom, boom extension tube stowage brackets	151
Suction fan	153
Suction fan	154
Suction fan motor	156
Suction fan guard	158
Suction fan filter screen	160
Hopper and body	163
Hopper and body arrangement, external	164
Hopper and body arrangement, external	165
Hopper unit	166
Cover lid, hopper	167
Hopper pivot pins and bushes	168
Hopper lift ram mounting	169
Bump stop, hopper safety prop	170

Covers, hopper lockers	171
Locker door, left hand side	172
Locker door, right hand side	173
Hopper access hatch, left hand side	174
Hopper access hatch, right hand side	175
Hopper capping, left hand side	176
Hopper capping, right hand side	177
Hopper LED beacons and rear LED marker lights	178
Hopper lifting eyes, bolts and plugs	179
Hose fixing clips, hopper	180
Cover plate, wander boom hose duct	181
Fan inspection covers, external	182
Fan inspection covers, internal	183
Hopper rear door arrangement	184
Hopper rear door	185
Strainer, tall, rear door	186
Grab handles and cable guides, rear door	187
Warning lights, rear door	188
Warning light, hopper rear right side	189
Warning light, hopper rear left side	190
Rear door strainer outlet, hose version	191
Rear door strainer outlet, valve version	192
Rear door wander hose blanking plate	193
Rear door options brackets	194
Wander hose stowage hooks - Rear door option	195
Direction arrow, when no hose hooks - Rear door option	196
Direction arrow, when hose hooks are used - Rear door option	197
Light Arrow - Rear door option	198
Chapter 8 Reflective chevrons for rear panels	199
Rear door hinge	200
Rear door locking	201
Hopper chute	202
Rear camera	203
Water	205
Schematic - Low pressure water, dual sweep, no additional water	206
Schematic - Low and high pressure water, dual sweep, no additional water	208
Schematic - Low and high pressure water, dual sweep, with additional water	210
Water tank	212
Water tank anti-vibration mounts	213
Water tank mounting support plates	214
Water level sight tube, water tank	215
Lid, water tank	216
Fittings, water tank, front	217
Sump fittings and drain, water tank	218
Sump fittings and drain, water tank with auxiliary water tank	220
Fittings, water tank rear	222
Auxiliary water tank, 650 litre (172 US gallons), mounting location	223
Auxiliary water tank arrangement	224
Auxiliary water tank, lower mounting brackets	225
Auxiliary water tank, upper mounting braces	226
Auxiliary water tank, filler lid	227
Auxiliary water tank, water level sight tube	228

Auxiliary water tank, valve fittings	229
Auxiliary water tank, hydrant filler fittings	230
Water strainer and fittings	231
Water strainer, water tank attachment fittings	232
Low pressure water pump mounting	233
Low pressure water pump fittings	234
Water pump, twin diaphragm, low pressure, components	235
Water valves, low pressure, location	236
Water valves, low pressure, assemblies	237
Water valves, low pressure, components	238
Water spray nozzle, twin, side brushes	239
Water spray nozzles, suction nozzle	240
Water spray nozzles, suction spigot	241
Front spray bar, low pressure	242
Over head boom, dust suppression	243
High pressure water pump, mounting	244
High pressure water pump, motor and fittings	245
High pressure water pump, fittings and hoses	246
High pressure water pump 30lpm, seal and repair kits	247
Water manifold (HP) label plate	248
Water manifold (HP) mounting bracket	249
Water manifold (HP) fittings, valves, and hoses	250
Front spray bar, high pressure	252
Hose reel, high pressure	253
Detergent kit	254
Hand lance, water gun	255
Boost spray bar - Rear of LH suction nozzle	256
Boost spray bar - Rear of RH suction nozzle	257
Boost spray bar - Rear of central brush (wide sweep)	258
Suction fan wash assist	259
Water tank filler arrangement	260
Hydraulics	261
Engine frame hydraulics	262
Hydraulic tank arrangement	262
Hydraulic tank hoses	263
Hydraulic tank hose fittings	264
Hydraulic tank filters and fittings	265
Hydraulic fan pump and gear pumps	266
Hydraulic fan pump hoses	267
Hydraulic fan pump hose fittings	268
Hydraulic gear pump hoses	269
Hydraulic gear pump hose fittings	270
Hydraulic flow control valve hoses	271
Hydraulic flow control valve fittings	272
Hydraulic high pressure oil filters	273
Hydraulic fan and suction nozzle tilt control valve block, coils and solenoids	274
Hydraulic fan and suction nozzle tilt control valve block, hoses and fittings	275
Main and option valve blocks in hydraulic cabinet	276
Main valve block, coils, solenoids, check valves and plugs - 12 volt systems	277
Main valve block, coils, solenoids, check valves and plugs - 24 volt systems	278
Main valve block, fittings	279
Main valve block, pipes and hoses	280

Option valve block, coils, solenoids, check valves and plugs - 12 volt systems	281
Option valve block, coils, solenoids, check valves and plugs - 24 volt systems	282
Option valve block, fittings	283
Option valve block, pipes and hoses	284
Hopper and subframe hydraulics	285
Hopper and rear door control valve	285
Hopper and rear door control valve - hoses	286
Hydraulic hand pump	287
Hopper lift ram	288
Hopper door ram	289
Suction fan motor	290
Steel pipes for suction fan - hopper rear left mounted	292
Steel pipes for hopper rear door ram and suction fan drain - hopper rear right mounted	294
Hopper door locking arrangement	296
Sequence and pilot check valve block, hopper door locking	297
Hopper door locking assembly, middle and left side	298
Hopper door locking assembly, right side	299
Door locking manifolds and pressure relief valve	300
Steel pipes, fittings and hoses for dual sweep brushes	301
Clamps for steel pipes for dual sweep brushes	302
Steel pipes, fittings and hoses for right hand sweep brushes	303
Clamps for steel pipes for right hand sweep brushes	304
Steel pipes, fittings and hoses for left hand sweep brushes	305
Clamps for steel pipes left hand sweep brushes	306
Side brush motor	307
Central brush (wide sweep) motor	308
Low pressure water pump motor	309
High pressure water pump motor	310
Side brush lift ram	311
Suction nozzle tilt ram	312
Pneumatics	313
Pneumatic control block and valves, 12V	314
Pneumatic control block and valves, 24V	316
5/2 HT spring valve body and 15mm HT solenoid valve	318
5/2 HT spring valve body	319
15mm HT solenoid valve,	320
5/2 pilot/pilot HT valve	321
5/3 pilot/pilot HT valve	322
Valve, OR gate	323
Seals and gaskets	324
Breather and relief valves	325
Air purge valve	326
Pressure regulator valve and gauge, central brush (wide sweep)	327
Brush pressure valve, gauge and controls - Typical arrangement in the Cab	328
Pneumatic air regulator and filter	329
Pneumatic cylinder, central brush (wide sweep) raise/lower	330
Pneumatic cylinder, central brush (wide sweep) slew	331
Pneumatic cylinder, side brush swing in/out	332
Pneumatic cylinder, side brush pressure	333
Pneumatic cylinder, suction nozzle raise/lower	334
Pneumatic cylinder, auto blanking	335
Pneumatic cylinder, hopper safety prop, kicker	336

Electrical	337
Cab components	338
Main control panel	338
Auxiliary controller (door pod)	339
Hopper controller remote	340
Display screen, operator, programmed	340
CR2012 cabinet module, node	340
Beacon switch	341
Sounder, main control panel	341
Camera monitor	341
Camera splitter	342
Fuses and relays, cab	342
Pneumatic and Node cabinet	343
Nodes	344
Relays	344
Power connection link	344
Power post	345
Switch, gantry work light	345
Cabinet fuse holder arrangement	346
Cabinet fuses	347
Battery junction box	348
Resistors for hydraulic coils, 12V	349
Light, lamps and cameras	350
LED work light	350
LED marker rear light	350
Beacon	350
LED warning beacon	351
Cameras	351
Wiring looms and cables	352
Switches	352
Sensors	353
Fuses	353
Relays	353
 Engine frame and subframe	 355
Engine Frame	356
Roof panel	356
Hopper extension wing, left hand	357
Hopper extension wing, right hand	358
Front door, left hand	359
Front door, right hand	360
End panels	361
Hydraulic oil tank mounting	362
Node-pneumatics cabinet mounting	363
Fuel tank mounting	364
Fuel tank	365
Combined intercooler/radiator/hydraulic oil cooler blanking	366
Combined intercooler/radiator/hydraulic oil cooler mounting	367
Safety bar	368
Battery junction box and oil filter mounting	369
Fuel filters and fuel pump mounting	370
Hopper raise proximity sensor	371
Exhaust stack mounting	372

Air intake stack mounting	373
Coolant expansion tank mounting	374
Remote mounted flow control valve mounting	375
Rear engine mount	376
Front engine mount	377
ECU cover	378
Hydraulic cabinet	379
Main and options valve blocks mounting	380
Lifting eyes	381
Engine frame and ancillary parts	382
Subframe	383
Engine frame and subframe general arrangement	383
Engine frame to subframe mounting	384
Subframe to chassis mounting general arrangement	385
Subframe to chassis mount, position 1	386
Subframe to chassis mount, position 2	387
Subframe to chassis mount, position 3 and 4	388
Subframe to chassis lateral support	389
Folding ladder and grab handle mounting	390
Folding ladder and grab handle	391
Hopper lift ram subframe mounting	392
Hopper safety prop subframe mounting	393
Floor plate	394
Nozzle lift cylinder mounting bracket	395
Adjustable mud wing mounting brackets	396
Mud wings / mudguards	397
Subframe and cable clip brackets	398
Engine	399
Engine arrangement	400
Engine cradles	401
Engine mounts	402
Cooling fan and water pump	403
Ancillary belt, tensioner, alternator and engine speed sensors	404
Starter motor	405
Rail pressure sensor, charge air pressure and temp sensor	406
Coolant temperature sensor	407
Lube oil pressure sensor	408
Injectors and glow plugs	409
Engine, ECU, EAT, and sump drain	410
Fuel pump and filters	411
Exhaust stack	412
Air intake stack, lower	413
Air intake stack, upper	414
Coolant expansion tank	415
Combined oil/intercooler/radiator cooler	416
Centaflex coupling and fan pump housing plate	417
Service kits	418
Cab	419
General layout of cab items	420
Main control panel and operator screen mountings	421
Main control panel	422

Auxiliary (door pod) control panel and node mountings	423
Auxiliary controller (door pod)	424
Operator screen and camera monitor mounting	425
Main control panel and operator screen mountings	426
Brush pressure valve, gauge and controls	427
Remote hopper controller	428
Other components, cab components	429
Labels and decals	431
Warning labels	432
Information labels	433
Information labels	434
Decals and badges	435
Multi-lingual glossary	437

Sweeping

<i>Description</i>	<i>Page</i>
Left hand leg and side brush arrangement	19
Left hand leg and central brush mount	20
Left hand dummy leg and central brush mount	21
Left hand leg, side brush king post	22
Left hand leg, side brush deployment mounting bracket	23
Left hand, side brush swing in/out ram arrangement	24
Left hand, side brush, raise/lower, brush link	25
Left hand, side brush raise/lower, top link	26
Left hand, side brush, raise/lower ram	27
Left hand, side brush, swivel plate	28
Left hand, side brush, pressure arrangement	29
Left hand, side brush, leg hose tidy	30
Left hand, side brush skirt	31
Left hand, side brush, swivel plate attach (non titling)	32
Left hand, side brush motor (non tilting)	33
Left hand, side brush, swivel plate attach (tilting)	34
Left hand, side brush tilt (tilting)	35
Left hand, side brush motor (tilting)	36
Left hand, side brush, brush hub: superseded	37
Left hand, side brush, brush hub: revised	38
Left hand, side brush, water jets mounting	39
Right hand leg and side brush arrangement	40
Right hand leg and central brush mount	41
Right hand dummy leg and central brush mount	42
Right hand, side brush king post	43
Right hand, side brush deployment ram mounting bracket	44
Right hand, side brush swing in/out ram arrangement	45
Right hand, side brush, raise/lower, brush link	46
Right hand, side brush, raise/lower, top link	47
Right hand, side brush, raise/lower, ram	48
Right hand, side brush, raise/lower, swivel plate	49
Right hand, side brush pressure	50
Right hand, side brush, hose tidy	51
Right hand, side brush skirt	52
Right hand, side brush, swivel plate attach (non tilting)	53
Right hand, side brush motor (non tilting)	54
Right hand, side brush, swivel plate attach (tilting)	55
Right hand, side brush tilt (tilting)	56
Right hand, side brush motor (tilting)	57
Right hand, side brush hub: superseded	58
Right hand, side brush hub: revised	59
Right hand, side brush, water jets mounting	60
Dual water jets, side brush	61
Brushes, side	62
Central brush (wide sweep) arrangement	63
Central brush (wide sweep) mounting	64
Central brush (wide sweep) support - fixed slew	65
Central brush (wide sweep) support slewing	66
Central brush (wide sweep) slewing ram	68
Central brush (wide sweep) skirt	69
Central brush (wide sweep) LH raise lower ram	70
Central brush (wide sweep) LH shock absorber	71

Central brush (wide sweep) LH drive motor	72
Central brush (wide sweep) LH drive motor plate	73
Central brush (wide sweep) RH raise lower ram	74
Central brush (wide sweep) RH shock absorber	75
Central brush (wide sweep) RH bearing support	76
Central brush (wide sweep) RH bearing mounting plate	77
Central brush (wide sweep), bearing assembly	78
Central brush (wide sweep) bearings and taper shaft	79
Central brush (wide sweep) spherical bearing LH	80
Central brush (wide sweep) spherical bearing RH	81
Central brush (wide sweep) pneumatic pipes and fittings	82
Central brush (wide sweep), brush core	83

Left hand leg and side brush arrangement

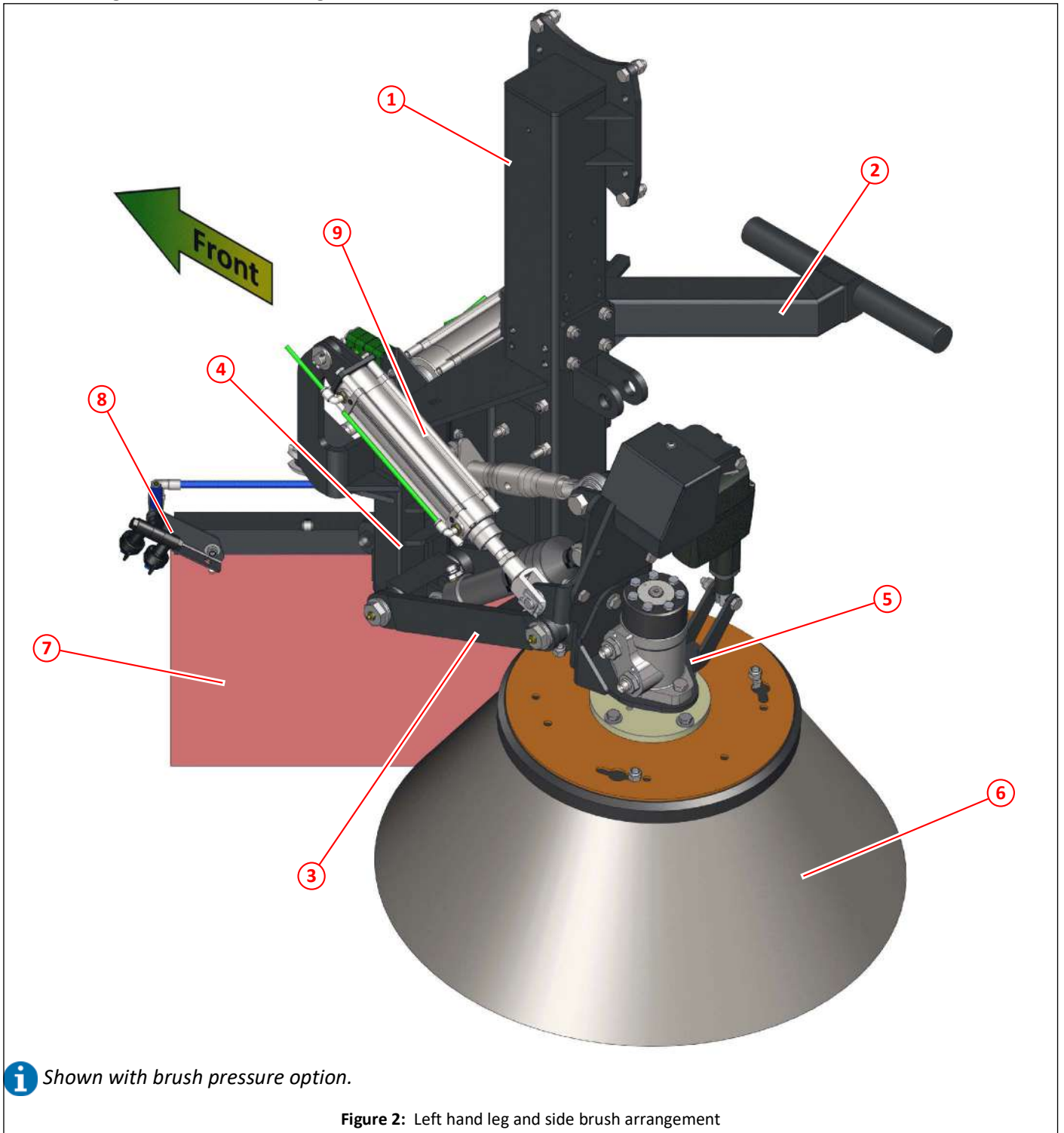

i Shown with brush pressure option.

Figure 2: Left hand leg and side brush arrangement

Item	Part No	Qty	Description	
①	046841	1	Left hand leg	20
②	034334	1	Left hand central brush (wide sweep) adjustable mount	20,21
③			Left hand side brush raise/lower assembly	25,26,27,28
④			Left hand side brush king post, swing in/out arrangement	22
⑤			Side brush motor assembly	33,36
⑥			Side brushes	62
⑦			Front skirt, side brush	31
⑧			Side brush dual water spray	61
⑨			Side brush pressure cylinder (option)	29

Left hand leg and central brush mount

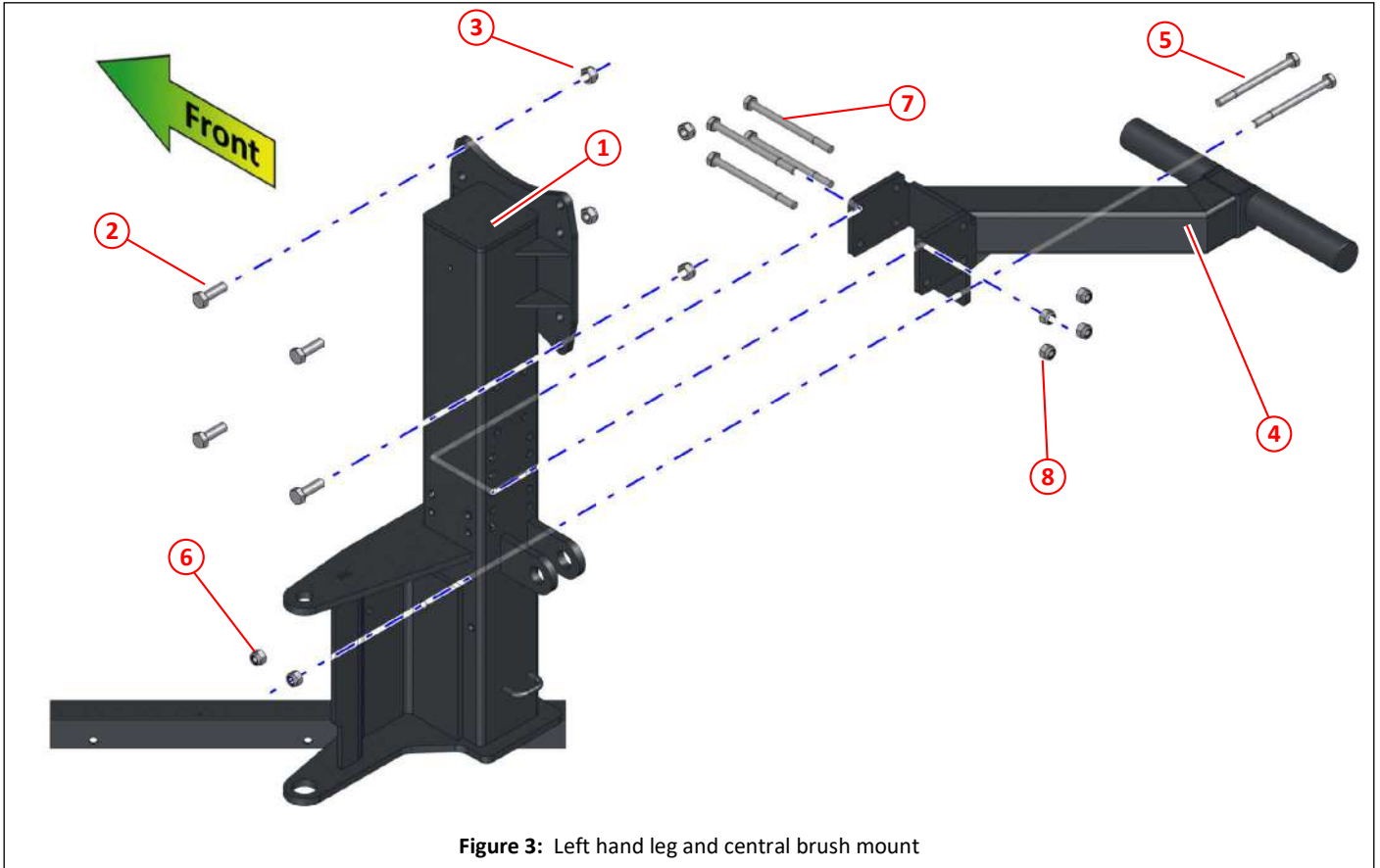

Figure 3: Left hand leg and central brush mount

Item	Part No	Qty	Description
①	046841	1	Left hand leg
②	011053	4	Set screw M12 x 35
③	011077	4	Nyloc nut M12
④	034334	1	Left hand central brush (wide sweep) adjustable mount
⑤	011407	2	Bolt M10 x 120
⑥	011075	2	Nyloc nut M10
⑦	000075	4	Bolt M10 x 130
⑧	011075	4	Nyloc nut M10

Left hand dummy leg and central brush mount

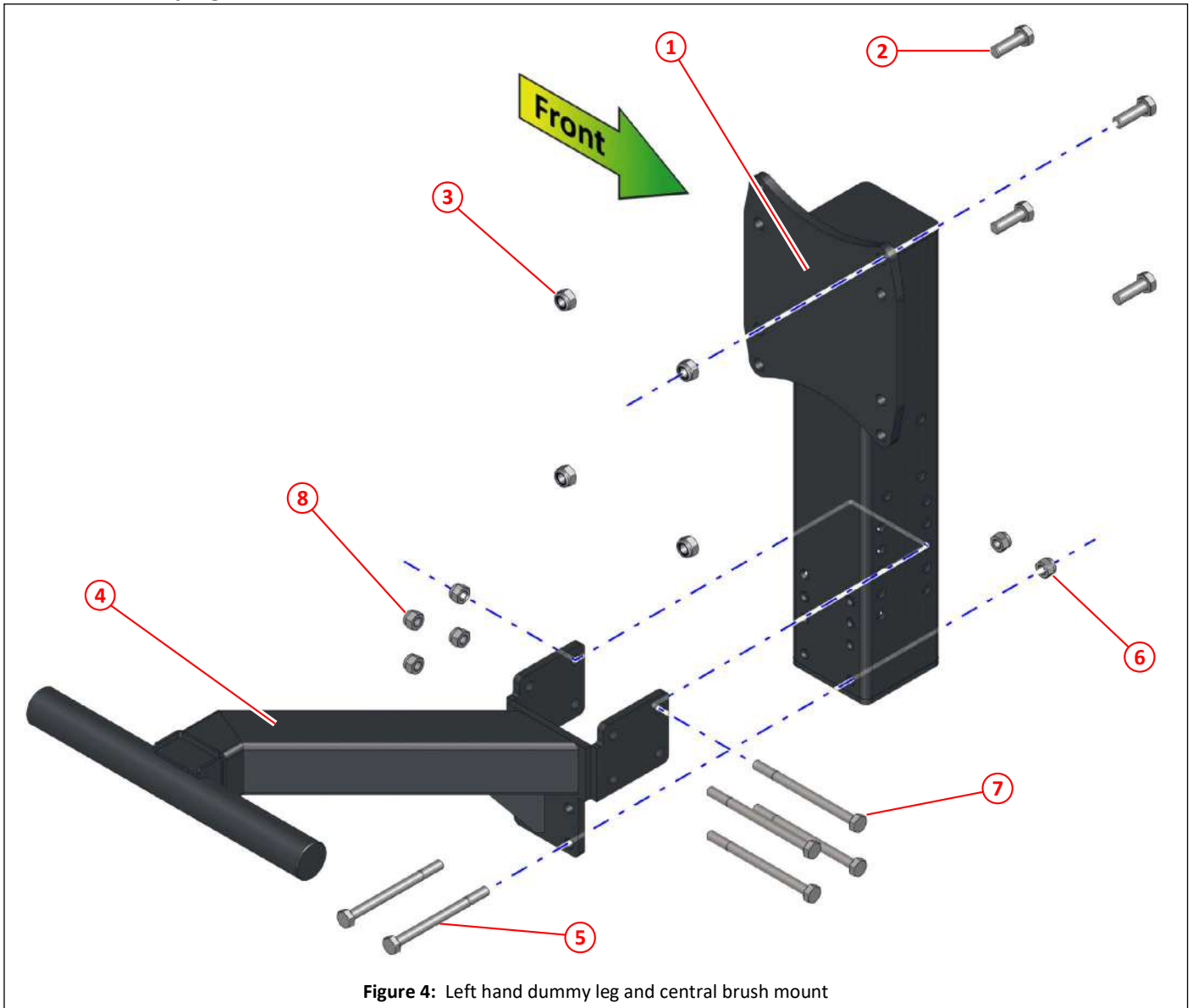

Figure 4: Left hand dummy leg and central brush mount

Item	Part No	Qty	Description
①	042867	1	Dummy leg
②	011053	4	Set screw M12 x 35
③	011077	4	Nyloc nut M12
④	034334	1	Left hand central brush (wide sweep) adjustable mount
⑤	011407	2	Bolt M10 x 120
⑥	011075	2	Nyloc nut M10
⑦	000075	4	Bolt M10 x 130
⑧	011075	4	Nyloc nut M10

Left hand leg, side brush king post

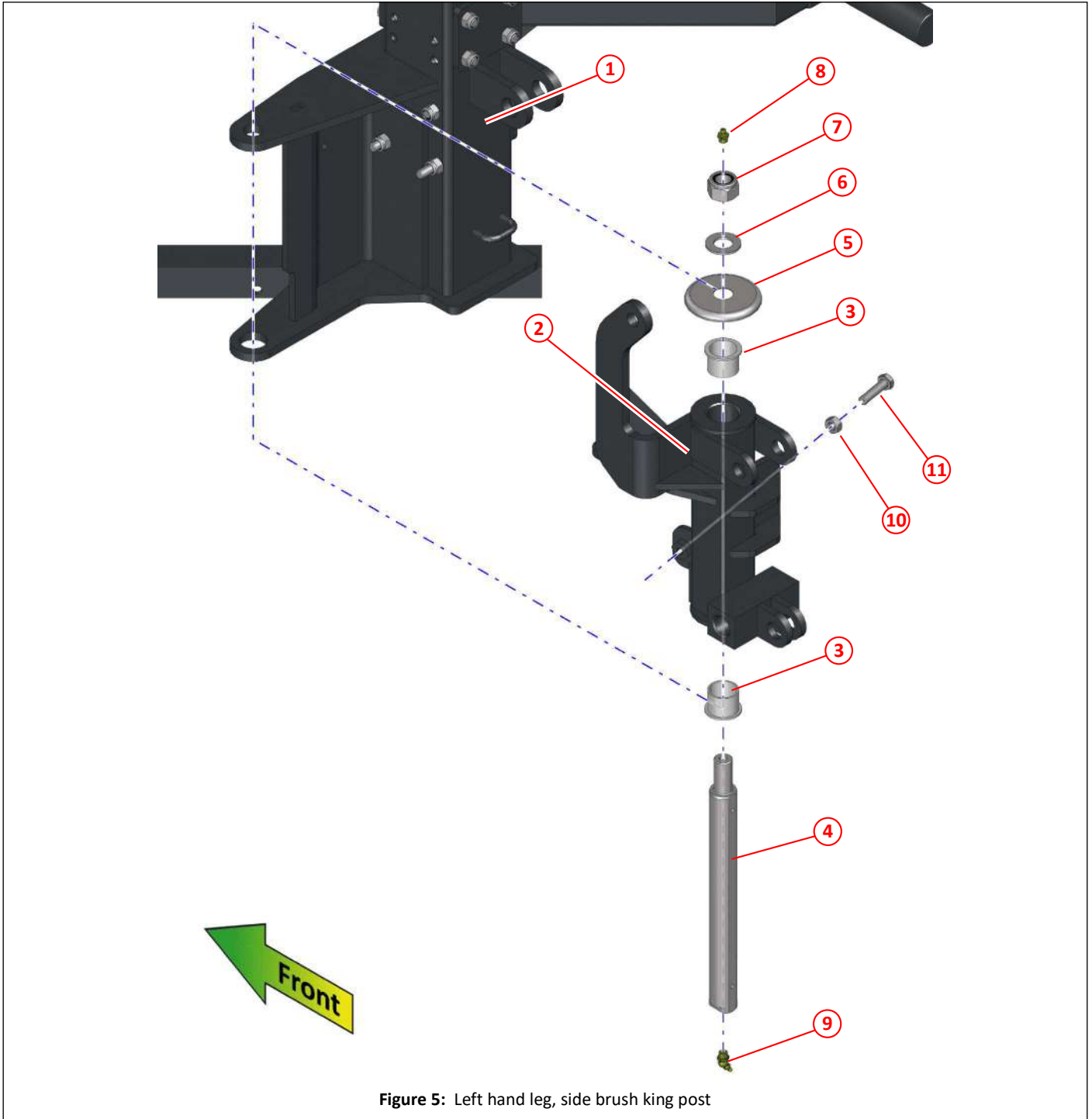

Figure 5: Left hand leg, side brush king post

Item	Part No	Qty	Description
①	046841	1	Left hand leg
②	047024	1	King post, left hand side brush
③	013012	2	Bush, king post
④	013007	1	Kin pin
⑤	013013	1	Dirt shield
⑥	011102	1	Washer M20
⑦	011082	2	Nyloc nut M20
⑧	010903	1	Grease nipple, straight, $\frac{1}{8}$ " BSP
⑨	011060	1	Grease nipple, 135°, $\frac{1}{8}$ " BSP
⑩	011074	1	Full nut M10
⑪	011034	1	Setscrew M10 x 40

Left hand leg, side brush deployment mounting bracket

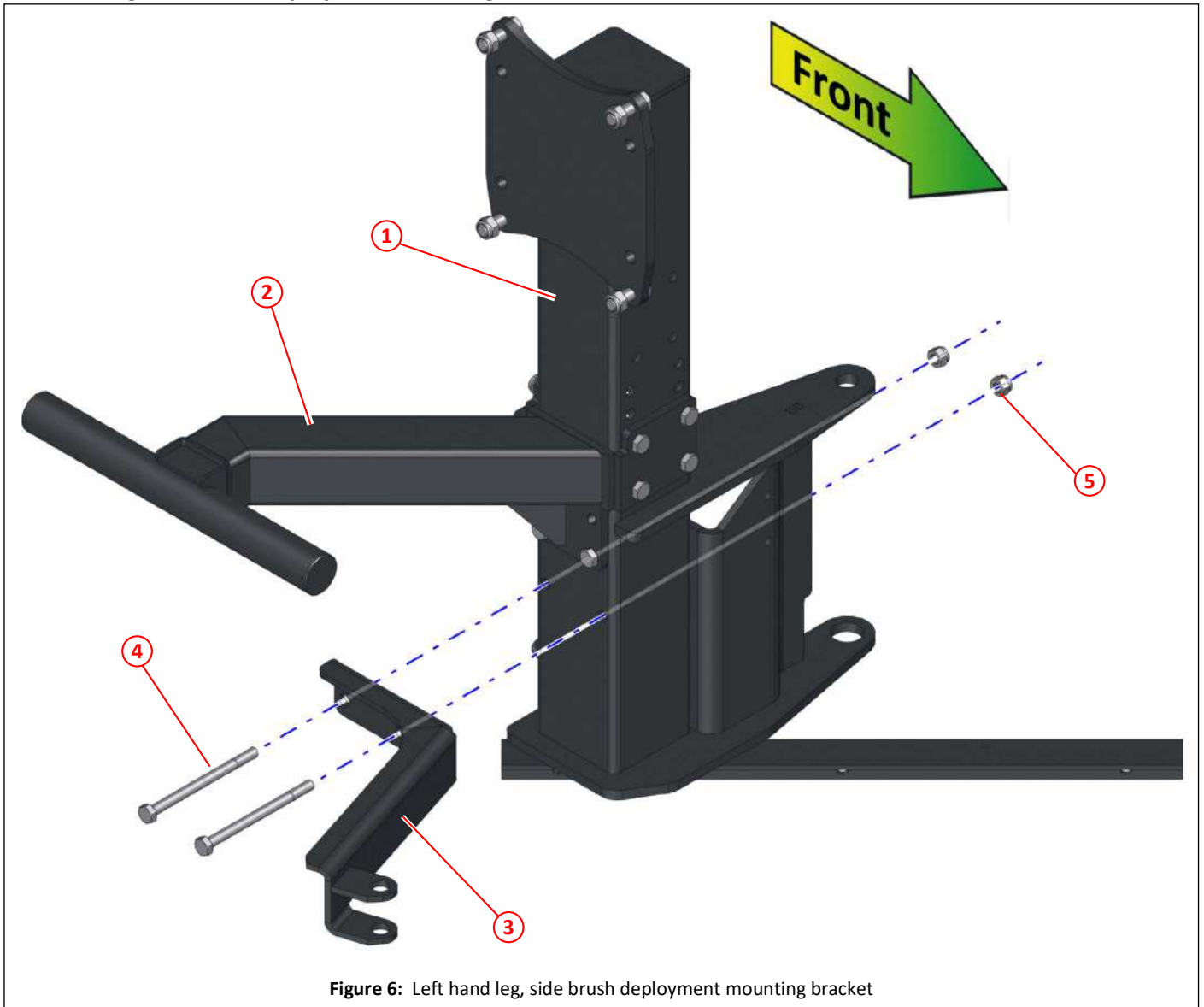

Figure 6: Left hand leg, side brush deployment mounting bracket

Item	Part No	Qty	Description	
①	046841	1	Left hand leg	
②	034334	1	Left hand central brush (wide sweep) adjustable mount	
③	047065	1	Left hand side brush deployment ram mounting bracket	
④	000075	1	Bolt M10 x 130	
⑤	011075	2	Nyloc nut M10	
⑥	011073	3	Nyloc nut M8	

Left hand, side brush swing in/out ram arrangement

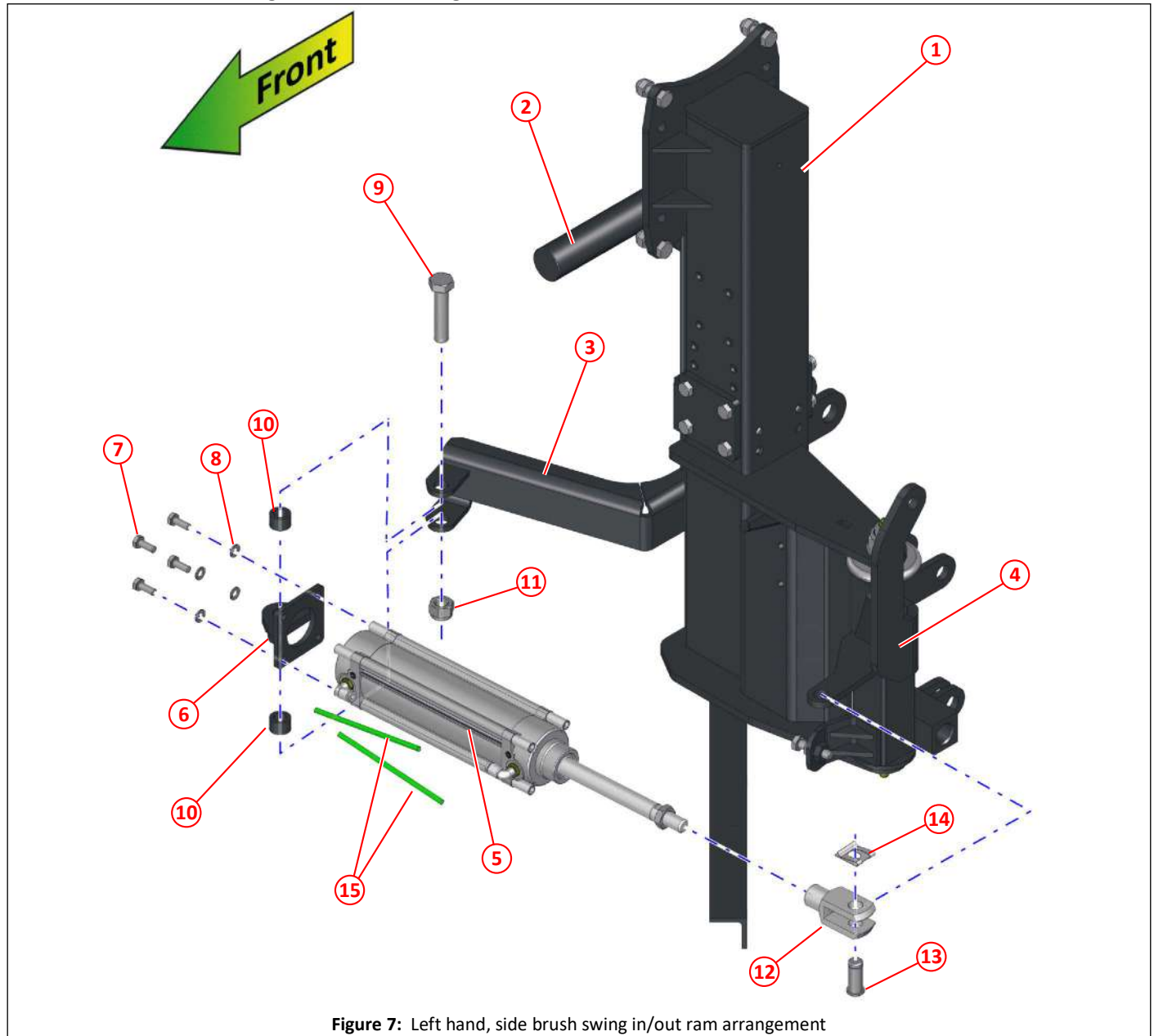

Figure 7: Left hand, side brush swing in/out ram arrangement

Item	Part No	Qty	Description
①	046841	1	Left hand leg
②	034334	1	Left hand central brush (wide sweep) adjustable mount
③	047065	1	Left hand side brush deployment ram mounting bracket
④	047024	1	King post, left hand side brush
⑤	028306	1	Pneumatic cylinder $\phi 63 \times 160$
⑥	031052	1	Ram end $\phi 63$
⑦	011010	4	Set screw M8 x 20
⑧	011093	4	Spring washer M8
⑨	011260	1	Bolt, M16 x 70
⑩	011000	2	Hose $\frac{5}{8}$ " fuel, SAE100R6, cut to 15mm
⑪	011060	1	Nyloc nut T M16
⑫	020299	1	Clevis, pneumatic, M16 x 1.5
⑬	022673	1	Clevis pin (turned)
⑭	022674	1	Retaining clip M16
⑮	024650	2	6mm green air pipe, length as required

Left hand, side brush, raise/lower, brush link

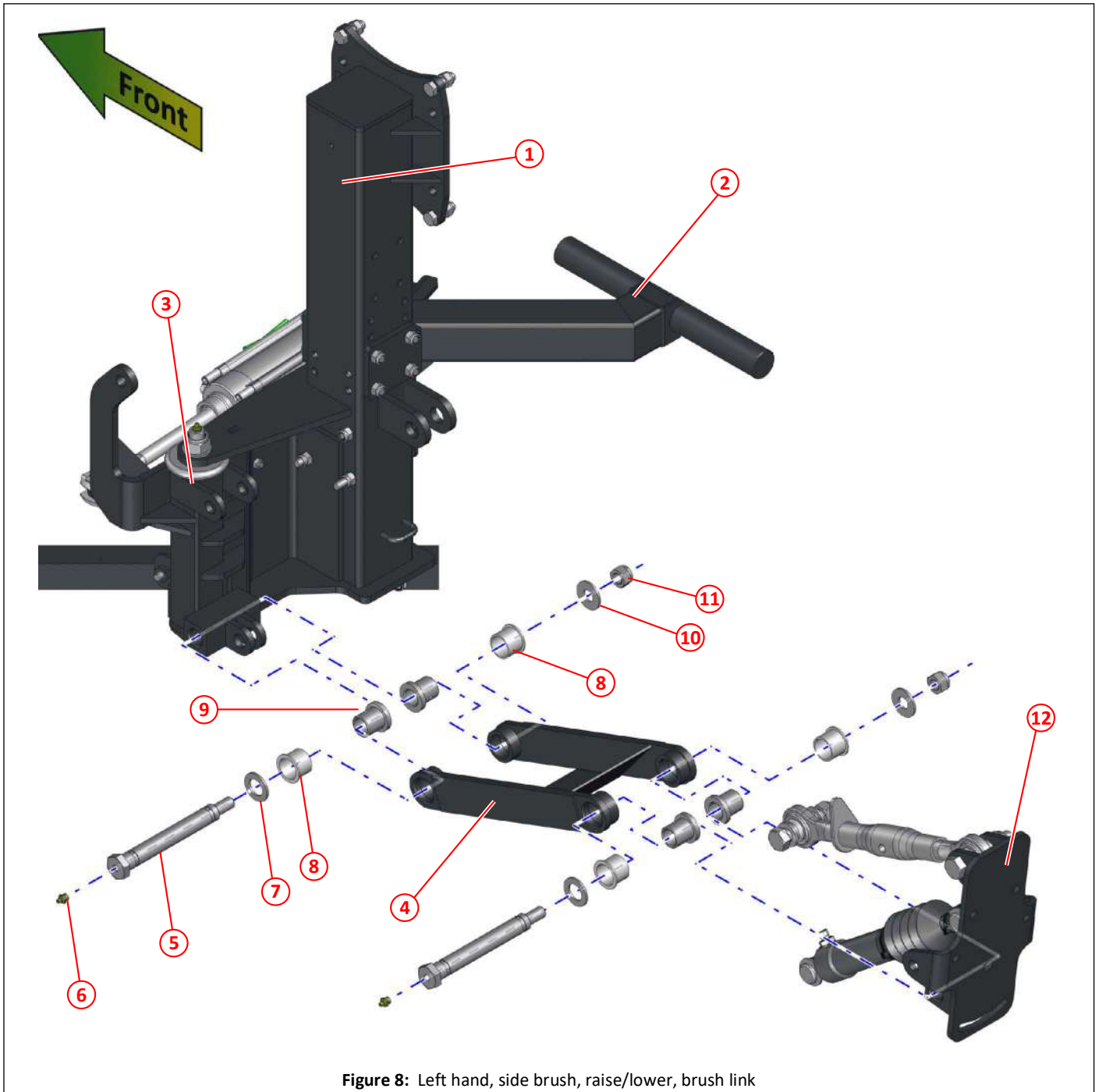

Figure 8: Left hand, side brush, raise/lower, brush link

Item	Part No	Qty	Description
①	046841	1	Left hand leg
②	034334	1	Left hand central brush (wide sweep) adjustable mount
③	047024	1	King post, left hand side brush
④	014801	1	Brush link, side brush
⑤	014796	2	Pivot bolt, brush link
⑥	010903	2	Grease nipple $\frac{1}{8}$ " BSP, straight
⑦	014798	2	Washer 24 x 40 x 3
⑧	013012	4	Bush
⑨	014799	4	Spacer sleeve, brush link
⑩	014797	1	Washer 17 x 4 x 3
⑪	011060	1	Nyloc nut T M16
⑫	046284	1	Swivel plate, side brush

Left hand, side brush raise/lower, top link

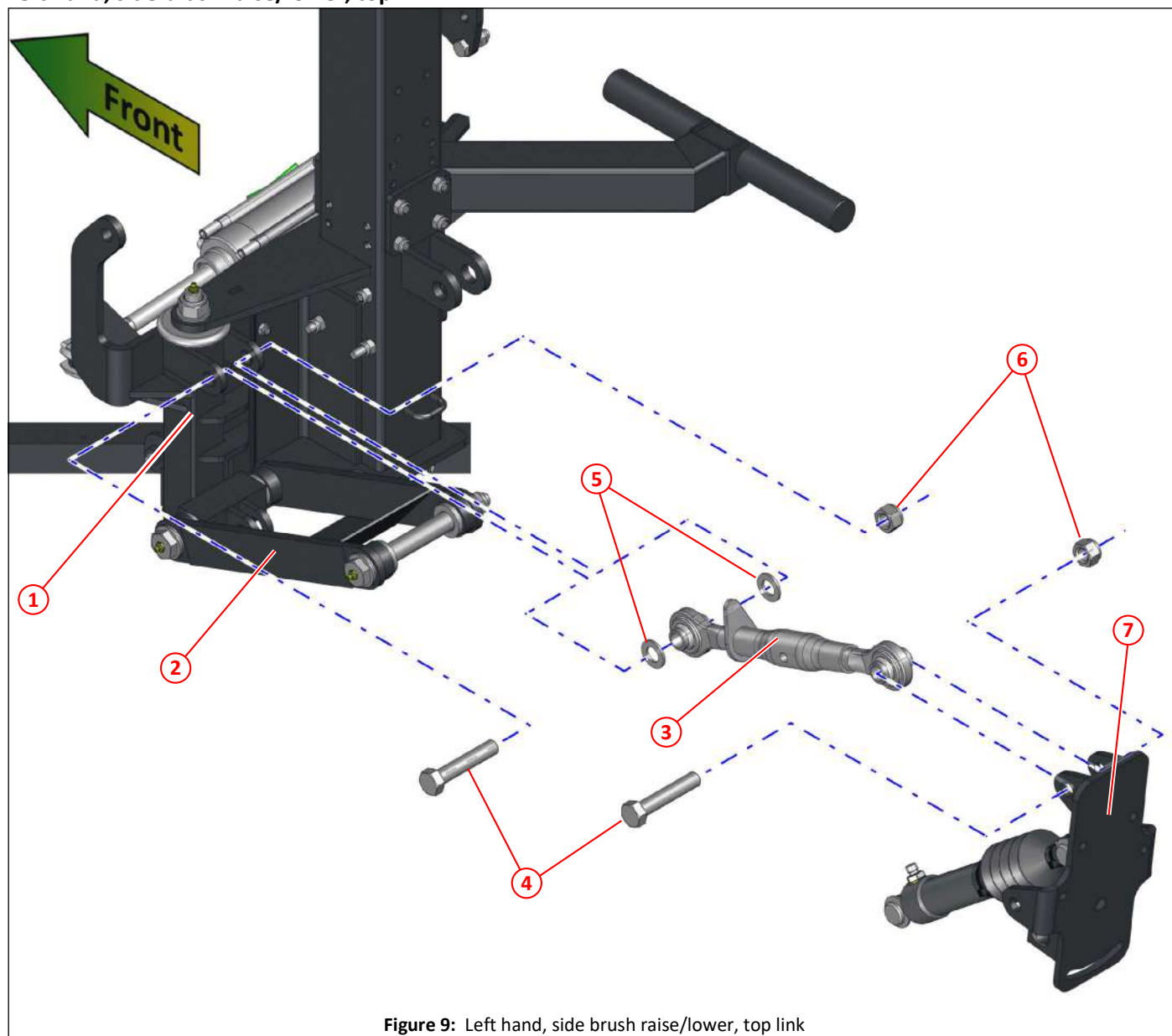

Figure 9: Left hand, side brush raise/lower, top link

Item	Part No	Qty	Description
①	047024	1	King post, left hand side brush
②	014801	1	Brush link, side brush
③	013011	1	Top link (turnbuckle), side brush
④	011140	1	Bolt M18 x 90
⑤	013011	1	Washer, plain, M18
⑥	011139	2	Nyloc nut T M18
⑦	046284	1	Swivel plate, side brush

Left hand, side brush, raise/lower ram

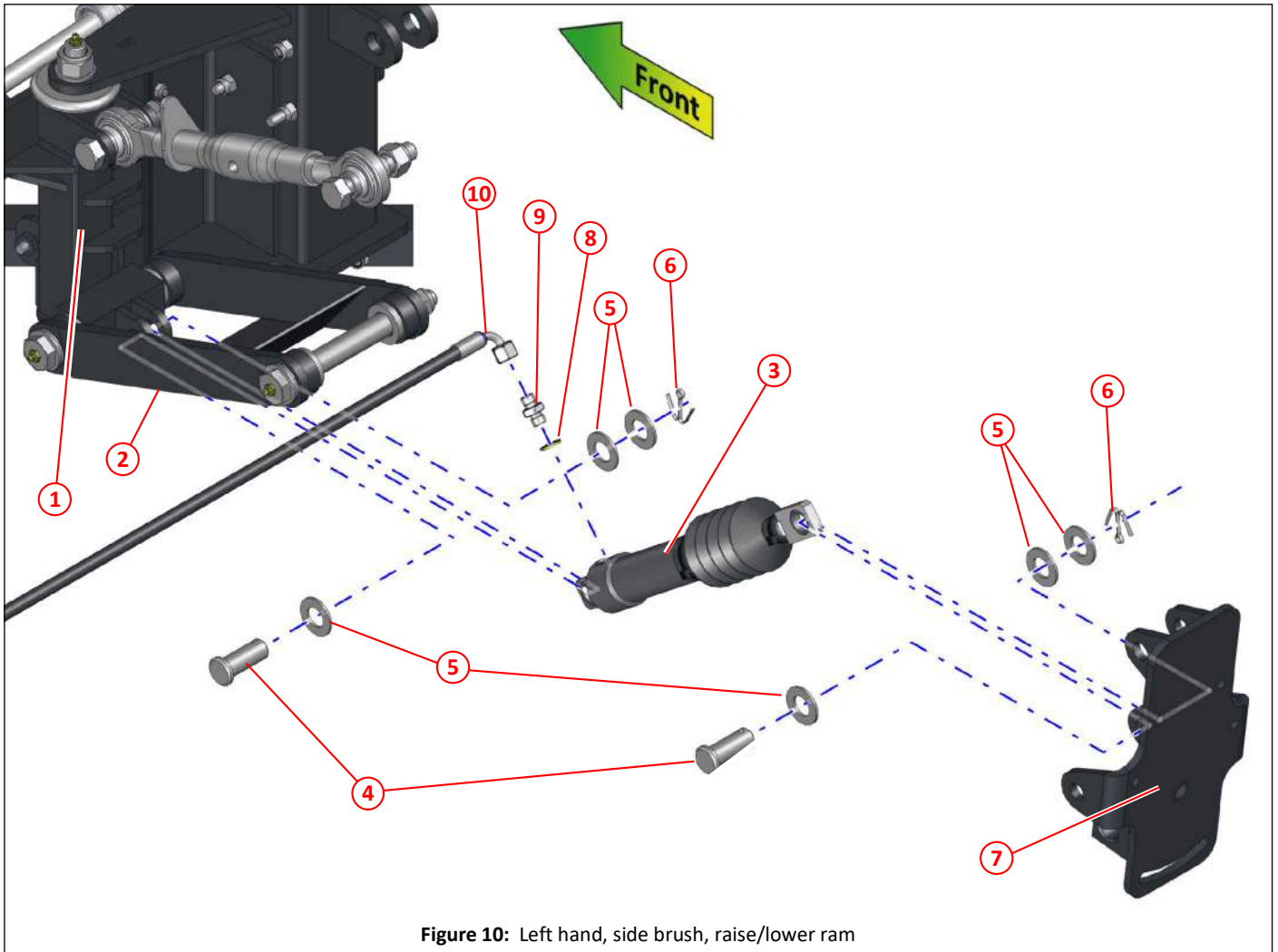

Figure 10: Left hand, side brush, raise/lower ram

Item	Part No	Qty	Description
①	047024	1	King post, left hand side brush
②	014801	1	Brush link, side brush
③	024539	1	Ram No. 12 240/340 assembly
④	046750	2	Clevis pin, $\varnothing 20 \times 50$
⑤	011102	6	Washer, plain, M20
⑥	011122	2	Split pin, $\frac{3}{16}'' \times 1\frac{1}{2}''$
⑦	046284	1	Swivel plate, side brush
⑧	011152	1	Dowty seal $\frac{1}{4}''$ BSP
⑨	012539	1	Restrictor No 5 $\frac{1}{4}''$ BSP x $\frac{1}{4}''$ BSP $\frac{1}{32}''$ white
⑩	001371	1	Hose $\frac{1}{4}''$ BSP x 1225, straight and 90°

Left hand, side brush, swivel plate

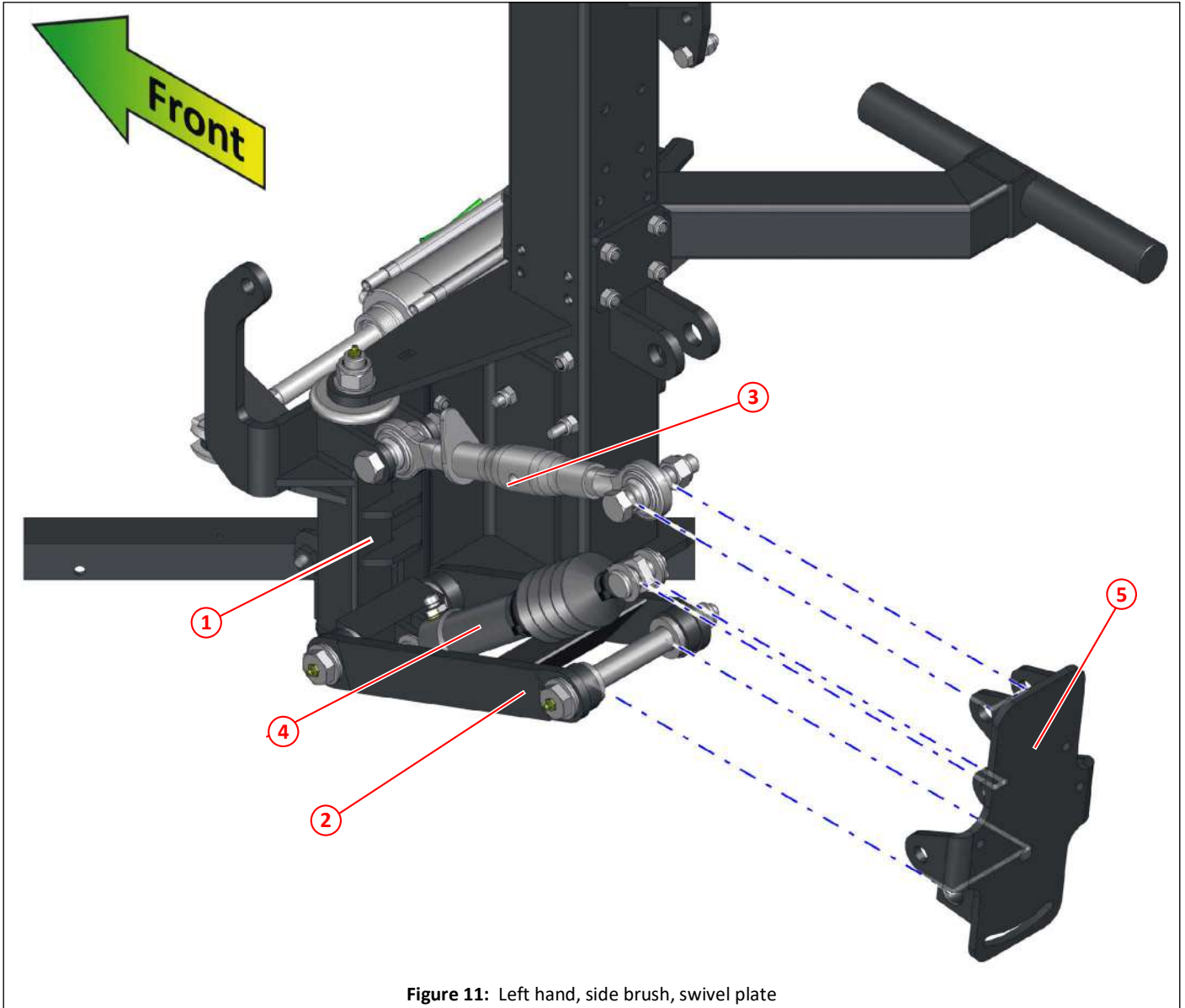

Figure 11: Left hand, side brush, swivel plate

Item	Part No	Qty	Description
①	047024	1	King post, left hand side brush
②	014801	1	Brush link, side brush
③	013011	1	Top link (turnbuckle)
④	024539	1	Ram No. 12 240/340 assembly
⑤	046284	1	Swivel plate, side brush

Left hand, side brush, pressure arrangement

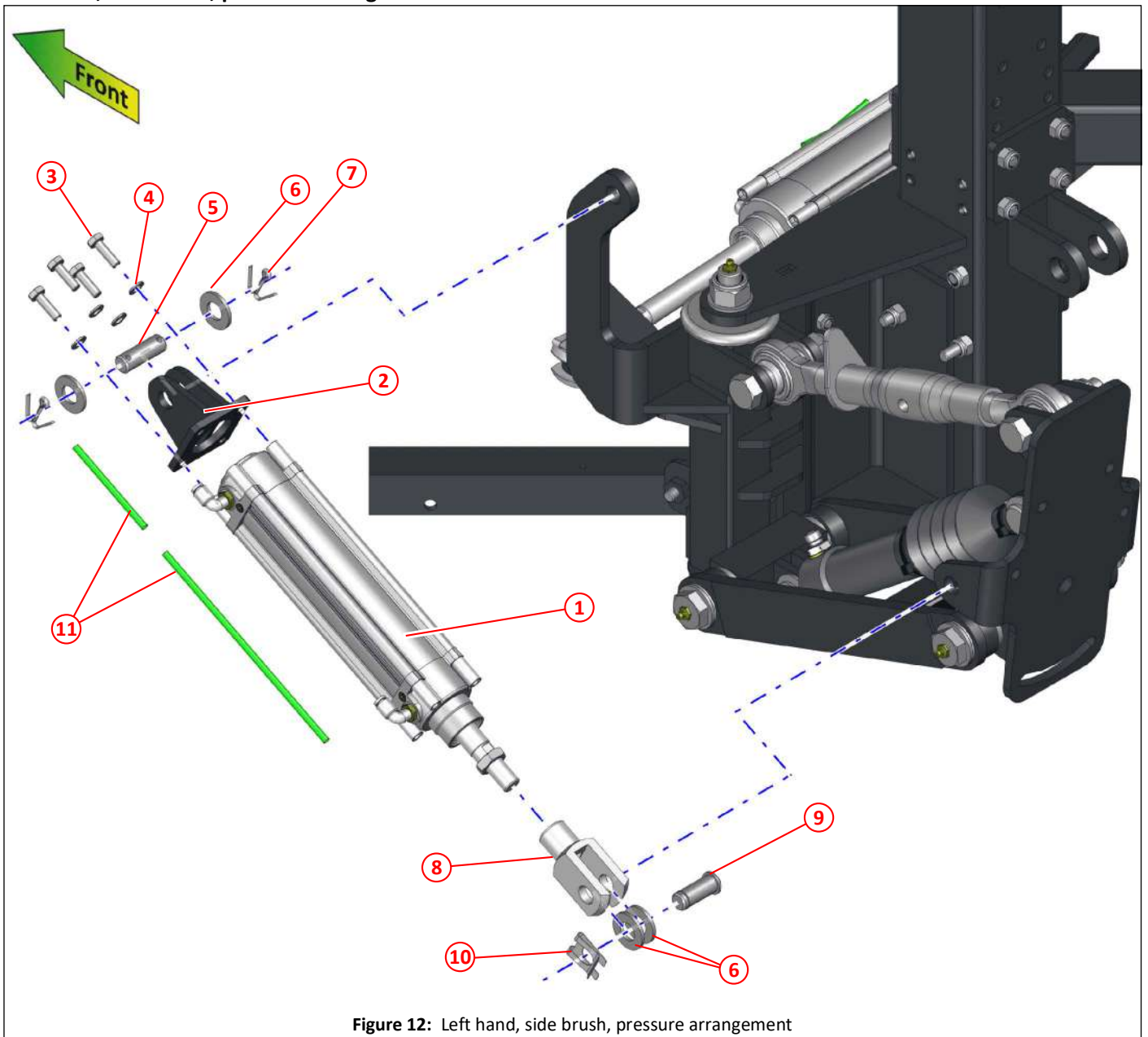

Figure 12: Left hand, side brush, pressure arrangement

Item	Part No	Qty	Description
①	020298	1	Pneumatic cylinder 50 x 160
②	023122	1	Pivot, cylinder mount bracket
③	011011	4	Setscrew M8 x 25
④	011093	4	Spring washer M8
⑤	023123	1	Pin $\varnothing 16 \times 46$
⑥	011135	4	Washer, plain, M16
⑦	011122	2	Split pin, $\frac{3}{16} \times 1\frac{1}{2}$ "
⑧	020299	1	Clevis, pneumatic, M16 x 1.5
⑨	022673	1	Clevis pin (turned)
⑩	022674	1	Retaining clip M16
⑪	024650	2	6mm green air pipe, length as required

Left hand, side brush, leg hose tidy

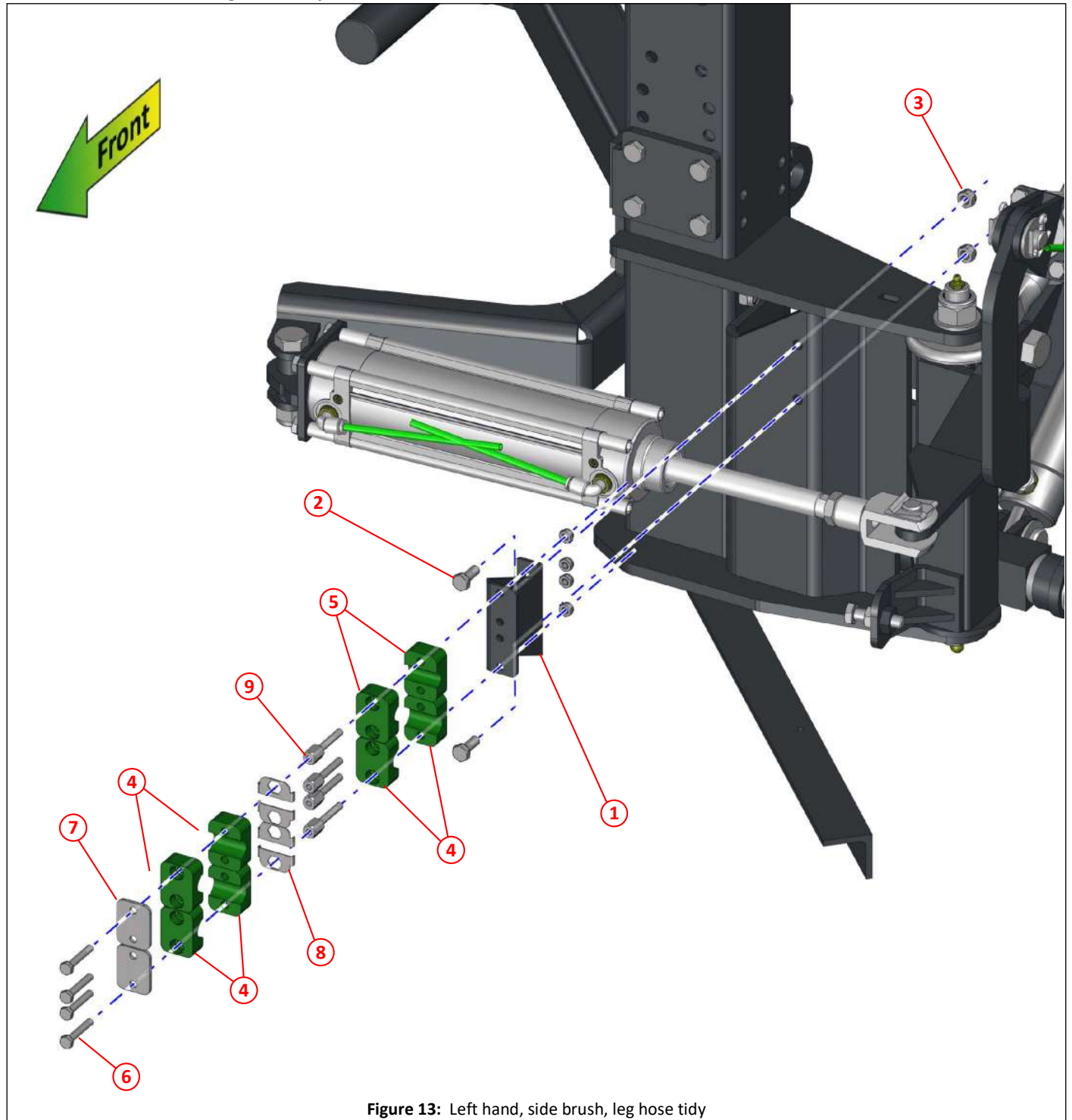

Figure 13: Left hand, side brush, leg hose tidy

Item	Part No	Qty	Description
①	047228	1	Left hand leg, hose tidy
②	011010	2	Set screw M8 x 20
③	011073	2	Nyloc nut T M8
④	002163	6	Pipe clamp block, 17.2 single pipe/hose
⑤	031316	2	Pipe clamp block, 1/4" single pipe/hose
⑥	011068	4	Bolt M6 x 35
⑦	031317	2	Clamp plate flat
⑧	000472	4	Locking plate SIG1
⑨	000470	4	Stacking bolt, 35mm (AF4)
⑩	011071	4	Nyloc nut T M6

Left hand, side brush skirt

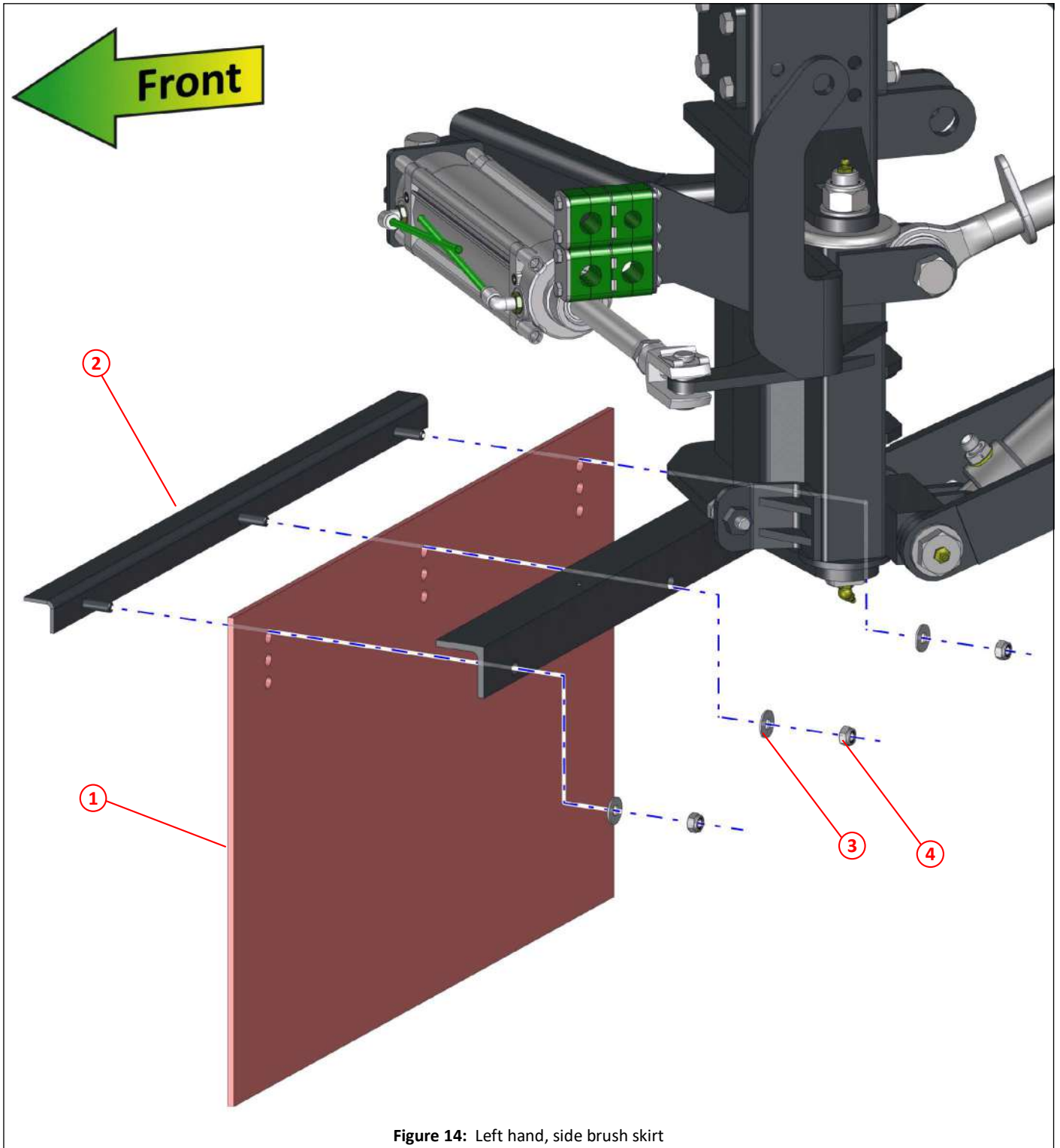
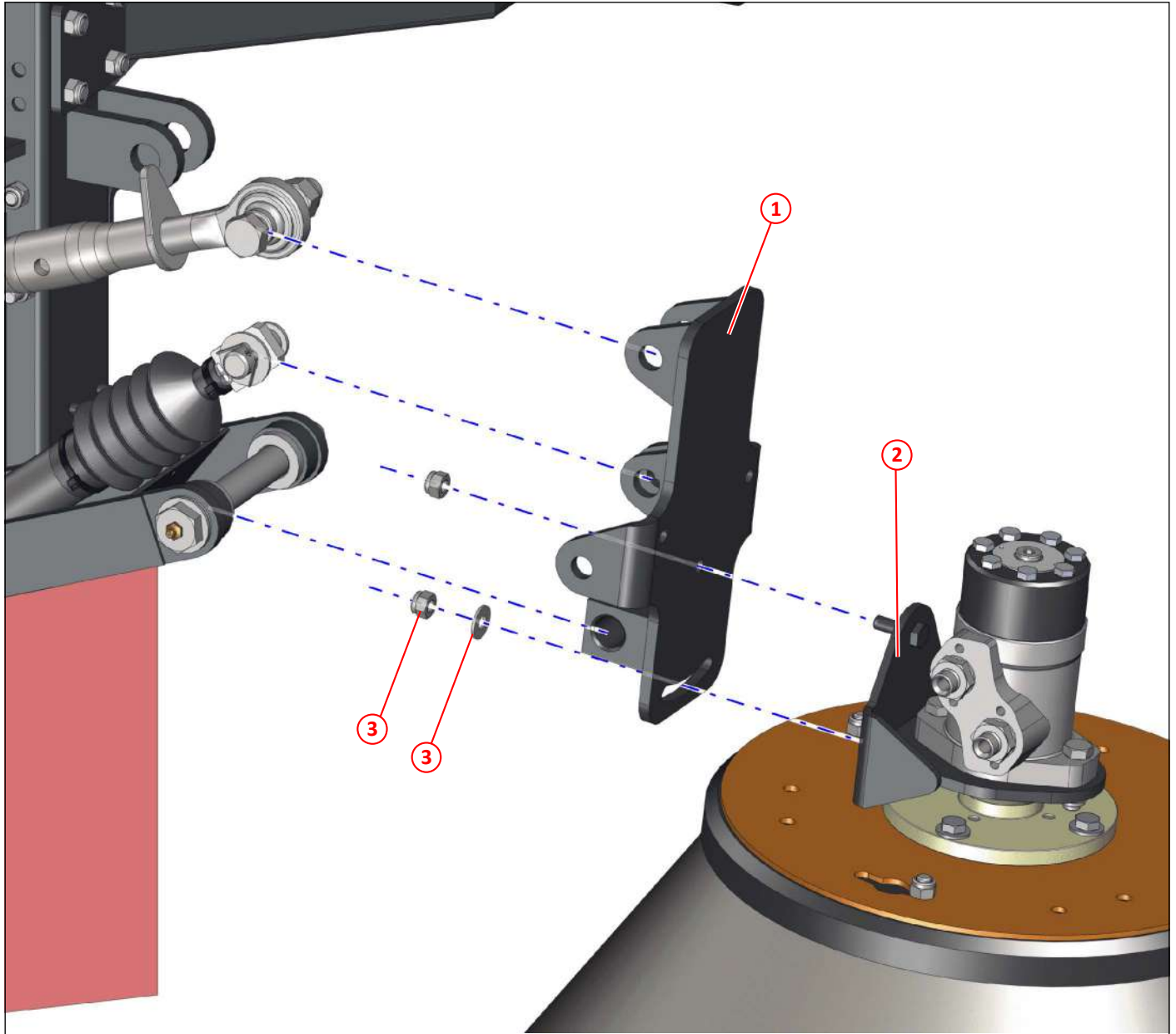

Figure 14: Left hand, side brush skirt

Item	Part No	Qty	Description
①	010247	1	Skirt, side brush, 3-pitch, heavy duty
②	010275	1	Skirt clamp
③	011092	3	Washer, plain, M8
④	011073	3	Nyloc nut T M8

Left hand, side brush, swivel plate attach (non tilting)



i Non tilting side brush is the standard fitment.

Figure 15: Left hand, side brush, swivel plate attach (non tilting)

Item	Part No	Qty	Description
①	046284	1	Swivel plate, side brush
②	010007	1	Motor bracket, side brush
③	011094	1	Washer, plain, M10
④	011075	2	Nyloc nut T M10

Left hand, side brush motor (non tilting)

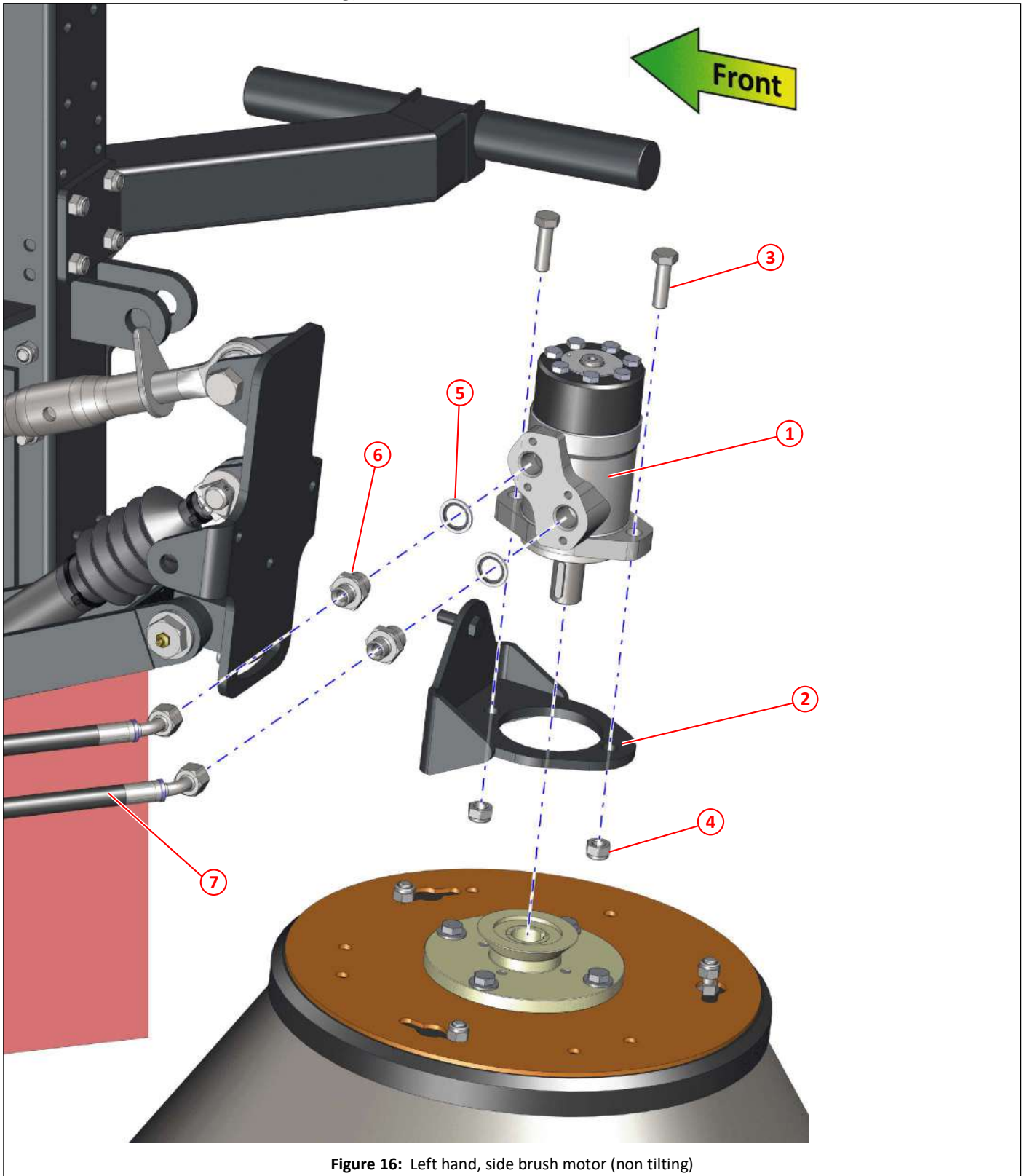

Figure 16: Left hand, side brush motor (non tilting)

Item	Part No	Qty	Description
①	010749	1	Motor 3597 (OMP 200)
②	010007	1	Motor bracket, side brush
③	011069	2	Bolt M12 x 40
④	011077	2	Nyloc nut T M12
⑤	011154	2	Dowty seal $\frac{1}{2}$ " BSP
⑥	011167	2	Adapter $\frac{1}{2}$ " x $\frac{3}{8}$ " BSP
⑦	001372	2	Hose $\frac{3}{8}$ " BSP x 1400, straight and 45°

Left hand, side brush, swivel plate attach (tilting)

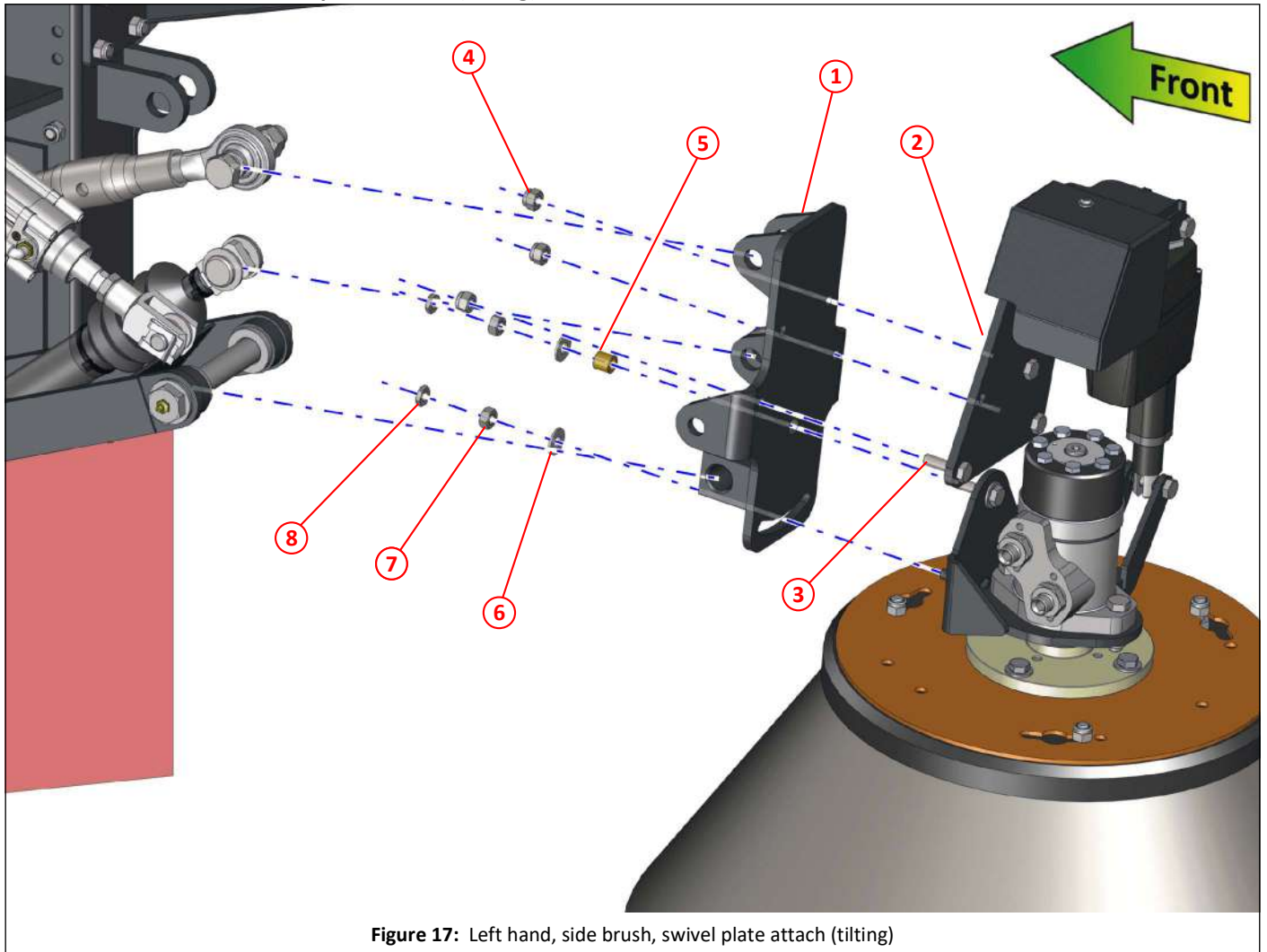

Figure 17: Left hand, side brush, swivel plate attach (tilting)

Item	Part No	Qty	Description
①	046284	1	Swivel plate, side brush
②	046279	1	Brush tilt bracket, left hand
③	011033	4	Setscrew M10 x 35
④	011075	3	Nyloc nut T M10
⑤	046282	1	Bush 16 x 10.5 x 15
⑥	011094	2	Washer, plain, M10
⑦	011074	2	Full nut M10
⑧	000506	2	Half nut M10

Left hand, side brush tilt (tilting)

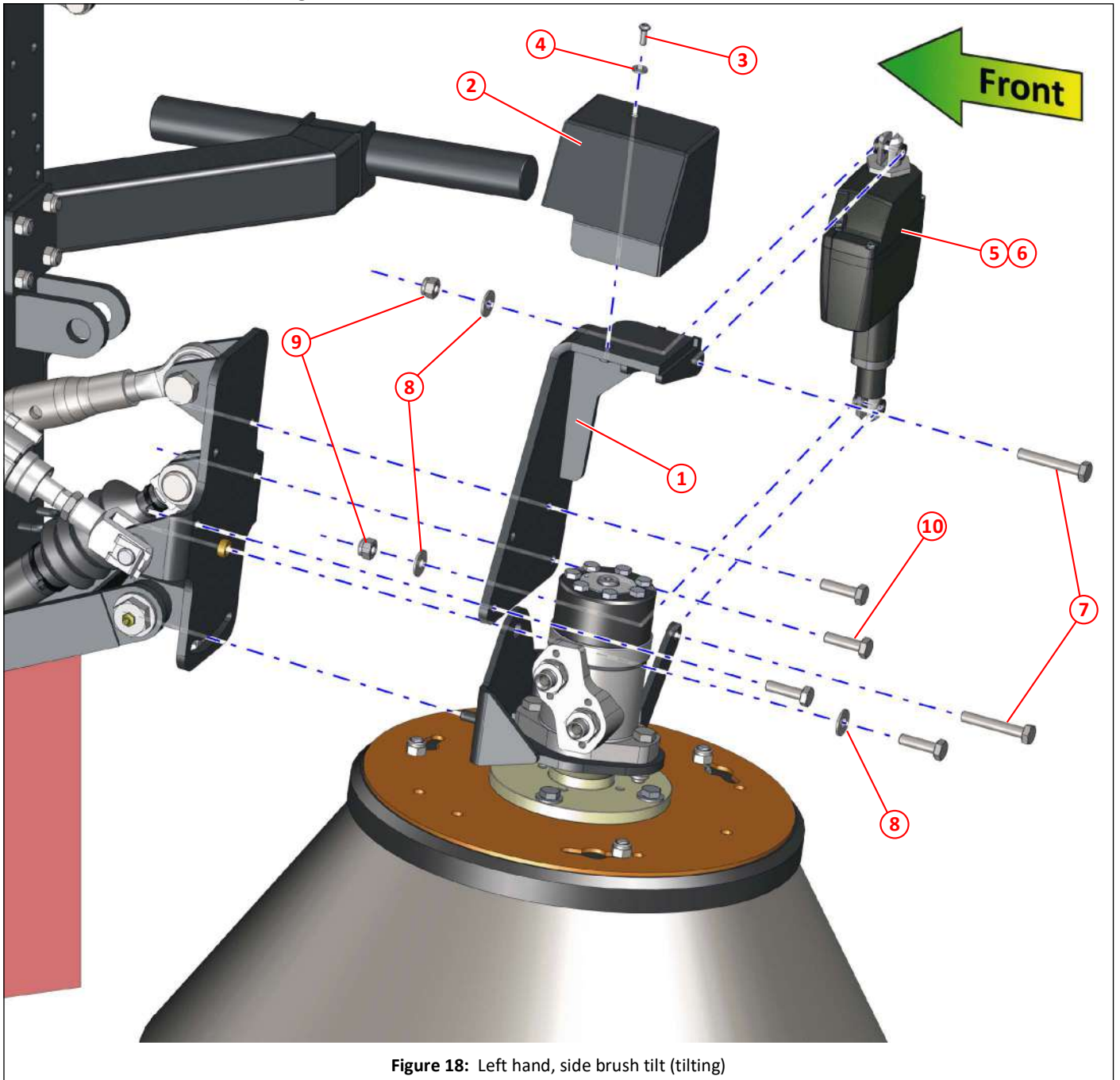

Figure 18: Left hand, side brush tilt (tilting)

Item	Part No	Qty	Description
①	046279	1	Brush tilt bracket, left hand
②	046491	1	Actuator cover, left hand
③	000373	1	Socket dome head screw M6 x 16, stainless steel
④	000254	1	Plain washer, M6, stainless steel
⑤	046270	1	LA25/100 Actuator (12V)
⑥	047660	1	LA25/100 Actuator (24V)
⑦	011036	2	Bolt M10 x 60
⑧	011094	3	Plain washer, M10
⑨	011075	2	Nyloc nut T M10
⑩	011033	4	Setscrew M10 x 35

Left hand, side brush motor (tilting)

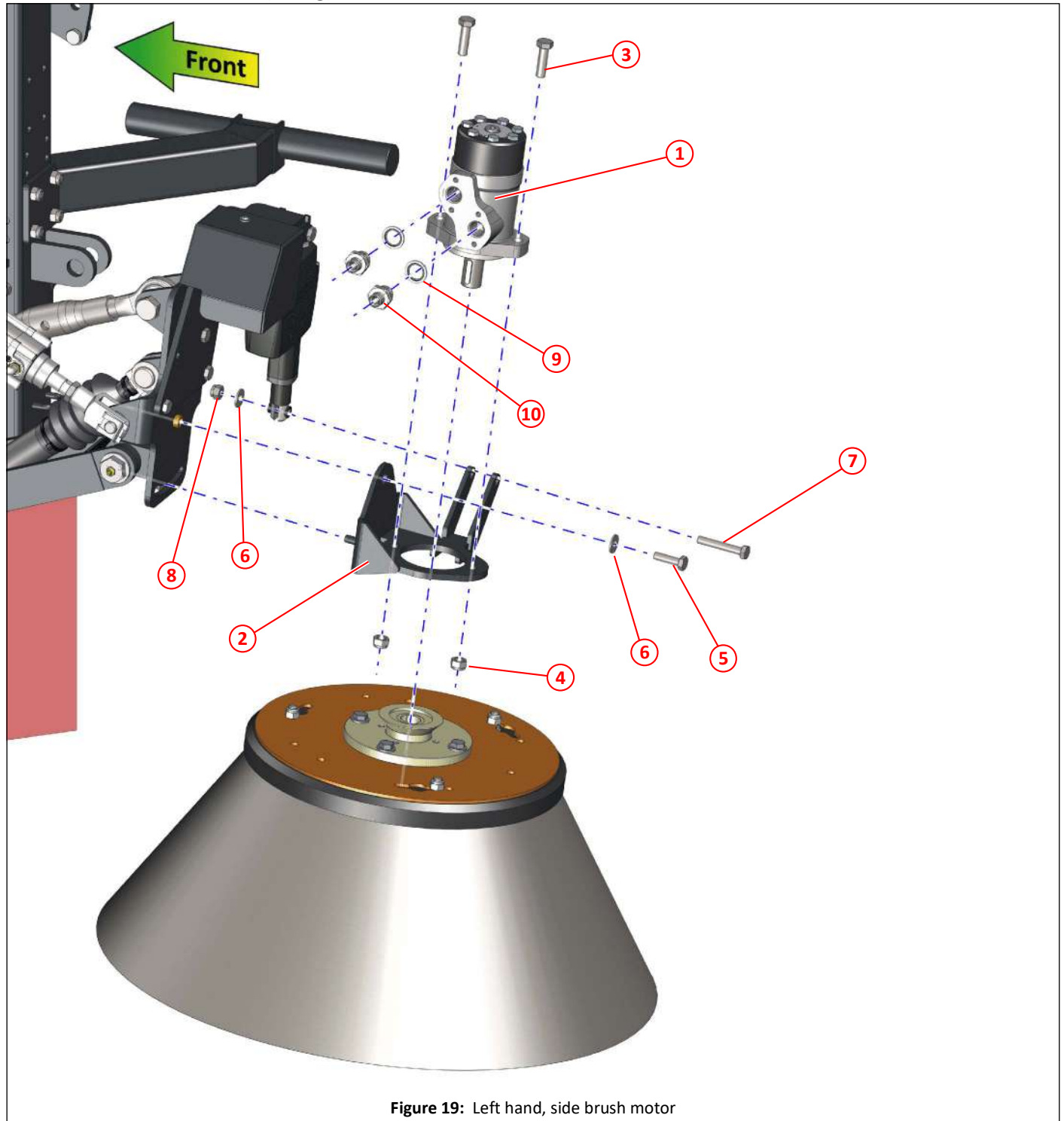

Figure 19: Left hand, side brush motor

Item	Part No	Qty	Description
①	010749	1	Motor 3597 (OMP 200)
②	047533	1	Motor bracket tilting side brush, bolt hub, left hand
③	011069	2	Bolt M12 x 40
④	011077	2	Nyloc nut T M12
⑤	011033	1	Setscrew M10 x 35
⑥	011094	2	Plain washer, M10
⑦	011036	1	Bolt M10 x 60
⑧	011075	1	Nyloc nut T M10
⑨	011154	2	Dowty seal $\frac{1}{2}$ " BSP
⑩	011167	2	Adapter $\frac{1}{2}$ " x $\frac{3}{8}$ " BSP

Left hand, side brush, brush hub: superseded

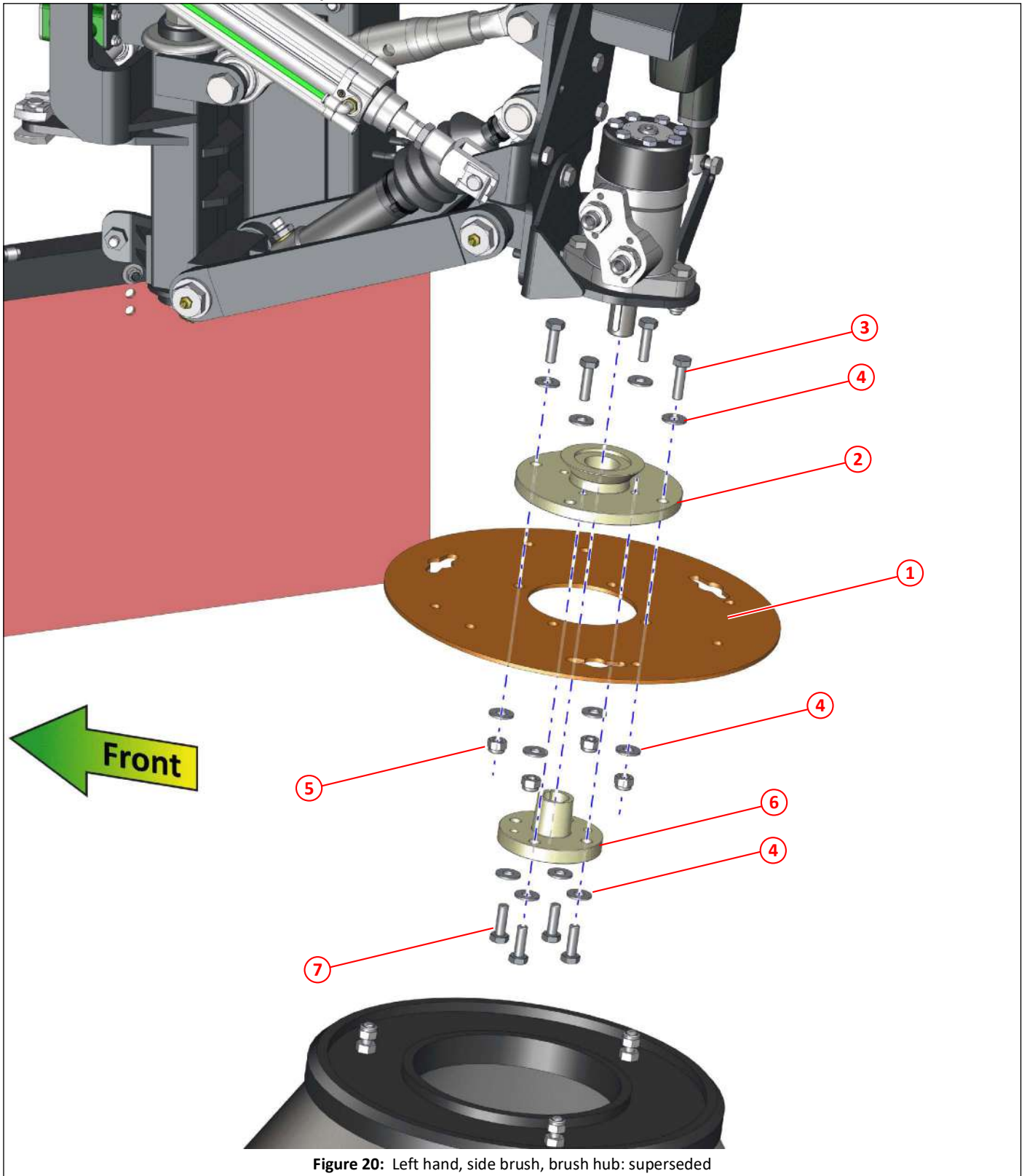

Figure 20: Left hand, side brush, brush hub: superseded

i The above brush hub has been superseded and the parts are no longer available. See page 38 for new components to replace the above. For further information please contact the Scarab Parts Department.

Left hand, side brush, brush hub: revised

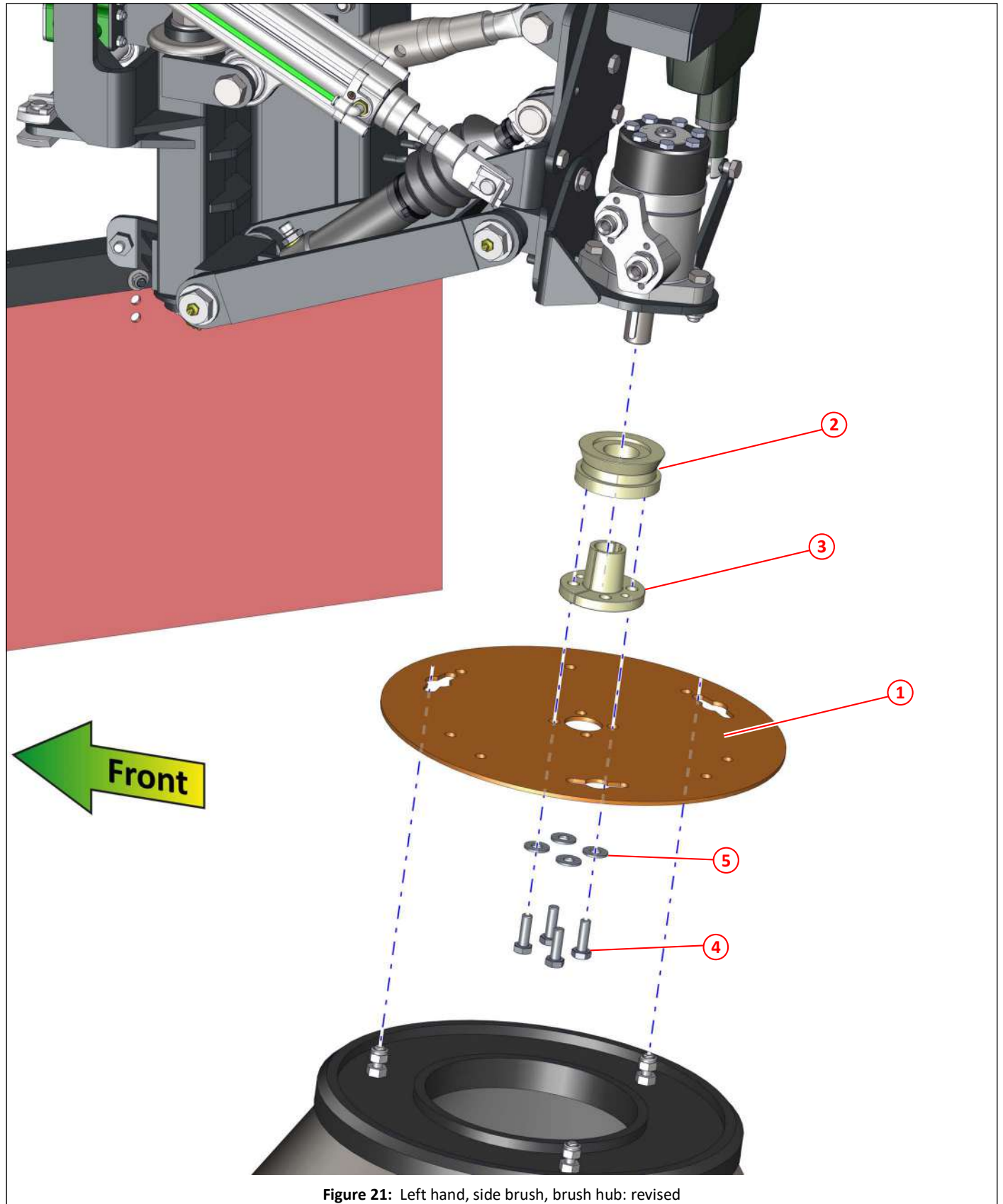

Figure 21: Left hand, side brush, brush hub: revised

Item	Part No	Qty	Description
①	047484	1	Brush hub 7000 / side brush (bolt hub)
②	047482	1	Plate hub
③	047481	1	Sprung hub
④	000461	4	Setscrew, HT, M10 x 30, stainless steel
⑤	000270	4	Washer M10, stainless steel

Left hand, side brush, water jets mounting

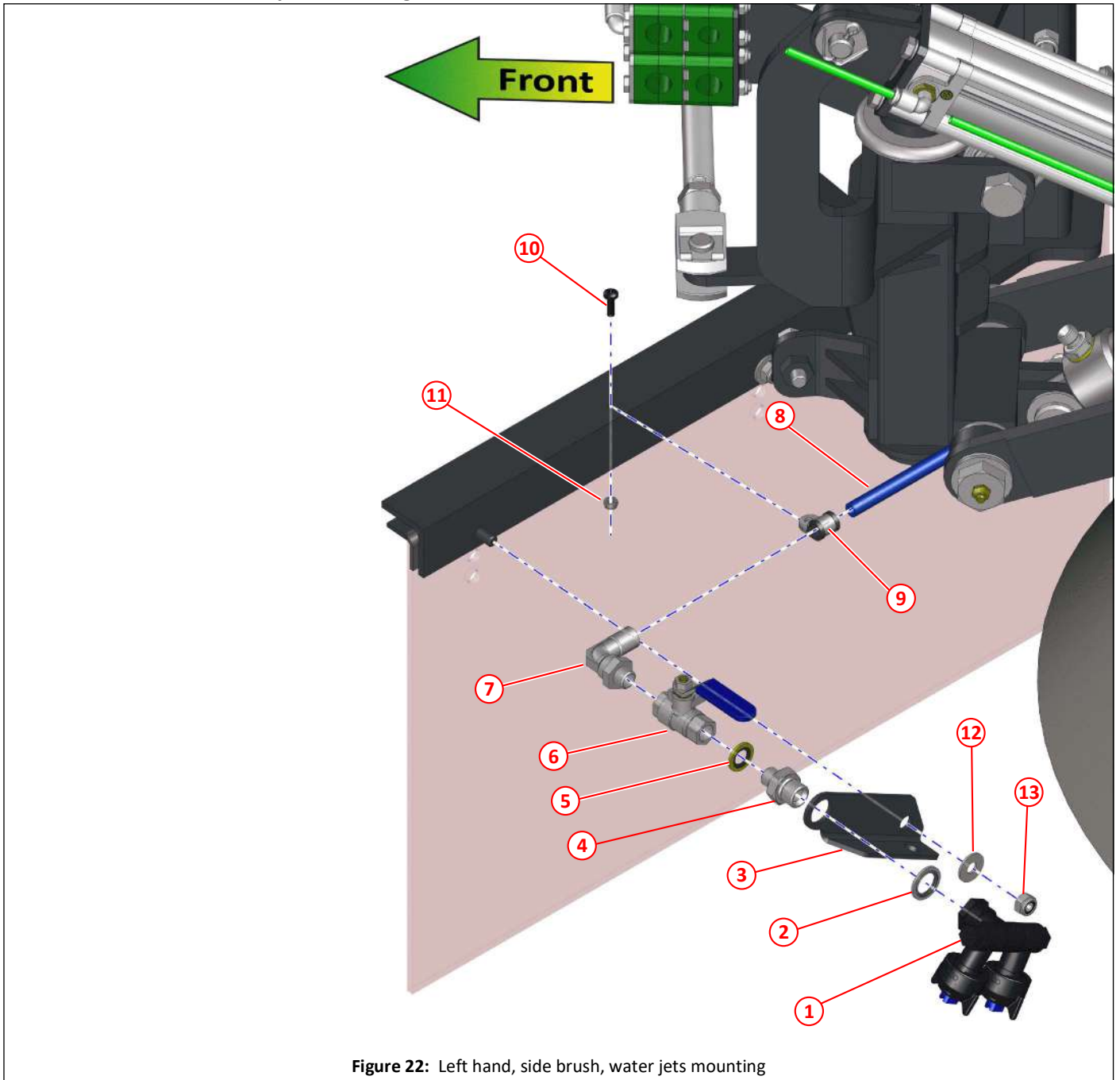
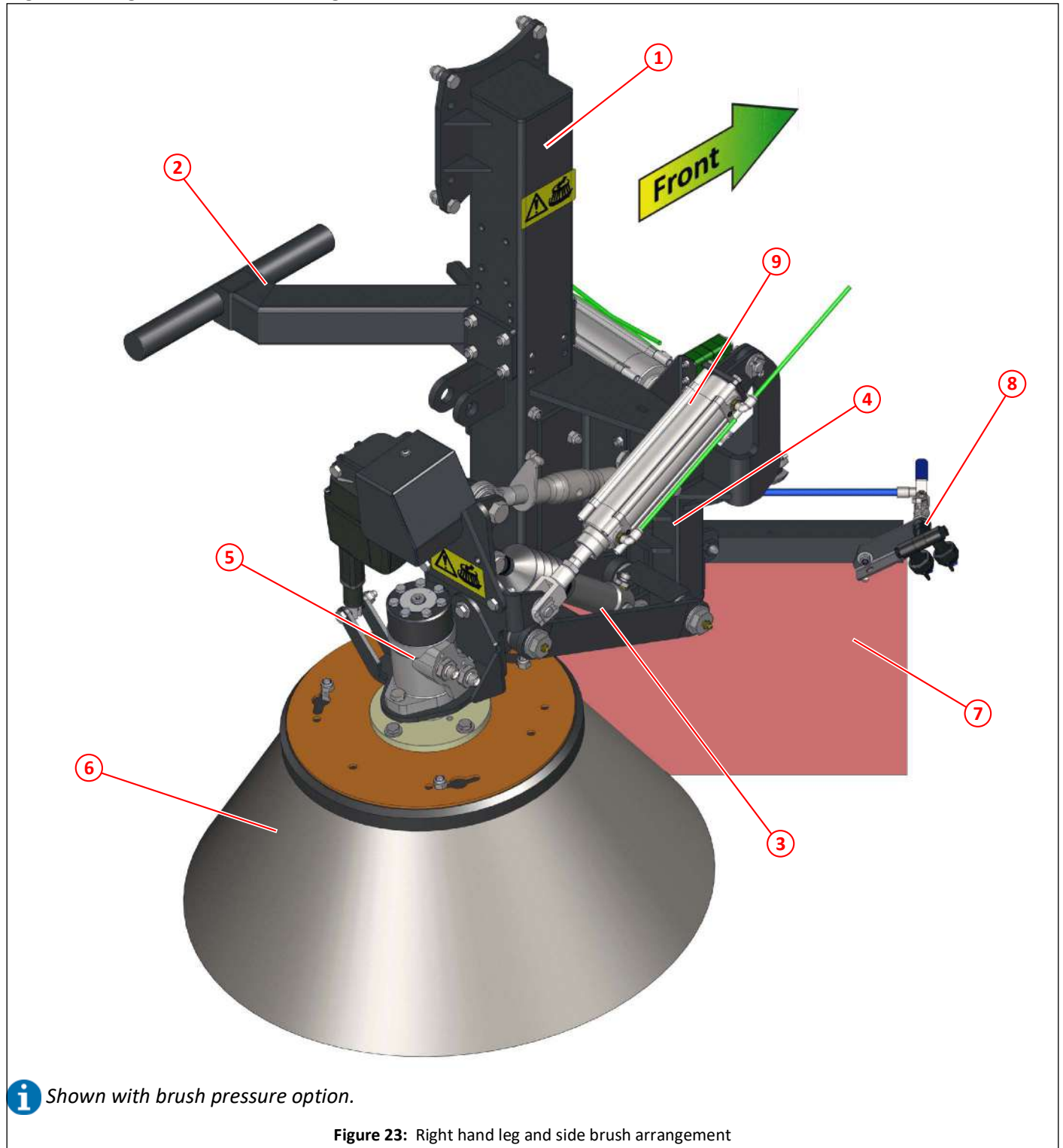

Figure 22: Left hand, side brush, water jets mounting

Item	Part No	Qty	Description
①	036044	1	Water jets, double swivel nozzle holder assembly
②	011153	1	Dowty seal $\frac{3}{8}$ " BSP
③	036042	1	Nozzle bracket, twin nozzle
④	011199	1	Adapter $\frac{3}{8}$ " BSP x $\frac{1}{4}$ " BSP
⑤	011152	1	Dowty seal $\frac{1}{4}$ " BSP
⑥	011743	1	Valve, ball, $\frac{1}{4}$ " BSP
⑦	047602	1	Adapter, angle, 90° push in 10mm x $\frac{1}{4}$ " BSP
⑧	041031	1	Blue flexible nylon tubing, \varnothing 10mm, (length as required)
⑨	021914	1	P-clip \varnothing 12mm, rubber sealed
⑩	000234	1	Setscrew, pan head pozidriv, M5 x 16, black
⑪	000155	1	Nyloc nut M5
⑫	011092	1	Plain washer M8
⑬	011073	1	Nyloc nut T M8

Right hand leg and side brush arrangement



Item	Part No	Qty	Description	
①	046842	1	Right hand leg	41
②	034335	1	Right hand central brush (wide sweep) adjustable mount	41,42
③			Right hand side brush raise/lower assembly	46,47,48,49
④			Right hand side brush king post, swing in/out arrangement	43,44,45
⑤			Side brush motor assembly	54,57
⑥			Side brush	62
⑦			Front skirt, side brush	52
⑧			Side brush dual water spray	61
⑨			Side brush pressure cylinder (option)	50

Right hand leg and central brush mount

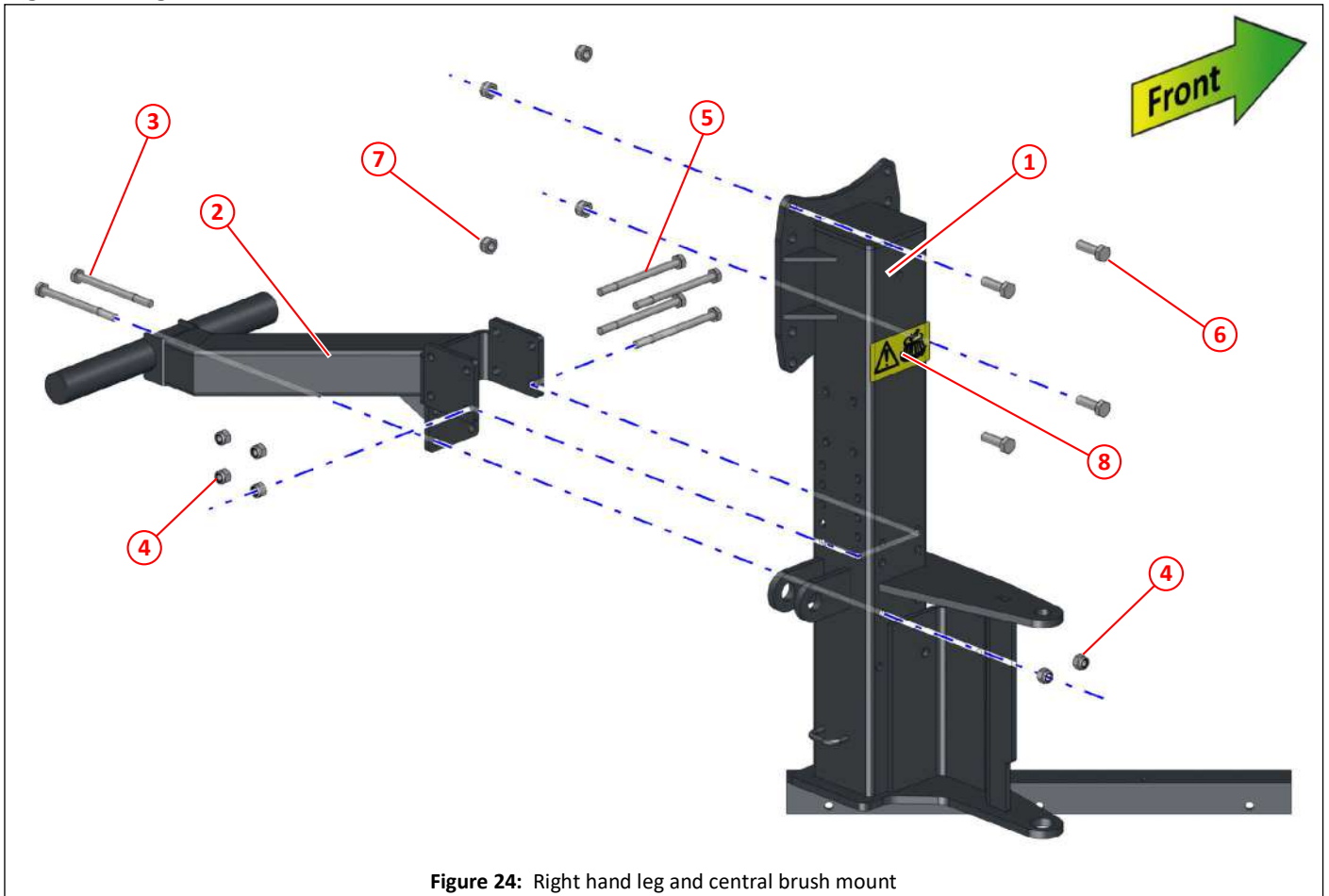

Figure 24: Right hand leg and central brush mount

Item	Part No	Qty	Description	
①	046842	1	Right hand leg	
②	034335	1	Right hand central brush (wide sweep) adjustable mount	
③	011407	2	Bolt M10 x 120	
④	011075	6	Nyloc nut T M10	
⑤	000075	4	Bolt M10 x 130	
⑥	011053	4	Setscrew M12 x 35	
⑦	011077	2	Nyloc nut T M12	
⑧	022383	1	Label - Brush Warning	

Right hand dummy leg and central brush mount

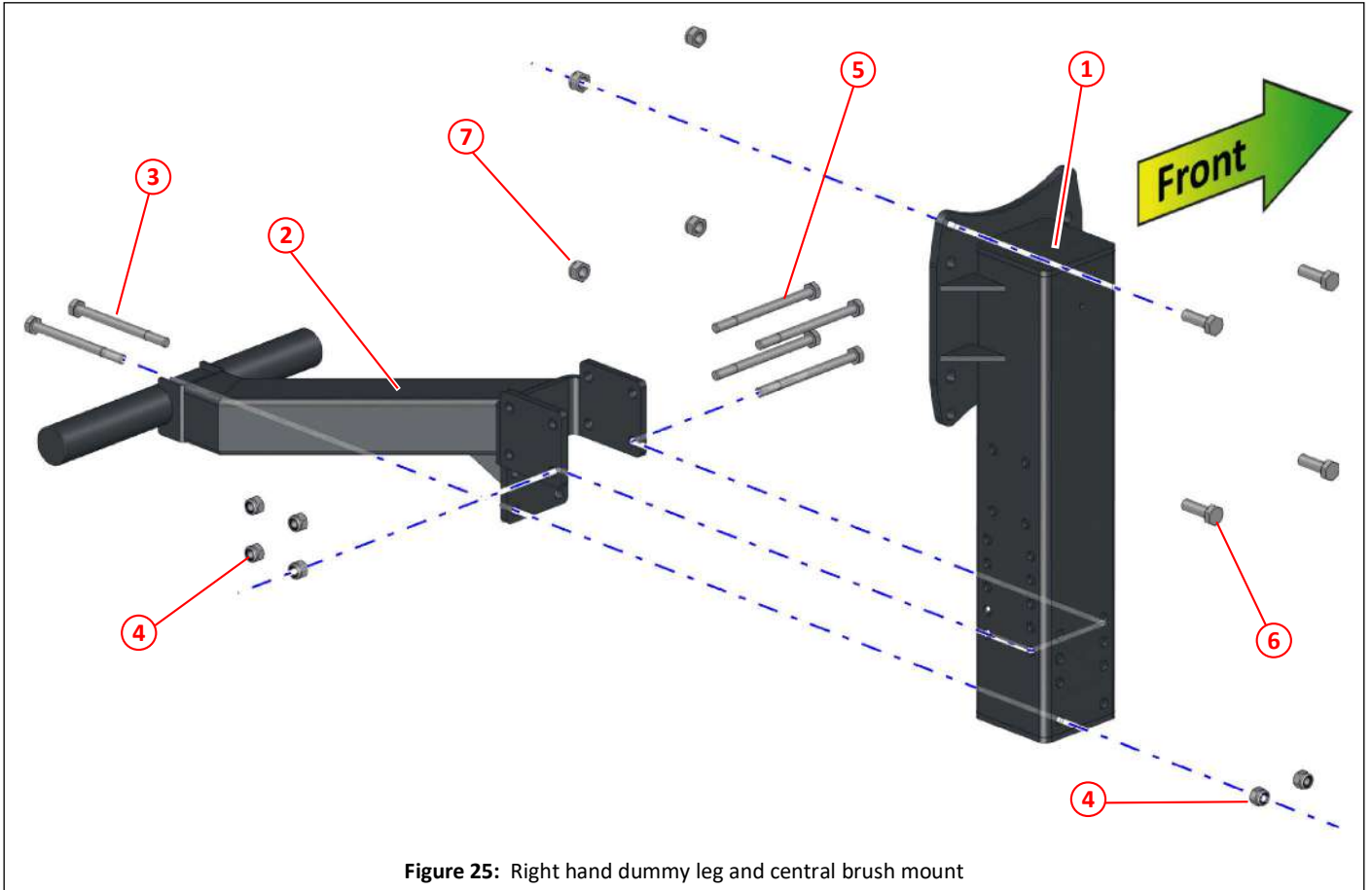

Figure 25: Right hand dummy leg and central brush mount

Item	Part No	Qty	Description
①	042867	1	Right hand dummy leg
②	034335	1	Right hand central brush (wide sweep) adjustable mount
③	011407	2	Bolt M10 x 120
④	011075	6	Nyloc nut T M10
⑤	000075	4	Bolt M10 x 130
⑥	011053	4	Setscrew M12 x 35
⑦	011077	2	Nyloc nut T M12

Right hand, side brush king post

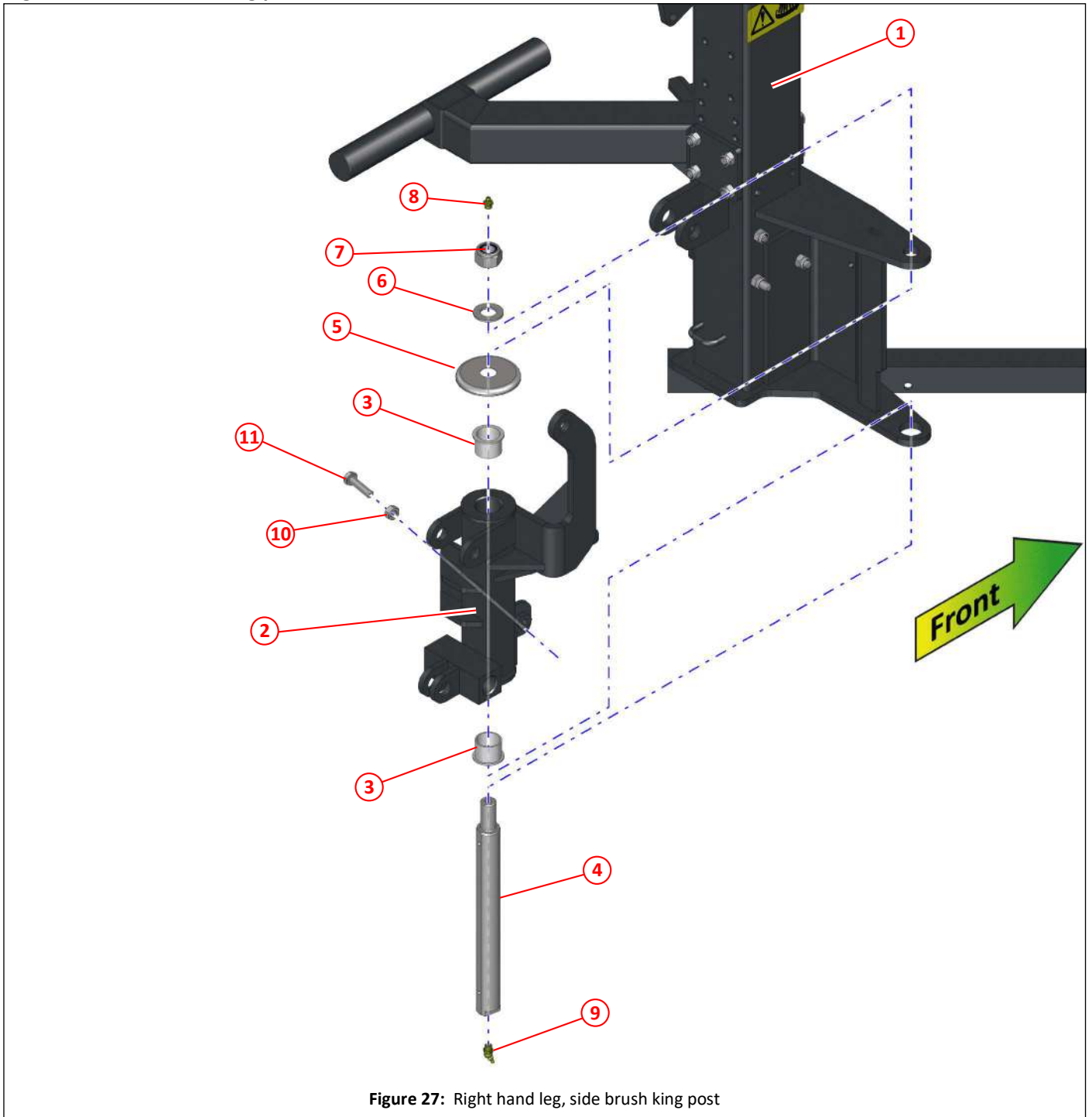

Figure 27: Right hand leg, side brush king post

Item	Part No	Qty	Description
①	046842	1	Right hand leg
②	047025	1	King post, right hand side brush
③	013012	2	Bush, king post
④	013007	1	Kin pin
⑤	013013	1	Dirt shield
⑥	011102	1	Washer M20
⑦	011082	2	Nyloc nut M20
⑧	010903	1	Grease nipple, straight, $\frac{1}{8}$ " BSP
⑨	011060	1	Grease nipple, 135°, $\frac{1}{8}$ " BSP
⑩	011074	1	Full nut M10
⑪	011034	1	Setscrew M10 x 40

Right hand, side brush deployment ram mounting bracket

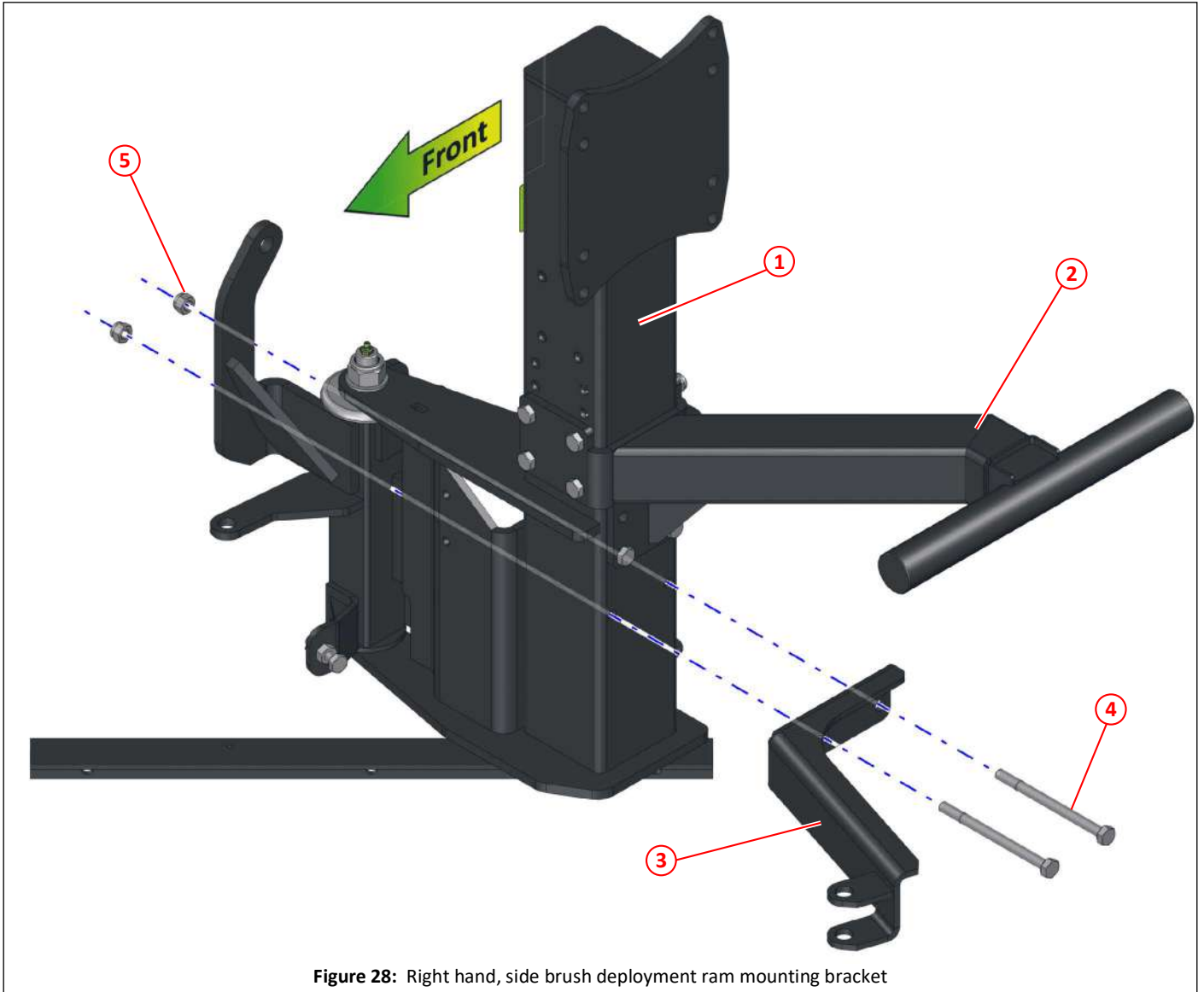

Figure 28: Right hand, side brush deployment ram mounting bracket

Item	Part No	Qty	Description	
①	046842	1	Right hand leg	
②	034335	1	Right hand central brush (wide sweep) adjustable mount	
③	047066	1	Right hand side brush deployment ram mounting bracket	
④	000075	2	Bolt M10 x 130	
⑤	011075	2	Nyloc nut T M10	

Right hand, side brush swing in/out ram arrangement

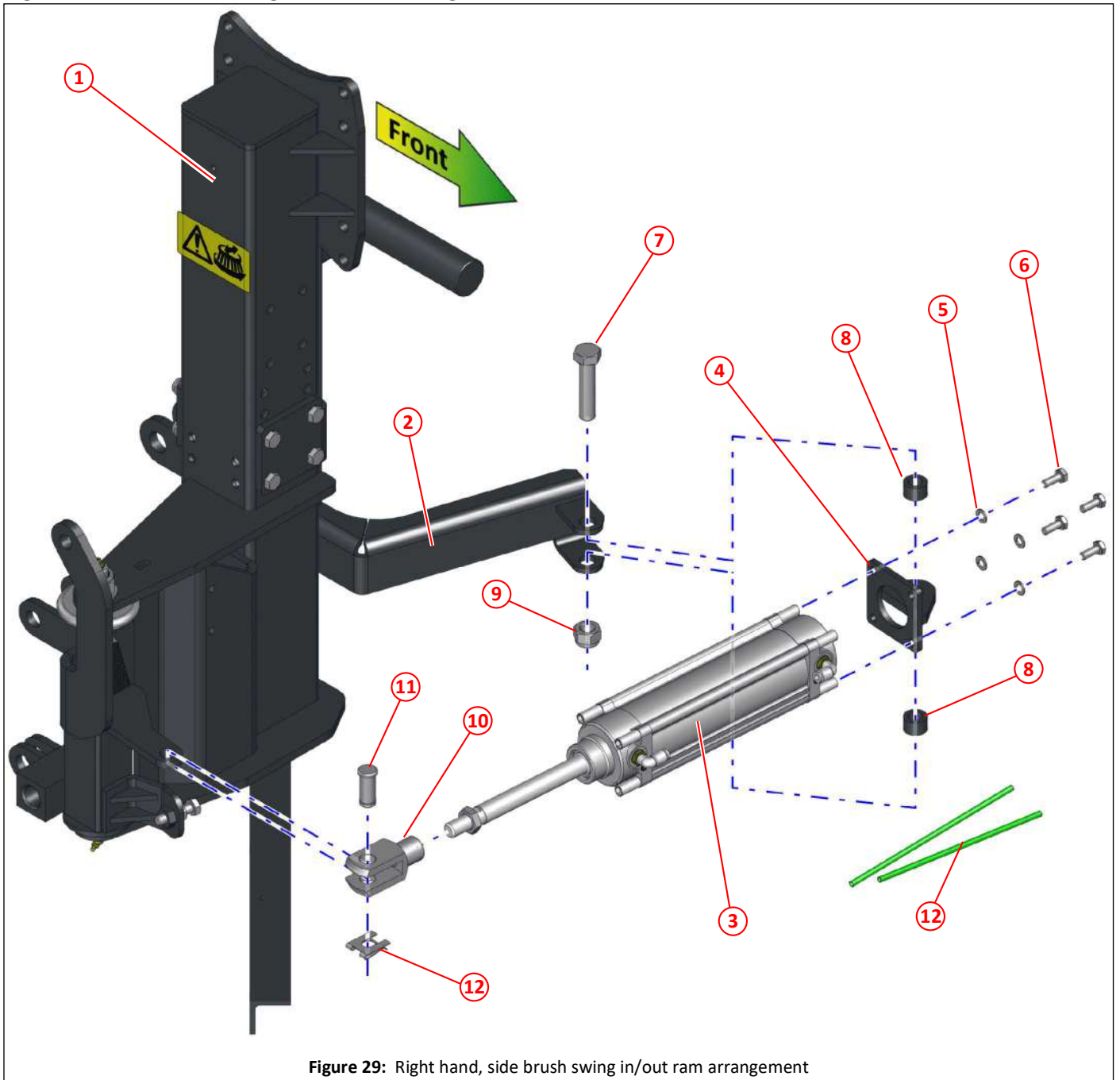

Figure 29: Right hand, side brush swing in/out ram arrangement

Item	Part No	Qty	Description
①	046842	1	Right hand leg
②	047066	1	Right hand side brush deployment ram mounting bracket
③	028306	1	Pneumatic cylinder ø63 x 160
④	031052	1	Ram end ø63
⑤	011093	4	Spring washer M8
⑥	011010	4	Setscrew M8 x 20
⑦	011260	1	Bolt M16 x 70
⑧	011000	2	Hose $\frac{5}{8}$ " , fuel SAE100R6, cut to 15mm
⑨	011060	1	Nyloc nut T M16
⑩	020299	1	Clevis pneumatic M16 x 1.5
⑪	022673	1	Clevis pin (turned)
⑫	022674	1	Clip, retaining, M16

Right hand, side brush, raise/lower, brush link

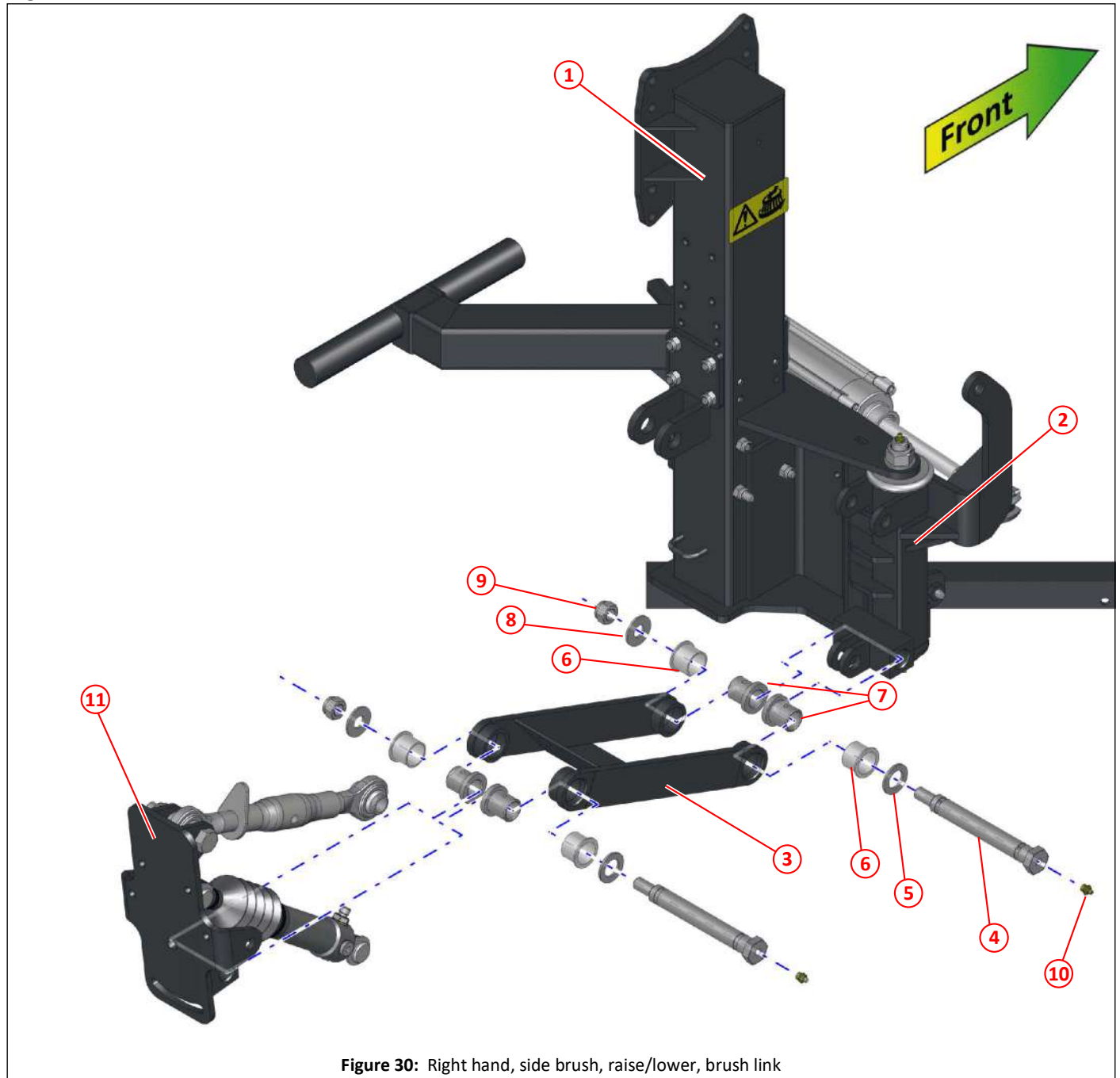

Figure 30: Right hand, side brush, raise/lower, brush link

Item	Part No	Qty	Description
①	046842	1	Right hand leg
②	047025	1	King post, right hand side brush
③	014801	1	Brush link, side brush
④	014796	2	Pivot bolt, side brush
⑤	014798	2	Washer 24 x 40 x 3
⑥	013012	4	Bush
⑦	014799	4	Spacer sleeve, side brush
⑧	014797	2	Washer 17 x 40 x 3
⑨	011060	2	Nyloc nut T M16
⑩	010903	2	Grease nipple $\frac{1}{8}$ " BSP
⑪	046284	1	Swivel plate, side brush

Right hand, side brush, raise/lower, top link

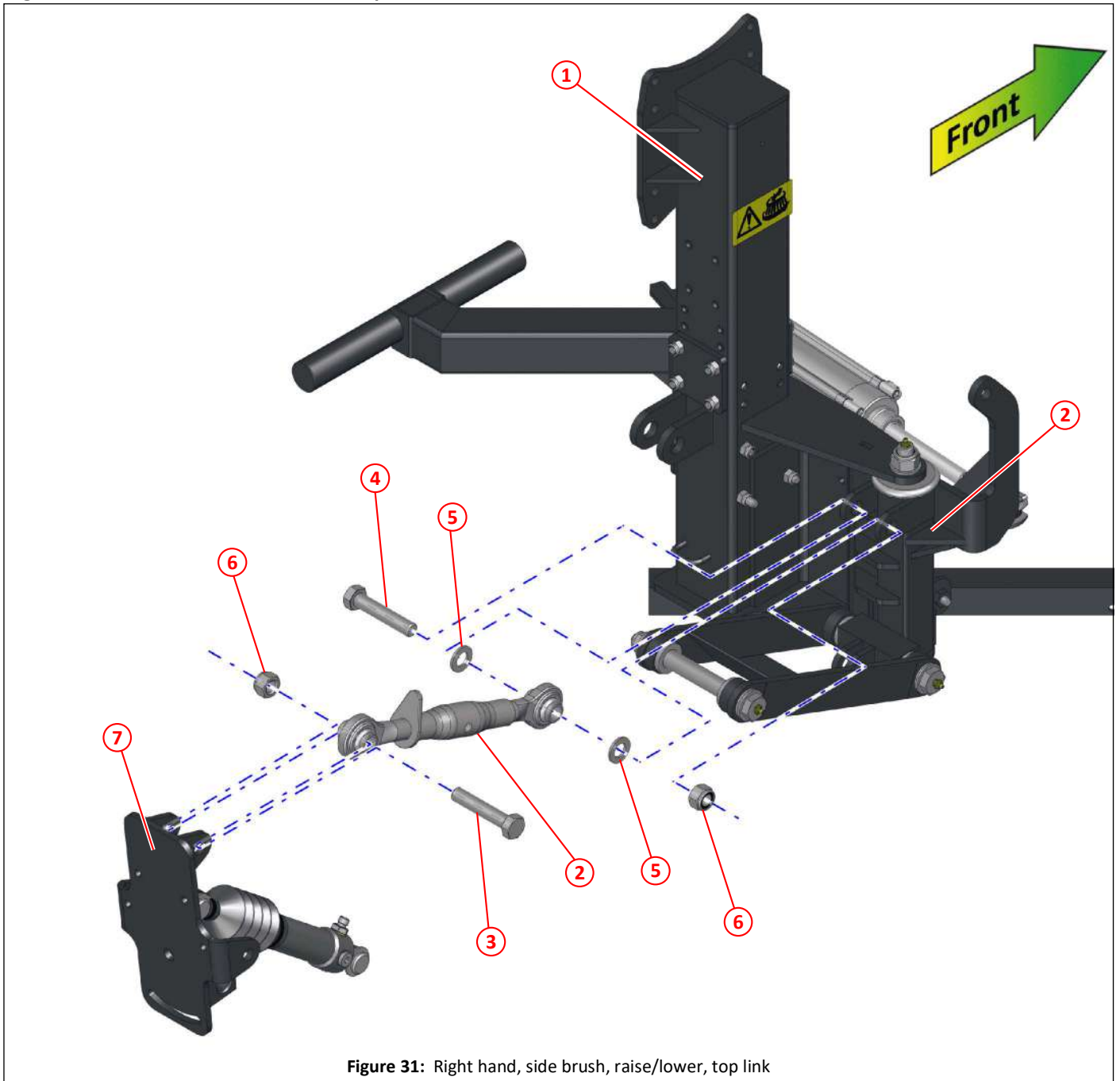

Figure 31: Right hand, side brush, raise/lower, top link

Item	Part No	Qty	Description
①	046842	1	Right hand leg
②	047025	1	King post, right hand side brush
③	013011	1	Top link (turnbuckle)
④	011140	2	Bolt M18 x 90
⑤	011138	2	Plain washer M18
⑥	011139	2	Nyloc nut T M18
⑦	046284	1	Swivel plate, side brush

Right hand, side brush, raise/lower, ram

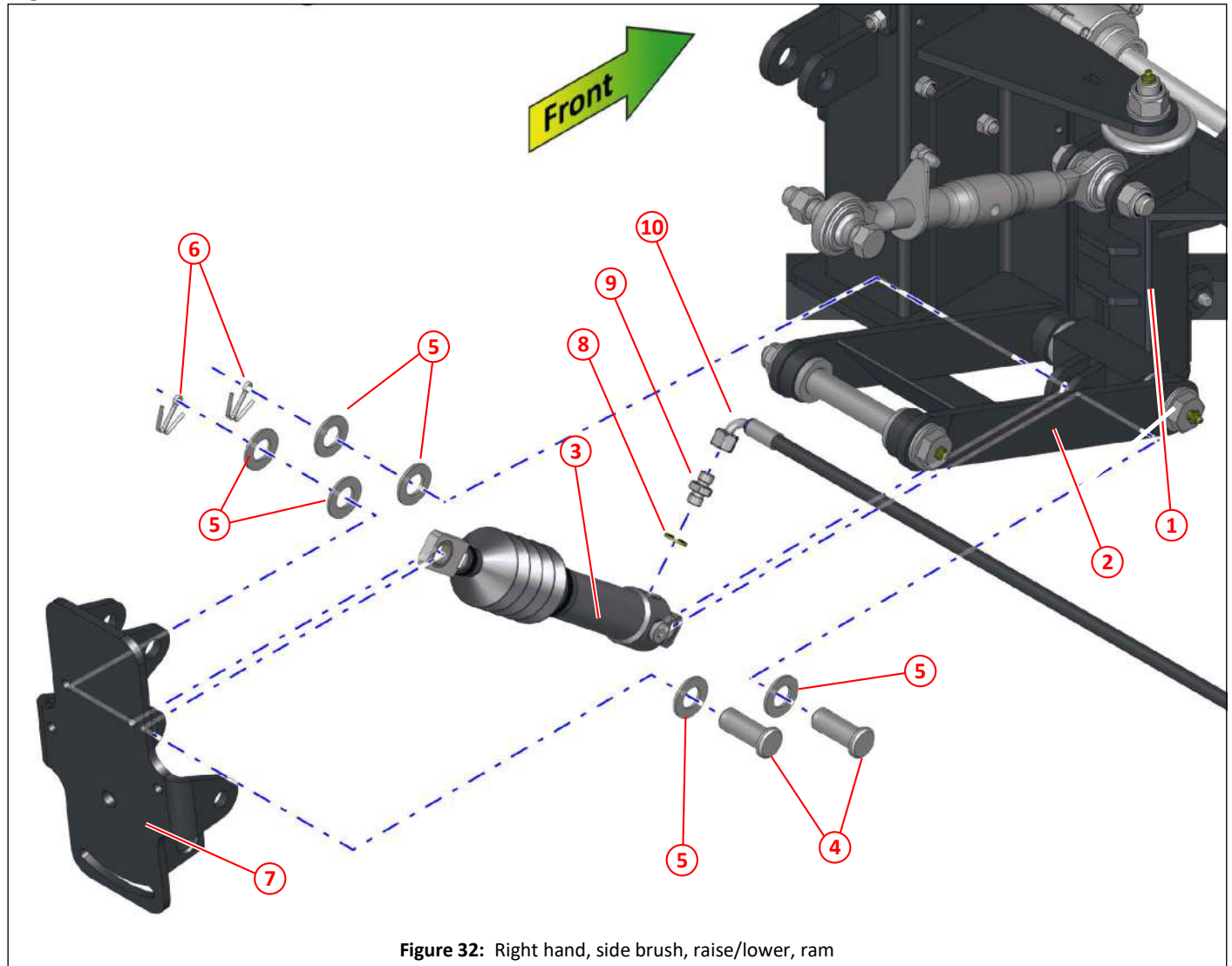

Figure 32: Right hand, side brush, raise/lower, ram

Item	Part No	Qty	Description
①	047025	1	King post, right hand side brush
②	014801	1	Brush link, side brush
③	024539	1	Ram No. 12 240/340 assembly
④	046750	2	Clevis pin, $\varnothing 20 \times 50$
⑤	011102	6	Washer, plain, M20
⑥	011122	2	Split pin, $\frac{3}{16}'' \times 1\frac{1}{2}''$
⑦	046284	1	Swivel plate, side brush
⑧	011152	1	Dowty seal $\frac{1}{4}''$ BSP
⑨	012539	1	Restrictor No 5 $\frac{1}{4}''$ BSP x $\frac{1}{4}''$ BSP $\frac{1}{32}''$ white
⑩	001371	1	Hose $\frac{1}{4}''$ BSP x 1225, straight and 90°

Right hand, side brush, raise/lower, swivel plate

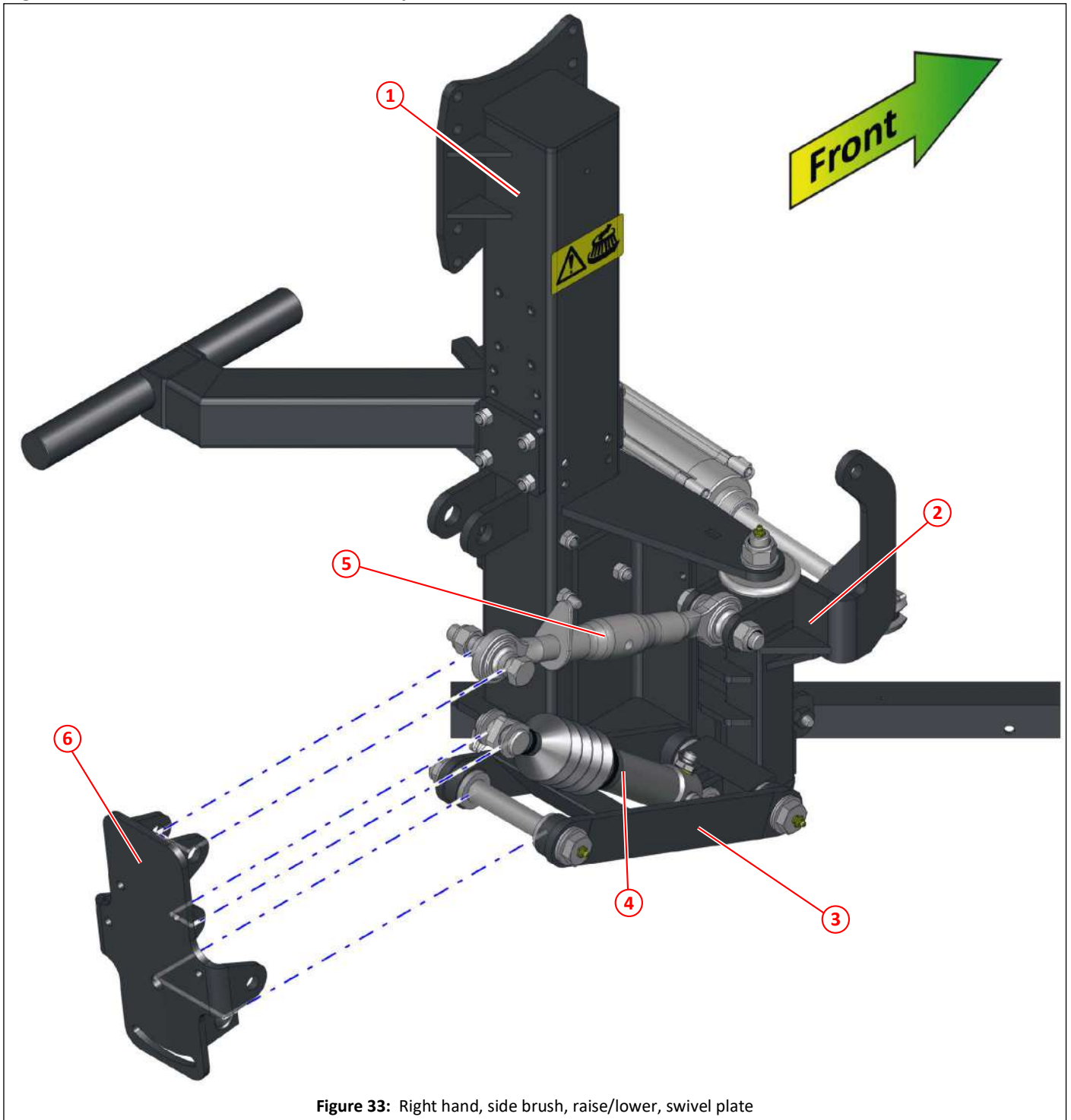

Figure 33: Right hand, side brush, raise/lower, swivel plate

Item	Part No	Qty	Description
①	046842	1	Right hand leg
②	047025	1	King post, right hand side brush
③	014801	1	Brush link, side brush
④	013011	1	Top link (turnbuckle)
⑤	024539	1	Ram No. 12 240/340 assembly
⑥	046284	1	Swivel plate, side brush

Right hand, side brush pressure

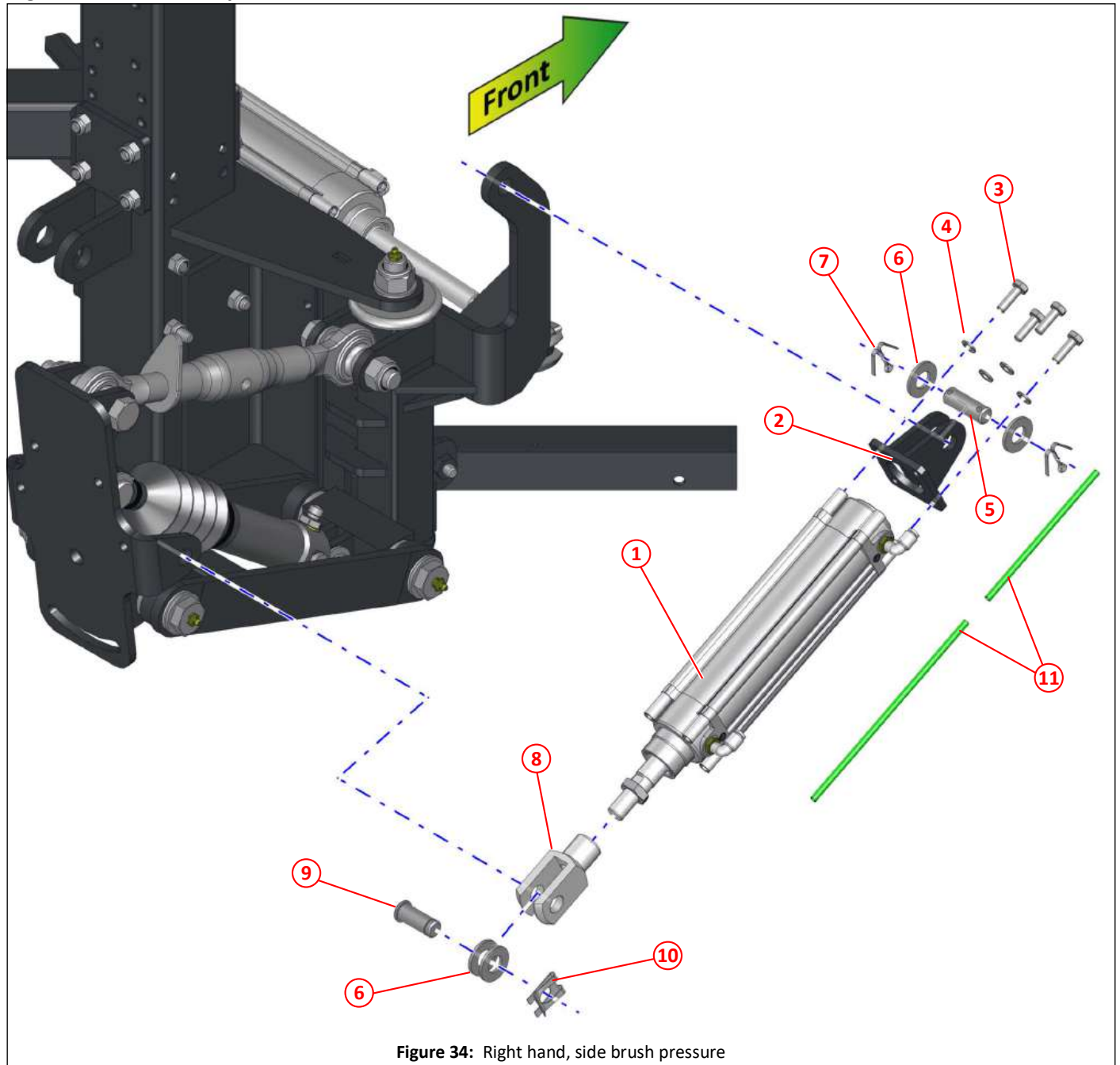

Figure 34: Right hand, side brush pressure

Item	Part No	Qty	Description
①	020298	1	Pneumatic cylinder 50 x 160
②	023122	1	Pivot, cylinder mount bracket
③	011011	4	Setscrew M8 x 25
④	011093	4	Spring washer M8
⑤	023123	1	Pin $\varnothing 16 \times 46$
⑥	011135	4	Washer, plain, M16
⑦	011122	2	Split pin, $\frac{3}{16}'' \times 1\frac{1}{2}''$
⑧	020299	1	Clevis, pneumatic, M16 x 1.5
⑨	022673	1	Clevis pin (turned)
⑩	022674	1	Retaining clip M16
⑪	024650	2	6mm green air pipe, length as required

Right hand, side brush, hose tidy

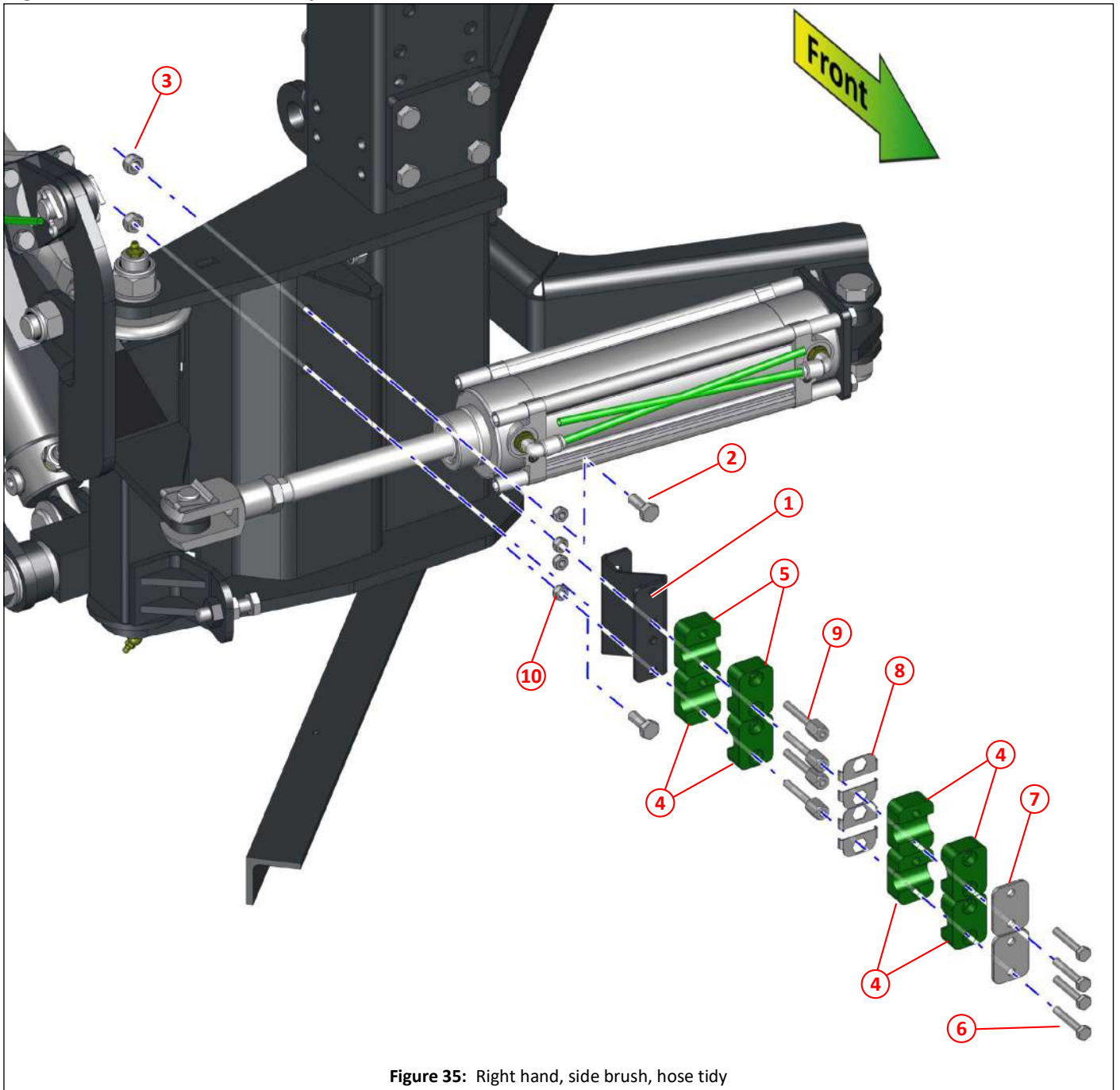

Figure 35: Right hand, side brush, hose tidy

Item	Part No	Qty	Description
①	047229	1	Right hand leg, hose tidy
②	011010	2	Set screw M8 x 20
③	011073	2	Nyloc nut T M8
④	002163	6	Pipe clamp block, 17.2 single pipe/hose
⑤	031316	2	Pipe clamp block, 1/4" single pipe/hose
⑥	011068	4	Bolt M6 x 35
⑦	031317	2	Clamp plate flat
⑧	000472	4	Locking plate SIG1
⑨	000470	4	Stacking bolt, 35mm (AF4)
⑩	011071	4	Nyloc nut T M6

Right hand, side brush skirt

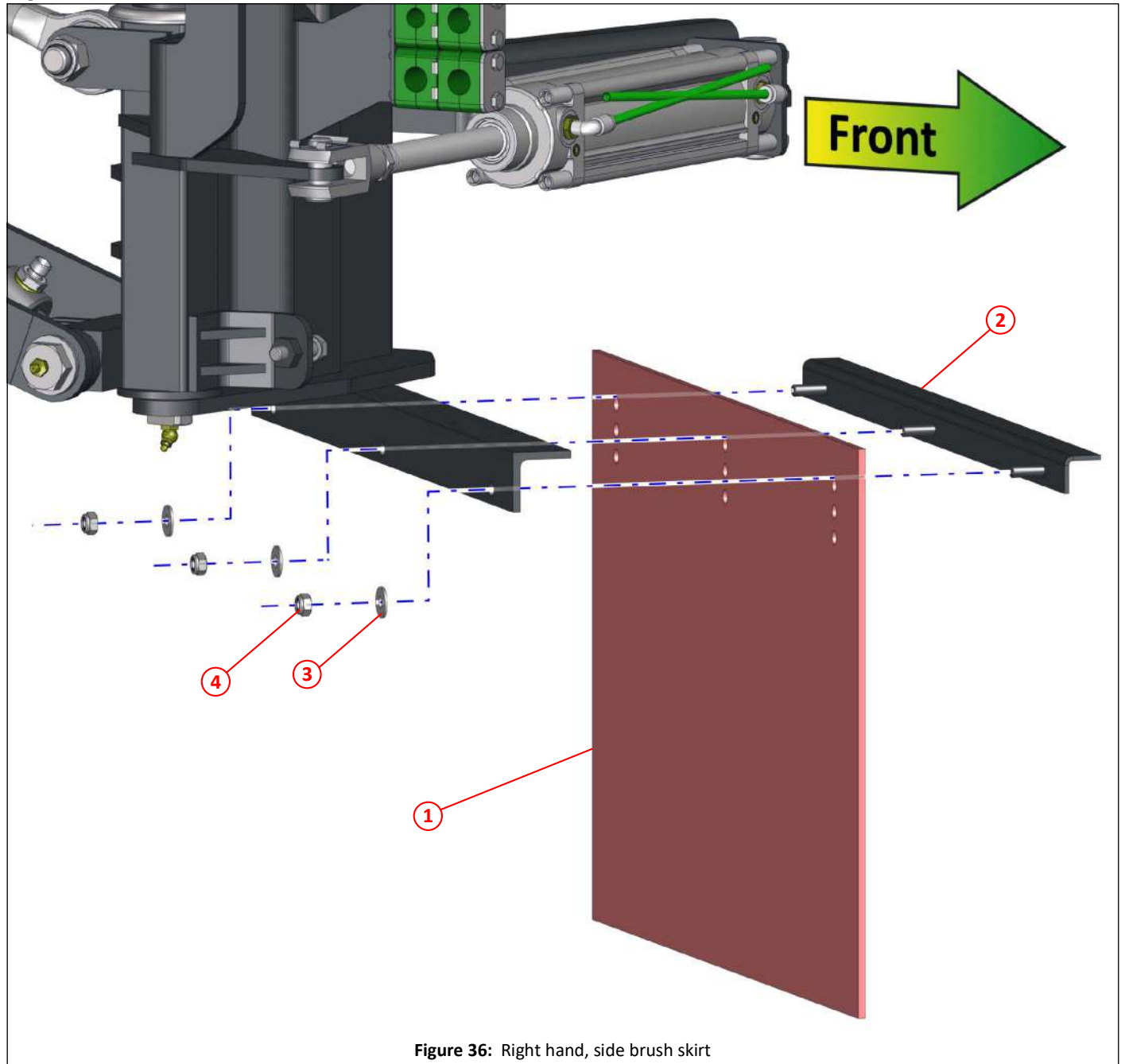
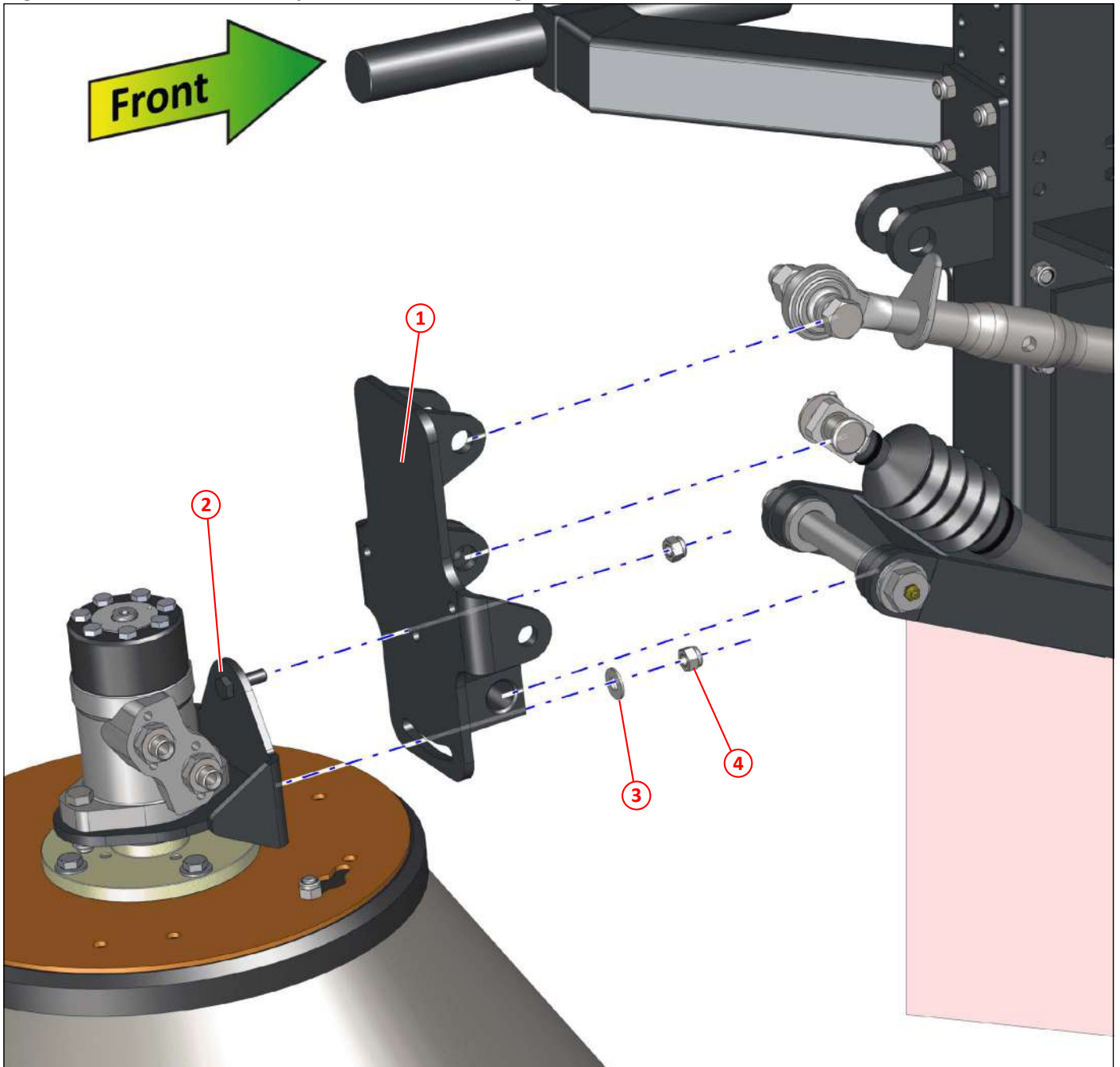

Figure 36: Right hand, side brush skirt

Item	Part No	Qty	Description
①	010247	1	Skirt, side brush, 3-pitch, heavy duty
②	010275	1	Skirt clamp
③	011092	3	Washer, plain, M8
④	011073	3	Nyloc nut T M8

Right hand, side brush, swivel plate attach (non tilting)



i Non tilting side brush is the standard fitment.

Figure 37: Right hand, side brush, swivel plate attach (non tilting)

Item	Part No	Qty	Description
①	046284	1	Swivel plate, side brush
②	010007	1	Motor bracket, side brush
③	011094	1	Washer, plain, M10
④	011075	2	Nyloc nut T M10

Right hand, side brush motor (non tilting)

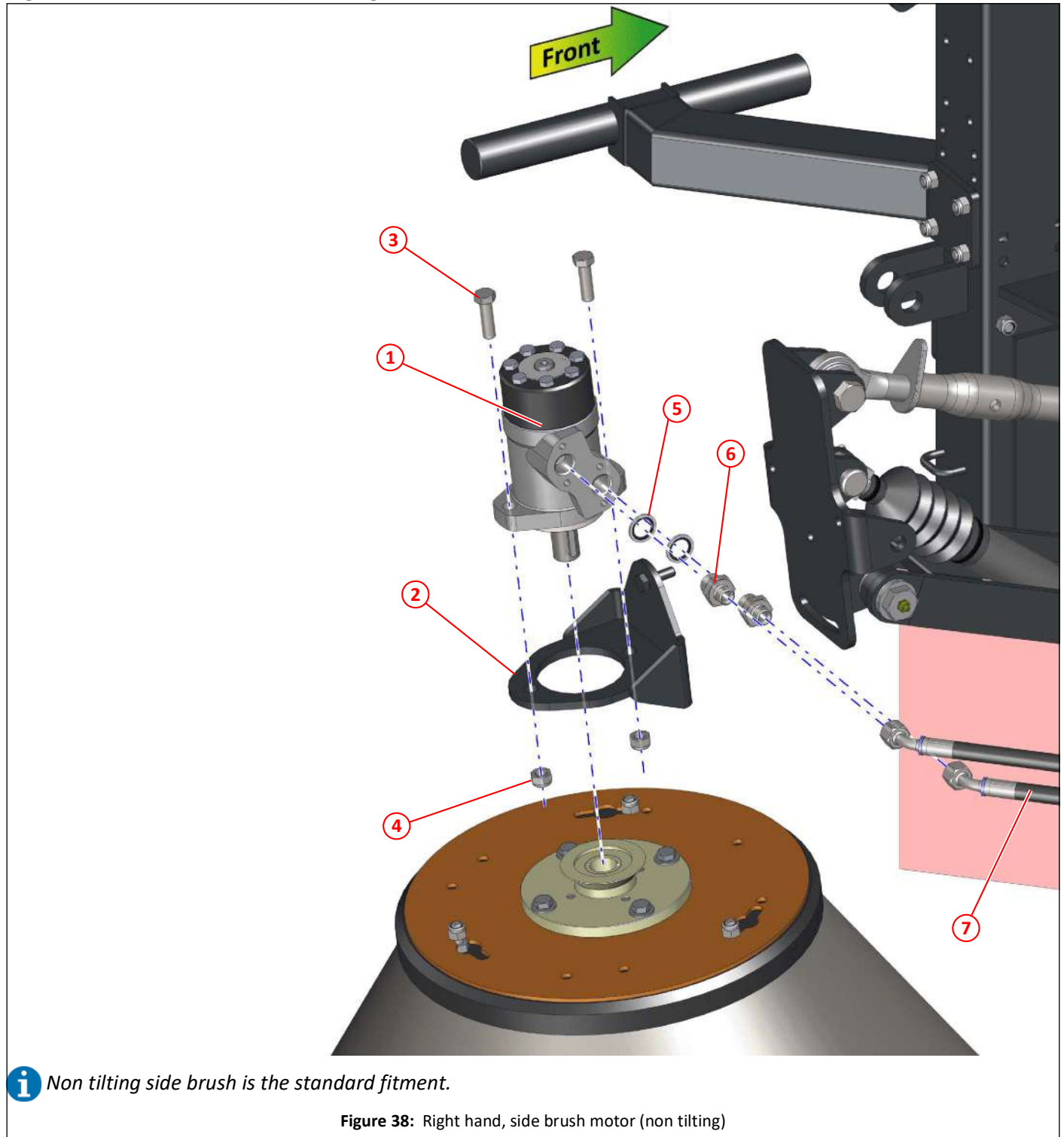

Item	Part No	Qty	Description	
①	010749	1	Motor 3597 (OMP 200)	
②	010007	1	Motor bracket, side brush	
③	011069	2	Bolt M12 x 40	
④	011077	2	Nyloc nut T M12	
⑤	011154	2	Dowty seal $\frac{1}{2}$ " BSP	
⑥	011167	2	Adapter $\frac{1}{2}$ " x $\frac{3}{8}$ " BSP	
⑦	001372	2	Hose $\frac{3}{8}$ " BSP x 1400, straight and 45°	

Right hand, side brush, swivel plate attach (tilting)

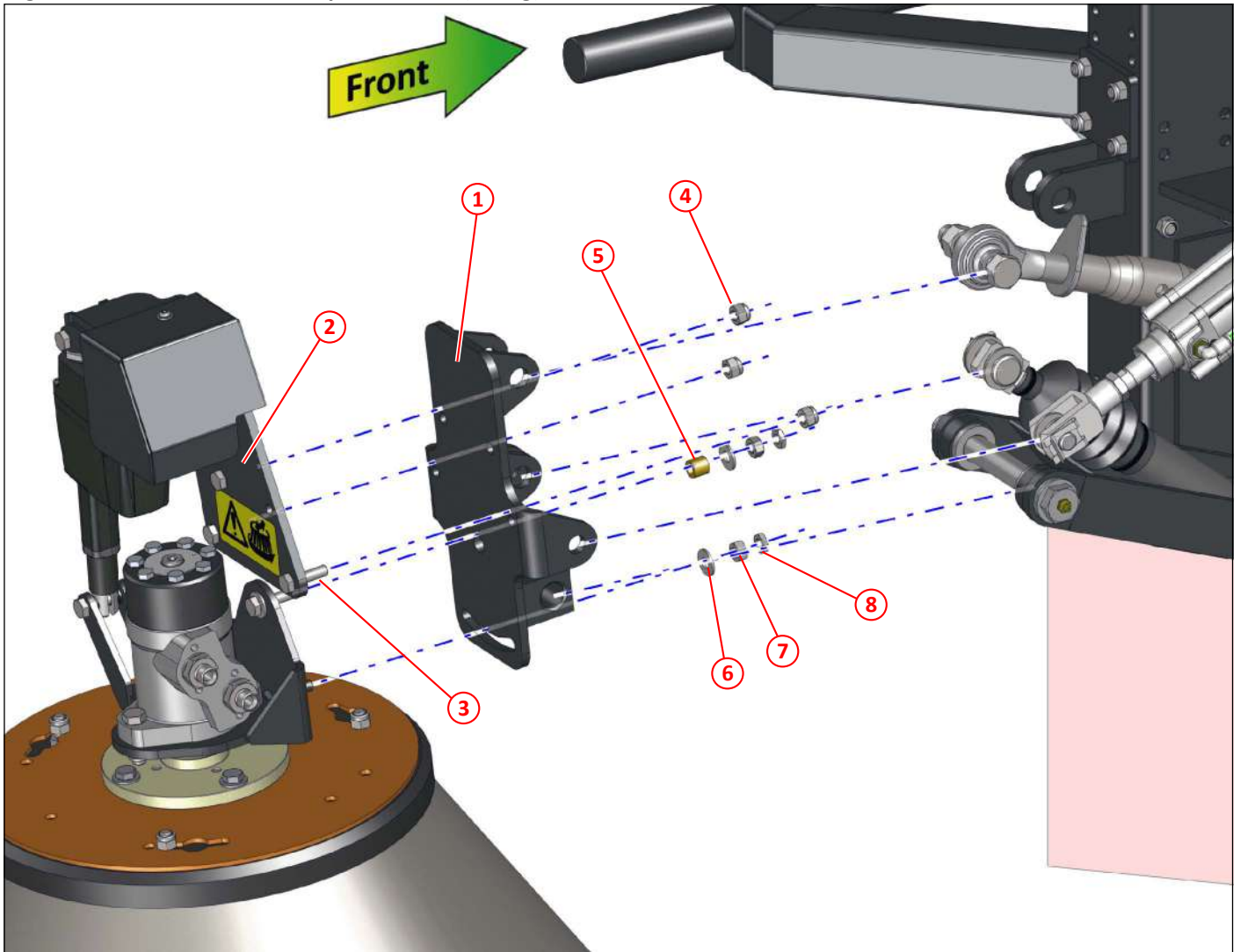

i Tilting side brush is an optional fitment.

Figure 39: Right hand, side brush, swivel plate attach (tilting)

Item	Part No	Qty	Description
①	046284	1	Swivel plate, side brush
②	046280	1	Brush tilt bracket, right hand
③	011033	4	Setscrew M10 x 35
④	011075	3	Nyloc nut T M10
⑤	046282	1	Bush 16 x 10.5 x 15
⑥	011094	2	Washer, plain, M10
⑦	011074	2	Full nut M10
⑧	000506	2	Half nut M10

Right hand, side brush tilt (tilting)

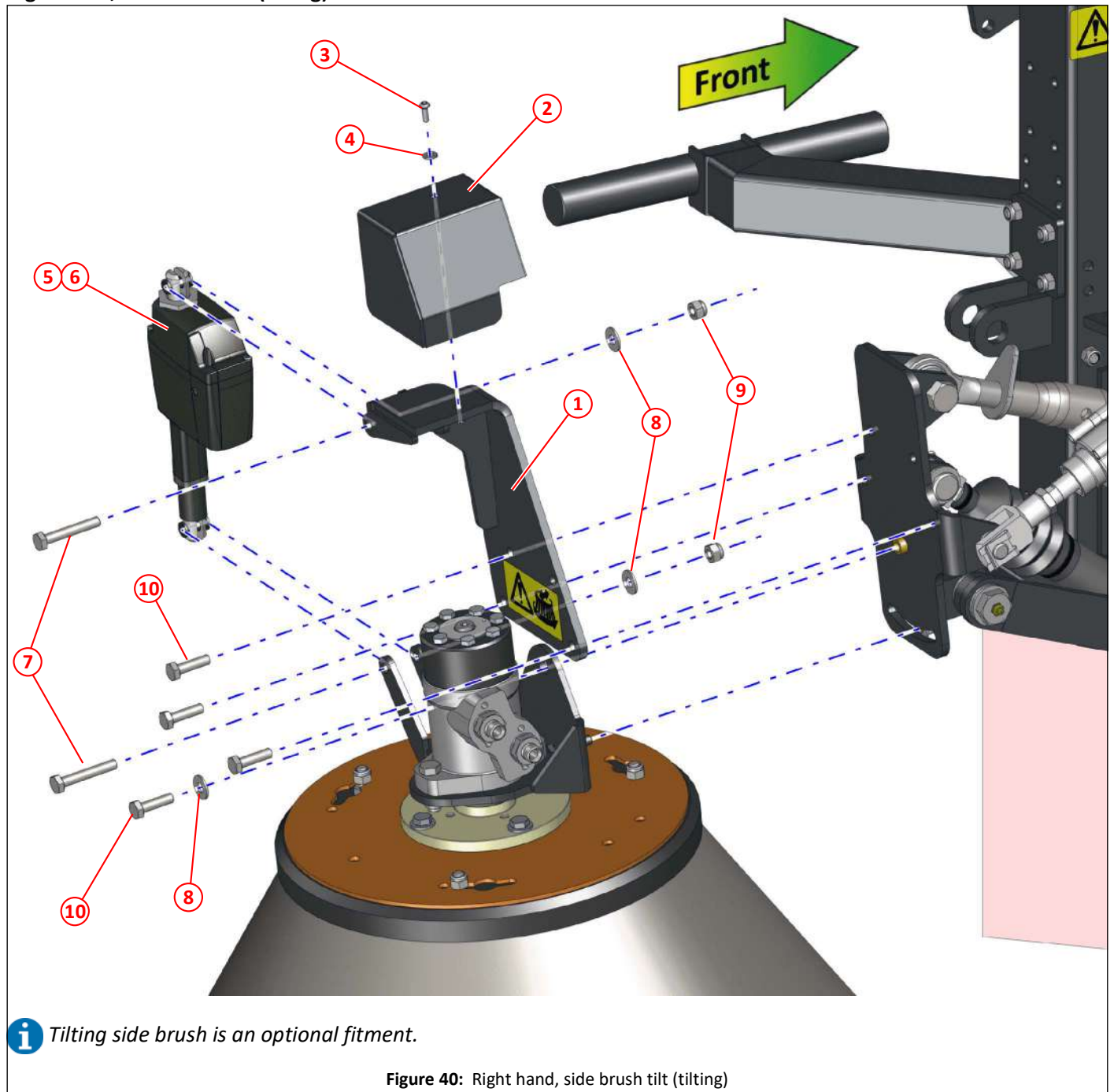

Item	Part No	Qty	Description
①	046280	1	Brush tilt bracket, right hand
②	046492	1	Actuator cover, right hand
③	000373	1	Socket dome head screw M6 x 16, stainless steel
④	000254	1	Plain washer, M6, stainless steel
⑤	046270	1	LA25/100 Actuator (12V)
⑥	047660	1	LA25/100 Actuator (24V)
⑦	011036	2	Bolt M10 x 60
⑧	011094	3	Plain washer, M10
⑨	011075	2	Nyloc nut T M10
⑩	011033	4	Setscrew M10 x 35

Right hand, side brush motor (tilting)

i Tilting side brush is an optional fitment.

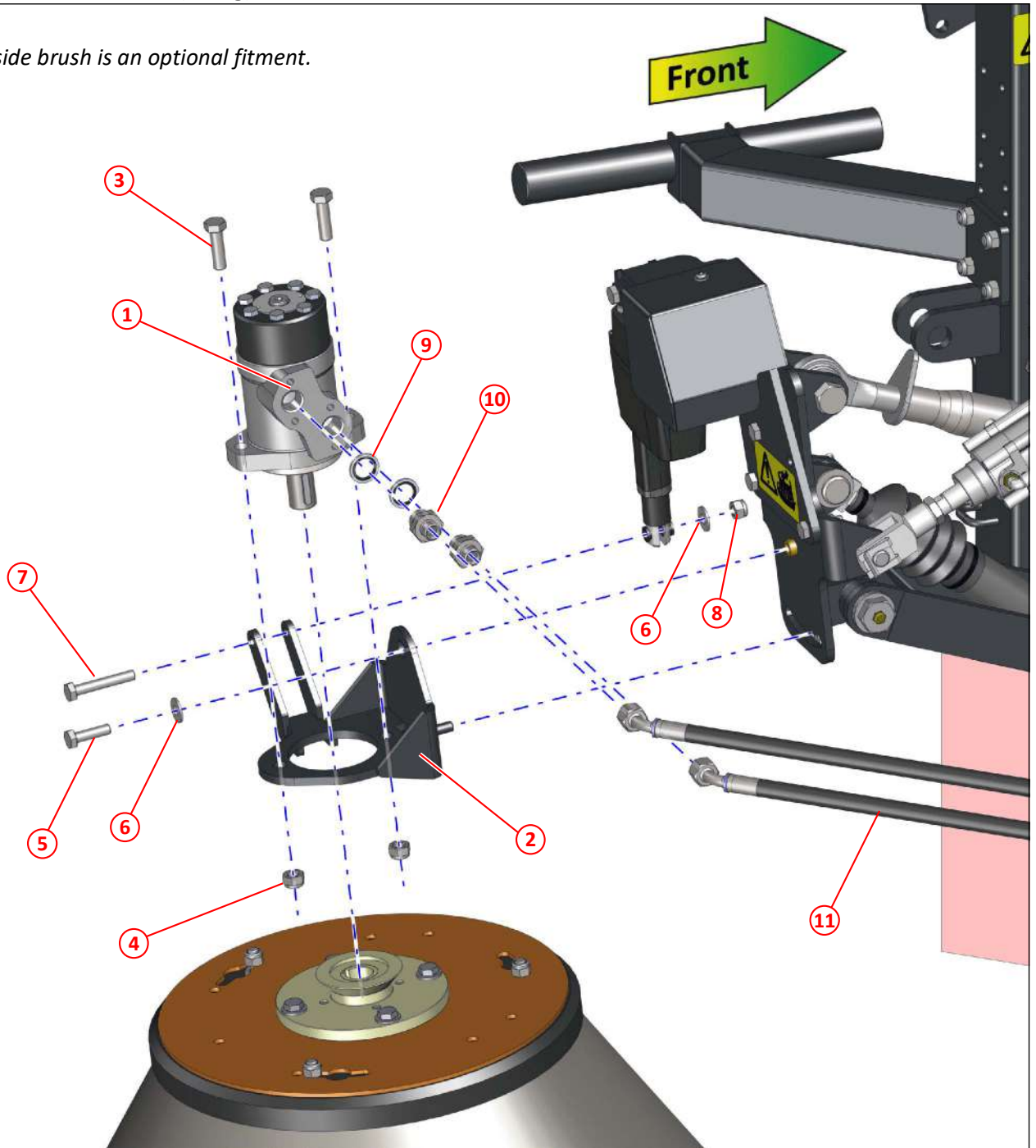

Figure 41: Right hand, side brush motor (tilting)

Item	Part No	Qty	Description
①	010749	1	Motor 3597 (OMP 200)
②	047579	1	Motor bracket tilting side brush, bolt hub, left hand
③	011069	2	Bolt M12 x 40
④	011077	2	Nyloc nut T M12
⑤	011033	1	Setscrew M10 x 35
⑥	011094	2	Plain washer, M10
⑦	011036	1	Bolt M10 x 60
⑧	011075	1	Nyloc nut T M10
⑨	011154	2	Dowty seal $\frac{1}{2}$ " BSP
⑩	011167	2	Adapter $\frac{1}{2}$ " x $\frac{3}{8}$ " BSP
⑪	001372	2	Hose $\frac{3}{8}$ " BSP x 1400, straight and 45°

Right hand, side brush hub: superseded

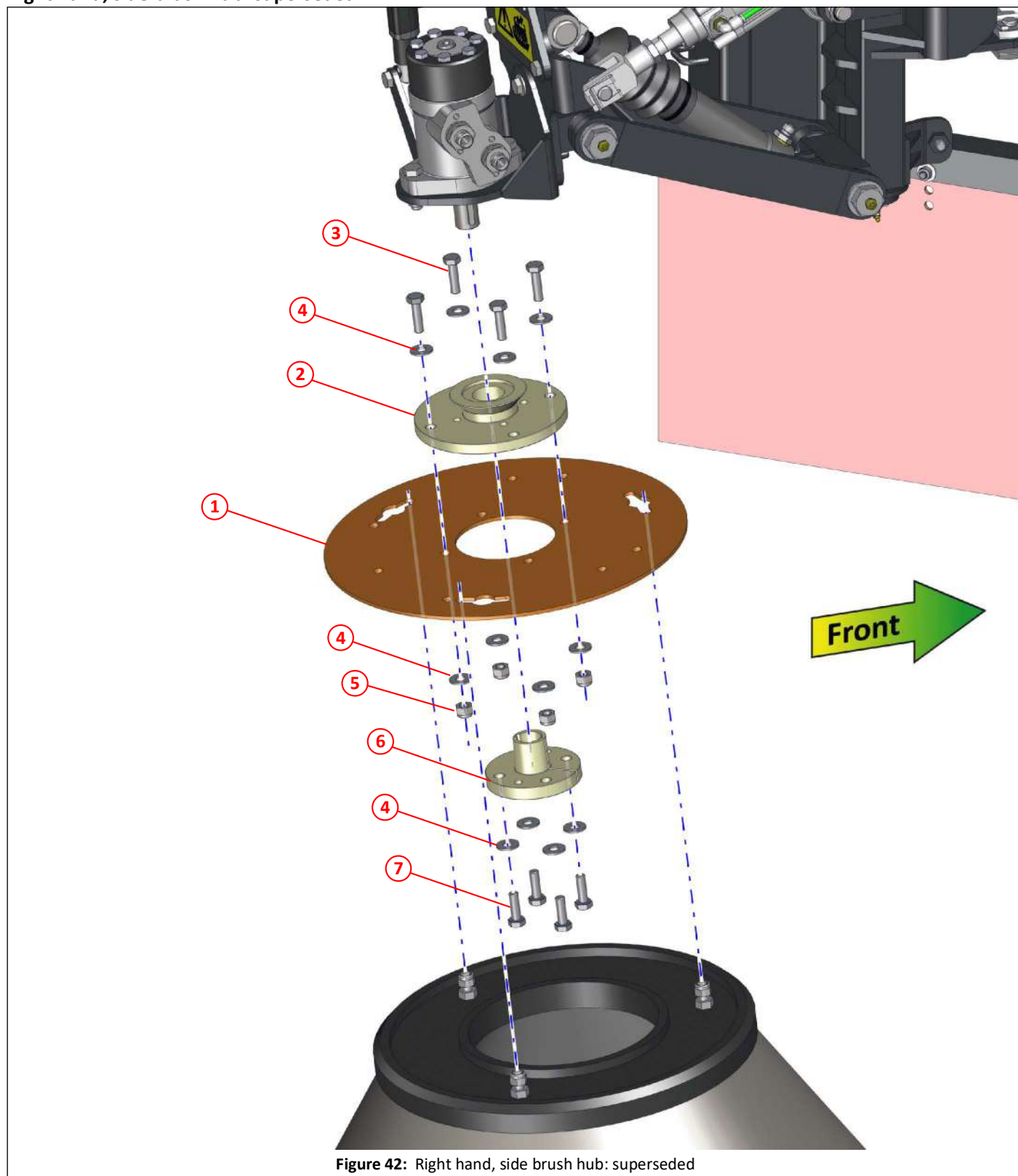

Figure 42: Right hand, side brush hub: superseded

i The above brush hub has been superseded and the parts are no longer available. See page 59 for new components to replace the above. For further information please contact the Scarab Parts Department.

Right hand, side brush hub: revised

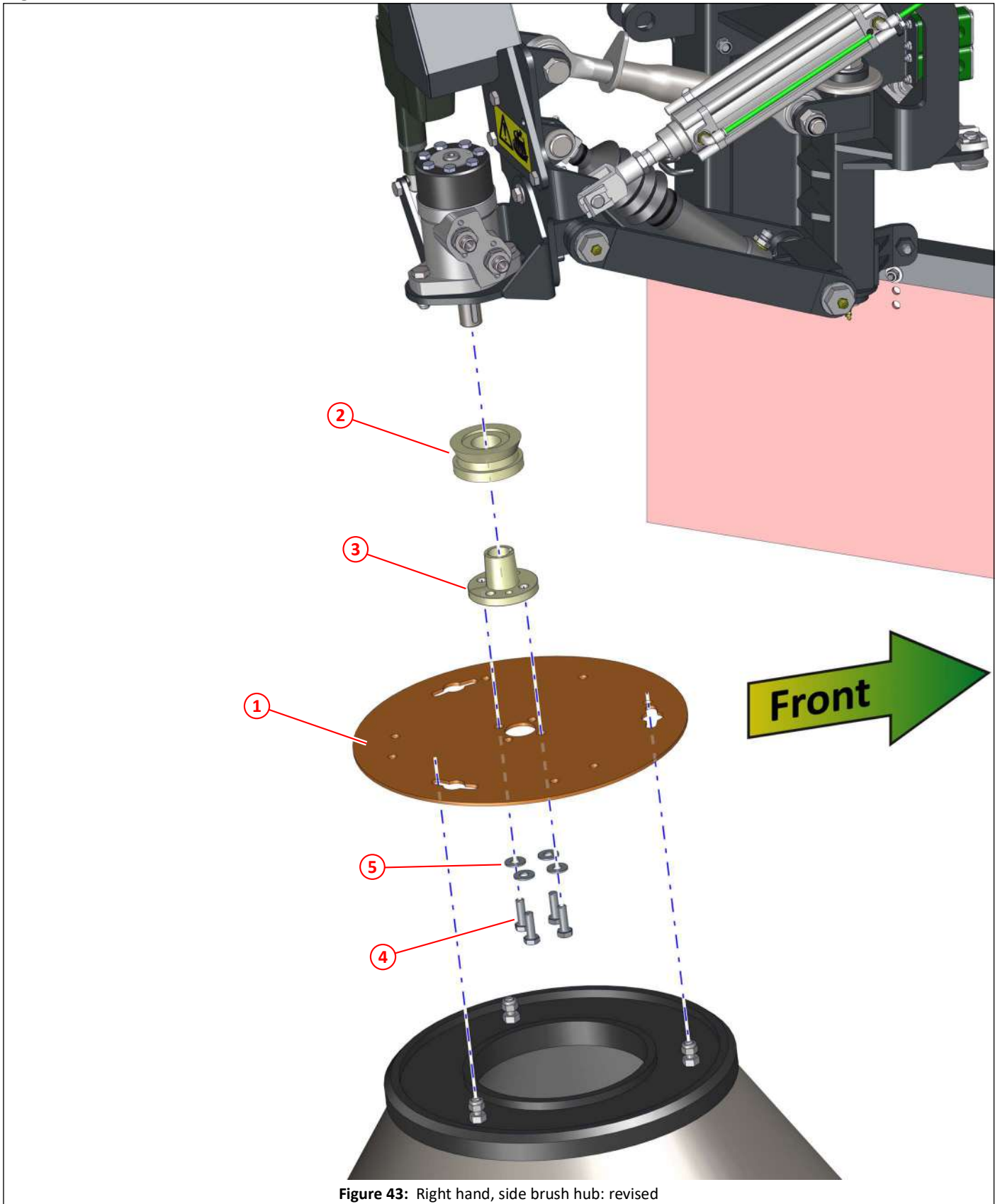

Figure 43: Right hand, side brush hub: revised

Item	Part No	Qty	Description
①	047484	1	Brush hub 7000 / side brush (bolt hub)
②	047482	1	Plate hub
③	047481	1	Sprung hub
④	000461	4	Setscrew, HT, M10 x 30, stainless steel
⑤	000270	4	Washer M10, stainless steel

Right hand, side brush, water jets mounting

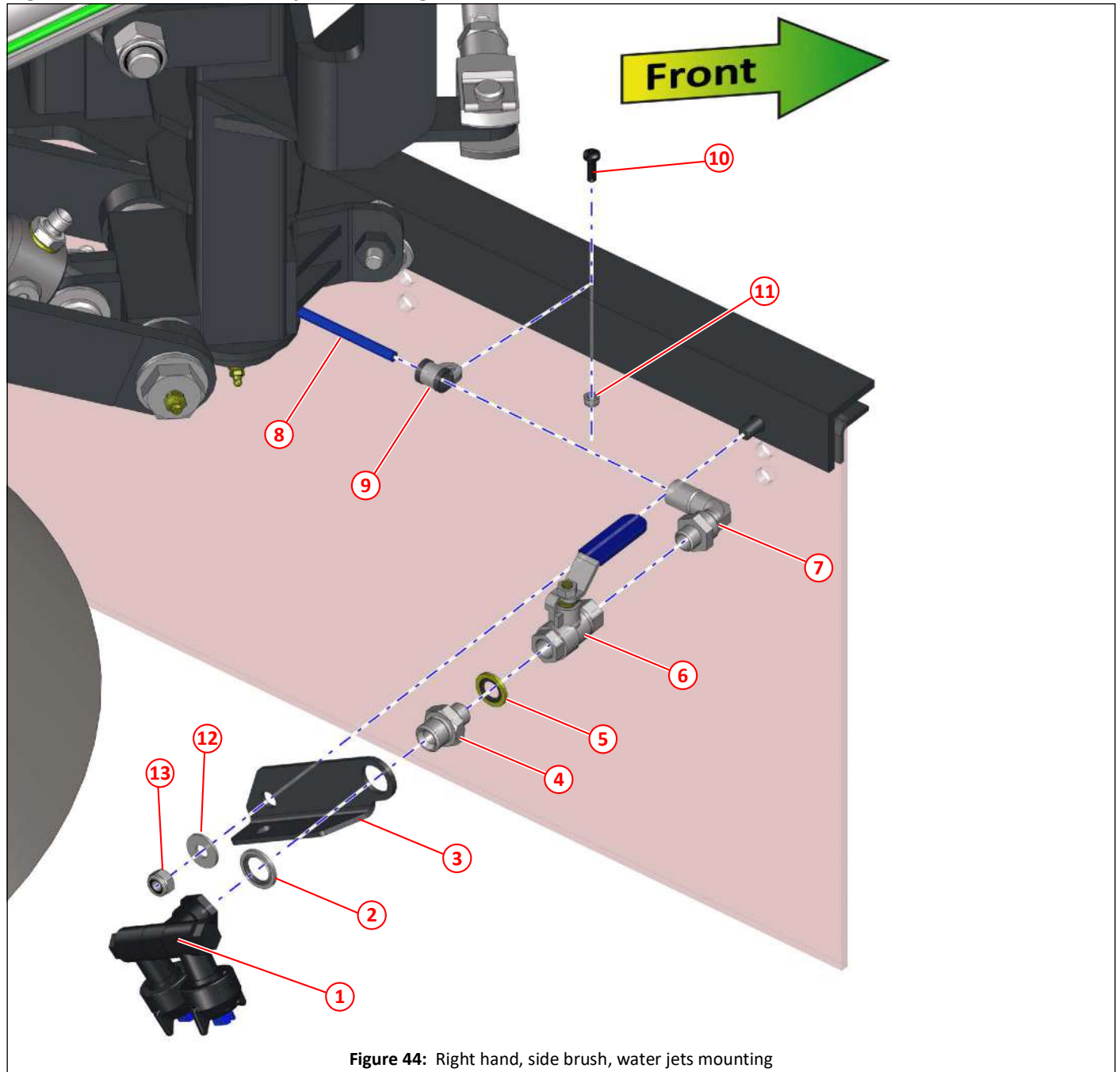

Figure 44: Right hand, side brush, water jets mounting

Item	Part No	Qty	Description
①	036044	1	Water jets, double swivel nozzle holder assembly
②	011153	1	Dowty seal $\frac{3}{8}$ " BSP
③	036043	1	Nozzle bracket, twin nozzle
④	011199	1	Adapter $\frac{3}{8}$ " BSP x $\frac{1}{4}$ " BSP
⑤	011152	1	Dowty seal $\frac{1}{4}$ " BSP
⑥	011743	1	Valve, ball, $\frac{1}{4}$ " BSP
⑦	047602	1	Adapter, angle, 90° push in 10mm x $\frac{1}{4}$ " BSP
⑧	041031	1	Blue flexible nylon tubing, \varnothing 10mm, (length as required)
⑨	021914	1	P-clip \varnothing 12mm, rubber sealed
⑩	000234	1	Setscrew, pan head pozidriv, M5 x 16, black
⑪	000155	1	Nyloc nut M5
⑫	011092	1	Plain washer M8
⑬	011073	1	Nyloc nut T M8

Dual water jets, side brush

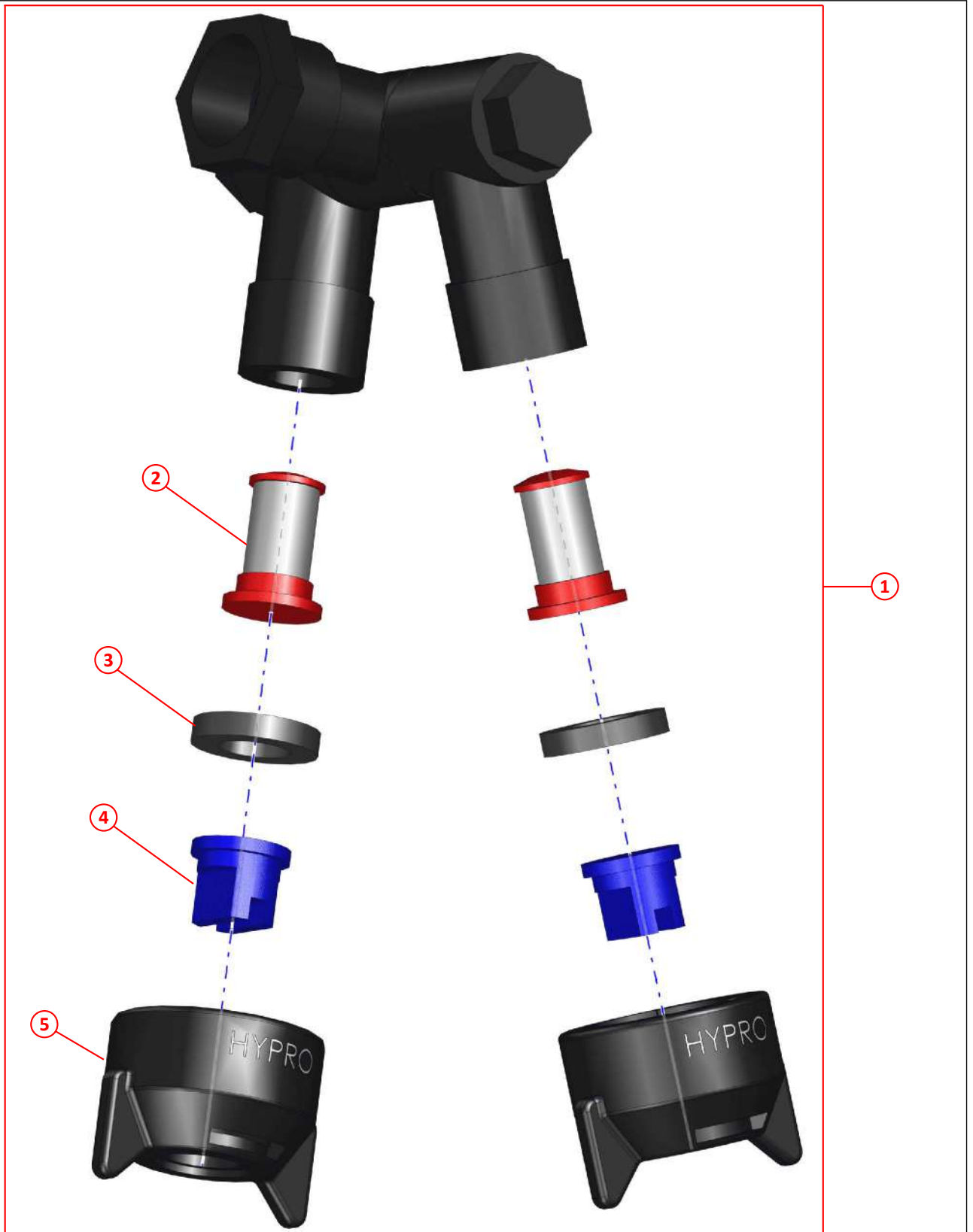

Figure 45: Dual water jets, side brush tilt

Item	Part No	Qty	Description
①	036044	1	Water jets, double swivel nozzle holder assembly
②	030633	2	Filter, 100 mesh
③	030636	2	Rubber washer
④	030748	2	Jet, blue
⑤	030746	2	Nozzle cap

Brushes, side

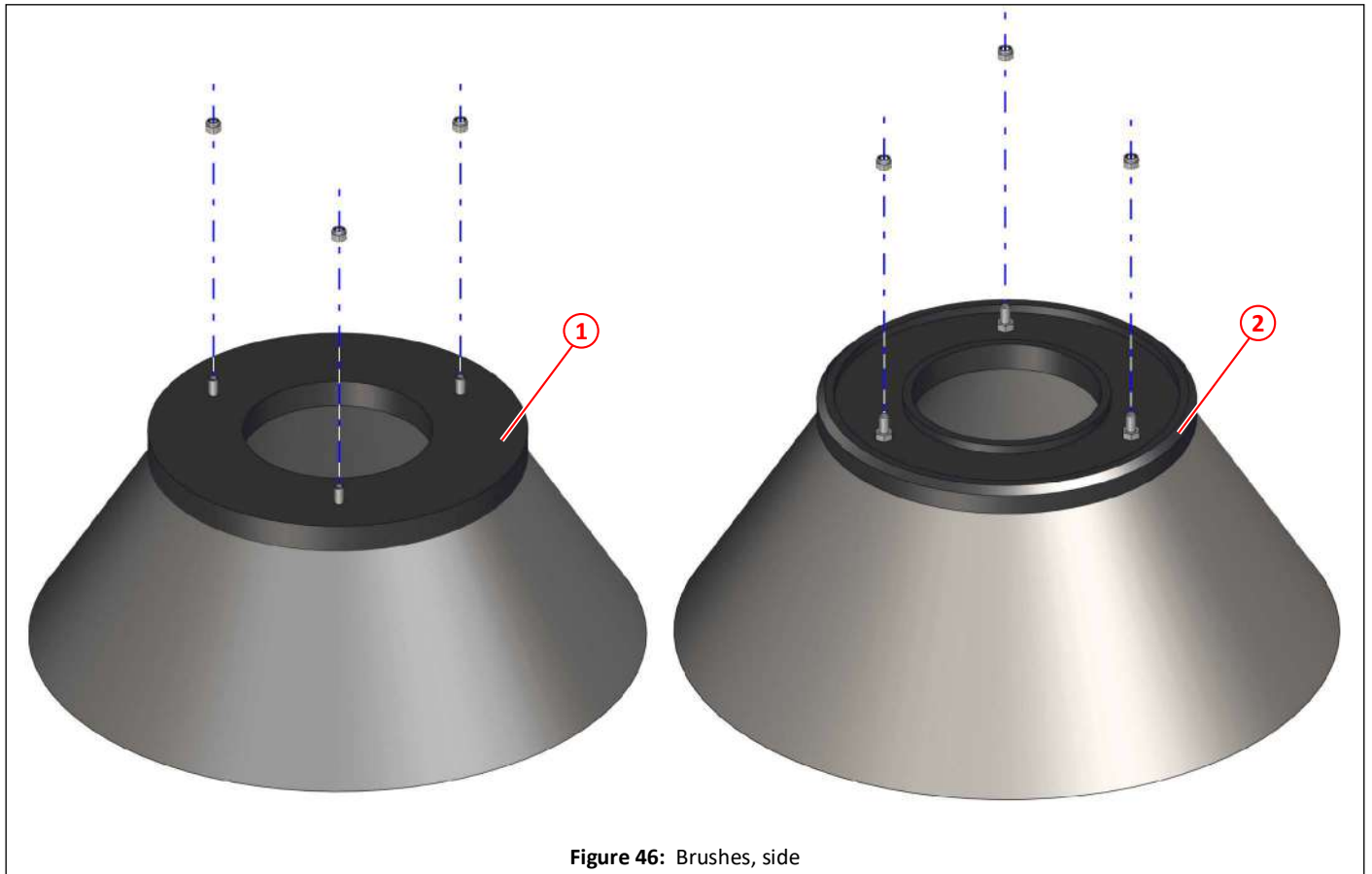

Figure 46: Brushes, side

Item	Part No	Qty	Description	
①	023473	1	Brush, side $\phi 400 - \phi 650$ steel	
②	040136	1	Brush, side $\phi 400 - \phi 700$ steel	

Central brush (wide sweep) arrangement

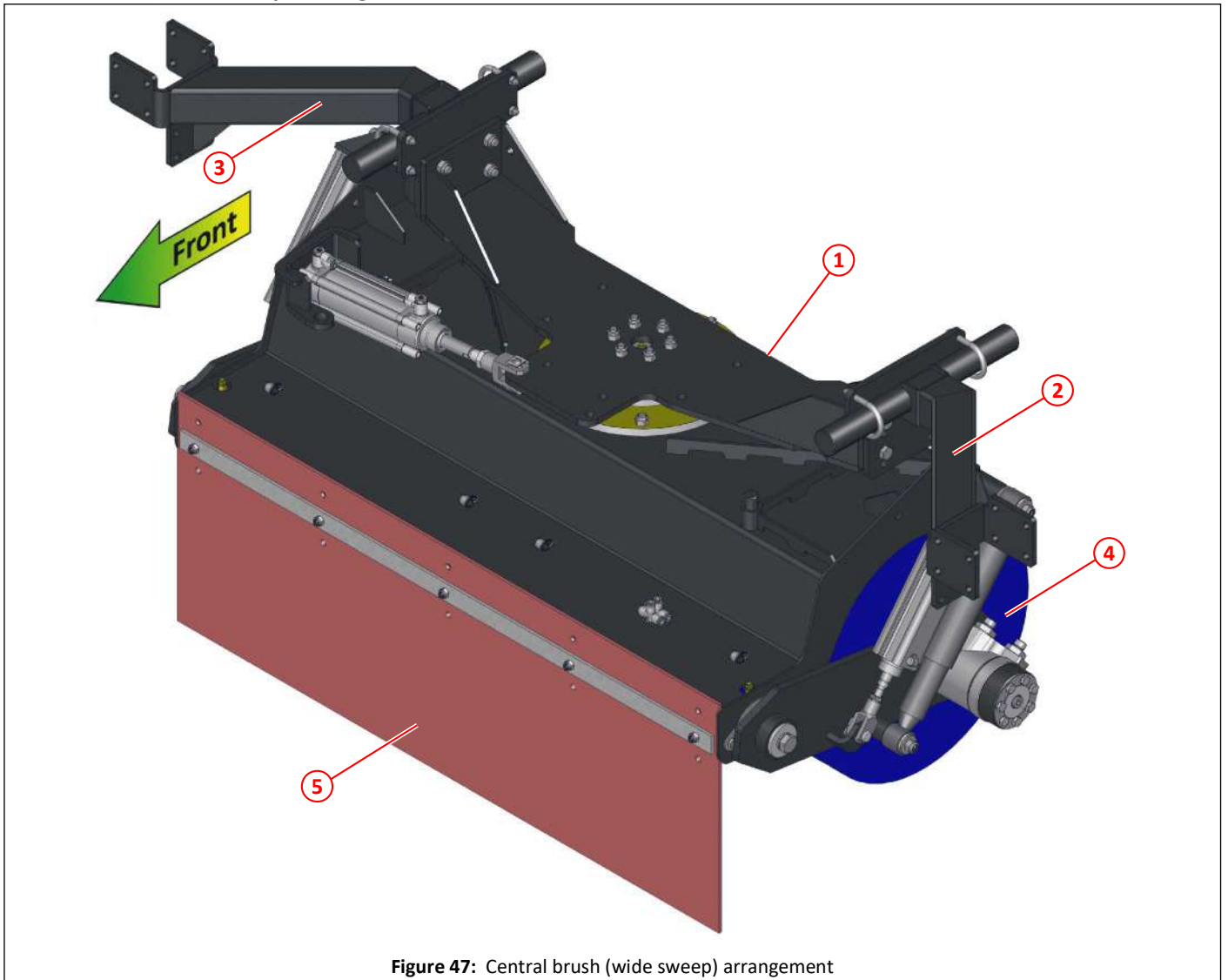

Figure 47: Central brush (wide sweep) arrangement

Item	Part No	Qty	Description	
①	037316	1	Central brush (wide sweep) assembly	
②	034334	1	Central brush (wide sweep) adjustabar left hand	64
③	034335	1	Central brush (wide sweep) adjustabar right hand	64
④	037588	1	Brush assembly, central brush (wide sweep)	83
⑤	022516	1	Skirt, central brush (wide sweep)	69

Central brush (wide sweep) mounting

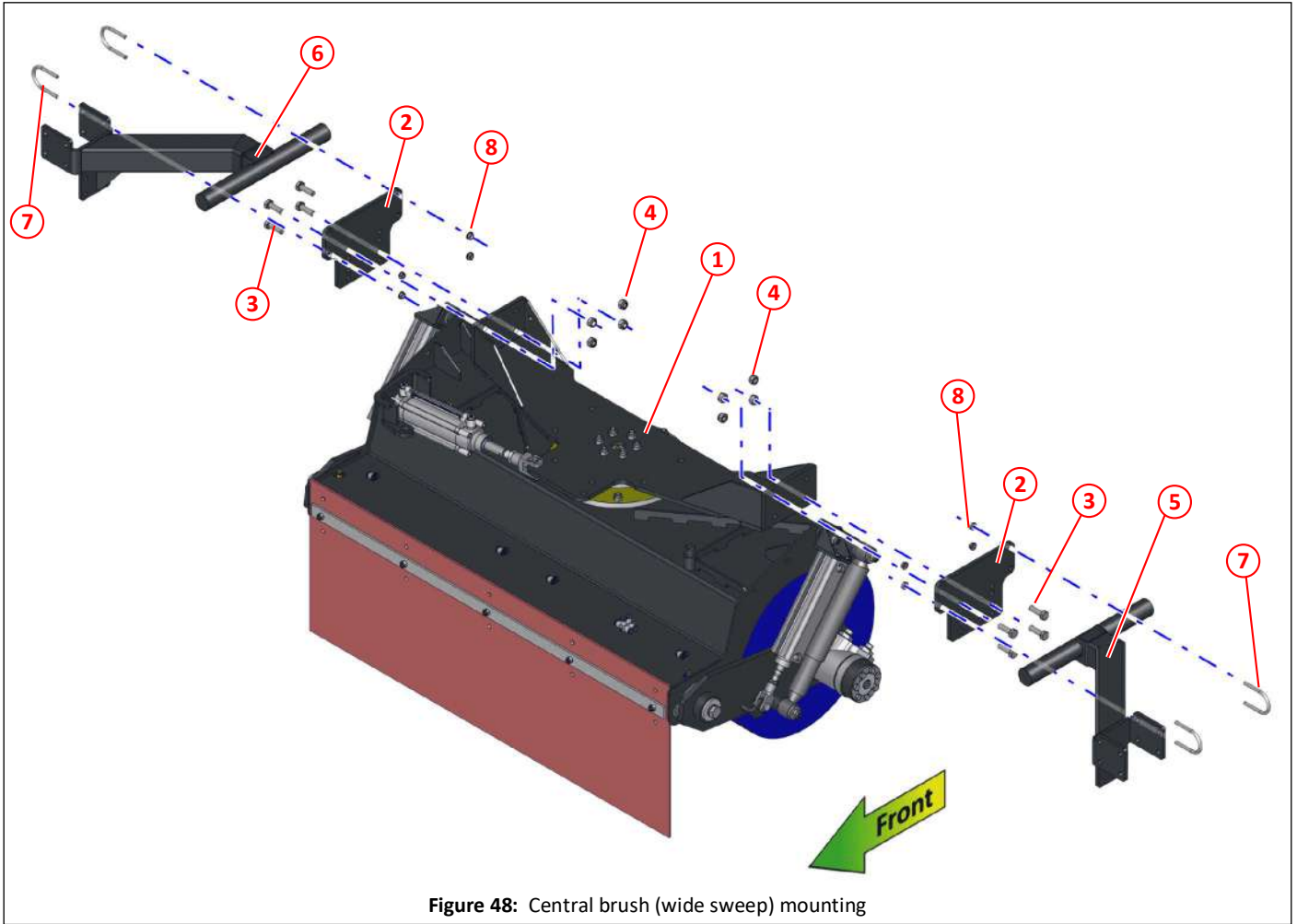

Figure 48: Central brush (wide sweep) mounting

Item	Part No	Qty	Description	
①	037316	1	Central brush (wide sweep) assembly	
②	034336	2	Central brush (wide sweep) drop plate	
③	011053	8	Setscrew M12 x 35	
④	011077	8	Nyloc nut T M12	
⑤	034334	1	Central brush (wide sweep) adjustabar left hand	
⑥	034335	1	Central brush (wide sweep) adjustabar right hand	
⑦	014983	4	'U' clamp 1 ⁵ / ₈ "	
⑧	000185	8	Nut M8, plain faced flange, plated	

Central brush (wide sweep) support - fixed slew

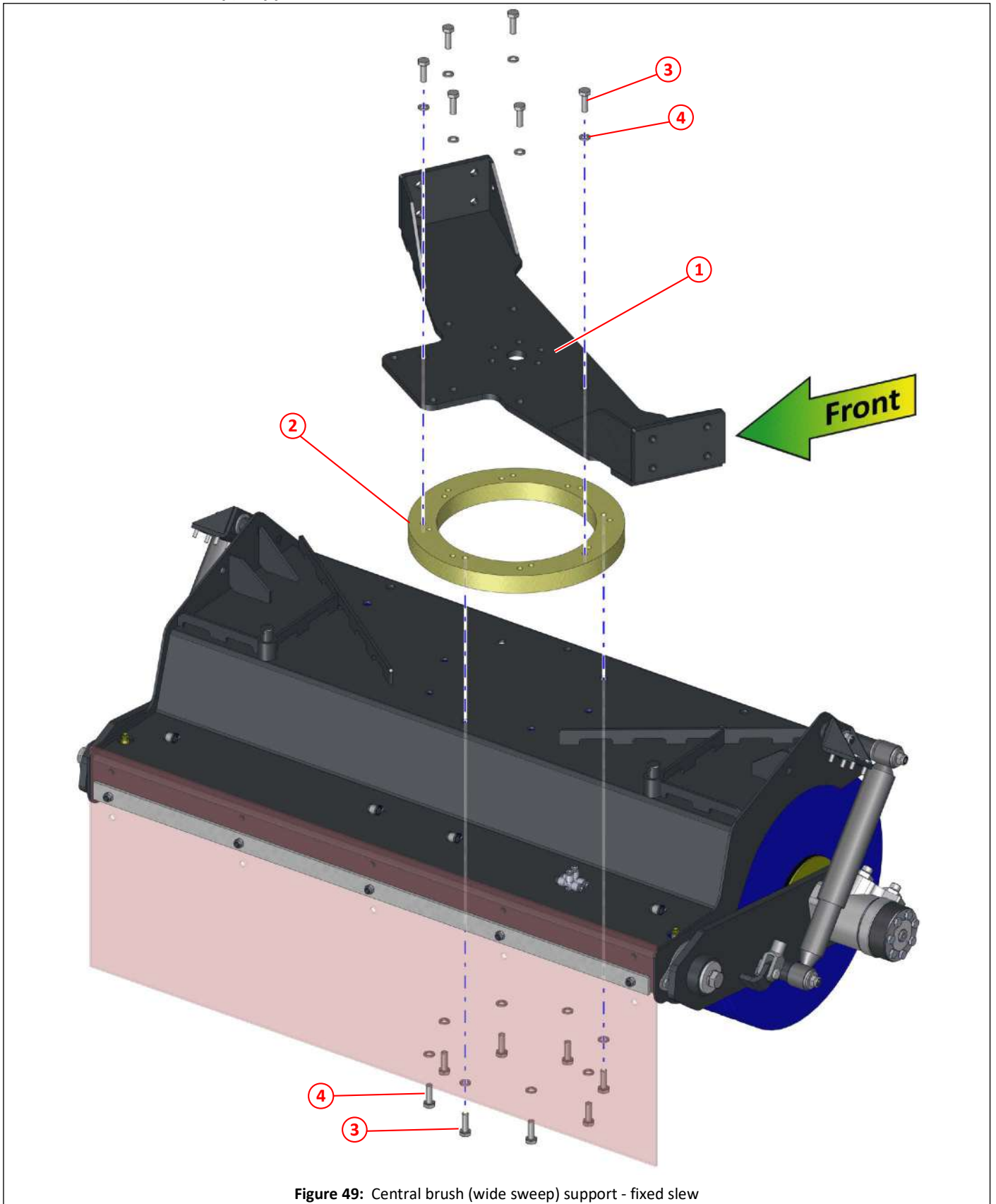

Figure 49: Central brush (wide sweep) support - fixed slew

Item	Part No	Qty	Description
①	024155	1	Central brush (wide sweep) support bracket
②	020919	1	Central brush (wide sweep) adapter ring, fixed slew
③	011032	14	Setscrew M10 x 30
④	011095	14	Spring washer M10

Central brush (wide sweep) support slewing

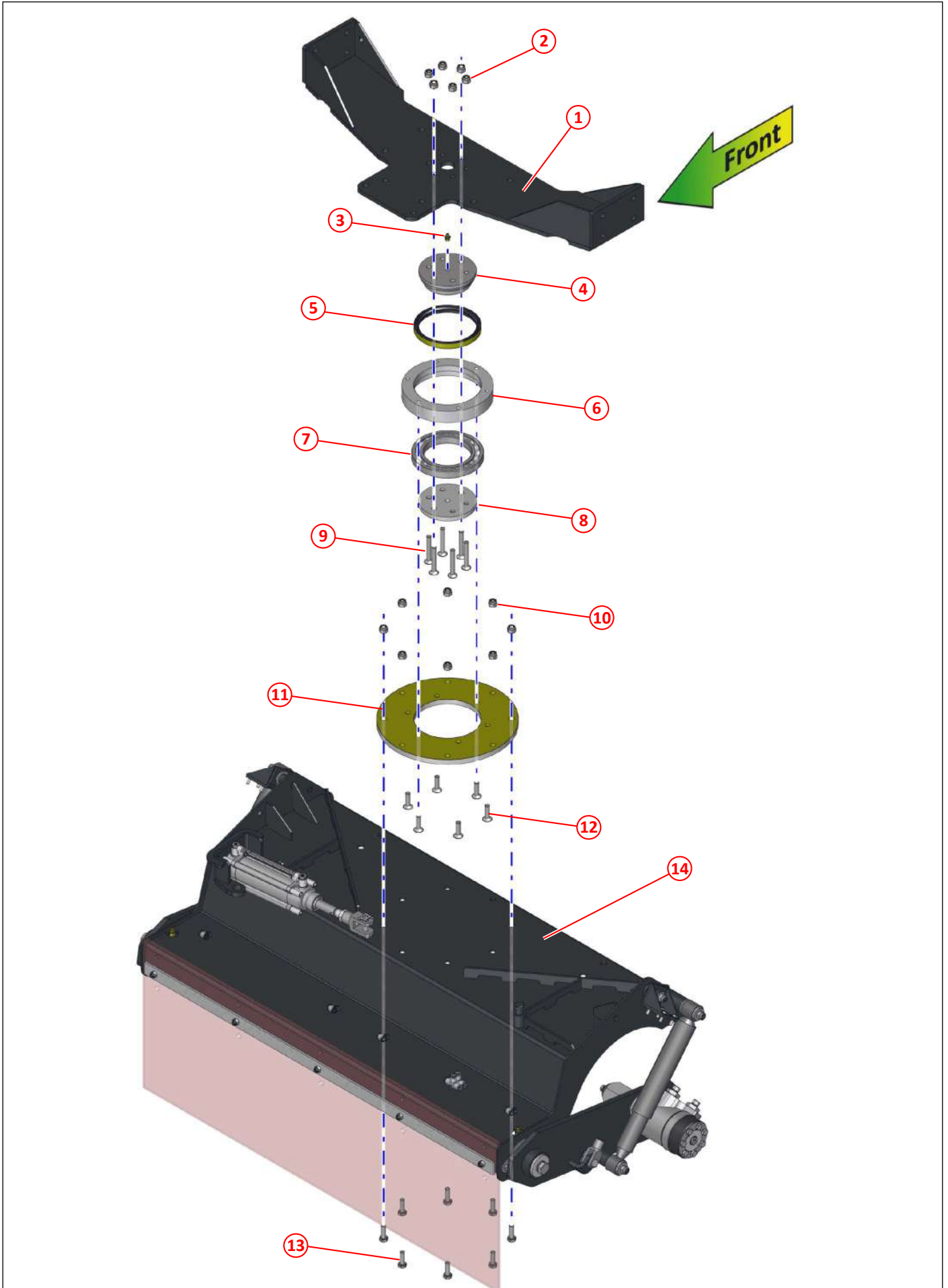

Figure 50: Central brush (wide sweep) support slewing

Item	Part No	Qty	Description	
①	024155	1	Central brush (wide sweep) support bracket	
②	011075	6	Nyloc nut T M10	
③	010903	1	Grease nipple $\frac{1}{8}$ " BSP straight	
④	024150	1	Spigot	
⑤	024148	1	Oil seal 120 x 140 x 13	
⑥	024152	1	Bearing housing	
⑦	024149	1	Bearing, ball 100 x 150 x 16 (16020)	
⑧	024151	1	Clamp plate	
⑨	000183	6	Screw, countersunk, socket head M10 x 65	
⑩	011075	8	Nyloc nut T M10	
⑪	024154	1	Clamp ring	
⑫	000546	6	Screw, countersunk, M10 x 35	
⑬	011032	8	Setscrew M10 x 30	
⑭	036216	1	Central brush (wide sweep) cover	

Central brush (wide sweep) slewing ram

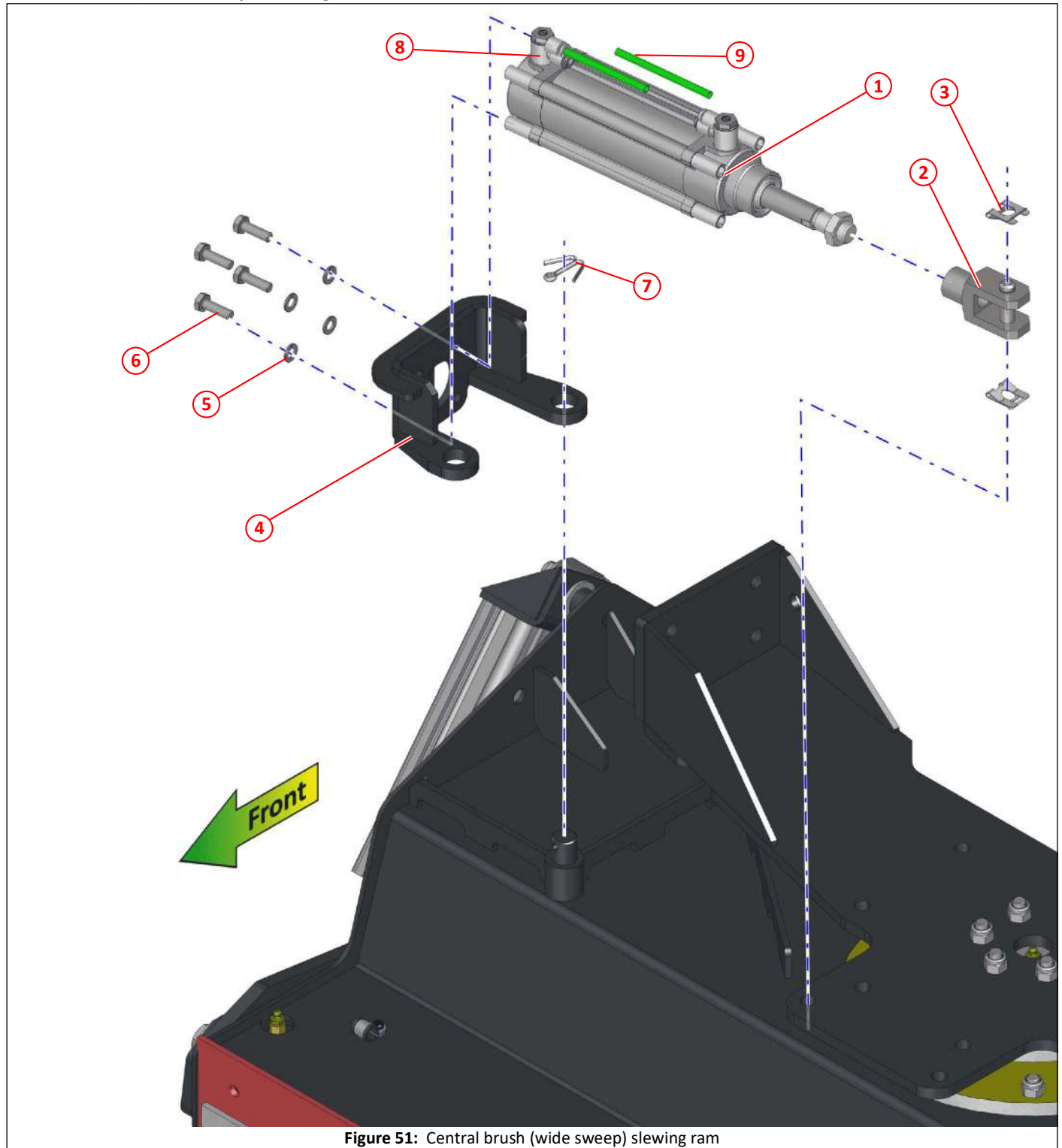

Figure 51: Central brush (wide sweep) slewing ram

Item	Part No	Qty	Description
①	020767	1	Pneumatic cylinder $\phi 50 \times 100$
②	036621	1	Clevis special M16 neck with $\phi 12$ PIN
③	023269	2	Safety fastener $\phi 12$
④	036620	1	Mounting bracket for pneumatic cylinder, slewing central brush (wide sweep)
⑤	011093	4	Spring washer M8
⑥	011011	4	Setscrew M8 x 25
⑦	011122	2	Split pin, $\frac{3}{16}$ " x $1\frac{1}{2}$ "
⑧	021158	2	Pneumatic flow regulator
⑨	024650	2	6mm green air pipe, length as required

Central brush (wide sweep) skirt

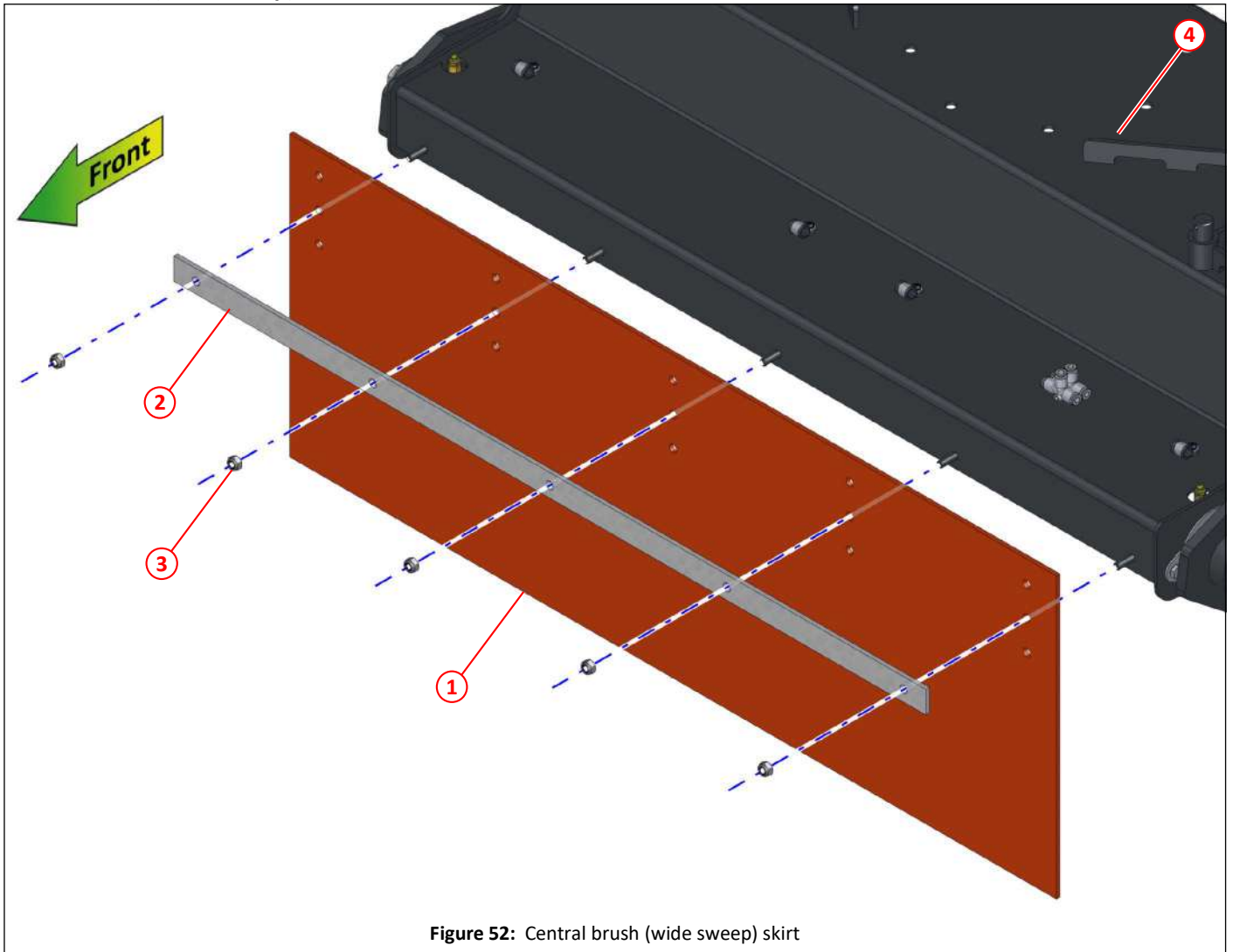

Figure 52: Central brush (wide sweep) skirt

Item	Part No	Qty	Description
①	022516	1	Skirt, central brush
②	022517	1	Clamp, central brush skirt
③	011073	5	Nyloc nut T M8
④	036216	1	Cover, central brush (wide sweep)

Central brush (wide sweep) LH raise lower ram

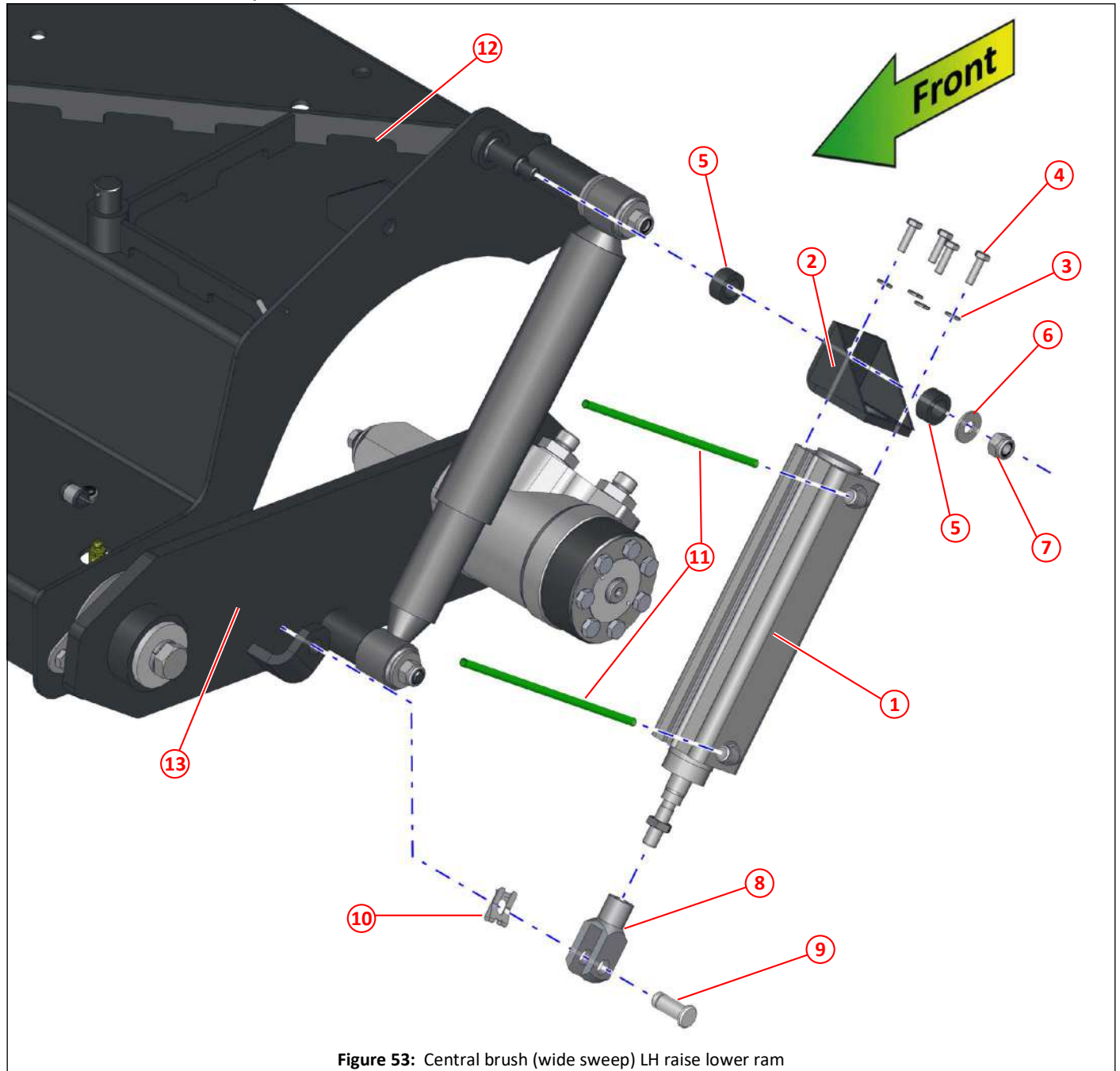

Figure 53: Central brush (wide sweep) LH raise lower ram

Item	Part No	Qty	Description
①	020602	1	Pneumatic cylinder $\phi 40 \times 125$
②	030532	1	Air ram mounting bracket, central brush
③	011091	4	Spring washer M6
④	011067	4	Setscrew M6 x 20
⑤	011000	2	Hose $\frac{5}{8}$ " , fuel SAE100R6, cut to 11mm
⑥	011094	1	Plain washer M10
⑦	011075	1	Nyloc nut T M10
⑧	014469	1	Clevis M12
⑨	023270	1	Clevis pin $\phi 12$
⑩	023269	1	Safety fastener $\phi 12$
⑪	024650	2	6mm green air pipe, length as required
⑫	036216	1	Cover, central brush (wide sweep)
⑬	023077	1	Motor plate LH

Central brush (wide sweep) LH shock absorber

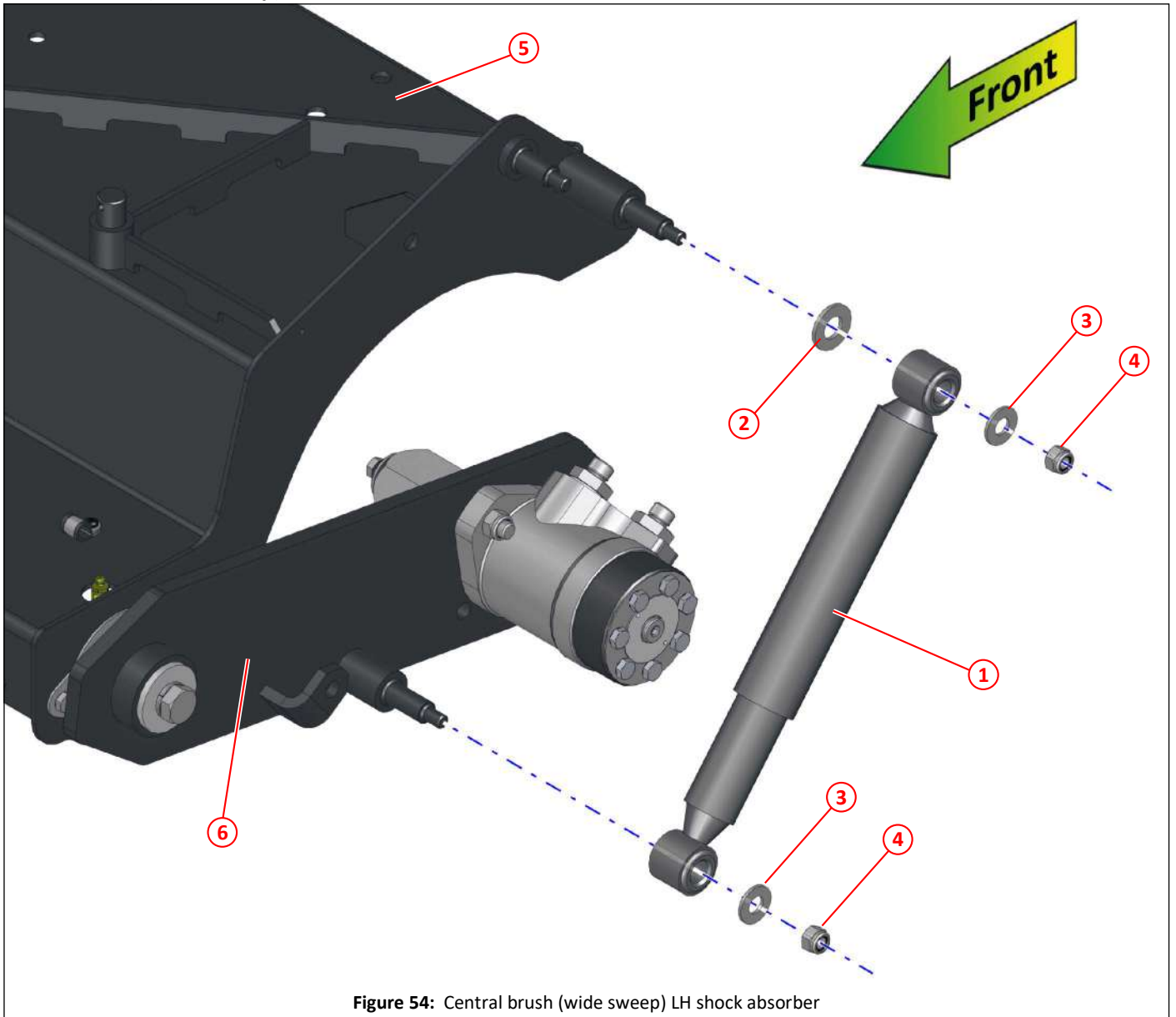

Figure 54: Central brush (wide sweep) LH shock absorber

Item	Part No	Qty	Description	
①	014063	1	Shock absorber 320/500	
②	011135	1	Plain washer M16	
③	011096	2	Plain washer M12	
④	011075	2	Nyloc nut T M10	
⑤	036216	1	Cover, central brush (wide sweep)	
⑥	023077	1	Motor plate LH	

Central brush (wide sweep) LH drive motor

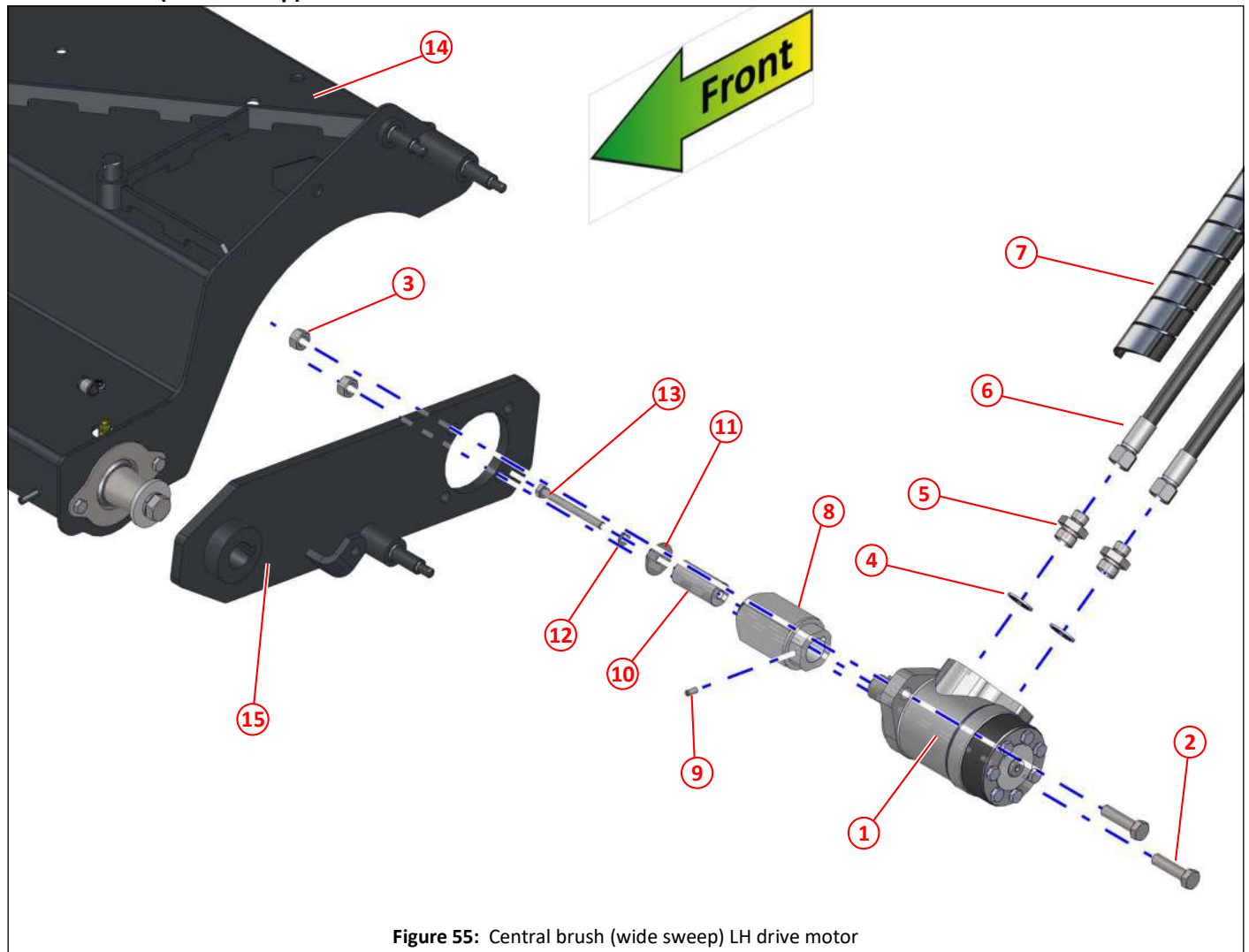

Figure 55: Central brush (wide sweep) LH drive motor

Item	Part No	Qty	Description	
①	010566	1	Motor 3596 (OMP 100)	308
②	011054	2	Setscrew M12 x 45	
③	011076	2	Full nut M12	
④	011154	2	Dowty seal $\frac{1}{2}$ " BSP	
⑤	011167	2	Adapter $\frac{1}{2}$ " BSP x $\frac{3}{8}$ " BSP	
⑥	001167	2	Hose $\frac{3}{8}$ " BSP x 1200, straight	
⑦	004161	1	Flex cable conduit (split) \varnothing 15.7mm, cut to length required	
⑧	024535	1	Drive shaft	
⑨	011112	1	Socket setscrew M6 x 12	
⑩	024538	1	Cone washer	
⑪	038106	1	Spacer, \varnothing 25 x \varnothing 8.5 x 55	
⑫	011093	1	Spring washer M8	
⑬	011415	1	Bolt M8 x 80	
⑭	036216	1	Cover, central brush (wide sweep)	
⑮	023077	1	Motor plate LH	73

Central brush (wide sweep) LH drive motor plate

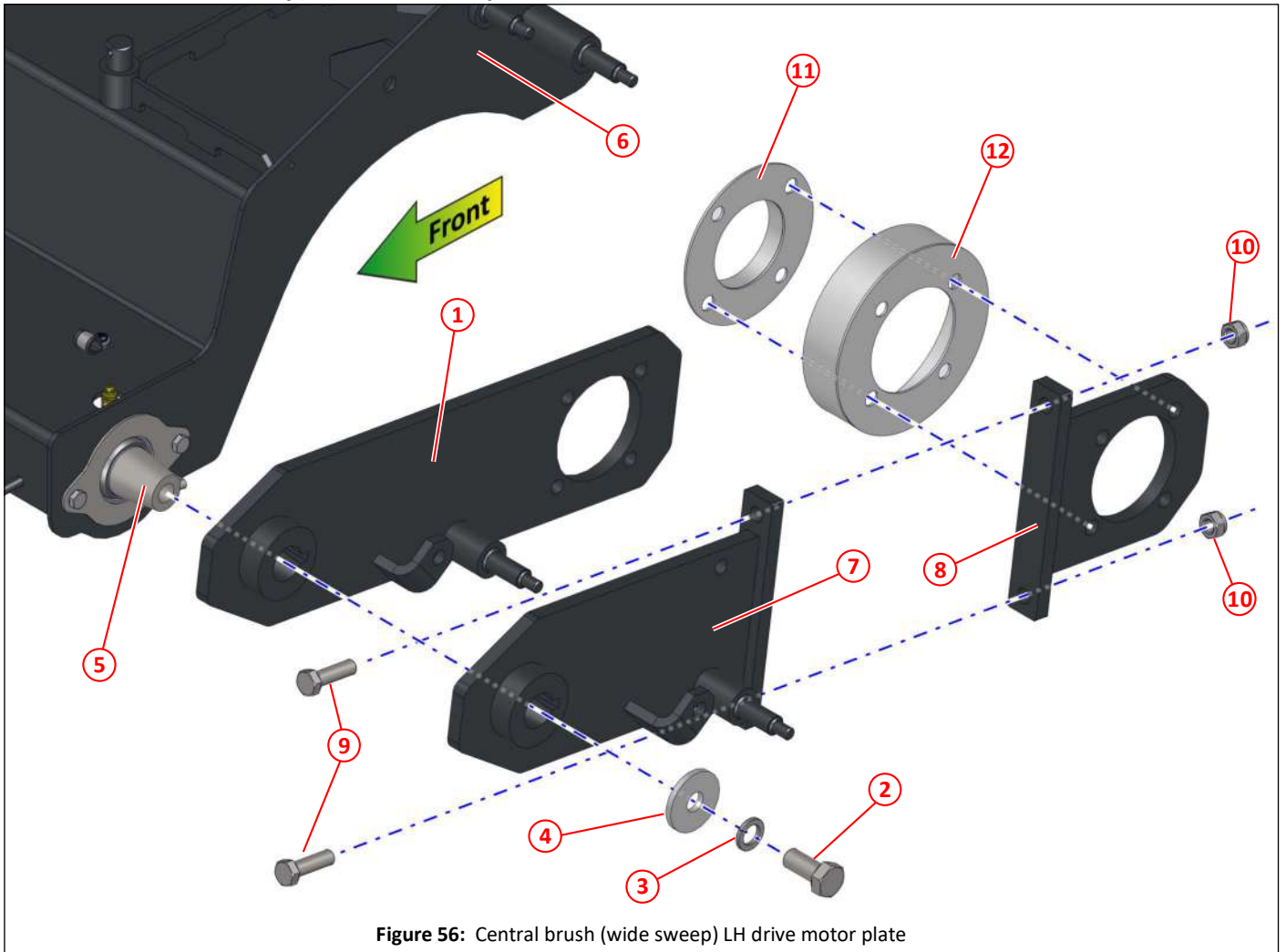

Figure 56: Central brush (wide sweep) LH drive motor plate

Item	Part No	Qty	Description
①	023077	1	Motor plate LH
②	011141	1	Bolt M16 x 35
③	011142	1	Spring washer M16
④	013439	1	Washer, $\phi 50 \times \phi 16.5 \times 5$
⑤	023080	1	Shaft taper
⑥	036216	1	Cover, central brush (wide sweep)
⑦	048977	1	Motor plate LH (bolt on)
⑧	048978	1	Motor fixing plate
⑨	011069	2	Setscrew M12 x 40
⑩	011077	2	Nyloc nut T M12
⑪	046472	1	Motor guard
⑫	049483	1	Motor guard bracket

i If you have item ① this has been replaced with a new assembly, please order **SCA023077RETROFIT** which contains items ⑦, ⑧, ⑨, ⑩, ⑪, and ⑫. This will ensure you get all the required parts to replace item ①.

Central brush (wide sweep) RH raise lower ram

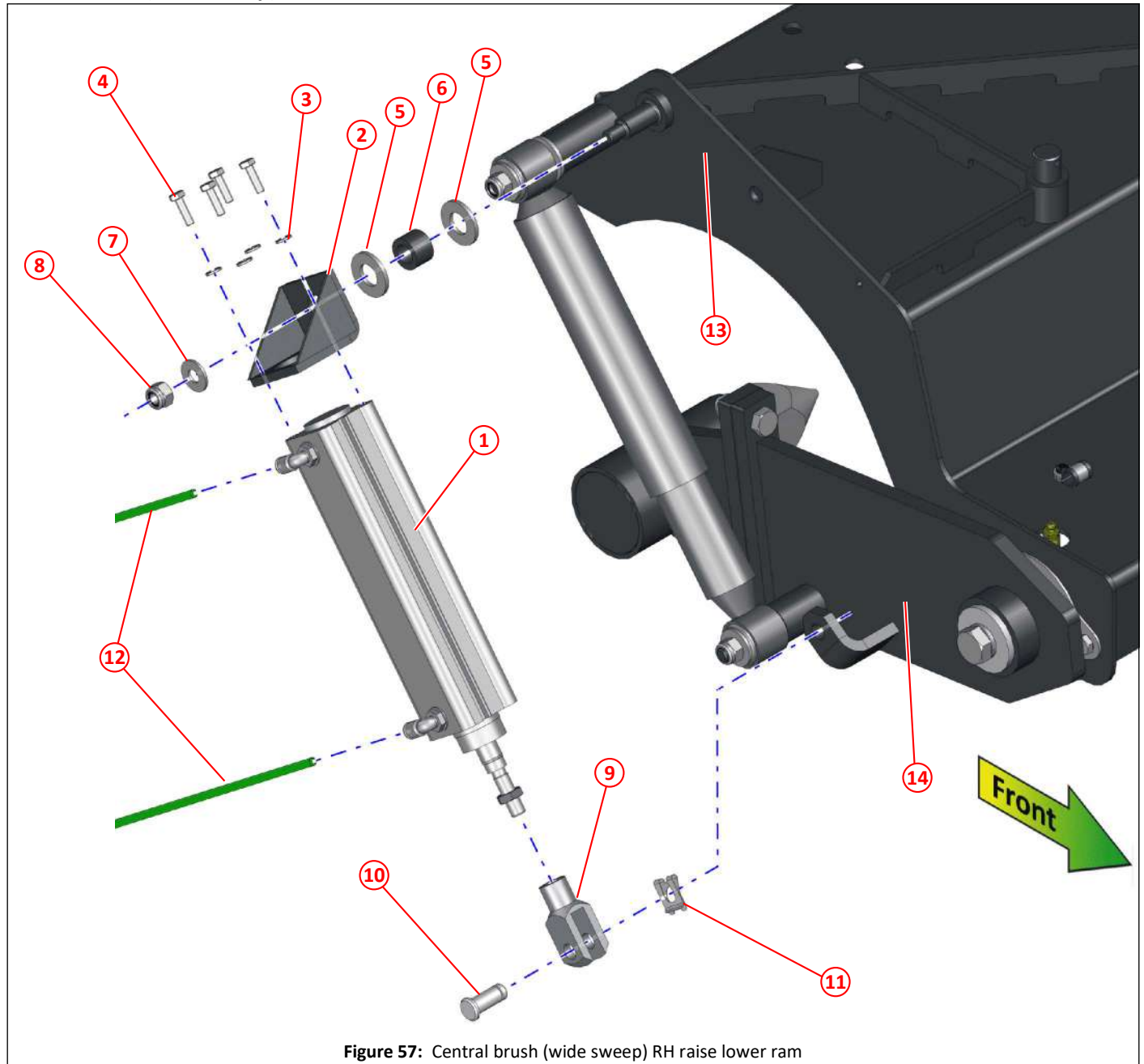

Figure 57: Central brush (wide sweep) RH raise lower ram

Item	Part No	Qty	Description
①	020602	1	Pneumatic cylinder $\phi 40 \times 125$
②	030532	1	Air ram mounting bracket, central brush
③	011091	4	Spring washer M6
④	011067	4	Setscrew M6 x 20
⑤	011135	2	Plain washer M61
⑥	011000	1	Hose $\frac{5}{8}$ " , fuel SAE100R6, cut to 16mm
⑦	011094	1	Plain washer M10
⑧	011075	1	Nyloc nut T M10
⑨	014469	1	Clevis M12
⑩	023270	1	Clevis pin $\phi 12$
⑪	023269	1	Safety fastener $\phi 12$
⑫	024650	2	6mm green air pipe, length as required
⑬	036216	1	Cover, central brush (wide sweep)
⑭	023078	1	Bearing plate RH

Central brush (wide sweep) RH shock absorber

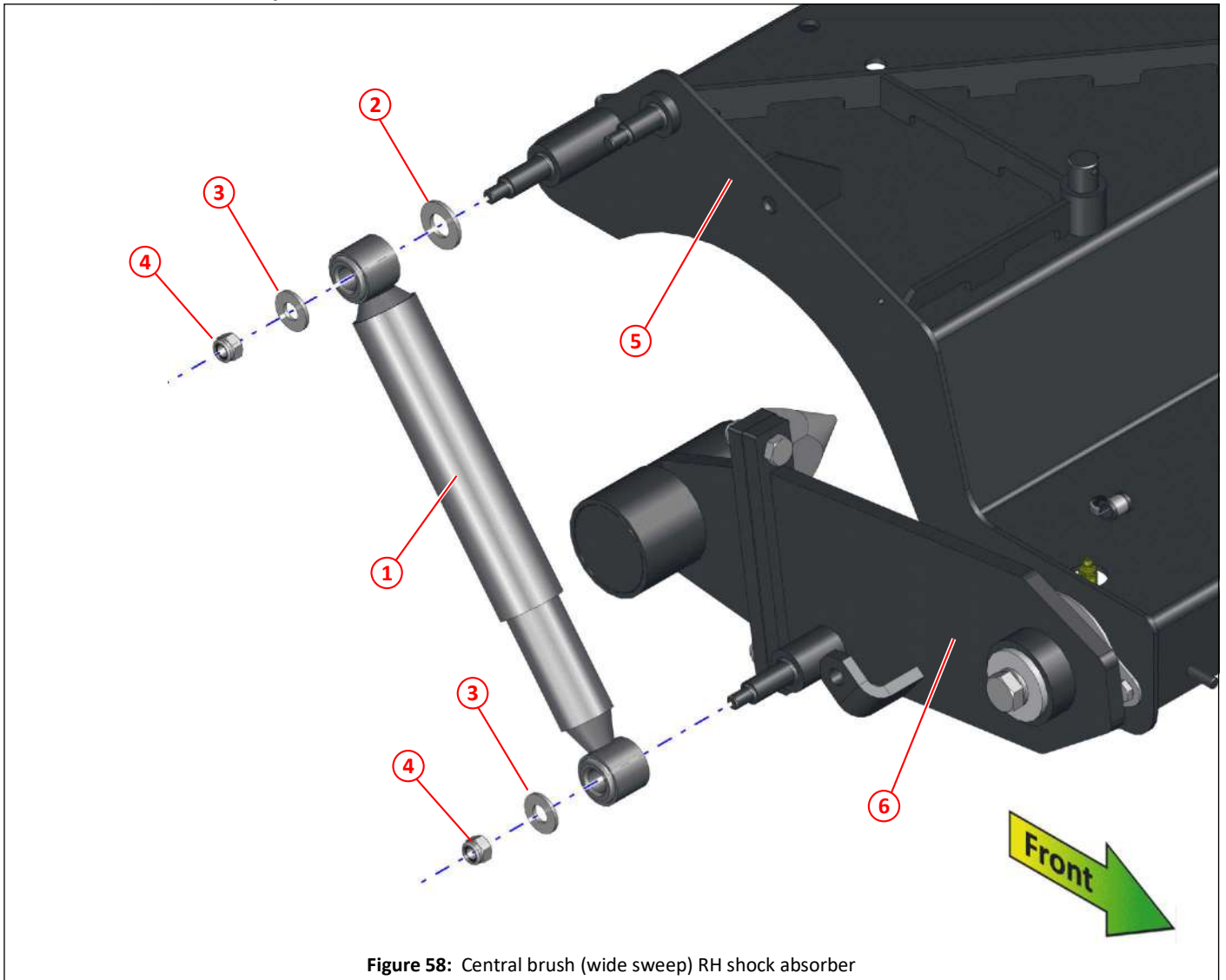

Figure 58: Central brush (wide sweep) RH shock absorber

Item	Part No	Qty	Description
①	014063	1	Shock absorber 320/500
②	011135	1	Plain washer M16
③	011096	2	Plain washer M12
④	011075	2	Nyloc nut T M10
⑤	036216	1	Cover, central brush (wide sweep)
⑥	023078	1	Bearing plate LH

Central brush (wide sweep) RH bearing support

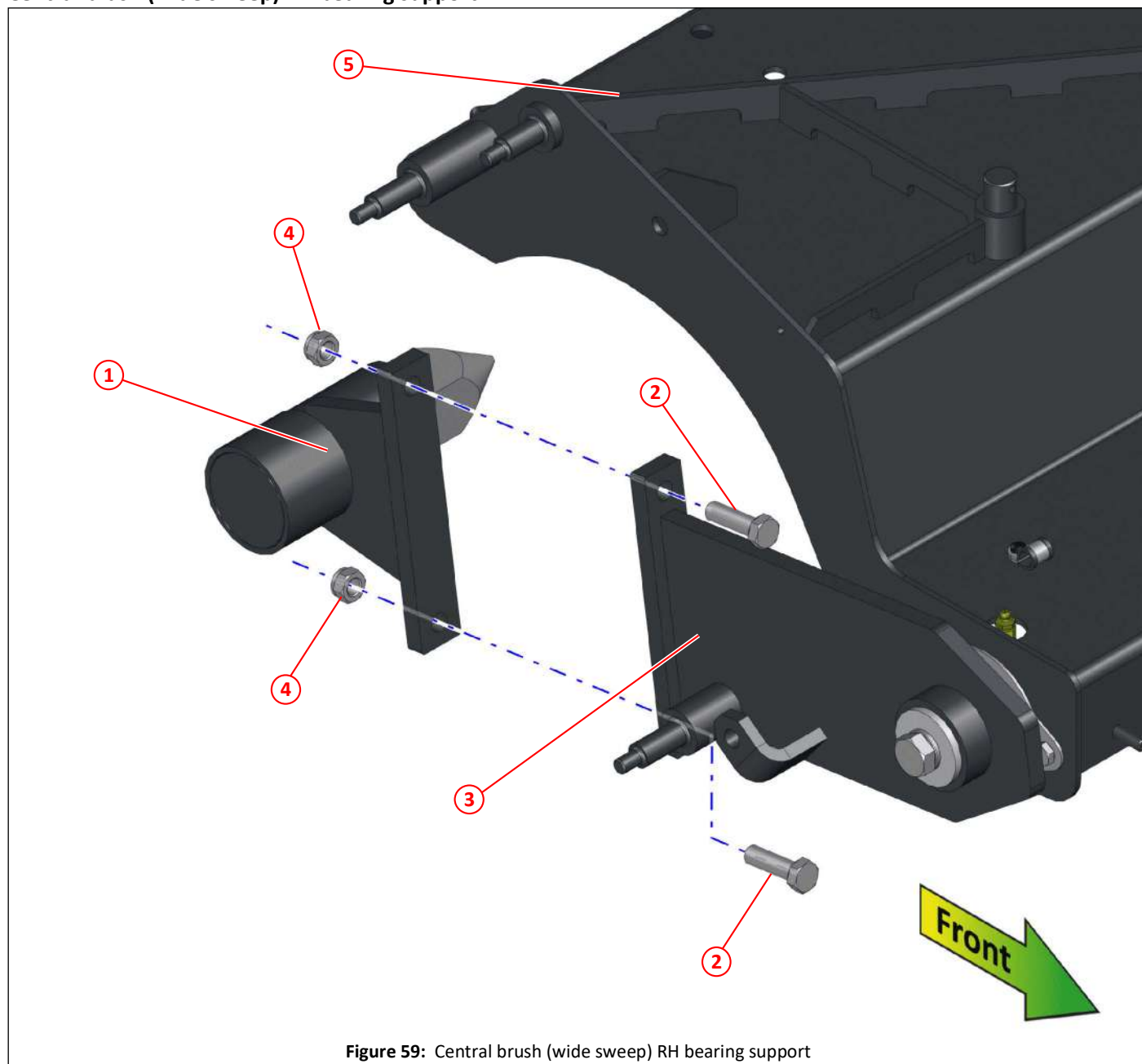

Figure 59: Central brush (wide sweep) RH bearing support

Item	Part No	Qty	Description
①	024224	1	Bearing assembly, central brush (wide sweep)
②	011069	2	Bolt M12 x 40
③	023078	1	Bearing plate LH
④	011077	2	Nyloc nut T M12
⑤	036216	1	Cover, central brush (wide sweep)

Central brush (wide sweep) RH bearing mounting plate

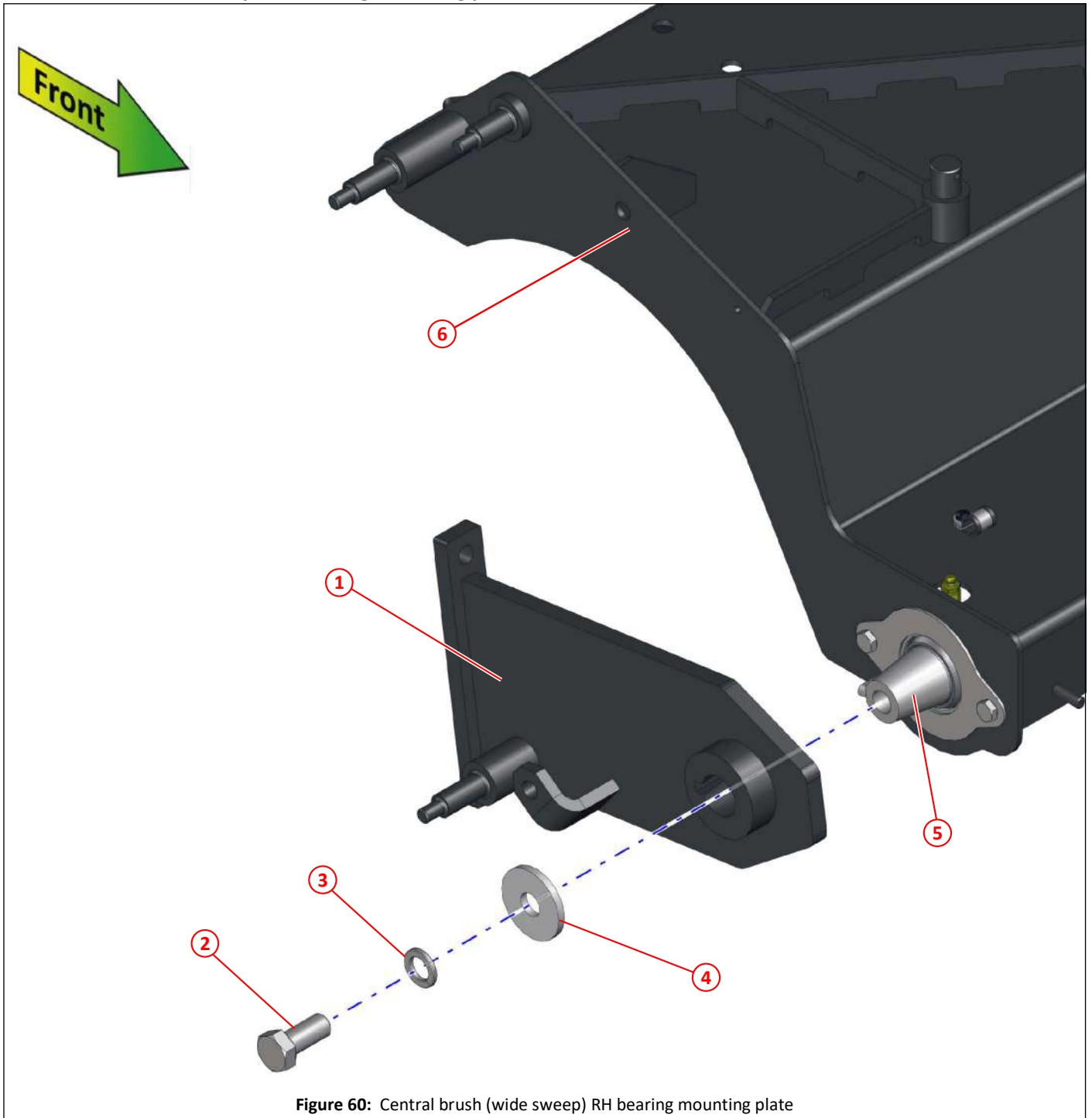

Figure 60: Central brush (wide sweep) RH bearing mounting plate

Item	Part No	Qty	Description
①	023078	1	Bearing plate LH
②	011141	1	Bolt M16 x 35
③	011142	1	Spring washer M16
④	013439	1	Washer, $\varnothing 50 \times \varnothing 16.5 \times 5$
⑤	023080	1	Shaft taper
⑥	036216	1	Cover, central brush (wide sweep)

Central brush (wide sweep), bearing assembly

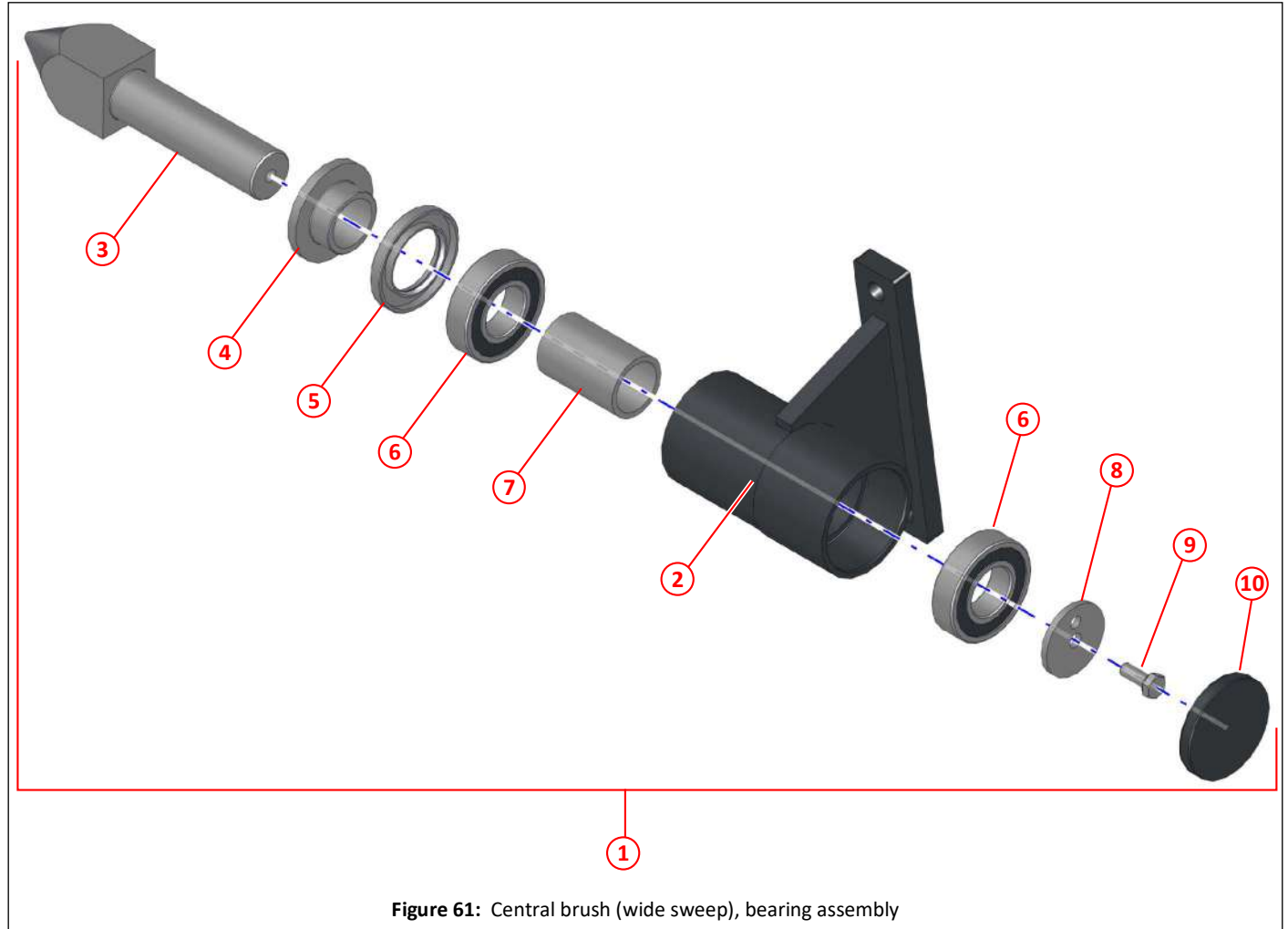

Figure 61: Central brush (wide sweep), bearing assembly

Item	Part No	Qty	Description
①	024224	1	Bearing assembly, central brush (wide sweep)
②	024219	1	Bearing housing, central brush (wide sweep)
③	024223	1	Shaft, central brush (wide sweep)
④	024221	1	Spacer $\varnothing 60 \times \varnothing 30 \times 20$
⑤	024220	1	Oil seal, $\varnothing 62 \times \varnothing 38 \times 7$
⑥	010578	2	Bearing, ball, 6206 2Z
⑦	024531	1	Spacer $\varnothing 38 \times \varnothing 31 \times 58$
⑧	010004	1	Washer $\varnothing 45 \times \varnothing 9 \times 4$
⑨	011010	1	Setscrew M8 x 20
⑩	024222	1	Bearing cap, central brush (wide sweep)

Central brush (wide sweep) bearings and taper shaft

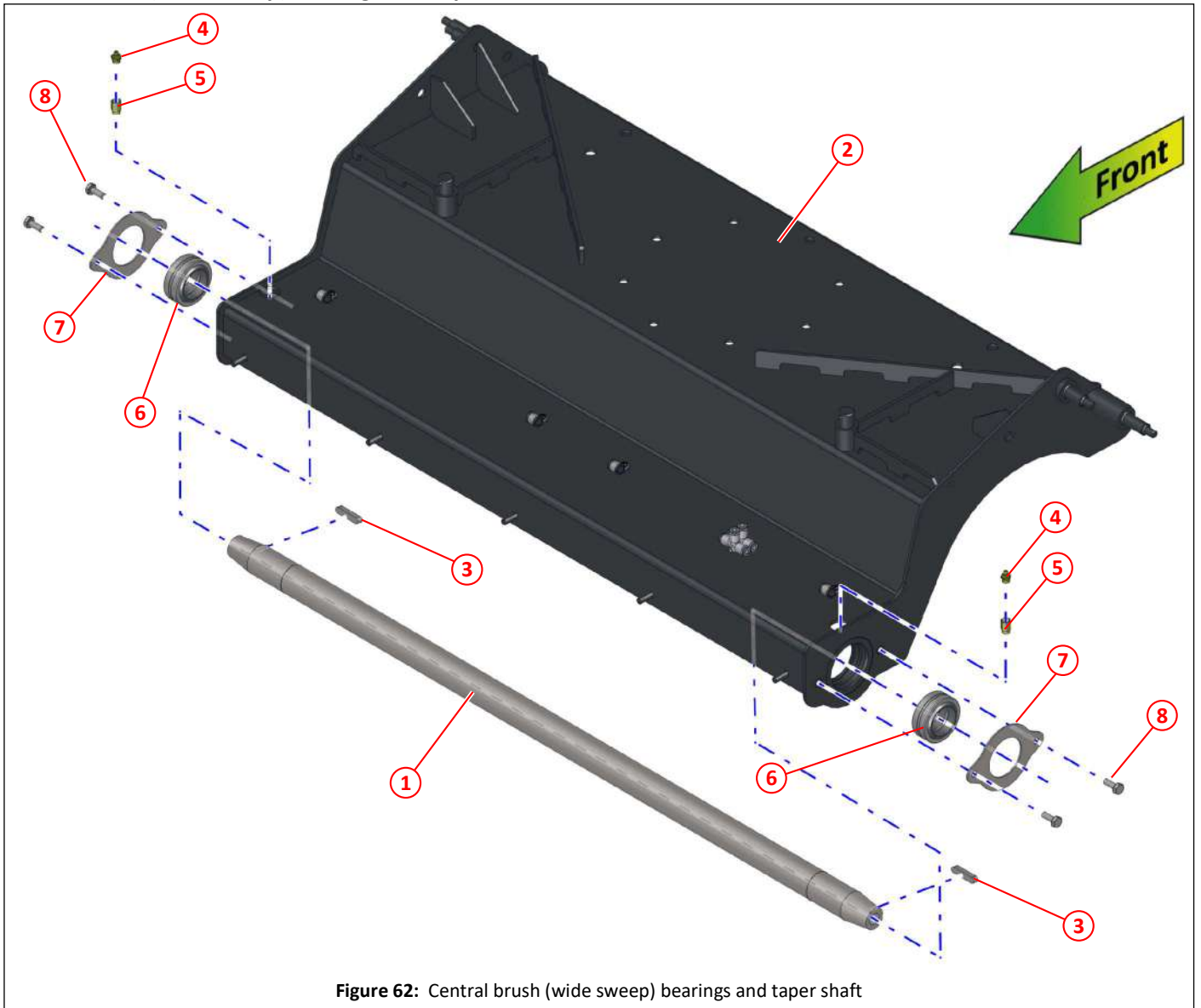

Figure 62: Central brush (wide sweep) bearings and taper shaft

Item	Part No	Qty	Description
①	023080	1	Taper shaft
②	036216	1	Cover, central brush (wide sweep)
③	013292	2	Key
④	010903	2	Grease nipple, straight, $\frac{1}{8}$ " BSP
⑤	040301	2	Grease nipple, extension, $\frac{1}{8}$ " BSP
⑥	036789	2	Spherical bearing
⑦	037172	2	Retainer, spherical bearing
⑧	011010	4	Setscrew M8 x 20

Central brush (wide sweep) spherical bearing LH

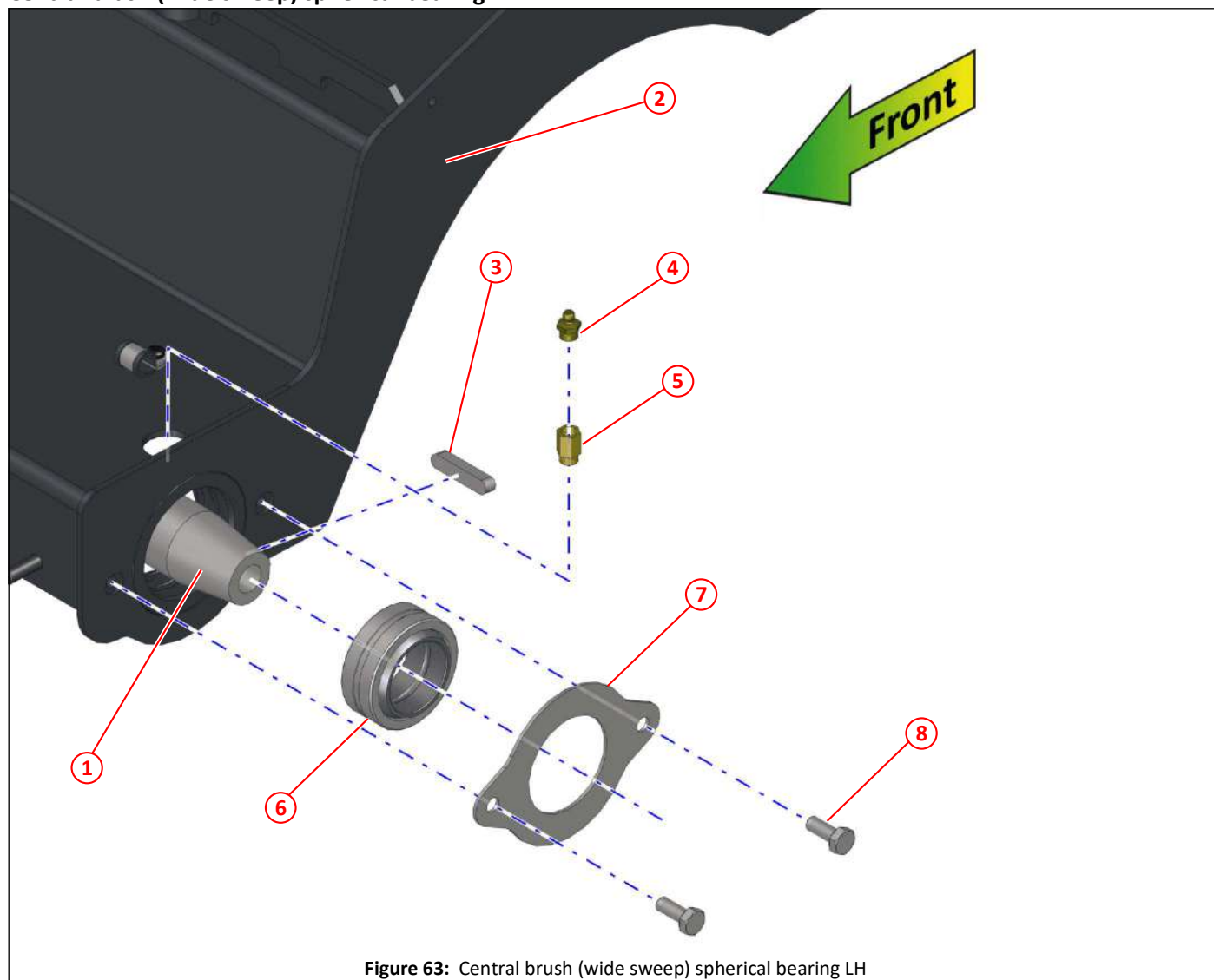

Figure 63: Central brush (wide sweep) spherical bearing LH

Item	Part No	Qty	Description
①	023080	1	Taper shaft
②	036216	1	Cover, central brush (wide sweep)
③	013292	1	Key
④	010903	1	Grease nipple, straight, $\frac{1}{8}$ " BSP
⑤	040301	1	Grease nipple, extension, $\frac{1}{8}$ " BSP
⑥	036789	1	Spherical bearing
⑦	037172	1	Retainer, spherical bearing
⑧	011010	2	Setscrew M8 x 20

Central brush (wide sweep) spherical bearing RH

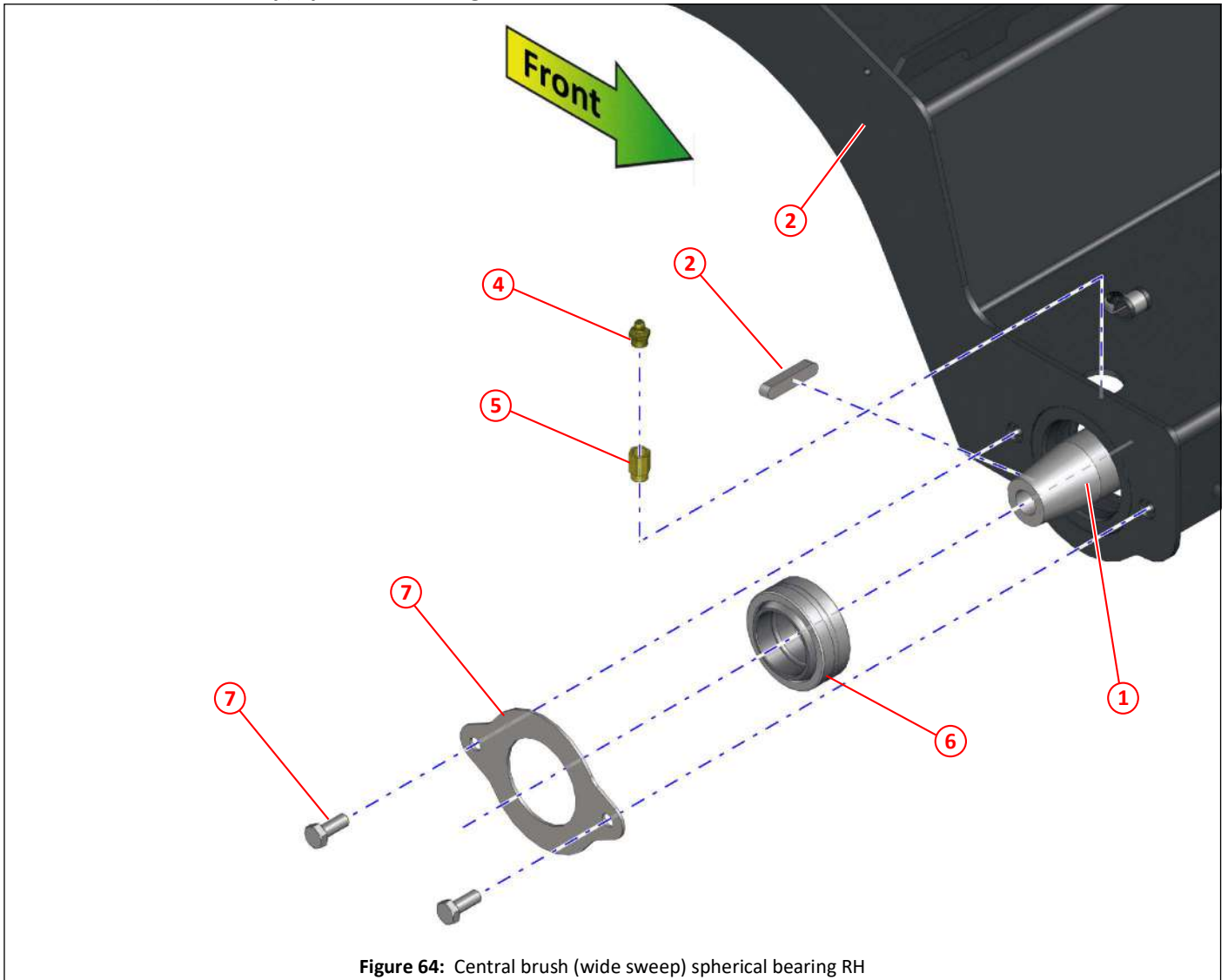

Figure 64: Central brush (wide sweep) spherical bearing RH

Item	Part No	Qty	Description
①	023080	1	Taper shaft
②	036216	1	Cover, central brush (wide sweep)
③	013292	1	Key
④	010903	1	Grease nipple, straight, $\frac{1}{8}$ " BSP
⑤	040301	1	Grease nipple, extension, $\frac{1}{8}$ " BSP
⑥	036789	1	Spherical bearing
⑦	037172	1	Retainer, spherical bearing
⑧	011010	2	Setscrew M8 x 20

Central brush (wide sweep) pneumatic pipes and fittings

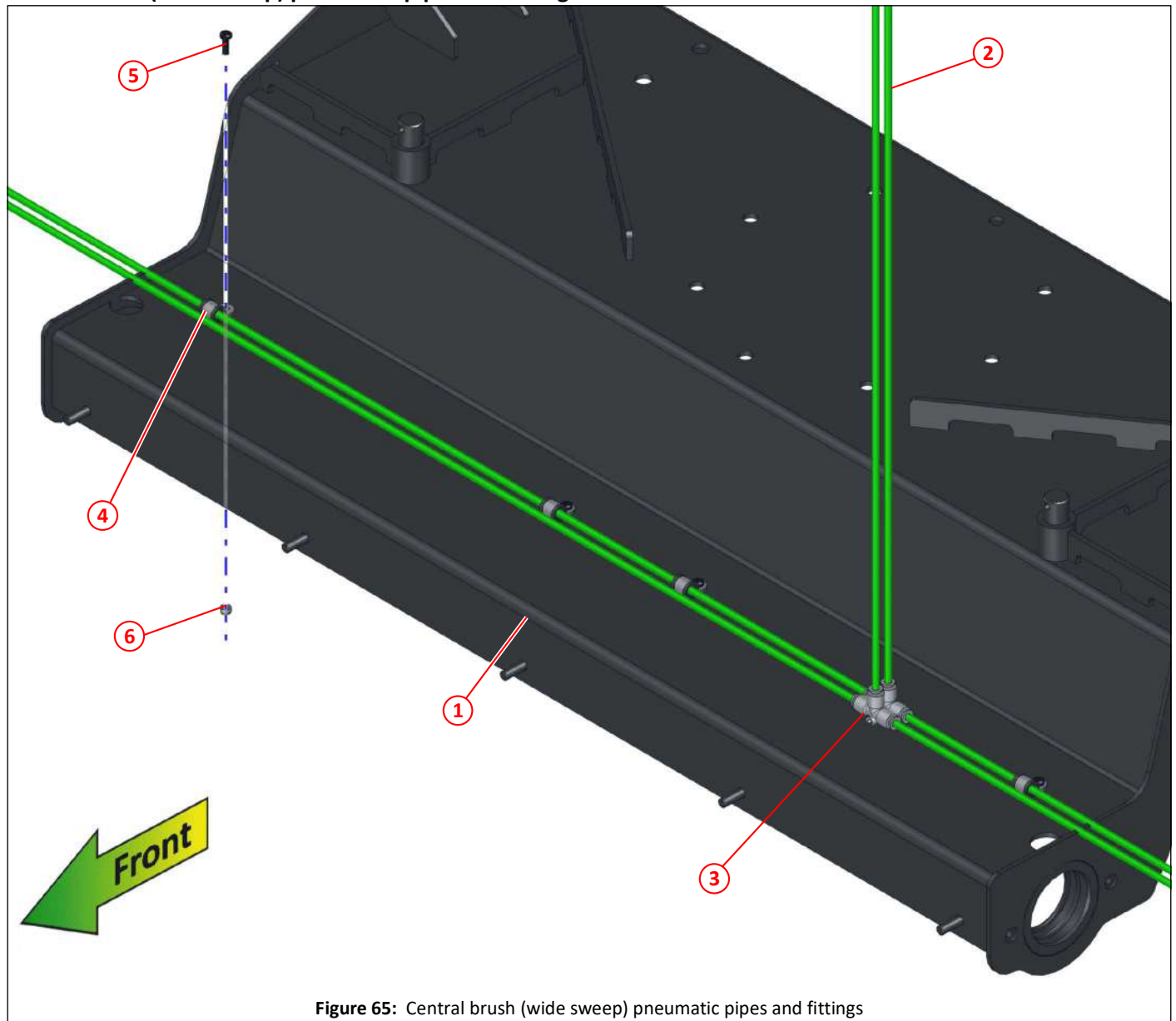

Figure 65: Central brush (wide sweep) pneumatic pipes and fittings

Item	Part No	Qty	Description	
①	036216	1	Cover, central brush (wide sweep)	
②	024650	4	6mm green air pipe, length as required	
③	024647	2	6mm tee grey	
④	021914	4	P-clip \varnothing 12, rubber sealed	
⑤	000234	4	Set screw, pan head pozidriv M5 x 16 black	
⑥	000155	4	Nyloc nut M5	

Central brush (wide sweep), brush core

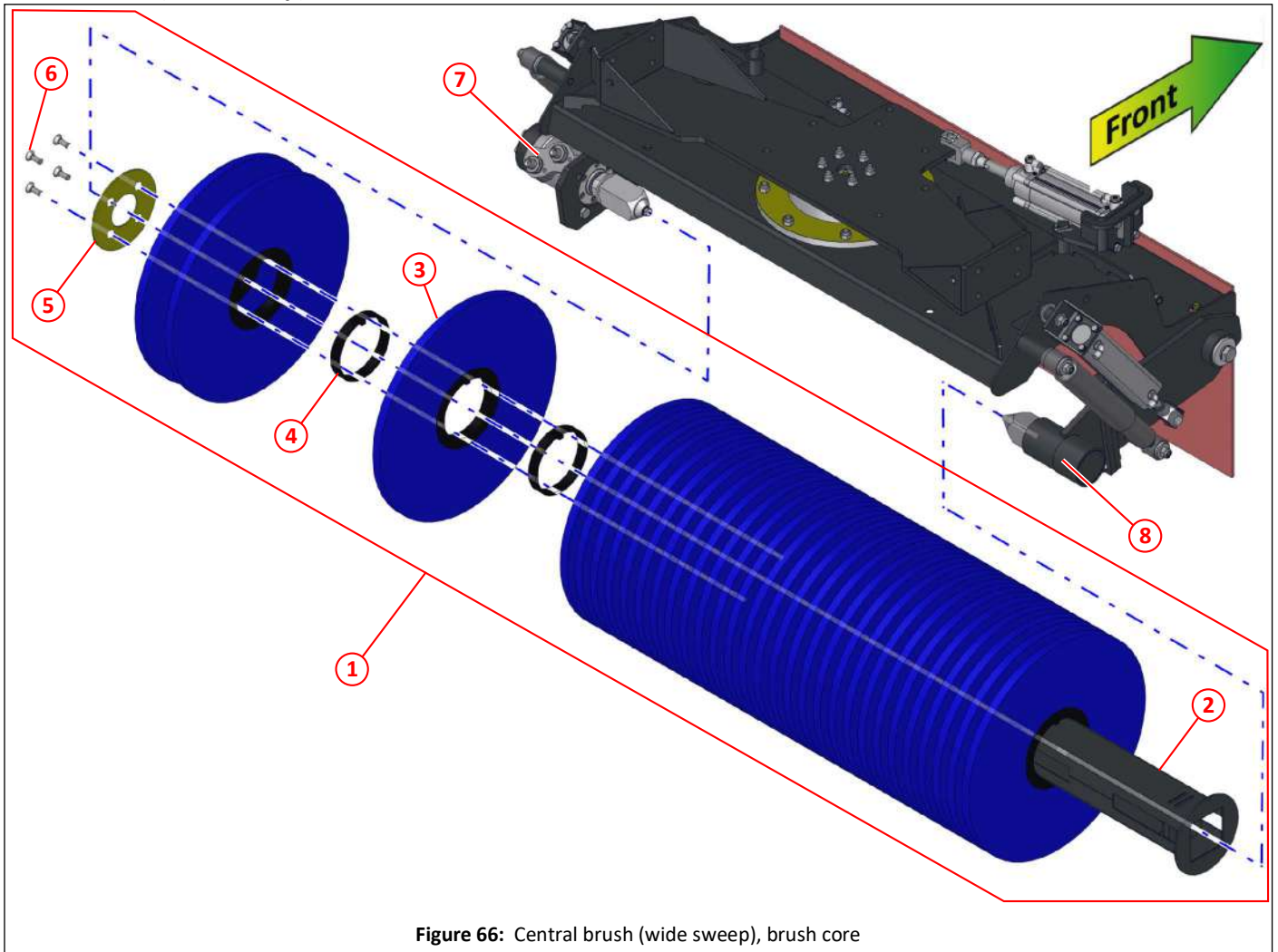

Figure 66: Central brush (wide sweep), brush core

Item	Part No	Qty	Description
①	037588	1	Brush assembly, central brush (wide sweep)
②	013646	1	Brush core
③	023474	31	Brush fill ø400 poly
④	023472	29	Brush spacer
⑤	013649	1	End plate, brush core
⑥	011417	4	Socket cap screw, chamfered, $\frac{3}{8}$ " UNC X 1"
⑦	010566	1	Motor 3596 (OMP 100)
⑧	024224	1	Bearing assembly, central brush (wide sweep)

Suction

<i>Description</i>	<i>Page</i>
Left hand suction nozzle arrangement	87
Left hand suction hose	88
Left hand suction nozzle lift	89
Left hand suction nozzle skirt	90
Left hand suction nozzle frame	91
Left hand suction nozzle tow hitch	92
Left hand suction nozzle pivot	93
Left hand suction nozzle tilt ram	94
Left hand suction nozzle tilt return springs	95
Left hand suction nozzle, flaps and skid plate	96
Left hand suction nozzle, water	97
Right hand suction nozzle arrangement	98
Right hand suction hose	99
Right hand suction nozzle lift	100
Right hand suction nozzle skirt	101
Right hand suction nozzle frame	102
Right hand suction nozzle tow hitch	103
Right hand suction nozzle pivot	104
Right hand suction nozzle tilt ram	105
Right hand suction nozzle tilt return springs	106
Right hand suction nozzle, flaps and skid plate	107
Right hand suction nozzle, water	108
Left hand suction spigot	109
Left hand suction spigot water	110
Left hand suction deflector tube	111
Left hand suction deflector	112
Left hand auto blanking, flap lid and arm	113
Left hand auto blanking, pneumatic cylinder	114
Right hand suction spigot	115
Right hand suction spigot water	116
Right hand suction deflector tube	117
Right hand suction deflector	118
Right hand auto blanking, flap lid and arm	119
Right hand auto blanking, pneumatic cylinder	120
Deflector swing plate	121
Standard wander hose arrangement	122
Standard wander hose	123
Hose attachment, standard wander hose	124
Blanking cap plate, standard wander hose	125
Hose hooks, standard wander hose	126
Wander boom arrangement	127
Wander boom, hose and boom tube	128
Wander boom, hose sleeve	129
Wander boom, hinge mounting bracket	130
Wander boom, swivel hinge	131
Wander boom, lift support	132
Wander boom, hose support	133
Wander boom, stowage bracket	134
Wander boom, tube blanking stowage	135
Overhead boom arrangement	136
Overhead boom, elbow and access cover	137
Overhead boom, elbow and bearing	138
Overhead boom, stop	139
Overhead boom, spring anchor	140

Suction



Overhead boom, cuff	141
Overhead boom, spring adjuster	142
Overhead boom, retainer	143
Overhead boom, retrieval hook	144
Overhead boom, hose and coupling	145
Overhead boom, coupling	146
Overhead boom, coupling stowage bracket	147
Overhead boom, boom extension	148
Overhead boom, boom extension hose saver	149
Overhead boom, boom extension tube	150
Overhead boom, boom extension tube stowage brackets	151

Left hand suction nozzle arrangement

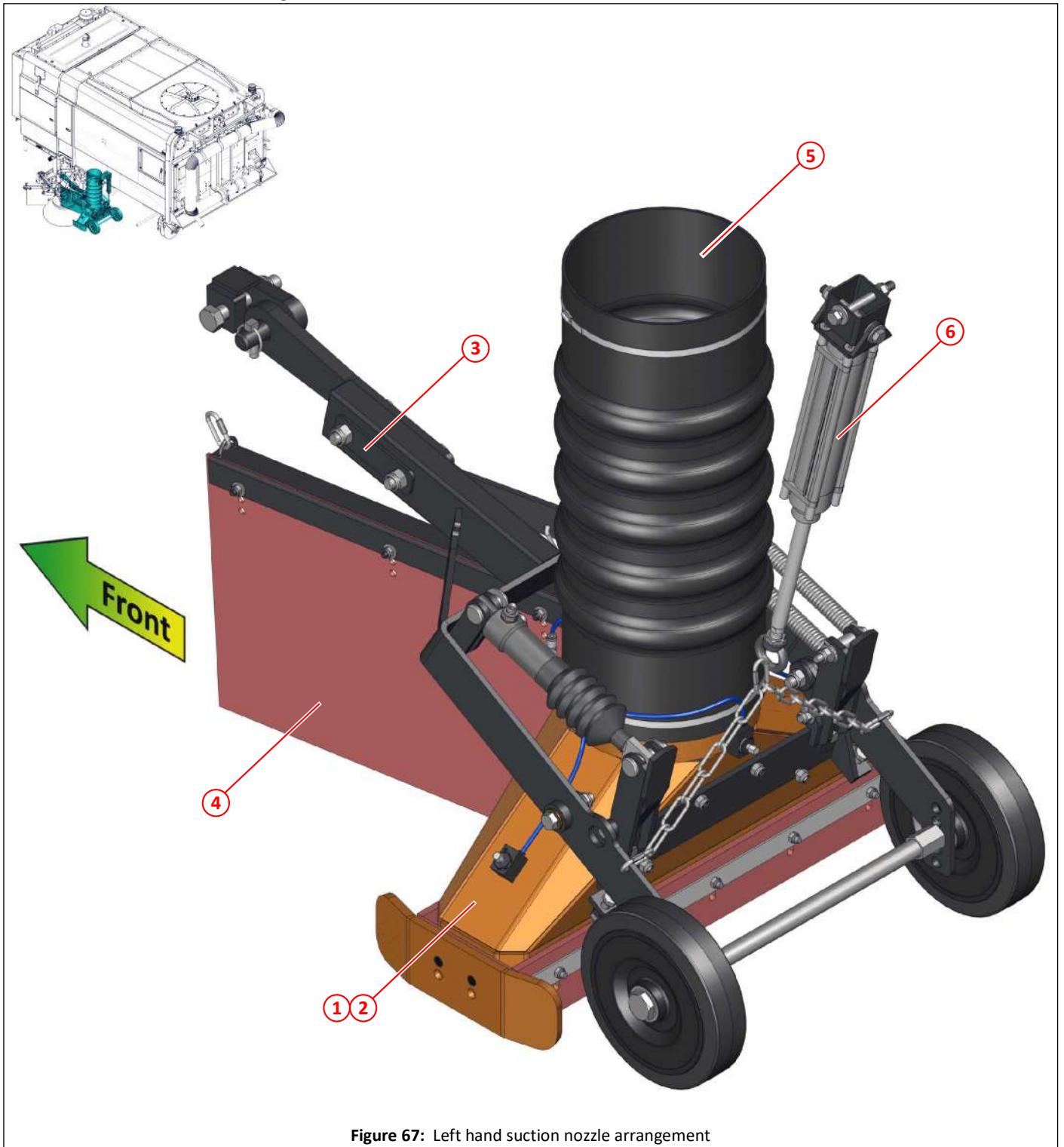

Figure 67: Left hand suction nozzle arrangement

Item	Part No	Qty	Description	
①	047107	1	Suction nozzle	88,96
②	047988	1	Suction nozzle, PU lined	88,96
③	047128	1	Nozzle frame, left hand	88,91,92,93,94,95,97
④	010247	1	Skirt	88
⑤	013028	1	Suction hose	88
⑥	030772	1	Pneumatic cylinder ø50 x 200, nozzle lift	88

Left hand suction hose

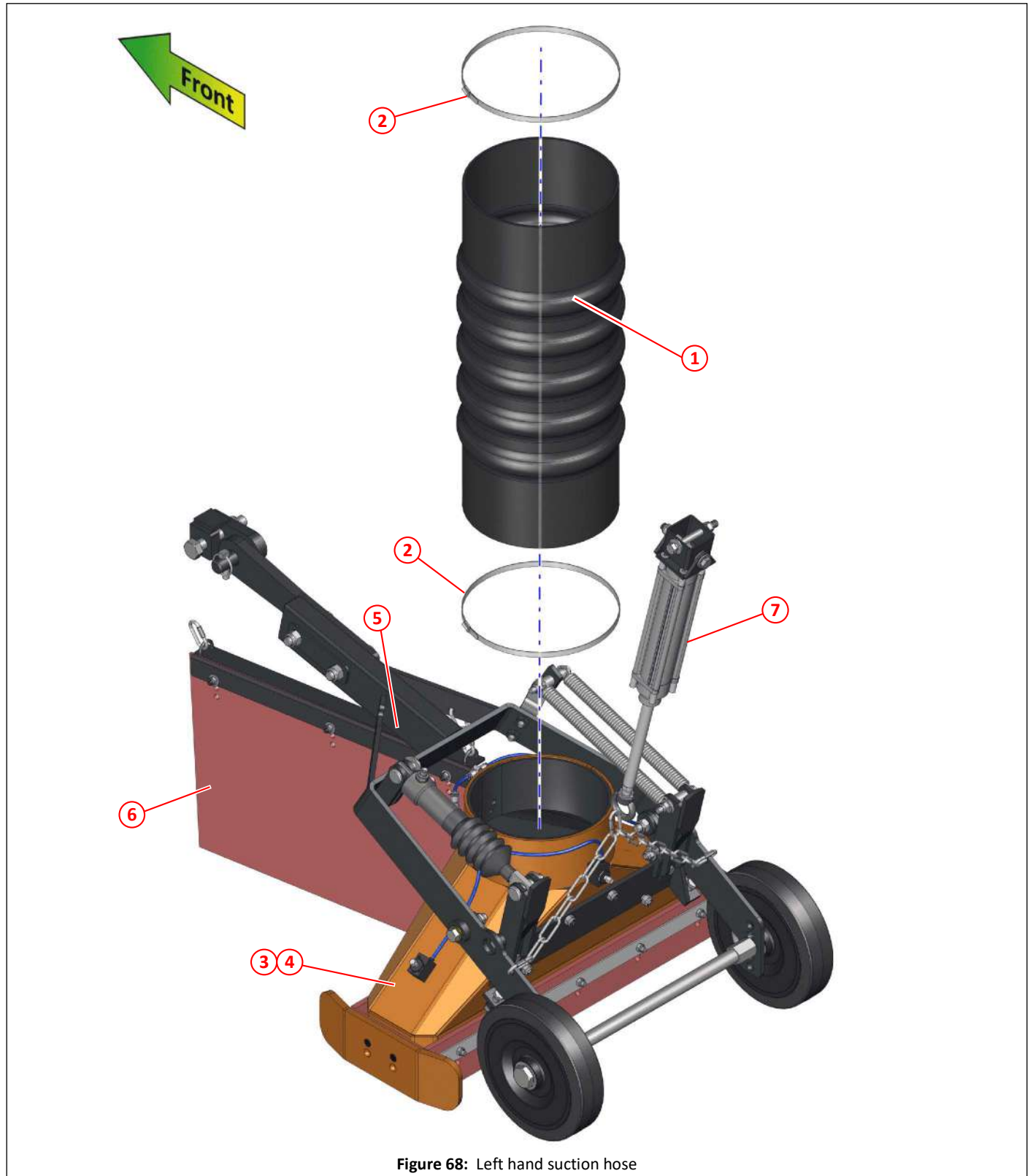

Figure 68: Left hand suction hose

Item	Part No	Qty	Description
①	013028	1	Suction hose
②	012933	1	Jubilee clip No 10.50 (ø235 - ø267)
③	047107	1	Suction nozzle
④	047988	1	Suction nozzle, PU lined
⑤	047128	1	Nozzle frame, left hand
⑥	010247	1	Skirt
⑦	030772	1	Pneumatic cylinder ø50 x 200, nozzle lift

Left hand suction nozzle lift

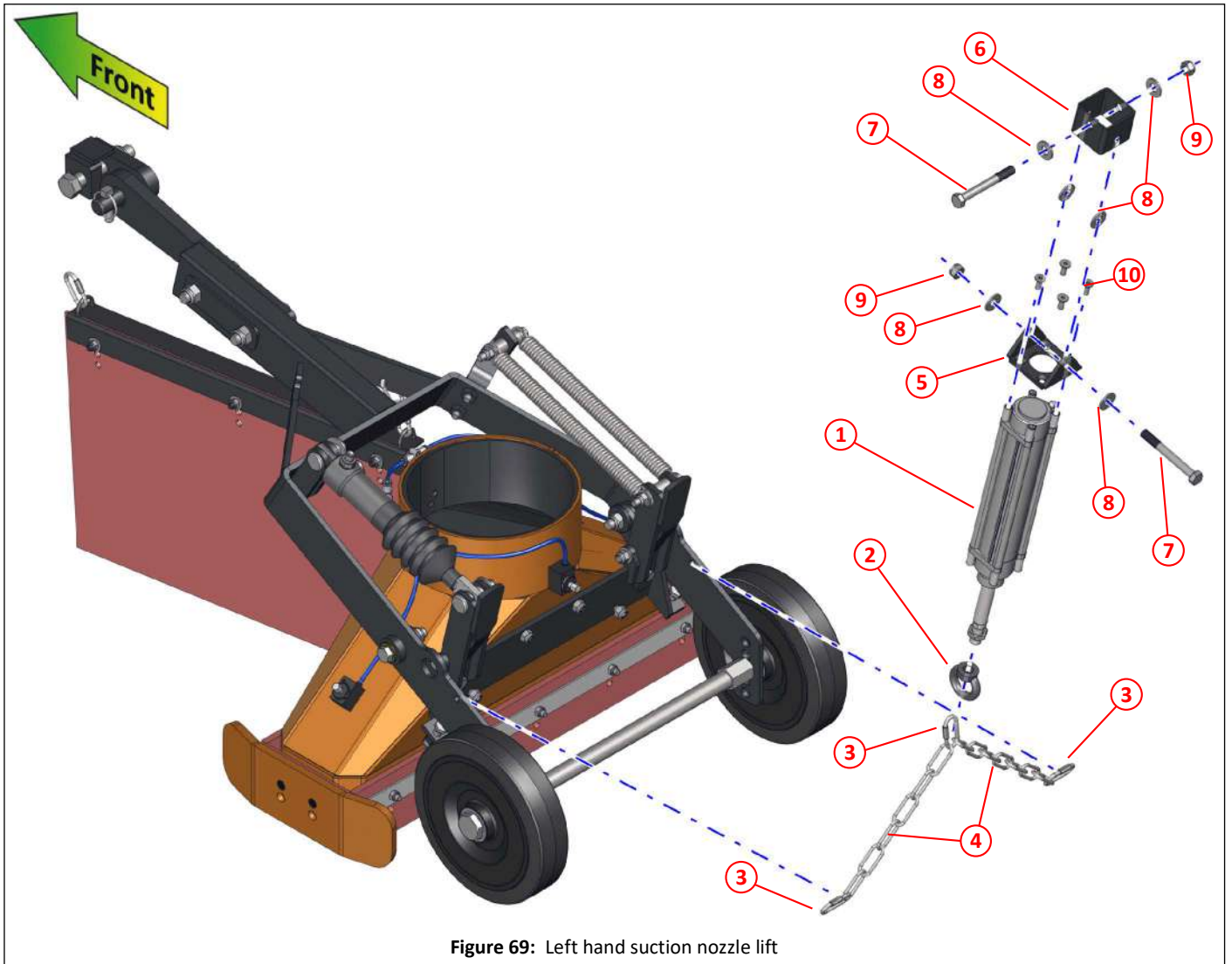

Figure 69: Left hand suction nozzle lift

Item	Part No	Qty	Description
①	030772	1	Pneumatic cylinder $\varnothing 50 \times 200$, nozzle lift
②	032293	1	Ring nut M16 x 1.5
③	010606	3	Caribiner
④	010525	1	Chain, large link, nozzle lift
⑤	030777	1	Pivot, cylinder mount, nozzle lift
⑥	030776	1	Pivot block, nozzle lift
⑦	011057	2	Bolt M12 x 100
⑧	011096	6	Washer M12
⑨	011077	1	Nyloc nut M12
⑩	000003	4	Screw, socket, countersunk, M8 x 20, plated

Left hand suction nozzle skirt

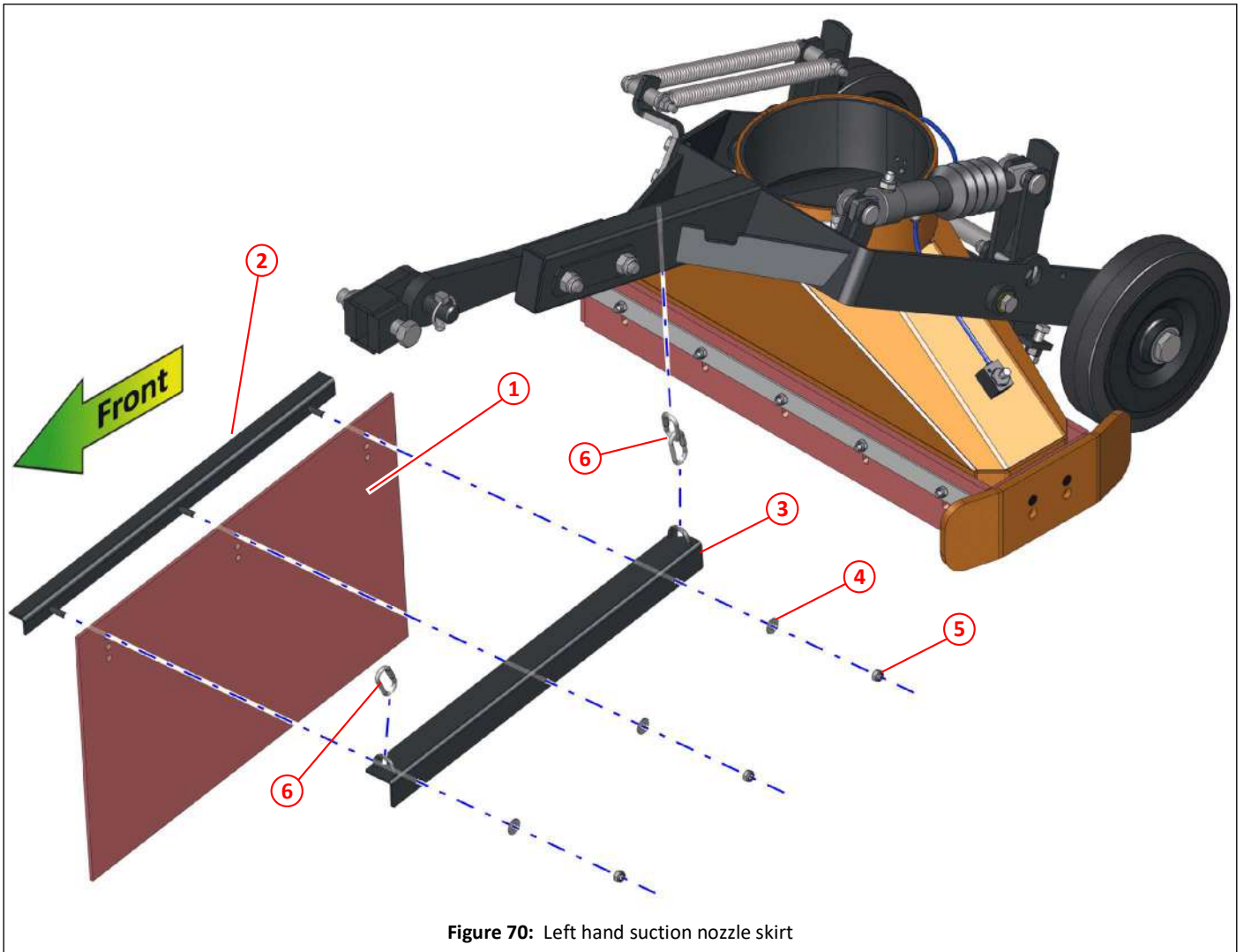

Figure 70: Left hand suction nozzle skirt

Item	Part No	Qty	Description
①	010247	1	Skirt, 3-pitch, heavy duty
②	010275	1	Skirt clamp
③	013145	1	Skirt angle
④	011092	3	Washer M8
⑤	011073	3	Nyloc nut T M8
⑥	010606	3	Caribiner

Left hand suction nozzle frame

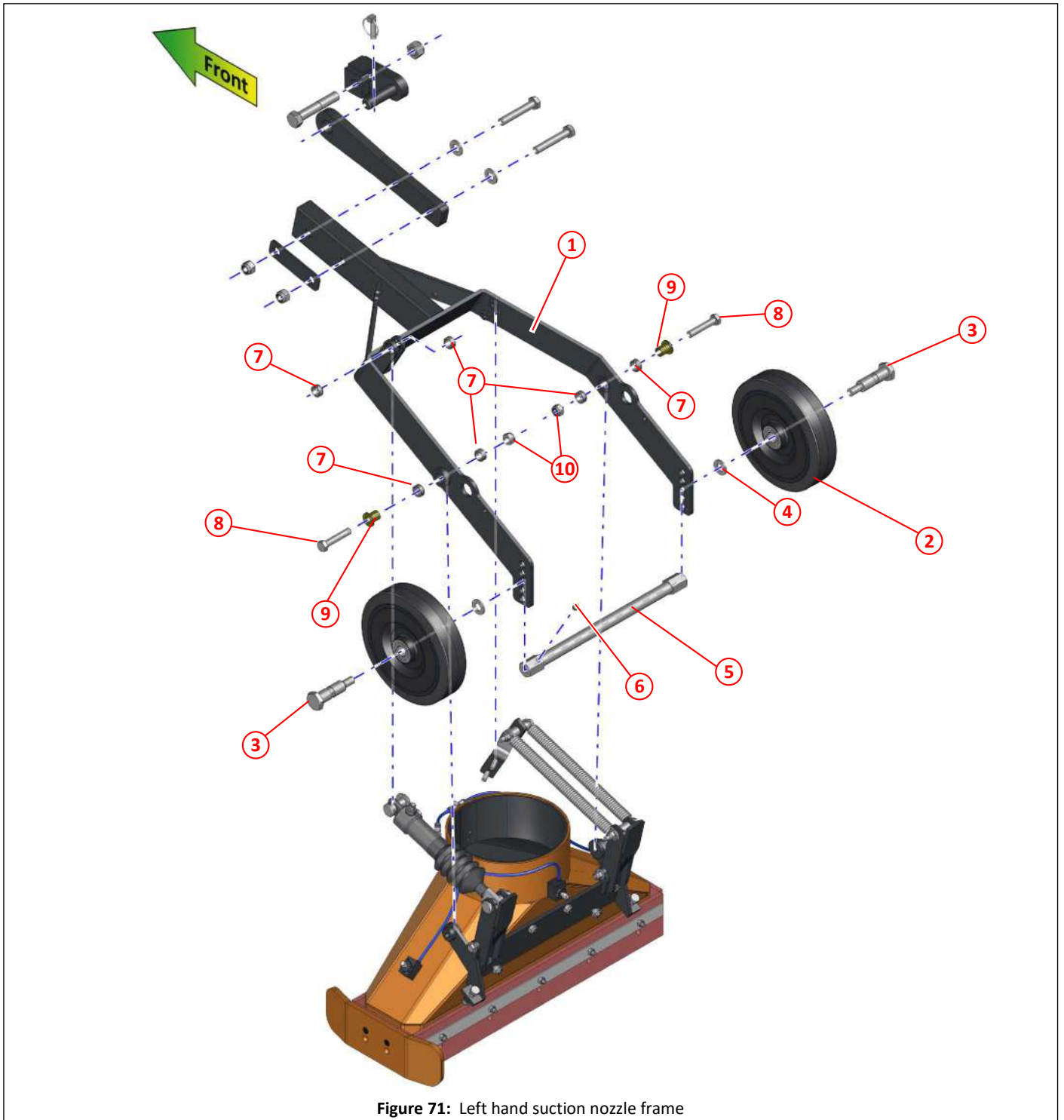

Figure 71: Left hand suction nozzle frame

Item	Part No	Qty	Description
①	047128	1	Nozzle frame, left hand
②	020331	2	Wheel, nozzle, ø250
③	020332	2	Axle bolt, nozzle
④	011135	2	Washer M16
⑤	020333	1	Axle
⑥	010903	1	Grease nipple, straight, 1/8" BSP
⑦	024682	6	Bush ø25 x ø20 x 10
⑧	000351	2	Setscrew M14 x 70
⑨	021416	2	Sleeve, suction nozzle
⑩	011127	2	Nyloc nut T M14

Left hand suction nozzle tow hitch

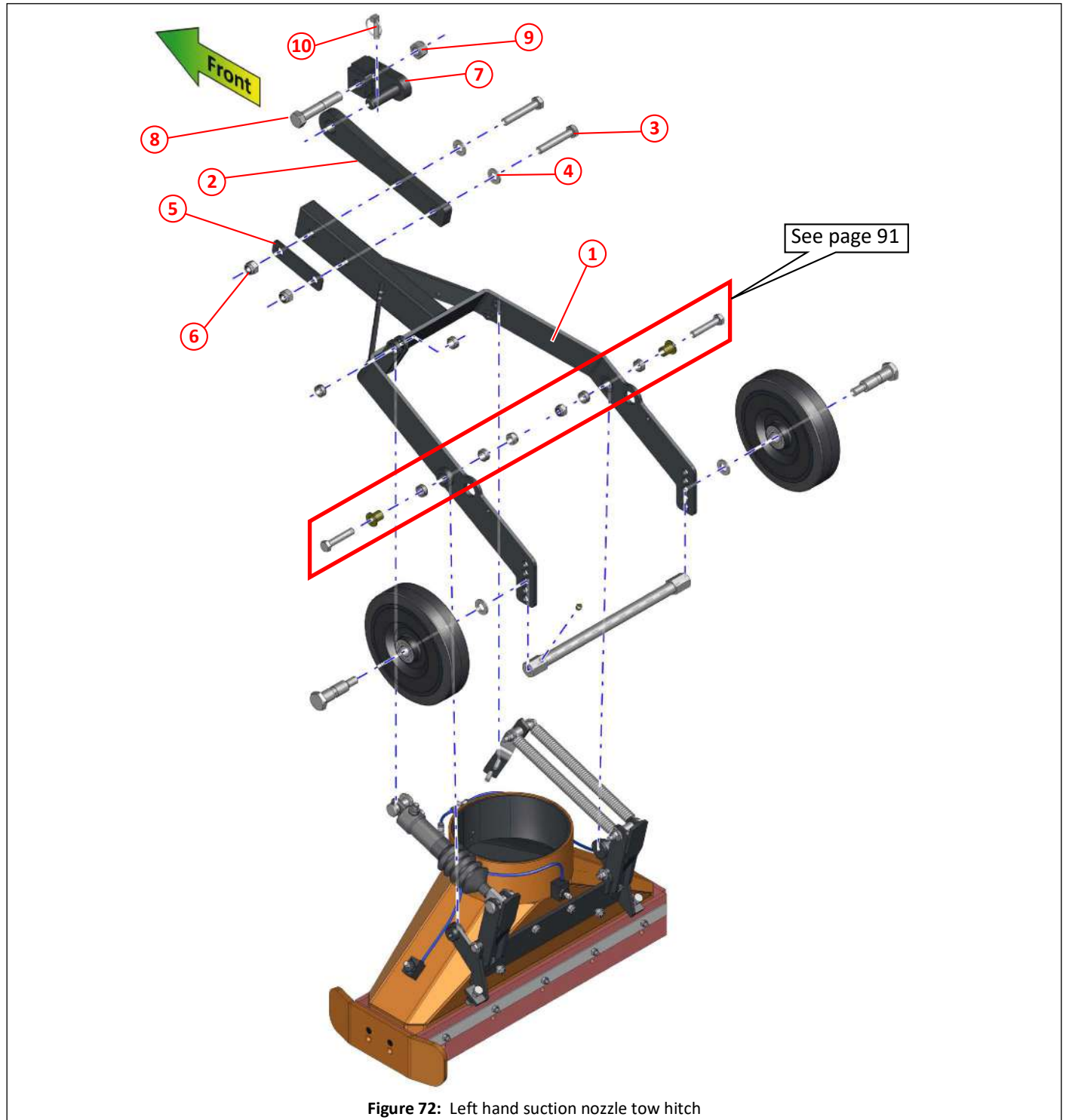

Figure 72: Left hand suction nozzle tow hitch

Item	Part No	Qty	Description
①	047128	1	Nozzle frame, left hand
②	047130	1	Tow hitch, nozzle
③	000043	2	Bolt M16 x 90
④	011135	2	Washer M16
⑤	045492	1	Backing plate
⑥	011060	2	Nyloc nut T M16
⑦	045465	1	Tow pin, nozzle
⑧	011422	1	Bolt M20 x 110
⑨	011082	1	Nyloc nut T M20
⑩	013053	1	Lynch pin

Left hand suction nozzle pivot

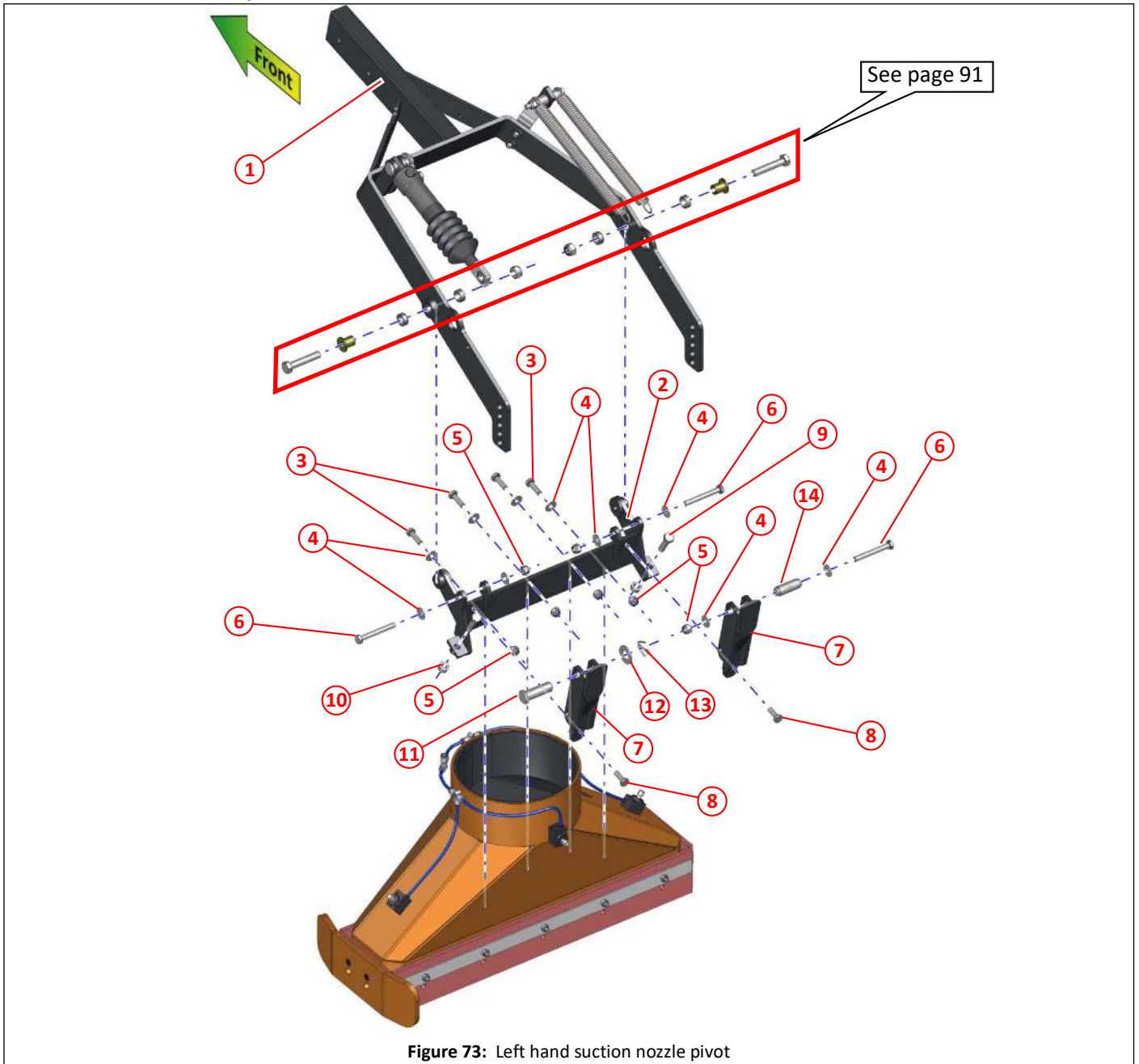

Figure 73: Left hand suction nozzle pivot

Item	Part No	Qty	Description
①	047128	1	Nozzle frame, left hand
②	047114	1	Nozzle pivot
③	011032	4	Setscrew M10 x 30
④	011094	10	Washer M10
⑤	011075	5	Nyloc nut T M10
⑥	011038	3	Bolt M10 x 80
⑦	047116	2	Mounting bracket, spring/ram
⑧	011031	2	Setscrew M10 x 25
⑨	011054	2	Setscrew M12 x 45
⑩	011076	2	Full nut M12
⑪	046749	1	Clevis pin $\varnothing 20 \times 60$
⑫	011102	1	Washer M20
⑬	011122	1	Split pin, $\frac{3}{16}'' \times 1\frac{1}{2}''$
⑭	047136	1	Spring boss $\varnothing 10.5 \times 55$, double stepped

Left hand suction nozzle tilt ram

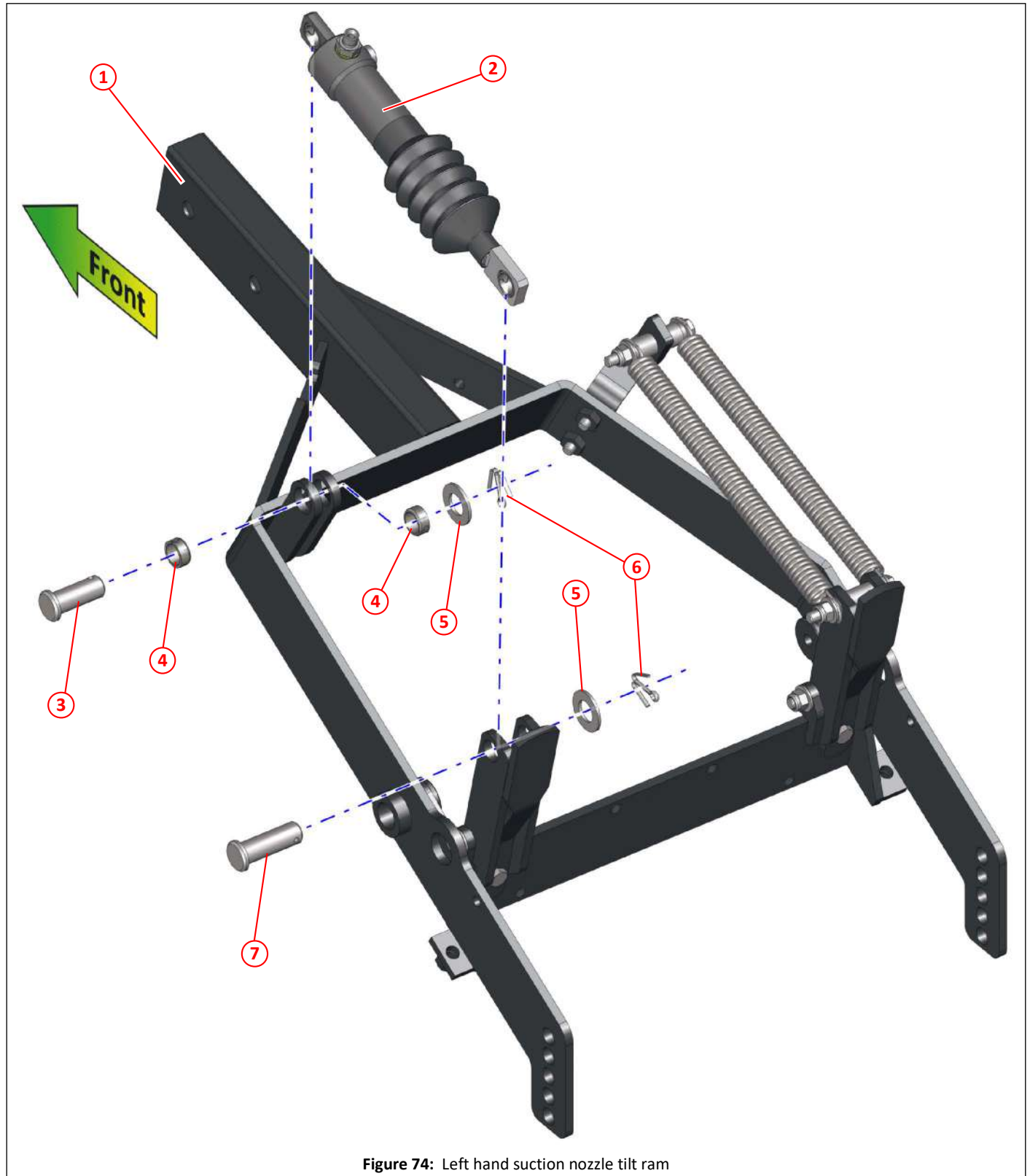

Figure 74: Left hand suction nozzle tilt ram

Item	Part No	Qty	Description
①	047128	1	Nozzle frame, left hand
②	041955	1	Hydraulic ram assembly, nozzle tilt
③	046750	1	Clevis pin $\varnothing 20 \times 50$
④	024682	2	Bush $\varnothing 25 \times \varnothing 20 \times 10$
⑤	011102	2	Washer M20
⑥	011122	2	Split pin, $\frac{3}{16}'' \times 1\frac{1}{2}''$
⑦	046749	1	Clevis pin $\varnothing 20 \times 60$

Left hand suction nozzle tilt return springs

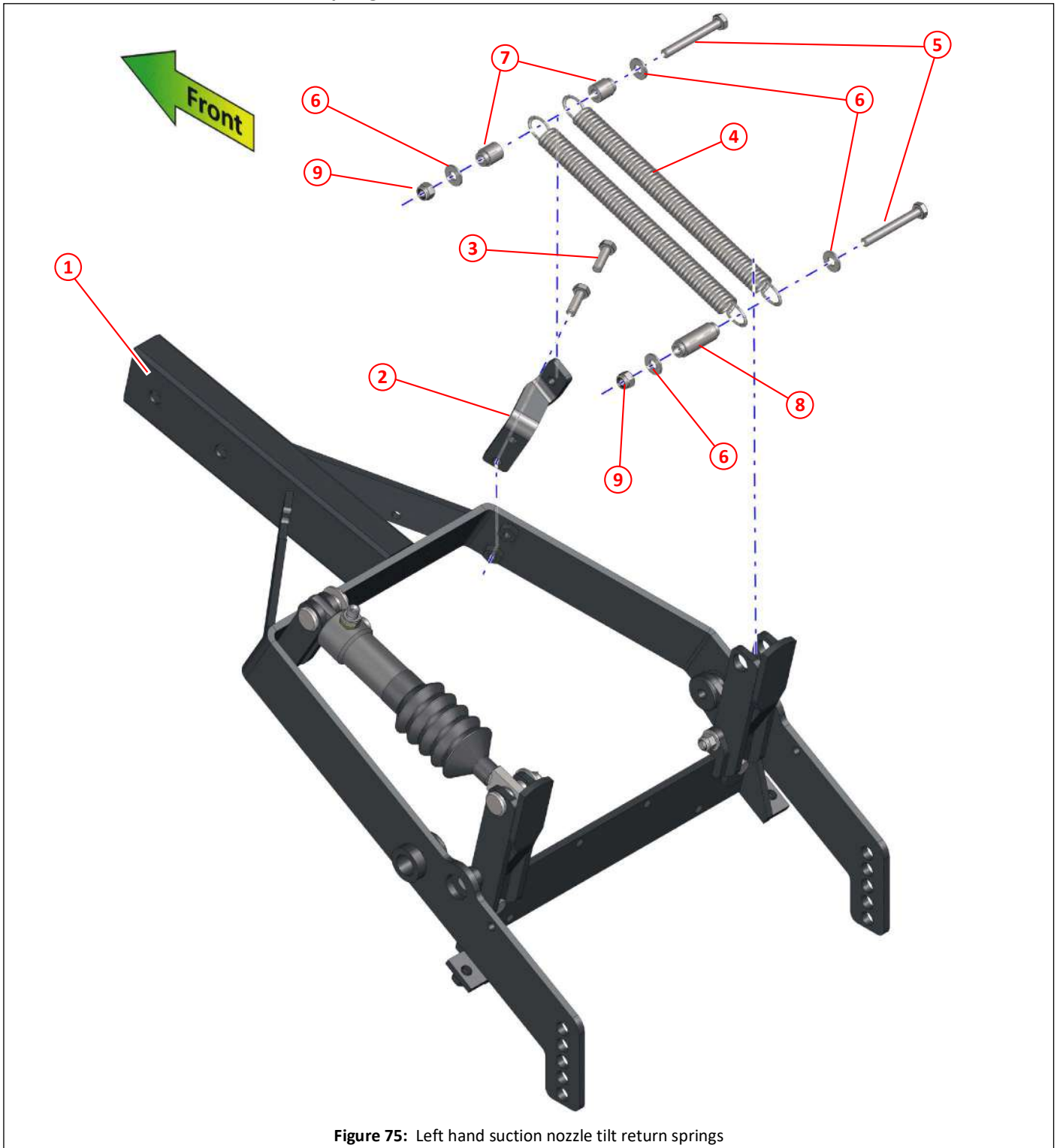

Figure 75: Left hand suction nozzle tilt return springs

Item	Part No	Qty	Description
①	047128	1	Nozzle frame, left hand
②	047126	1	Spring bracket, suction nozzle, left hand
③	011032	2	Setscrew M10 x 30
④	010017	2	Spring
⑤	011038	2	Bolt M10 x 80
⑥	011094	4	Washer M10
⑦	047135	2	Spring boss, $\phi 10.5 \times 23.5$, stepped
⑧	047136	1	Spring boss $\phi 10.5 \times 55$, double stepped
⑨	011075	2	Nyloc nut T M10

Left hand suction nozzle, flaps and skid plate

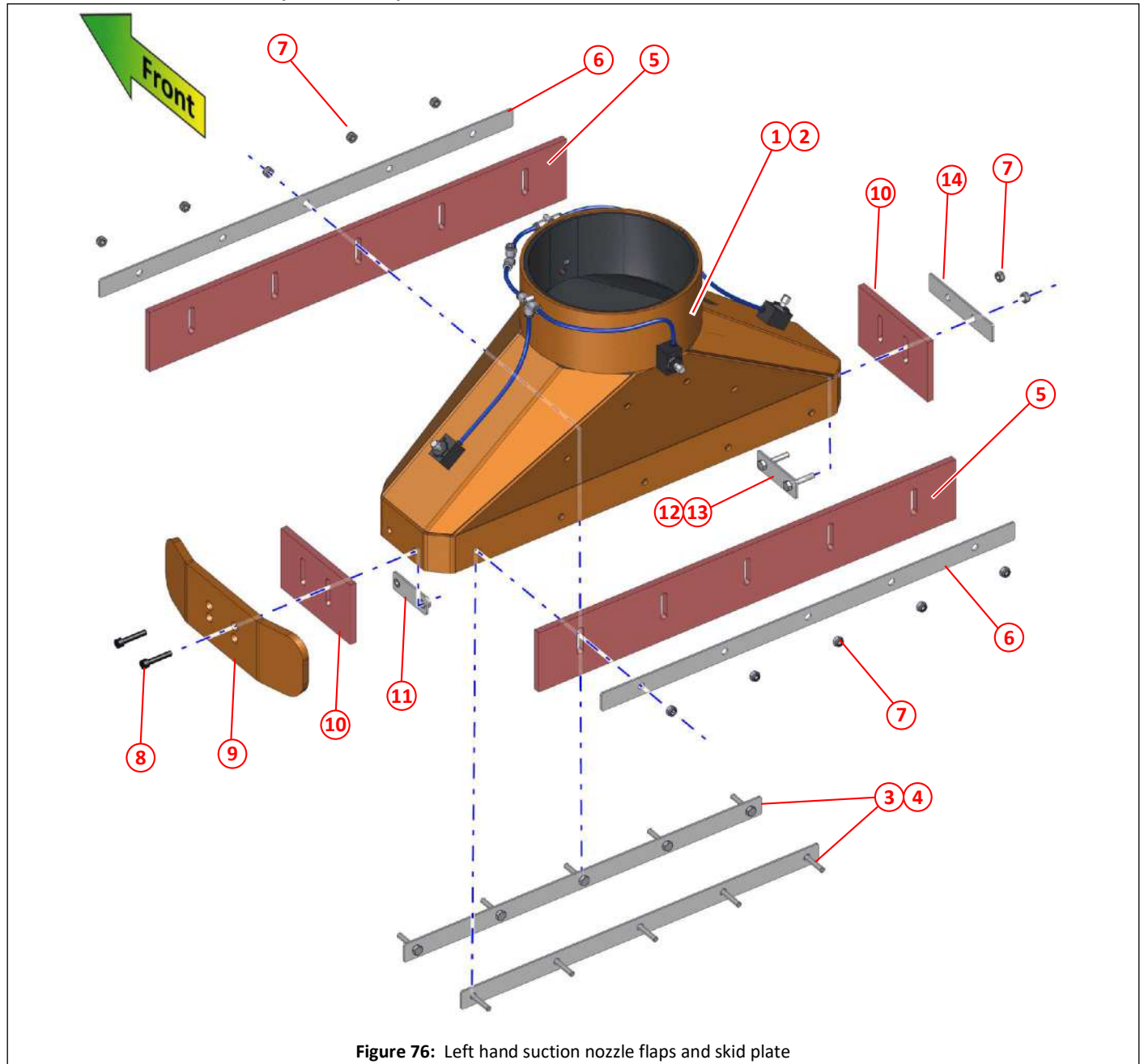

Figure 76: Left hand suction nozzle flaps and skid plate

Item	Part No	Qty	Description
①	047107	1	Suction nozzle
②	047988	1	Suction nozzle, PU lined
③	047110	2	Flap clamp, long
④	048513	2	Flap clamp, long, for PU lined suction nozzle
⑤	047108	2	Flap, long, suction nozzle
⑥	047112	2	Flap clamp strip, long
⑦	011073	12	Nyloc nut T M8
⑧	000096	2	Socket cap screw M8 x 40
⑨	047115	1	Skid plate
⑩	047109	2	Flap, short
⑪	047323	1	Skid plate clamp strip
⑫	047113	1	Flap clamp, short
⑬	048512	1	Flap clamp, short, for PU lined suction nozzle
⑭	047111	1	Flap clamp strip, short

Left hand suction nozzle, water

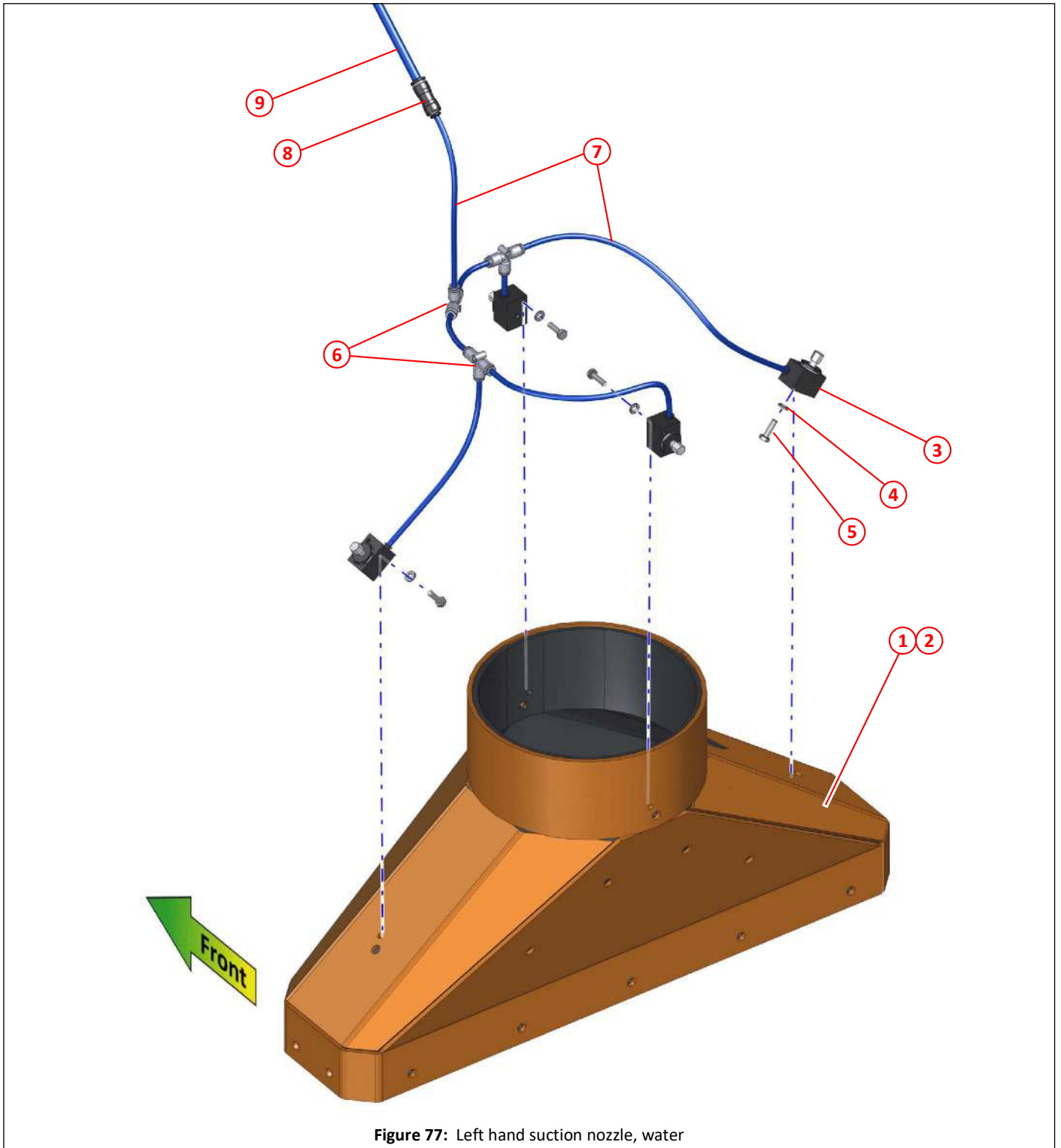

Figure 77: Left hand suction nozzle, water

Item	Part No	Qty	Description
①	047107	1	Suction nozzle
②	047988	1	Suction nozzle, PU lined
③	034342	4	Water nozzle, low pressure
④	011091	4	Spring washer M6
⑤	011067	4	Setscrew M6 x 20
⑥	024647	3	6mm Tee, grey
⑦	035733	6	Blue flexible nylon tubing, ϕ 6mm, (length as required)
⑧	041029	1	Push in adapter, straight, ϕ 10mm to ϕ 6mm
⑨	041031	1	Blue flexible nylon tubing, ϕ 10mm, (length as required)

Right hand suction nozzle arrangement

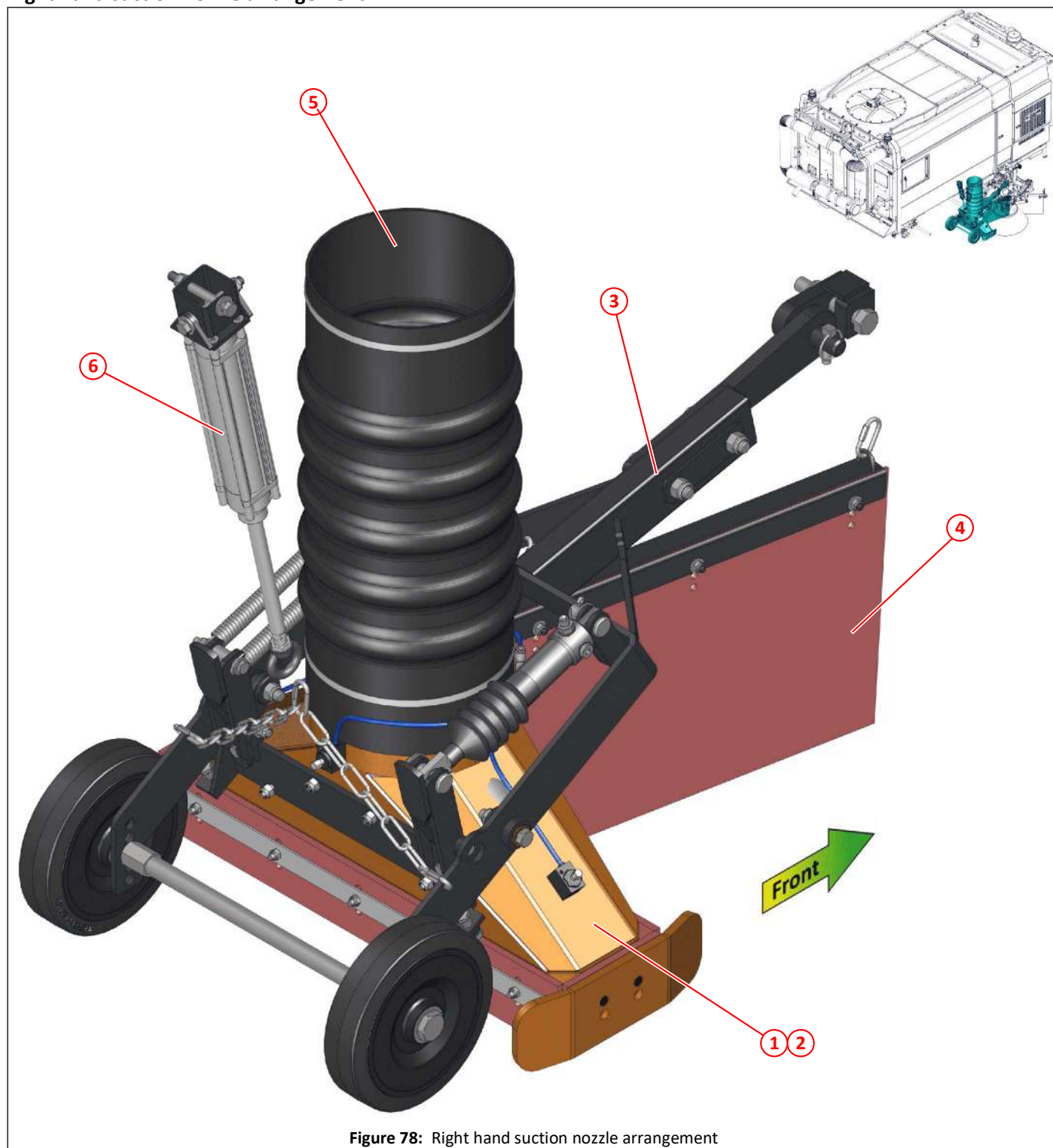

Figure 78: Right hand suction nozzle arrangement

Item	Part No	Qty	Description
①	047107	1	Suction nozzle
②	047988	1	Suction nozzle, PU lined
③	047129	1	Nozzle frame, right hand
④	010247	1	Skirt
⑤	013028	1	Suction hose
⑥	030772	1	Pneumatic cylinder $\varnothing 50 \times 200$, nozzle lift

Right hand suction hose

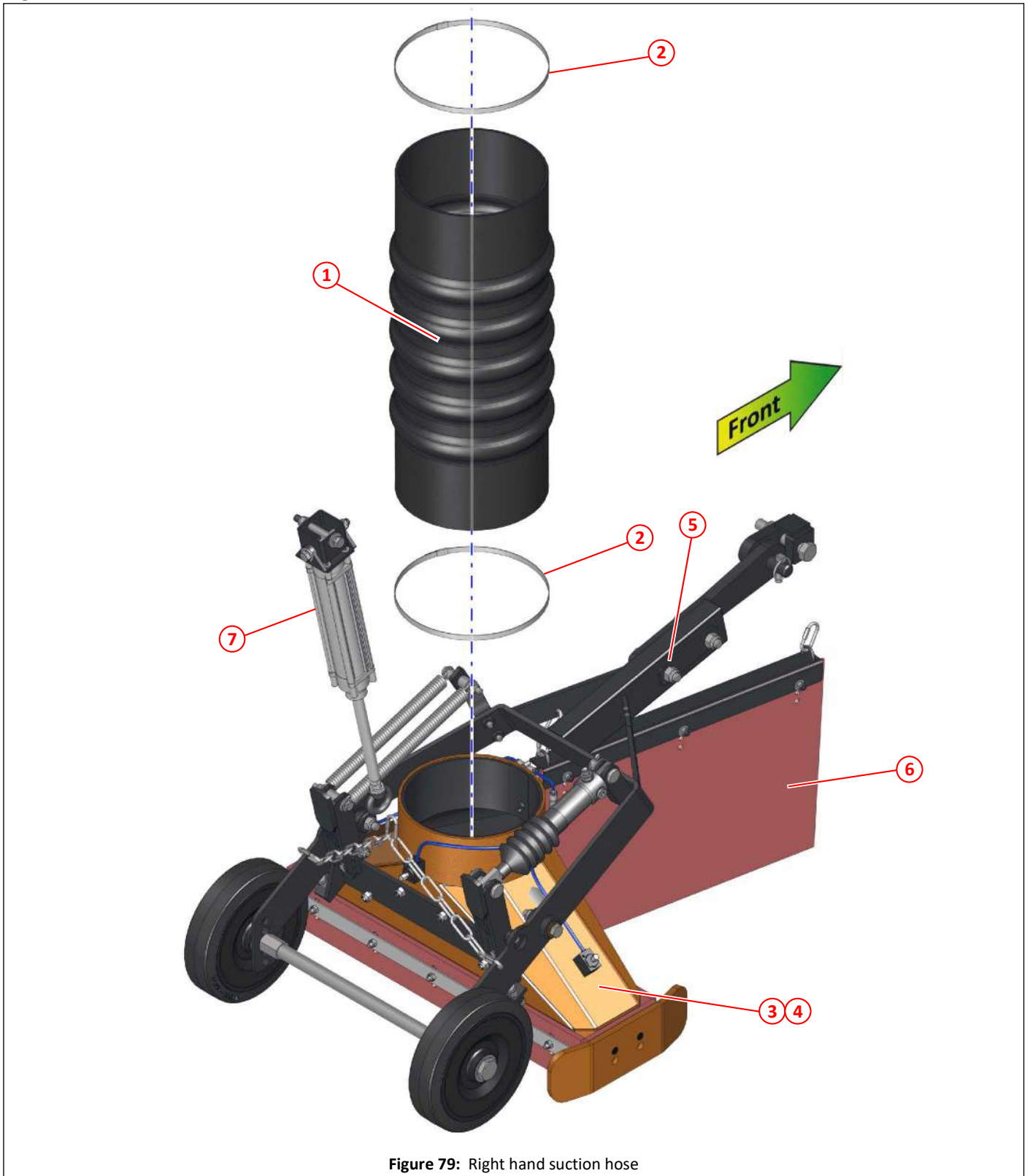

Figure 79: Right hand suction hose

Item	Part No	Qty	Description
①	013028	1	Suction hose
②	012933	1	Jubilee clip No 10.50 (235 - 267)
③	047107	1	Suction nozzle
④	047988	1	Suction nozzle, PU lined
⑤	047128	1	Nozzle frame, left hand
⑥	010247	1	Skirt
⑦	030772	1	Pneumatic cylinder $\varnothing 50 \times 200$, nozzle lift

Right hand suction nozzle lift

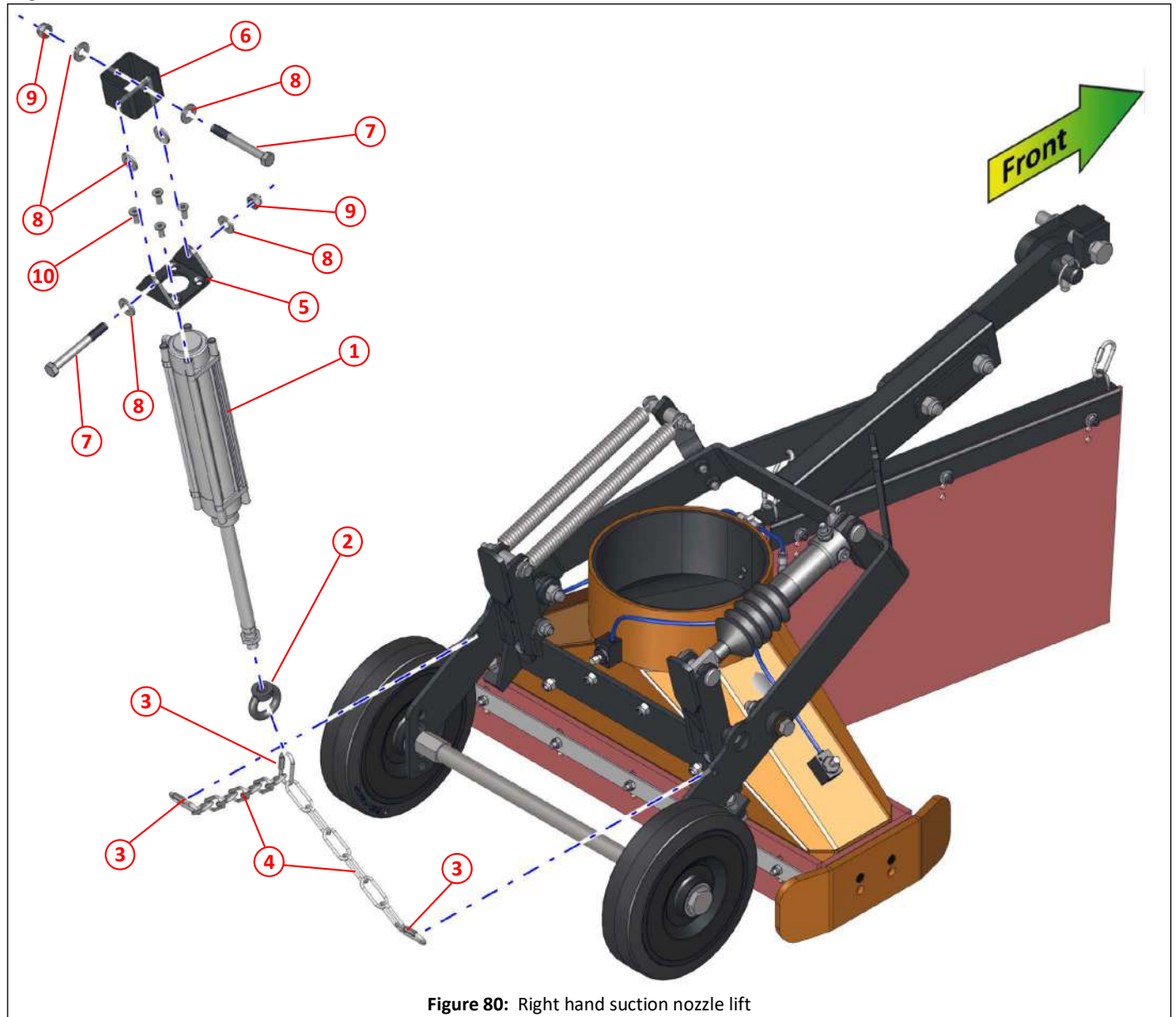

Figure 80: Right hand suction nozzle lift

Item	Part No	Qty	Description
①	030772	1	Pneumatic cylinder $\phi 50 \times 200$, nozzle lift
②	032293	1	Ring nut M16 x 1.5
③	010606	3	Caribiner
④	010525	2	Chain, large link, nozzle lift
⑤	030777	1	Pivot, cylinder mount, nozzle lift
⑥	030776	1	Pivot block, nozzle lift
⑦	011057	2	Bolt M12 x 100
⑧	011096	6	Washer M12
⑨	011077	1	Nyloc nut M12
⑩	000003	4	Screw, socket, countersunk, M8 x 20, plated

Right hand suction nozzle skirt

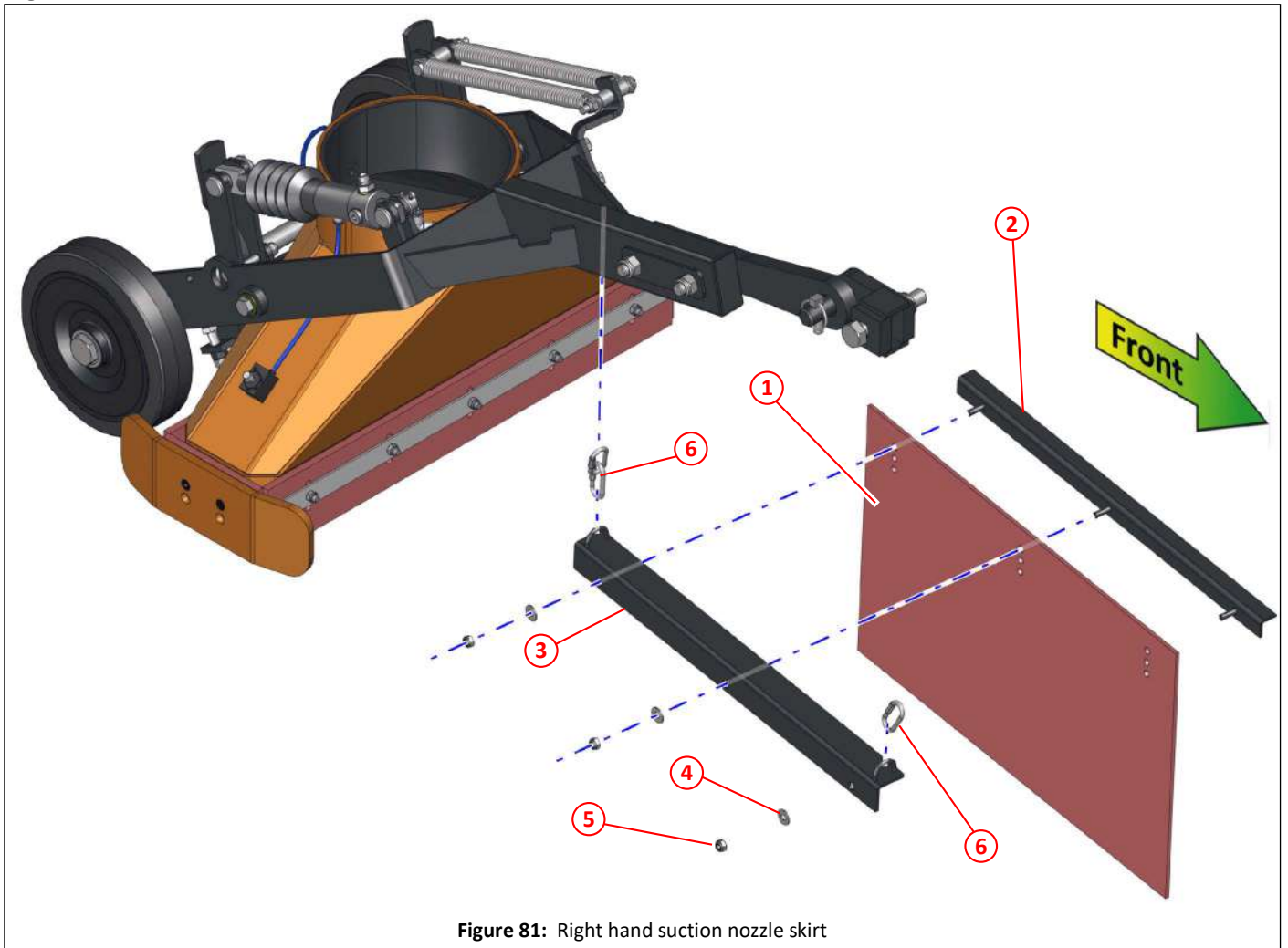

Figure 81: Right hand suction nozzle skirt

Item	Part No	Qty	Description
①	010247	1	Skirt, 3-pitch, heavy duty
②	010275	1	Skirt clamp
③	013145	1	Skirt angle
④	011092	3	Washer M8
⑤	011073	3	Nyloc nut T M8
⑥	010606	3	Caribiner

Right hand suction nozzle frame

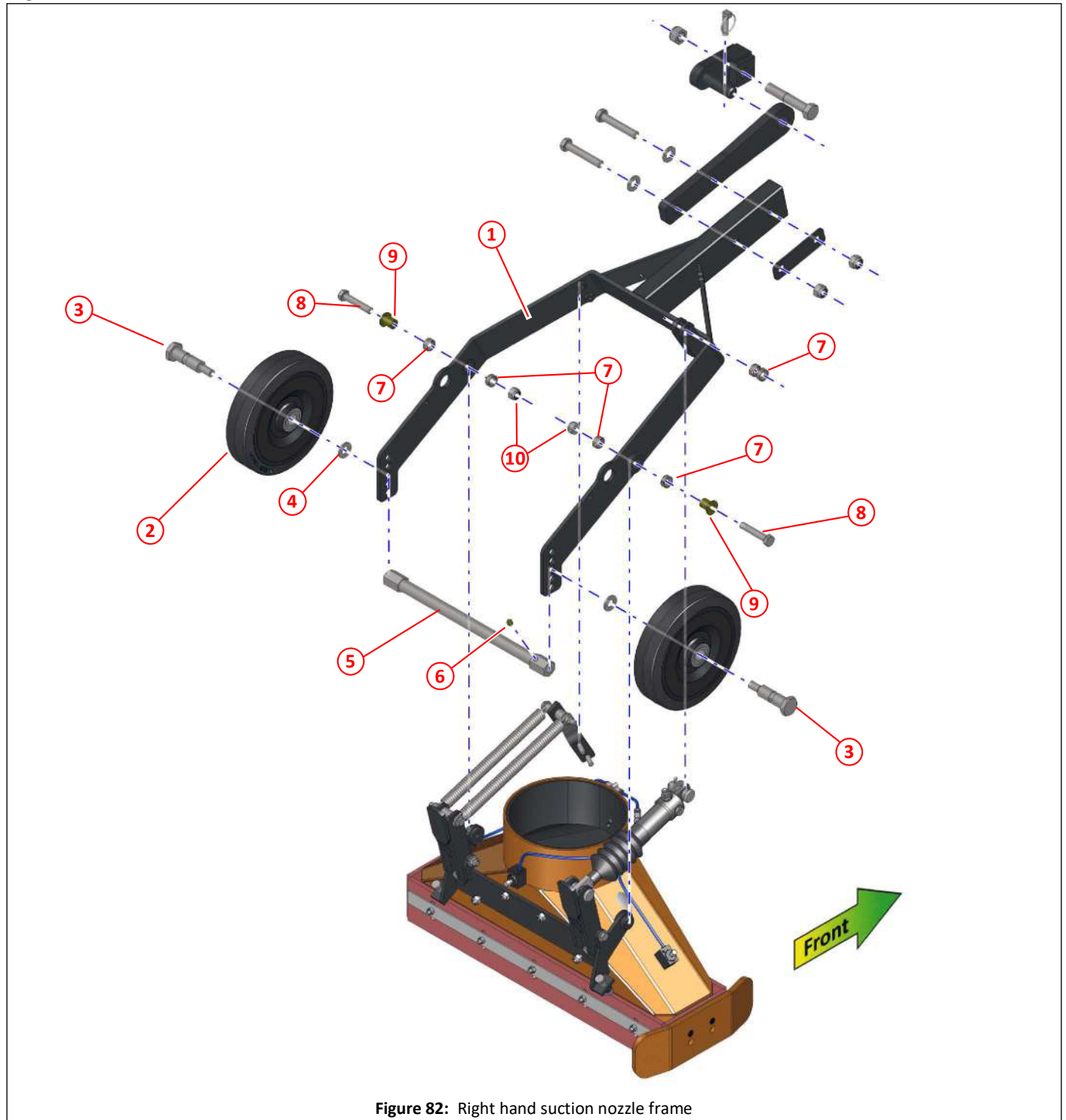

Figure 82: Right hand suction nozzle frame

Item	Part No	Qty	Description
①	047129	1	Nozzle frame, right hand
②	020331	2	Wheel, nozzle, ø250
③	020332	2	Axle bolt, nozzle
④	011135	2	Washer M16
⑤	020333	1	Axle
⑥	010903	1	Grease nipple, straight, 1/8" BSP
⑦	024682	6	Bush ø25 x ø20 x 10
⑧	000351	2	Setscrew M14 x 70
⑨	021416	2	Sleeve, suction nozzle
⑩	011127	2	Nyloc nut T M14

Right hand suction nozzle tow hitch

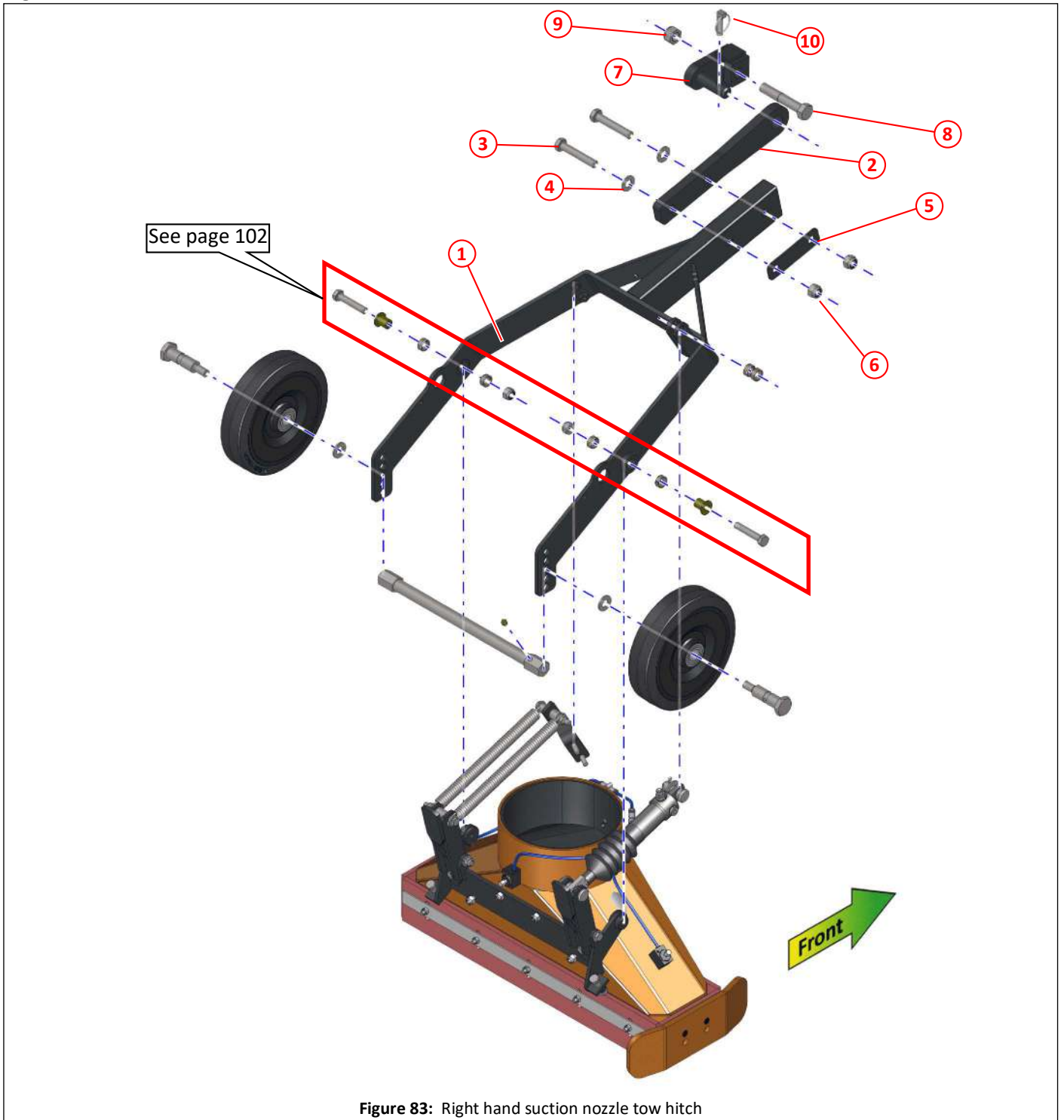

Figure 83: Right hand suction nozzle tow hitch

Item	Part No	Qty	Description
①	047129	1	Nozzle frame, right hand
②	047130	1	Tow hitch, nozzle
③	000043	2	Bolt M16 x 90
④	011135	2	Washer M16
⑤	045492	1	Backing plate
⑥	011060	2	Nyloc nut T M16
⑦	045465	1	Tow pin, nozzle
⑧	011422	1	Bolt M20 x 110
⑨	011082	1	Nyloc nut T M20
⑩	013053	1	Lynch pin

Right hand suction nozzle pivot

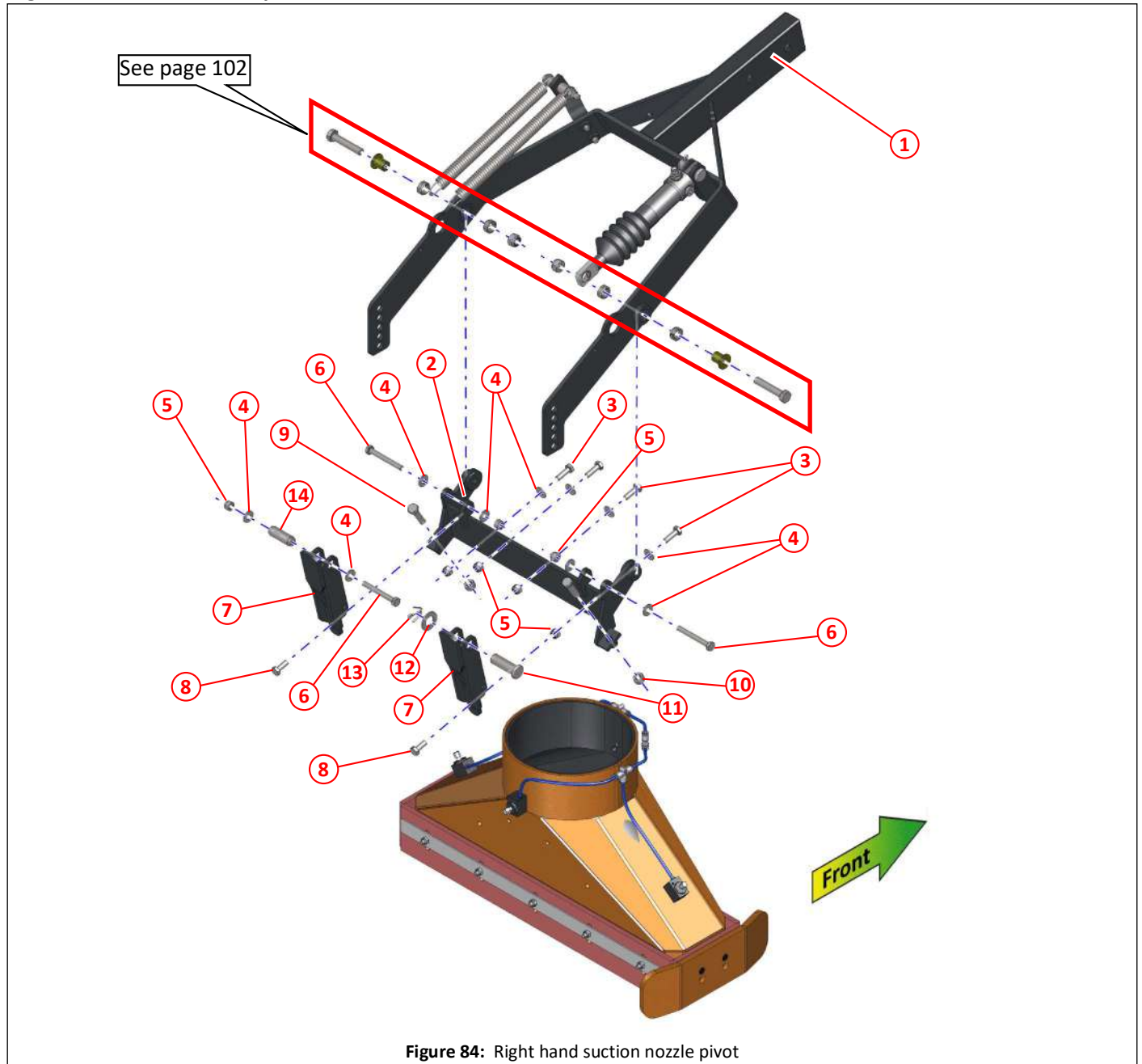

Figure 84: Right hand suction nozzle pivot

Item	Part No	Qty	Description
①	047129	1	Nozzle frame, right hand
②	047114	1	Nozzle pivot
③	011032	4	Setscrew M10 x 30
④	011094	10	Washer M10
⑤	011075	5	Nyloc nut T M10
⑥	011038	3	Bolt M10 x 80
⑦	047116	2	Mounting bracket, spring/ram
⑧	011031	2	Setscrew M10 x 25
⑨	011054	2	Setscrew M12 x 45
⑩	011076	2	Full nut M12
⑪	046749	1	Clevis pin $\varnothing 20 \times 60$
⑫	011102	1	Washer M20
⑬	011122	1	Split pin, $\frac{3}{16}'' \times 1\frac{1}{2}''$
⑭	047136	1	Spring boss $\varnothing 10.5 \times 55$, double stepped

Right hand suction nozzle tilt ram

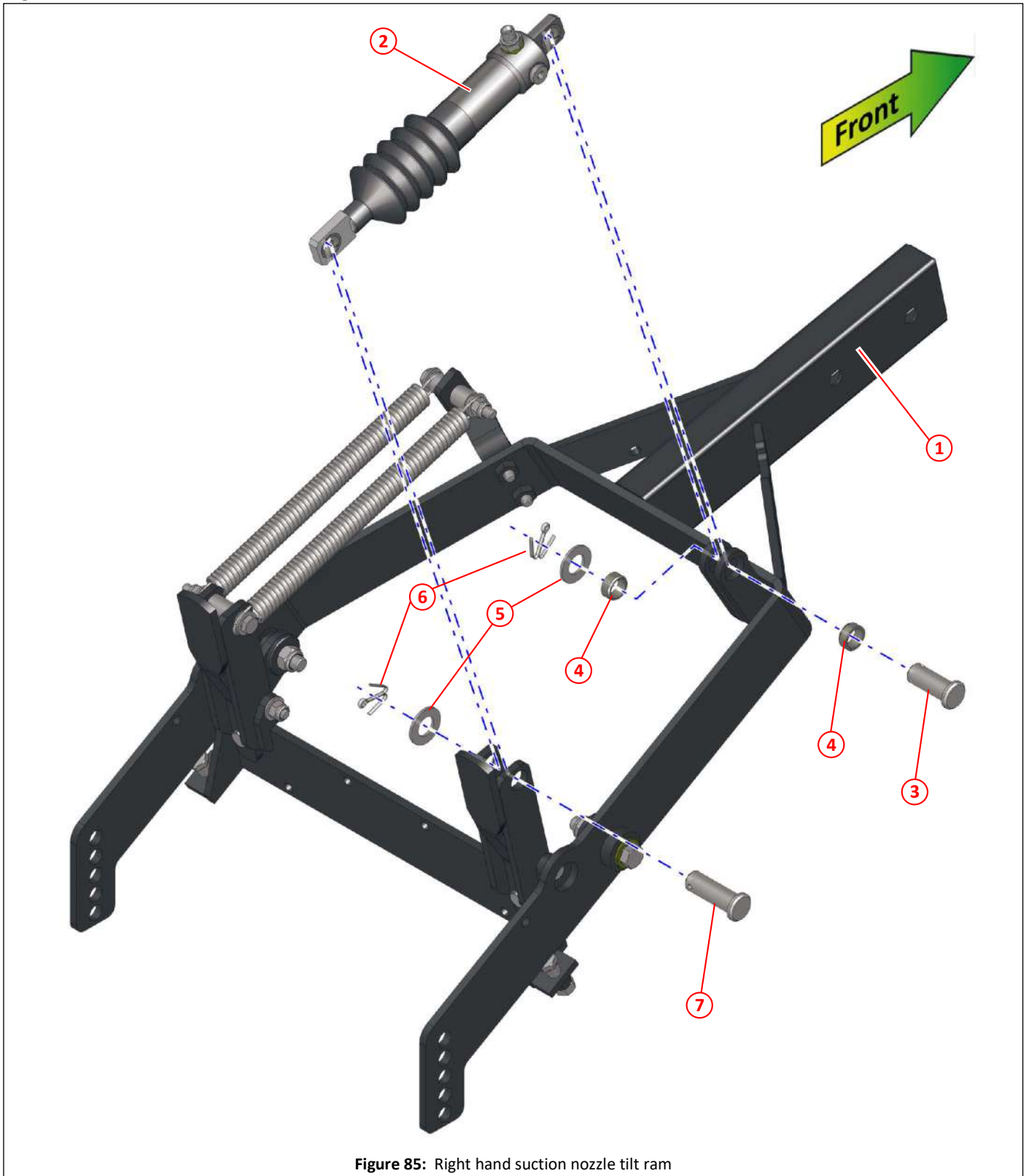

Figure 85: Right hand suction nozzle tilt ram

Item	Part No	Qty	Description
①	047129	1	Nozzle frame, right hand
②	041955	1	Hydraulic ram assembly, nozzle tilt
③	046750	1	Clevis pin $\varnothing 20 \times 50$
④	024682	2	Bush $\varnothing 25 \times \varnothing 20 \times 10$
⑤	011102	2	Washer M20
⑥	011122	2	Split pin, $\frac{3}{16}'' \times 1\frac{1}{2}''$
⑦	046749	1	Clevis pin $\varnothing 20 \times 60$

Right hand suction nozzle tilt return springs

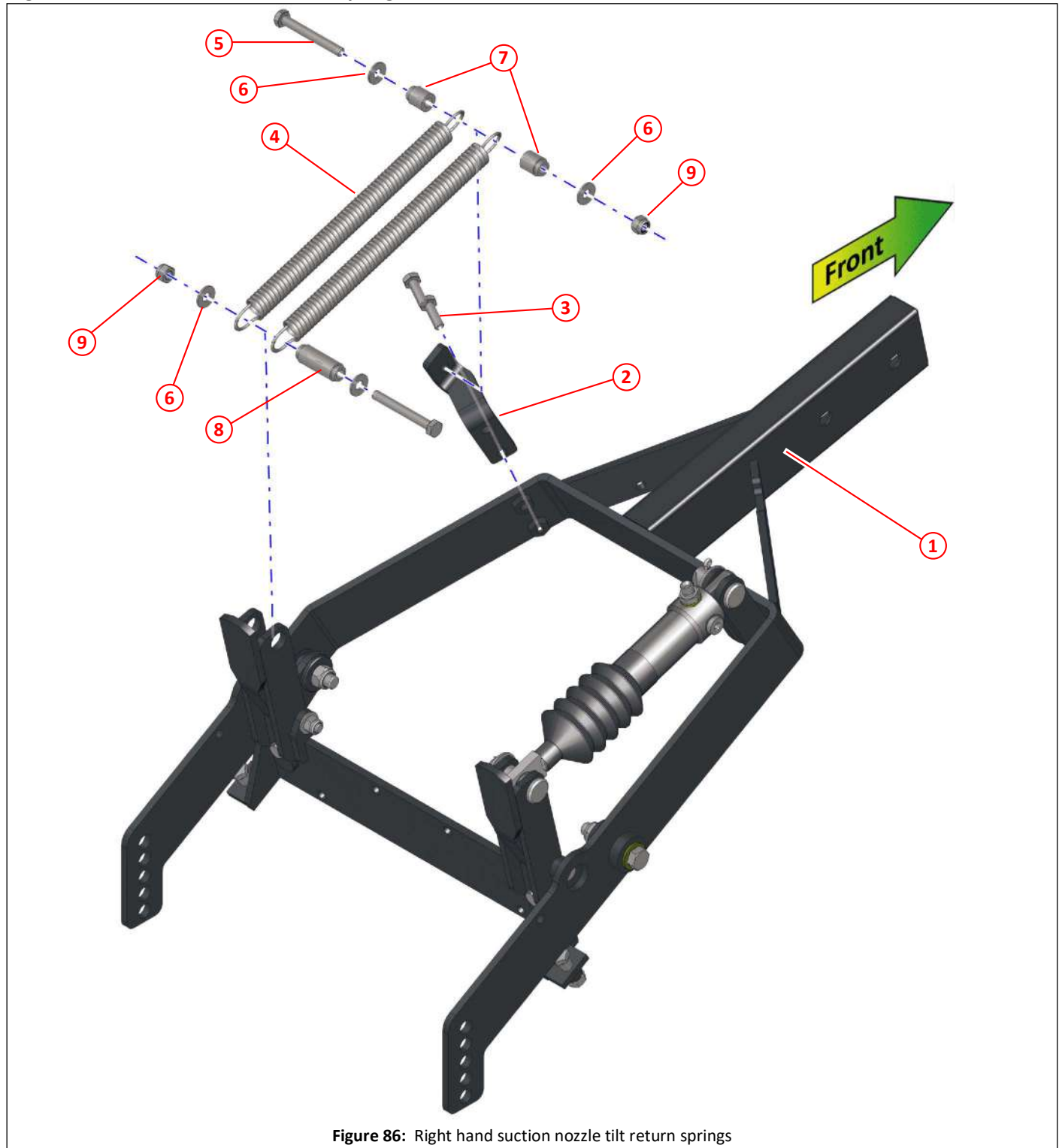

Figure 86: Right hand suction nozzle tilt return springs

Item	Part No	Qty	Description
①	047128	1	Nozzle frame, left hand
②	047126	1	Spring bracket, suction nozzle, left hand
③	011032	2	Setscrew M10 x 30
④	010017	2	Spring
⑤	011038	2	Bolt M10 x 80
⑥	011094	4	Washer M10
⑦	047135	2	Spring boss, $\phi 10.5 \times 23.5$, stepped
⑧	047136	1	Spring boss $\phi 10.5 \times 55$, double stepped
⑨	011075	2	Nyloc nut T M10

Right hand suction nozzle, flaps and skid plate

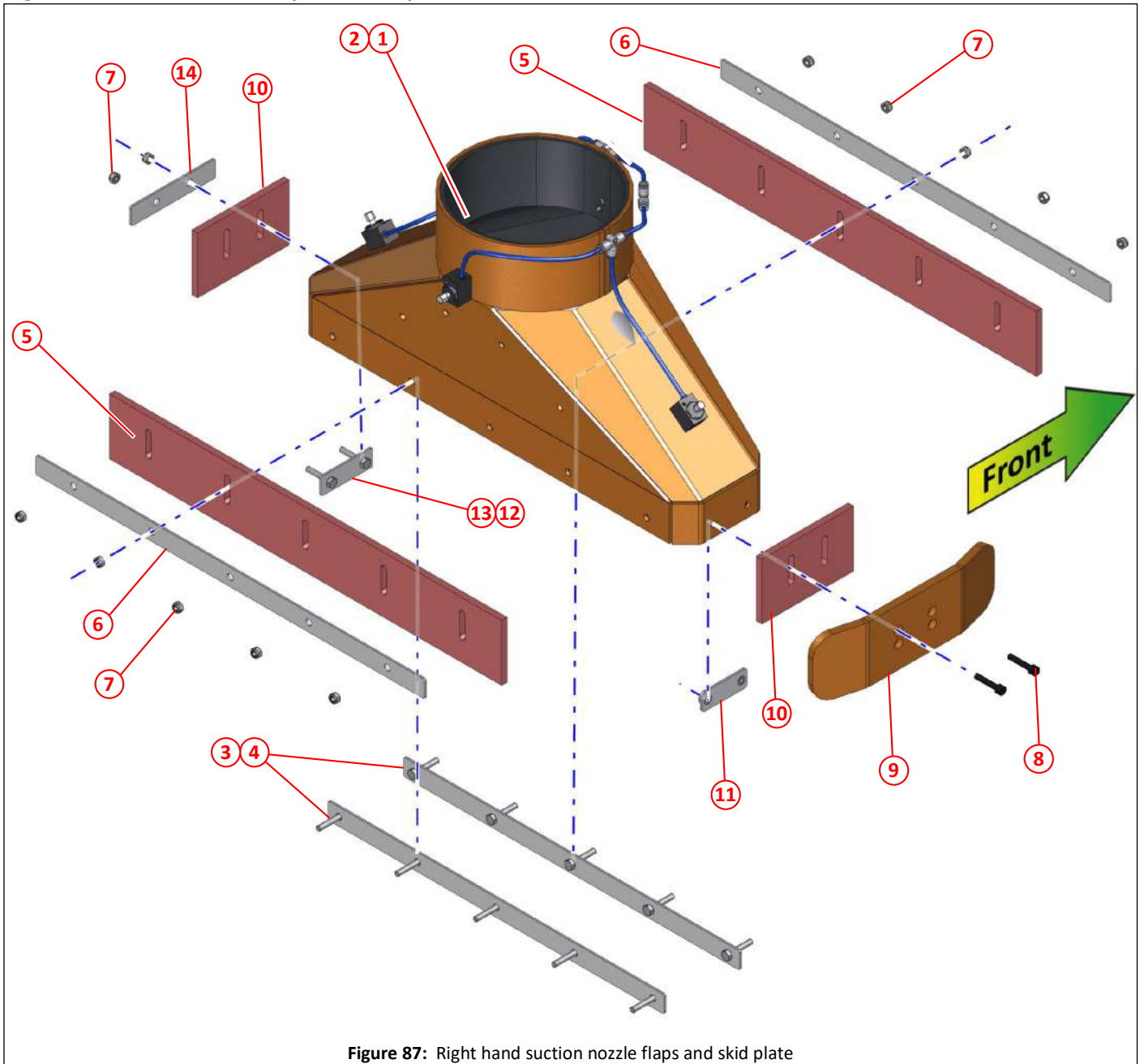

Figure 87: Right hand suction nozzle flaps and skid plate

Item	Part No	Qty	Description
①	047107	1	Suction nozzle
②	047988	1	Suction nozzle, PU lined
③	047110	2	Flap clamp, long
④	048513	2	Flap clamp, long, for PU lined suction nozzle
⑤	047108	2	Flap, long, suction nozzle
⑥	047112	2	Flap clamp strip, long
⑦	011073	12	Nyloc nut T M8
⑧	000096	2	Socket cap screw M8 x 40
⑨	047115	1	Skid plate
⑩	047109	2	Flap, short
⑪	047323	1	Skid plate clamp strip
⑫	047113	1	Flap clamp, short
⑬	048512	1	Flap clamp, short, for PU lined suction nozzle
⑭	047111	1	Flap clamp strip, short

Right hand suction nozzle, water

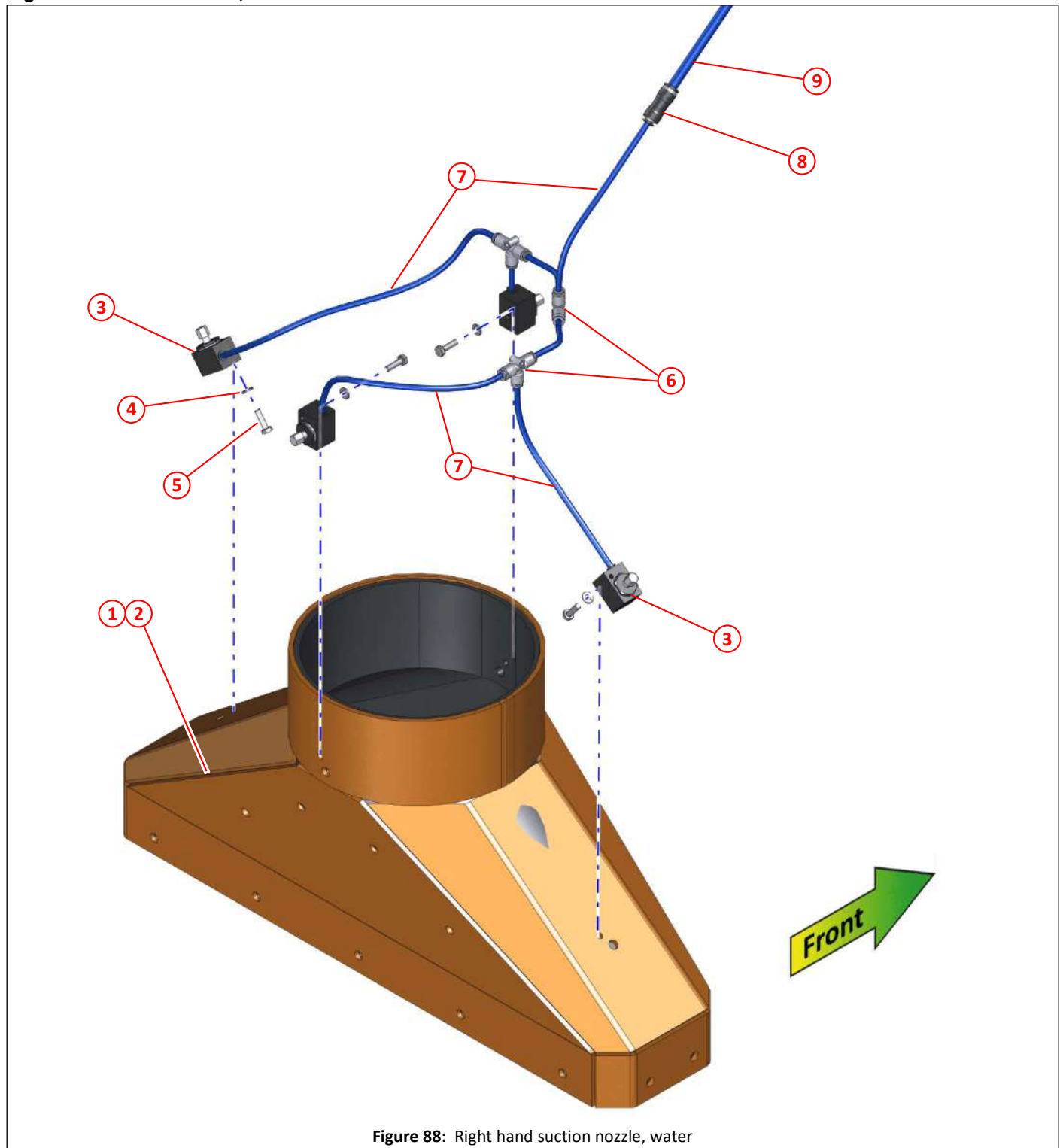

Figure 88: Right hand suction nozzle, water

Item	Part No	Qty	Description
①	047107	1	Suction nozzle
②	047988	1	Suction nozzle, PU lined
③	034342	4	Water nozzle, low pressure
④	011091	4	Spring washer M6
⑤	011067	4	Setscrew M6 x 20
⑥	024647	3	6mm Tee, grey
⑦	035733	6	Blue flexible nylon tubing, ø6mm, (length as required)
⑧	041029	1	Push in adapter, straight, ø10mm to ø6mm
⑨	041031	1	Blue flexible nylon tubing, ø10mm, (length as required)

Left hand suction spigot

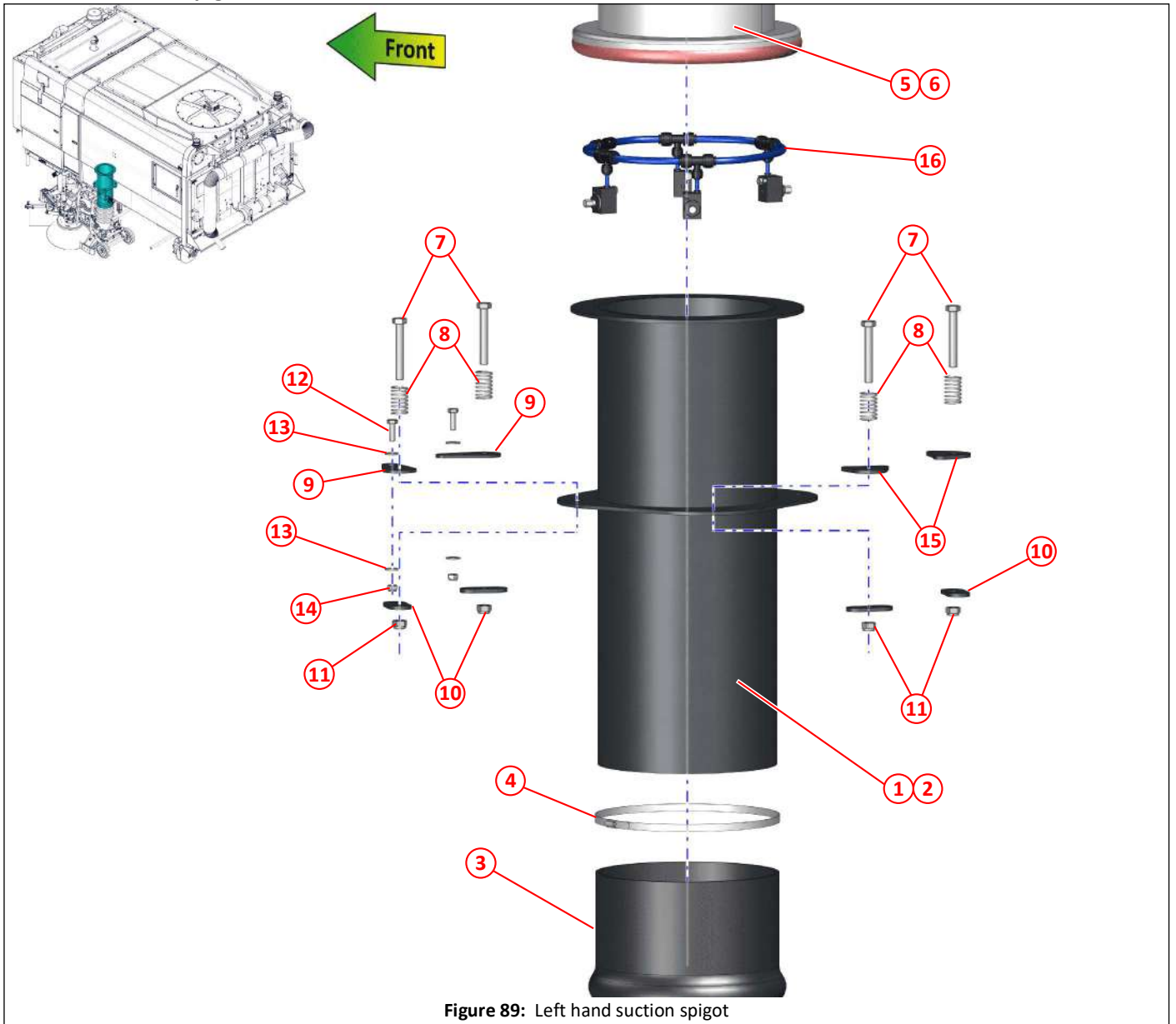

Figure 89: Left hand suction spigot

Item	Part No	Qty	Description	
①	043043	1	Suction spigot	
②	051136	1	Suction spigot, PU lined	
③	013028	1	Suction hose	
④	012933	1	Jubilee clip No 10.50 (235 - 267)	
⑤	047012	1	Deflector tube	
⑥	047989	1	Deflector tube, PU lined	
⑦	000110	4	Bolt M12 x 80	
⑧	042694	4	Spring	
⑨	043392	2	Locking washer, suction spigot	
⑩	039989	4	Washer, suction spigot	
⑪	011077	4	Nyloc nut T M12	
⑫	011011	2	Setscrew M8 x 25	
⑬	011092	4	Washer M8	
⑭	011073	2	Nyloc nut T M8	
⑮	043044	2	Spring seat, suction spigot	
⑯		1	Suction spigot water arrangement	110

Left hand suction spigot water

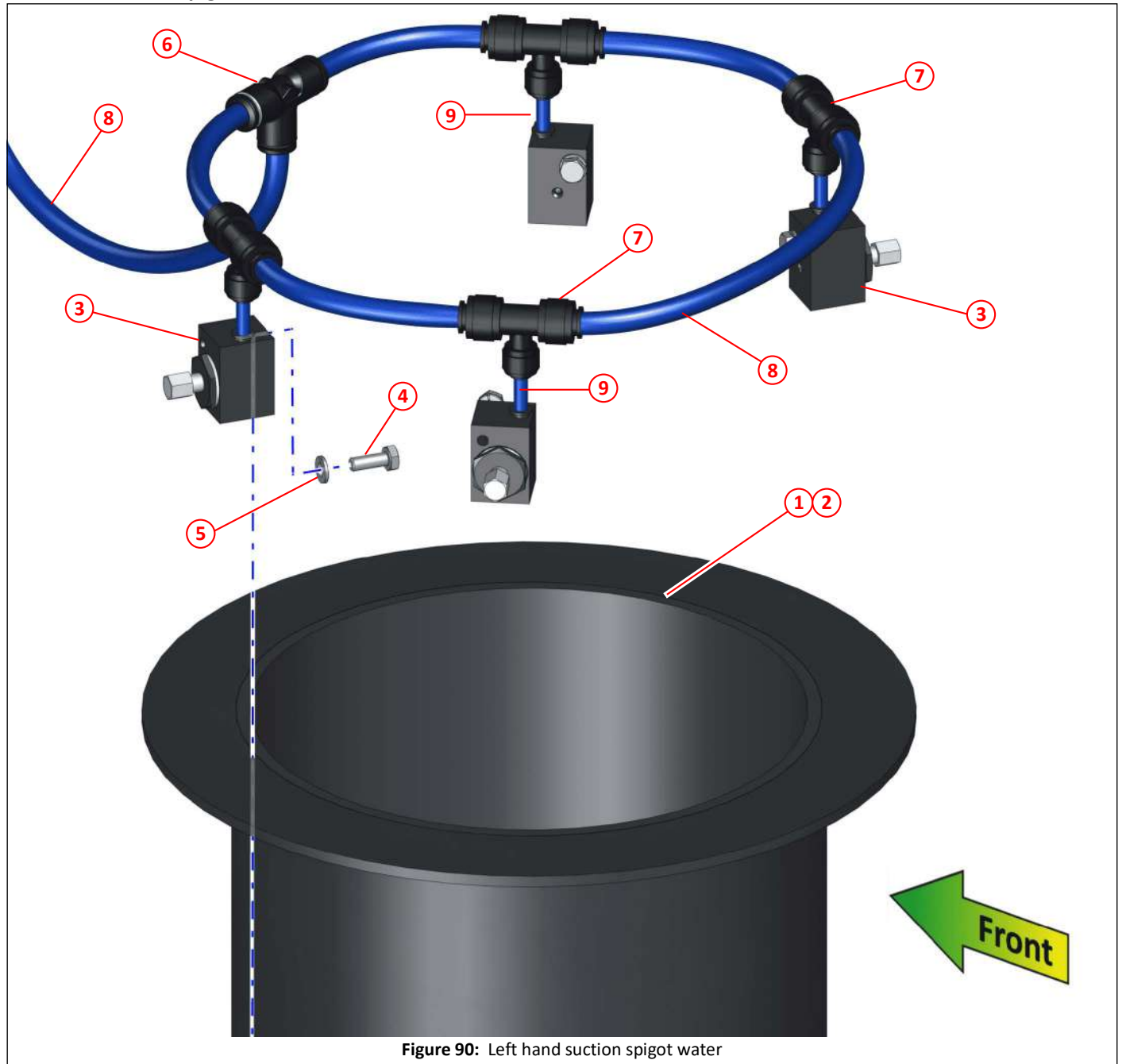
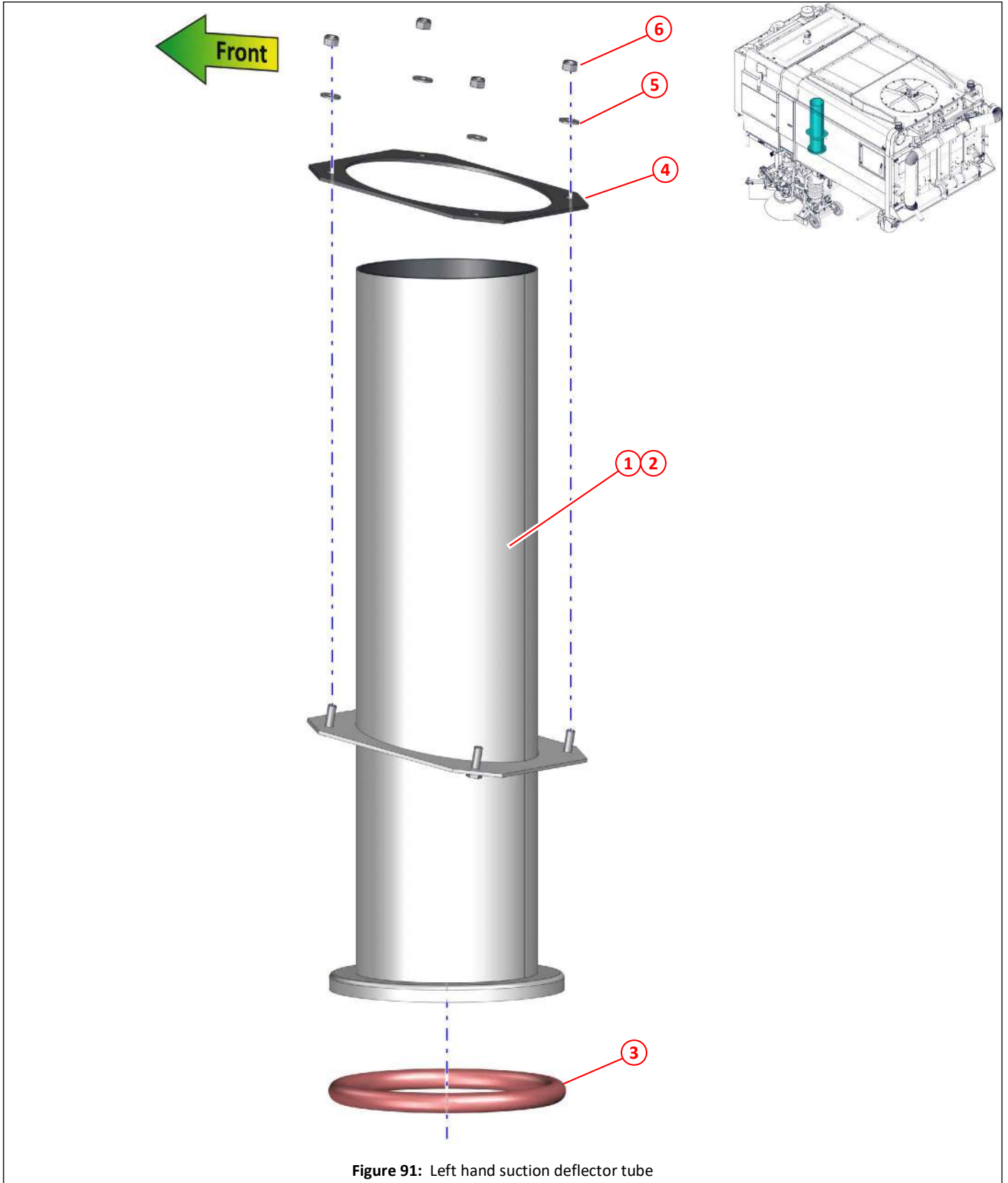

Figure 90: Left hand suction spigot water

Item	Part No	Qty	Description
①	043043	1	Suction spigot
②	051136	1	Suction spigot, PU lined
③	034342	4	Water nozzle, low pressure
④	011001	4	Setscrew M6 x 16
⑤	011091	4	Spring washer M6
⑥	041030	1	Push in tee, equal, $\varnothing 10$
⑦	047778	4	Push in tee, $\varnothing 10 \times \varnothing 10 \times \varnothing 6$, reducer on branch
⑧	041031	6	Blue flexible nylon tubing, $\varnothing 10\text{mm}$, (length as required)
⑨	035733	4	Blue flexible nylon tubing, $\varnothing 6\text{mm}$, (length as required)

Left hand suction deflector tube



Item	Part No	Qty	Description
①	047012	1	Deflector tube
②	047989	1	Deflector tube, PU lined
③	039140	1	Seal, deflector tube
④	044674	1	Gasket, deflector tube
⑤	000277	4	Washer M12, stainless steel
⑥	000275	4	Nyloc nut T M12, stainless steel

Left hand suction deflector

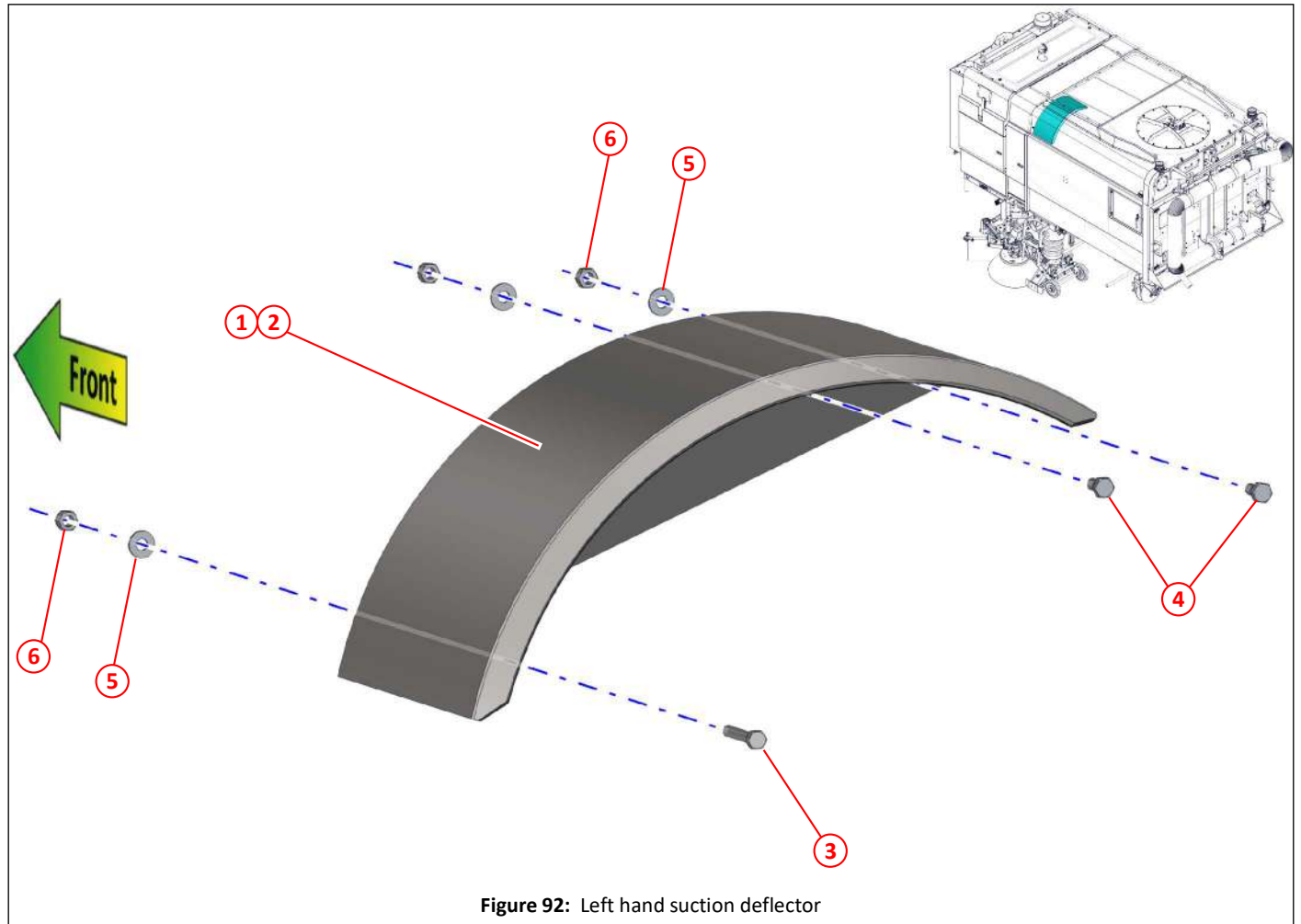

Figure 92: Left hand suction deflector

Item	Part No	Qty	Description
①	022644	1	Suction deflector
②	050823	1	Suction deflector, PU lined
③	000274	1	Bolt M12 x 70, stainless steel
④	000273	2	Setscrew M12 x 25, stainless steel
⑤	000277	3	Washer M12, stainless steel
⑥	000275	3	Nyloc nut T M12, stainless steel

Left hand auto blanking, flap lid and arm

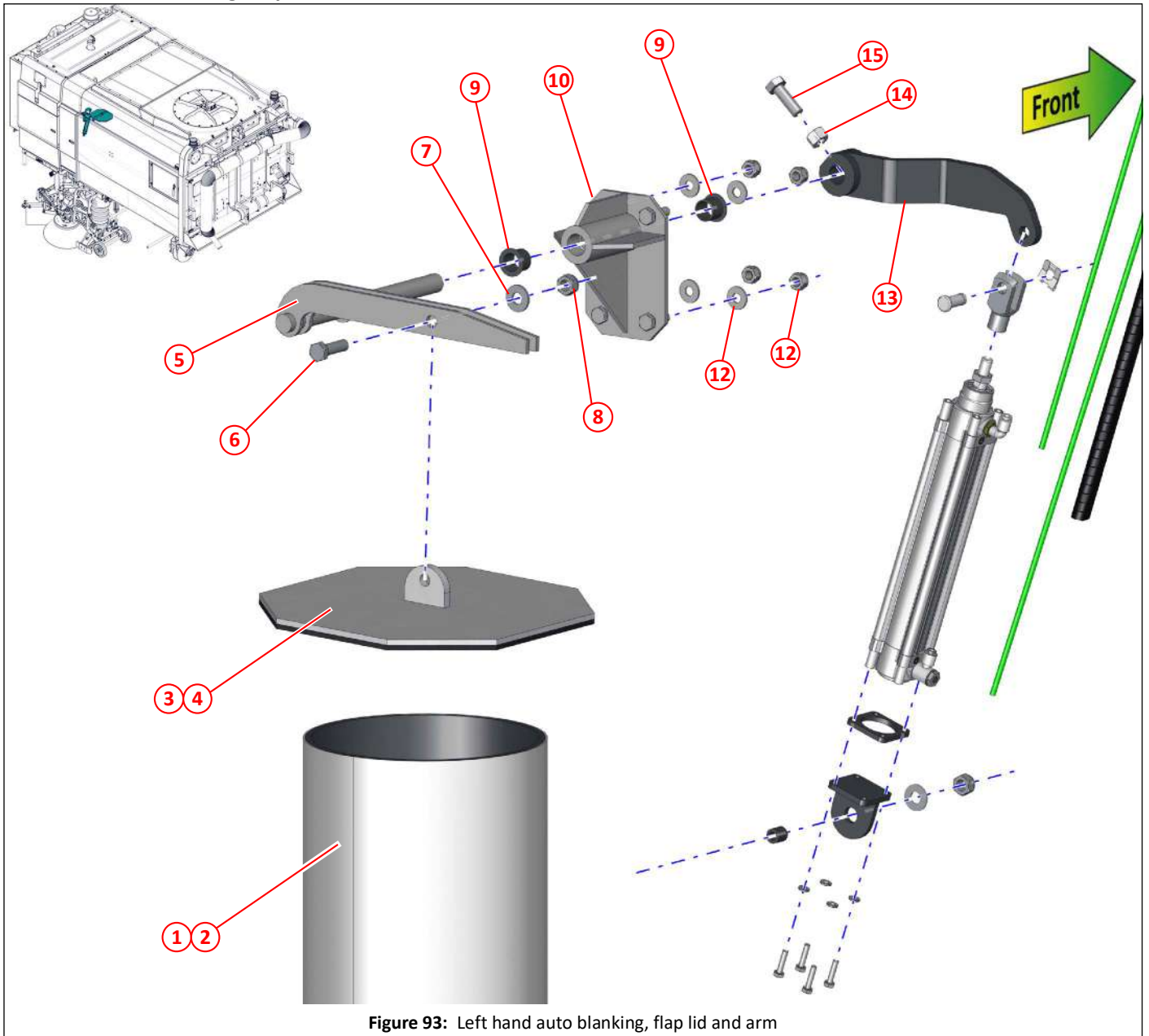

Figure 93: Left hand auto blanking, flap lid and arm

Item	Part No	Qty	Description
①	047012	1	Deflector tube
②	047989	1	Deflector tube, PU lined
③	021514	1	Flap lid
④	050717	1	Flap lid, PU lined
⑤	021517	1	Flap lid arm, left hand
⑥	000278	1	Setscrew M12 x 40
⑦	000277	1	Washer M12, stainless steel
⑧	000275	1	Nyloc nut T M12, stainless steel
⑨	013488	2	Bush
⑩	021164	1	Flap pivot, auto blanking
⑪	011094	4	Washer M10
⑫	011075	4	Nyloc nut T M10
⑬	034396	1	Flap arm, left hand
⑭	000279	1	Full nut M12 x 1.25, stainless steel
⑮	000276	1	Setscrew M12 x 1.25 x 35, stainless steel

Left hand auto blanking, pneumatic cylinder

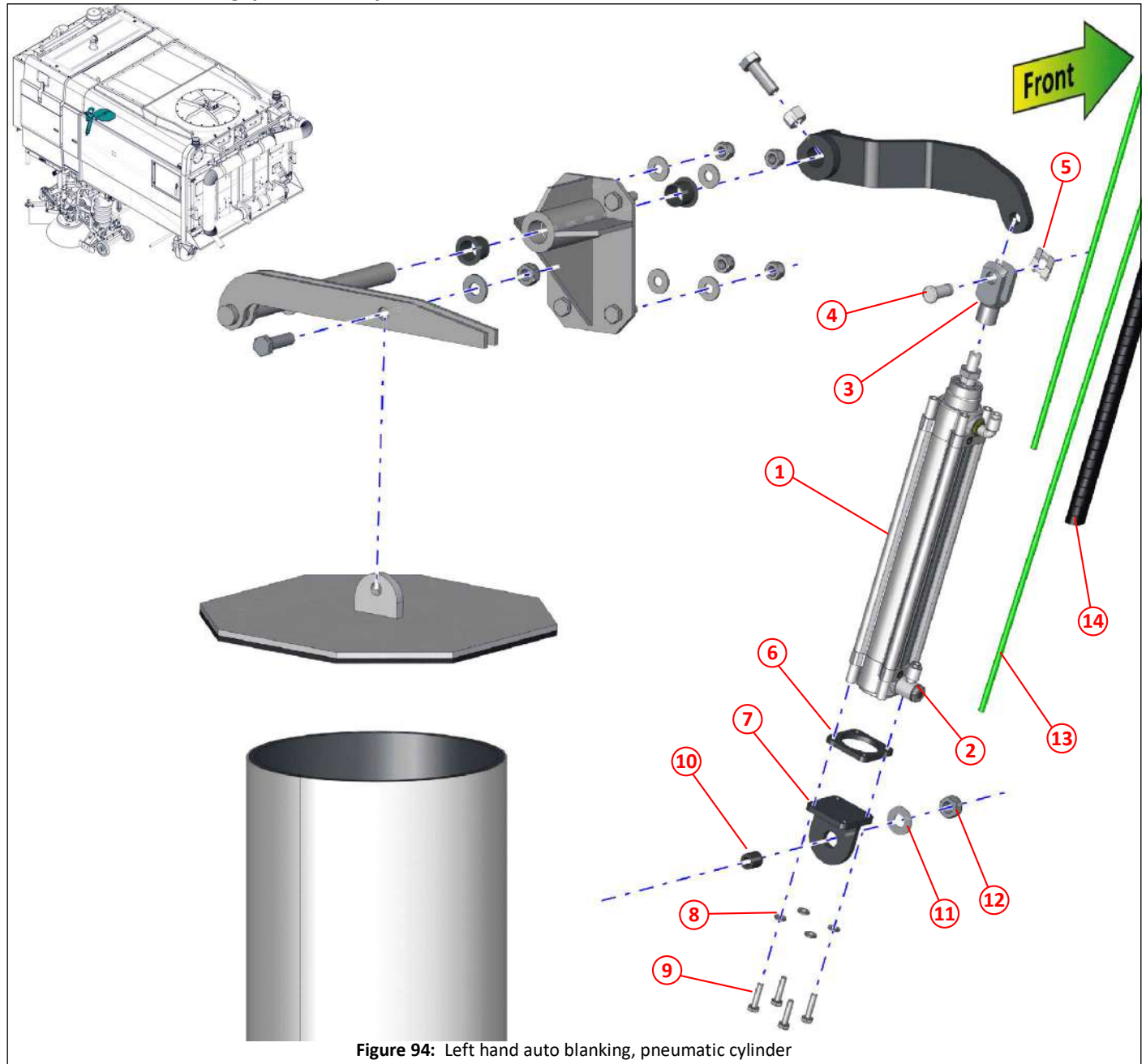

Figure 94: Left hand auto blanking, pneumatic cylinder

Item	Part No	Qty	Description
①	021467	1	Pneumatic cylinder $\phi 40 \times 200$
②	021158	1	Pneumatic flow regulator
③	014469	1	Clevis, M12, pneumatic cylinder
④	023270	1	Clevis $\phi 12$
⑤	023269	1	Safety fastener $\phi 12$
⑥	045502	1	Spacer, auto blanking cylinder
⑦	014457	1	Cylinder mount
⑧	011091	4	Spring washer M6
⑨	011087	4	Setscrew M6 x 25
⑩	010950	1	Hose $\frac{3}{8}$ " , cut to 20mm
⑪	000277	1	Washer M12
⑫	000275	1	Nyloc nut T M12, stainless steel
⑬	024650	2	$\phi 6$ mm green air pipe, length as required
⑭	004210	1	Flexible, conduit, split $\phi 21$

Right hand suction spigot

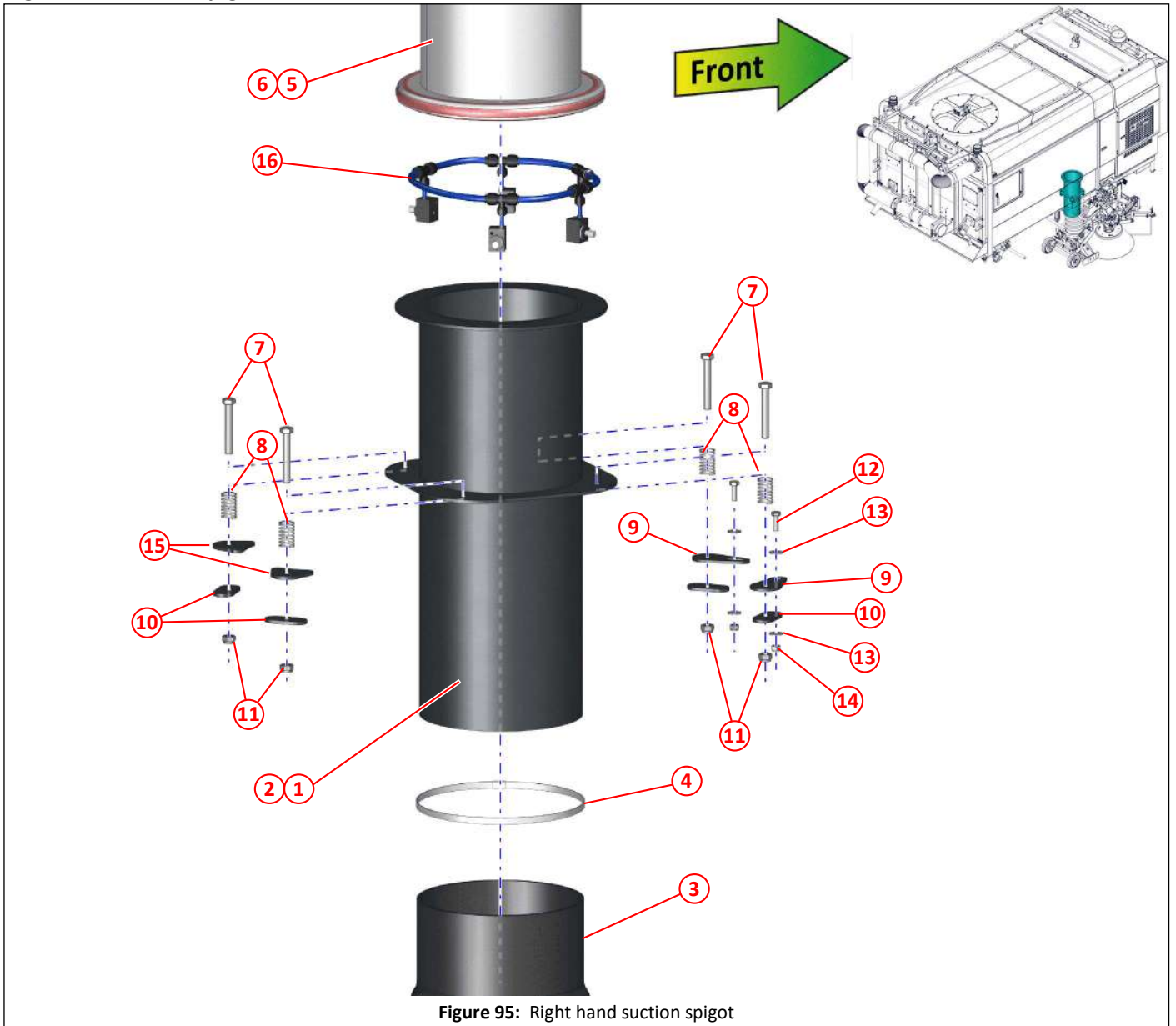

Figure 95: Right hand suction spigot

Item	Part No	Qty	Description	
①	043043	1	Suction spigot	
②	051136	1	Suction spigot, PU lined	
③	013028	1	Suction hose	
④	012933	1	Jubilee clip No 10.50 (235 - 267)	
⑤	047012	1	Deflector tube	
⑥	047989	1	Deflector tube, PU lined	
⑦	000110	4	Bolt M12 x 80	
⑧	042694	4	Spring	
⑨	043392	2	Locking washer, suction spigot	
⑩	039989	4	Washer, suction spigot	
⑪	011077	4	Nyloc nut T M12	
⑫	011011	2	Setscrew M8 x 25	
⑬	011092	4	Washer M8	
⑭	011073	2	Nyloc nut T M8	
⑮	043044	2	Spring seat, suction spigot	
⑯		1	Suction spigot water arrangement	110

Right hand suction spigot water

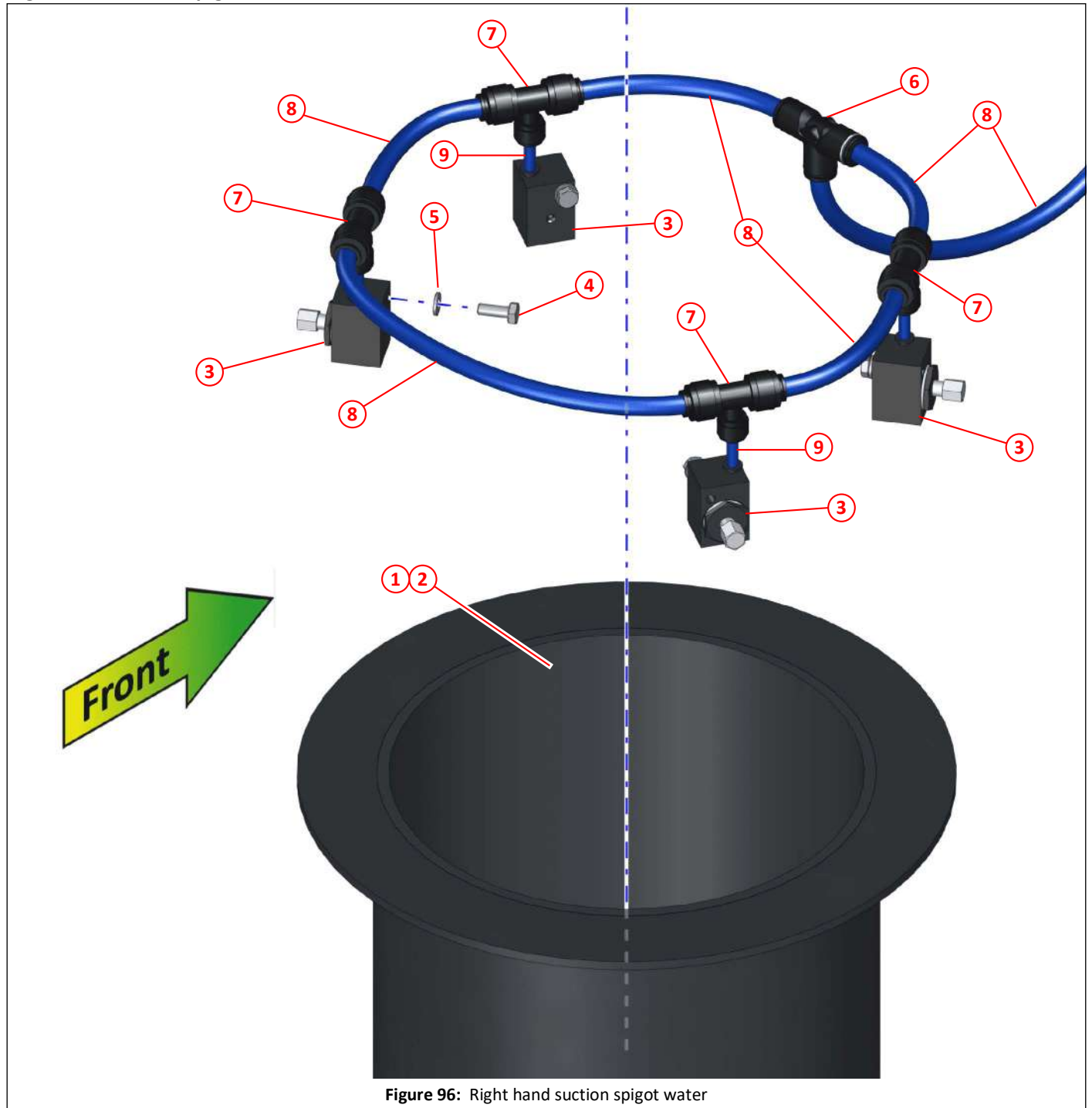

Figure 96: Right hand suction spigot water

Item	Part No	Qty	Description
①	043043	1	Suction spigot
②	051136	1	Suction spigot, PU lined
③	034342	4	Water nozzle, low pressure
④	011001	4	Setscrew M6 x 16
⑤	011091	4	Spring washer M6
⑥	041030	1	Push in tee, equal, $\varnothing 10$
⑦	047778	4	Push in tee, $\varnothing 10 \times \varnothing 10 \times \varnothing 6$, reducer on branch
⑧	041031	6	Blue flexible nylon tubing, $\varnothing 10\text{mm}$, (length as required)
⑨	035733	4	Blue flexible nylon tubing, $\varnothing 6\text{mm}$, (length as required)

Right hand suction deflector tube

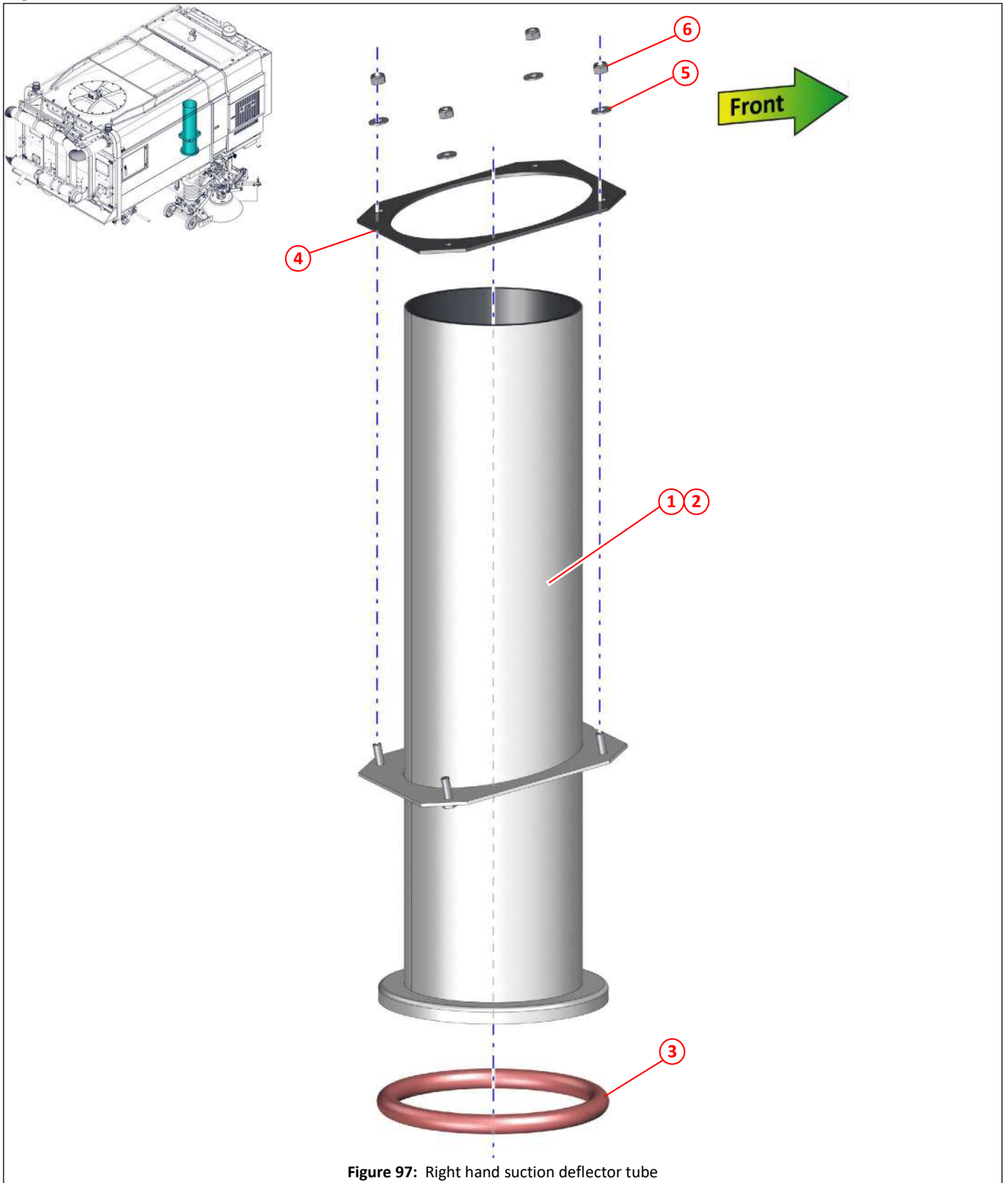

Figure 97: Right hand suction deflector tube

Item	Part No	Qty	Description
①	047012	1	Deflector tube
②	047989	1	Deflector tube, PU lined
③	039140	1	Seal, deflector tube
④	044674	1	Gasket, deflector tube
⑤	000277	4	Washer M12, stainless steel
⑥	000275	4	Nyloc nut T M12, stainless steel

Right hand suction deflector

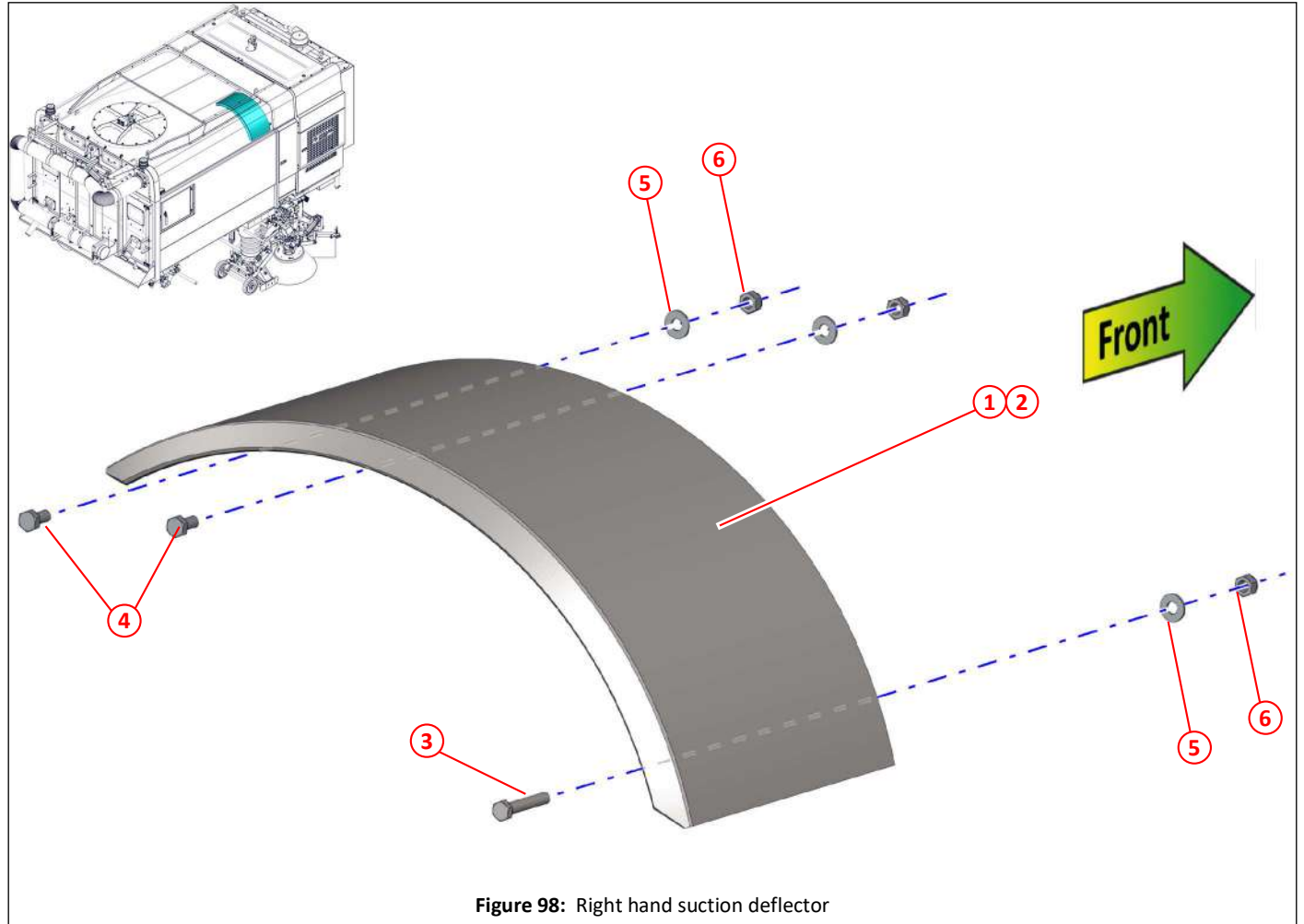

Figure 98: Right hand suction deflector

Item	Part No	Qty	Description
①	022644	1	Suction deflector
②	050823	1	Suction deflector, PU lined
③	000274	1	Bolt M12 x 70, stainless steel
④	000273	2	Setscrew M12 x 25, stainless steel
⑤	000277	3	Washer M12, stainless steel
⑥	000275	3	Nyloc nut T M12, stainless steel

Right hand auto blanking, flap lid and arm

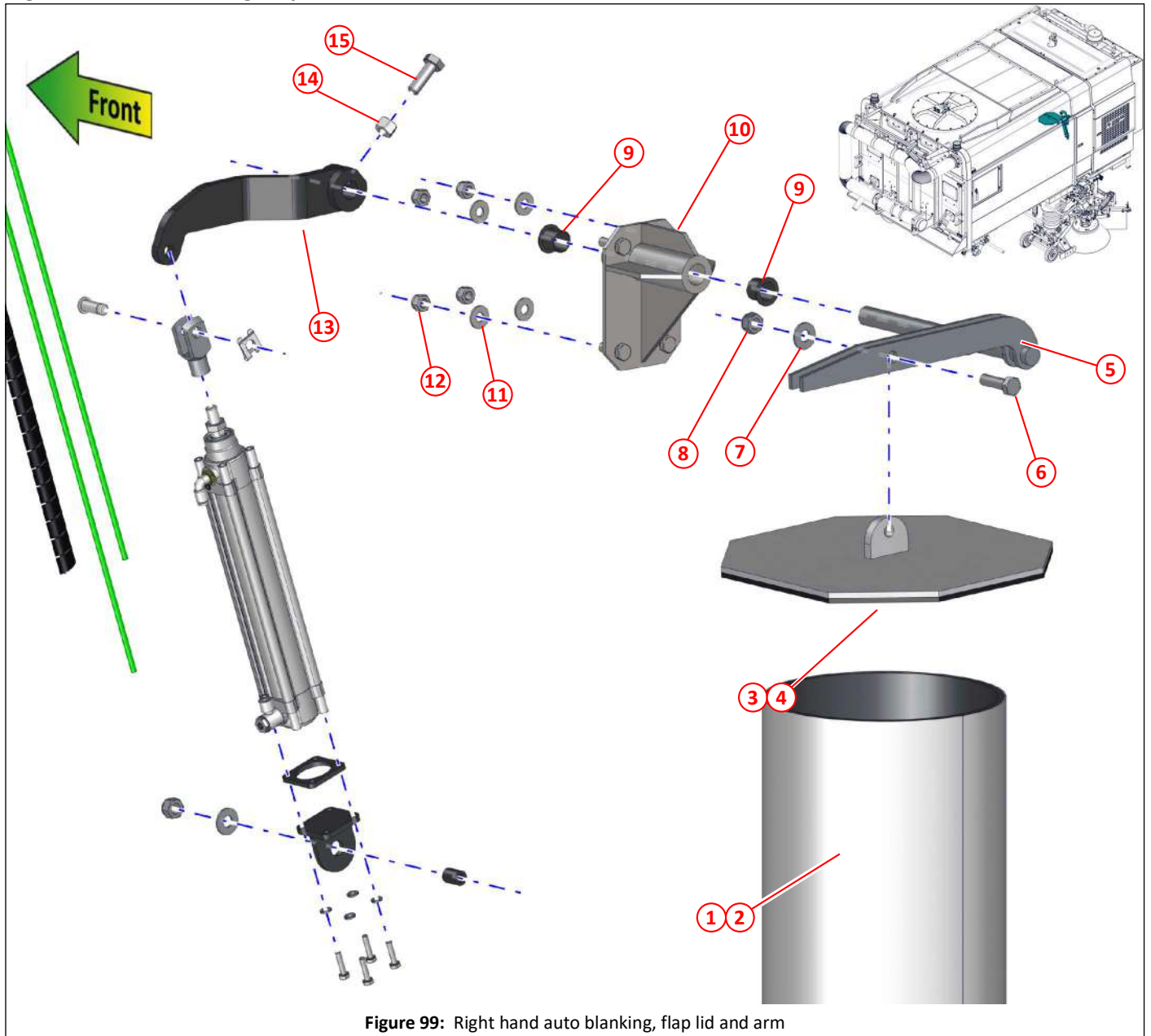

Figure 99: Right hand auto blanking, flap lid and arm

Item	Part No	Qty	Description
①	047012	1	Deflector tube
②	047989	1	Deflector tube, PU lined
③	021514	1	Flap lid
④	050717	1	Flap lid, PU lined
⑤	021517	1	Flap lid arm, left hand
⑥	000278	1	Setscrew M12 x 40
⑦	000277	1	Washer M12, stainless steel
⑧	000275	1	Nyloc nut T M12, stainless steel
⑨	013488	2	Bush
⑩	021164	1	Flap pivot, auto blanking
⑪	011094	4	Washer M10
⑫	011075	4	Nyloc nut T M10
⑬	034396	1	Flap arm, right hand
⑭	000279	1	Full nut M12 x 1.25, stainless steel
⑮	000276	1	Setscrew M12 x 1.25 x 35, stainless steel

Right hand auto blanking, pneumatic cylinder

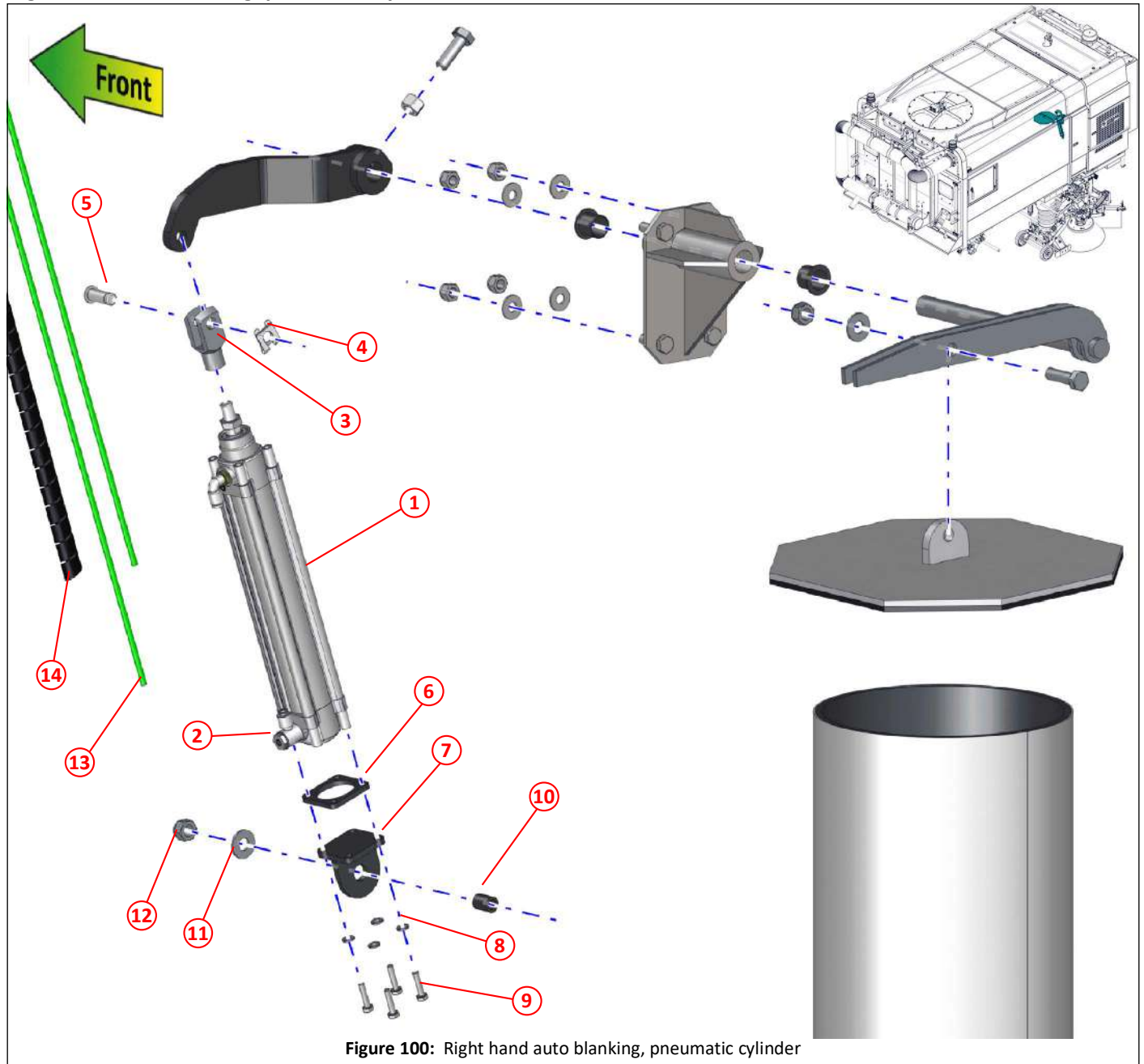

Figure 100: Right hand auto blanking, pneumatic cylinder

Item	Part No	Qty	Description
①	021467	1	Pneumatic cylinder $\phi 40 \times 200$
②	021158	1	Pneumatic flow regulator
③	014469	1	Clevis, M12, pneumatic cylinder
④	023270	1	Clevis $\phi 12$
⑤	023269	1	Safety fastener $\phi 12$
⑥	045502	1	Spacer, auto blanking cylinder
⑦	014457	1	Cylinder mount
⑧	011091	4	Spring washer M6
⑨	011087	4	Setscrew M6 x 25
⑩	010950	1	Hose $\frac{3}{8}$ " , cut to 20mm
⑪	000277	1	Washer M12
⑫	000275	1	Nyloc nut T M12, stainless steel
⑬	024650	2	$\phi 6$ mm green air pipe, length as required
⑭	004210	1	Flexible, conduit, split $\phi 21$

Deflector swing plate

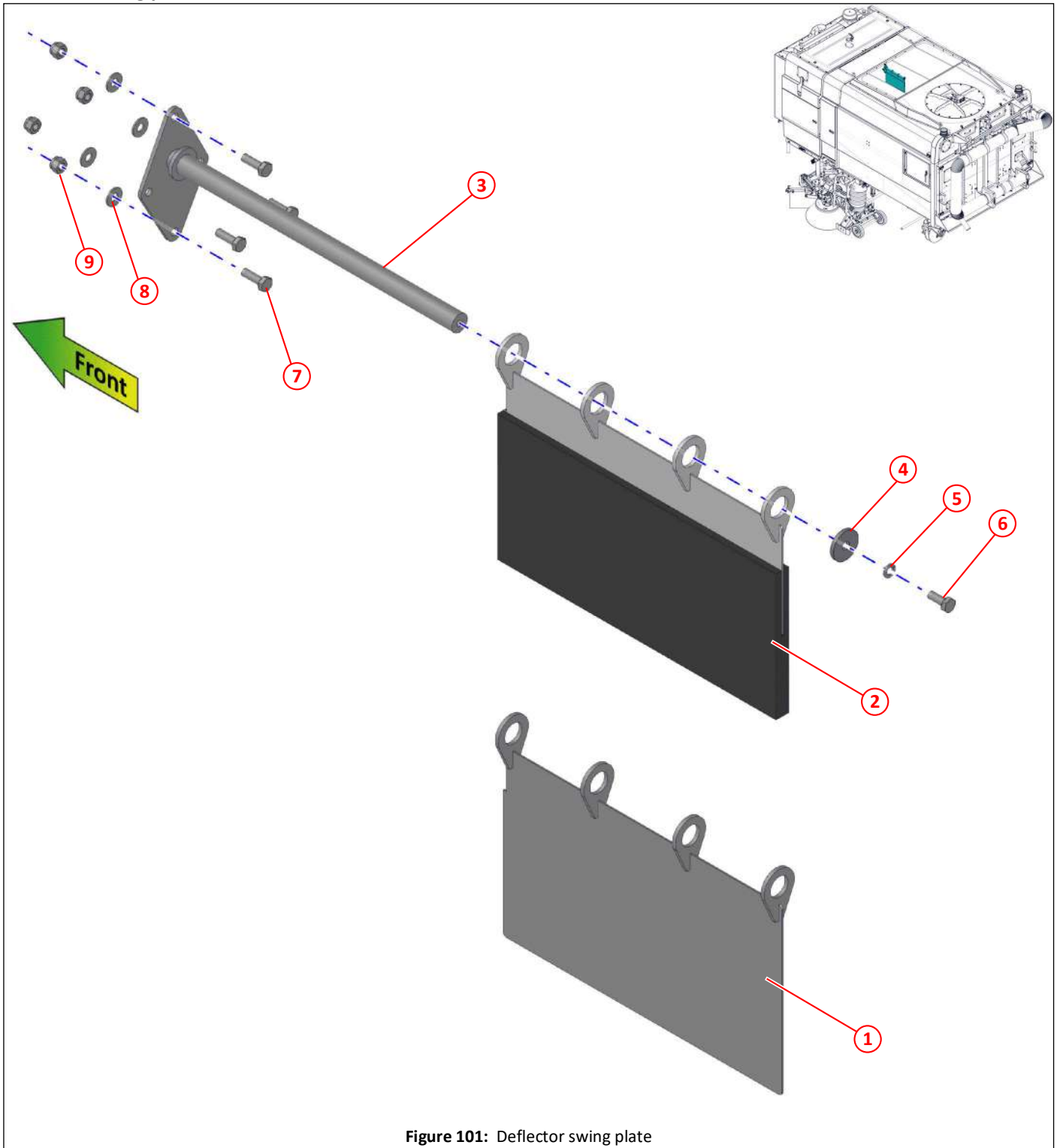
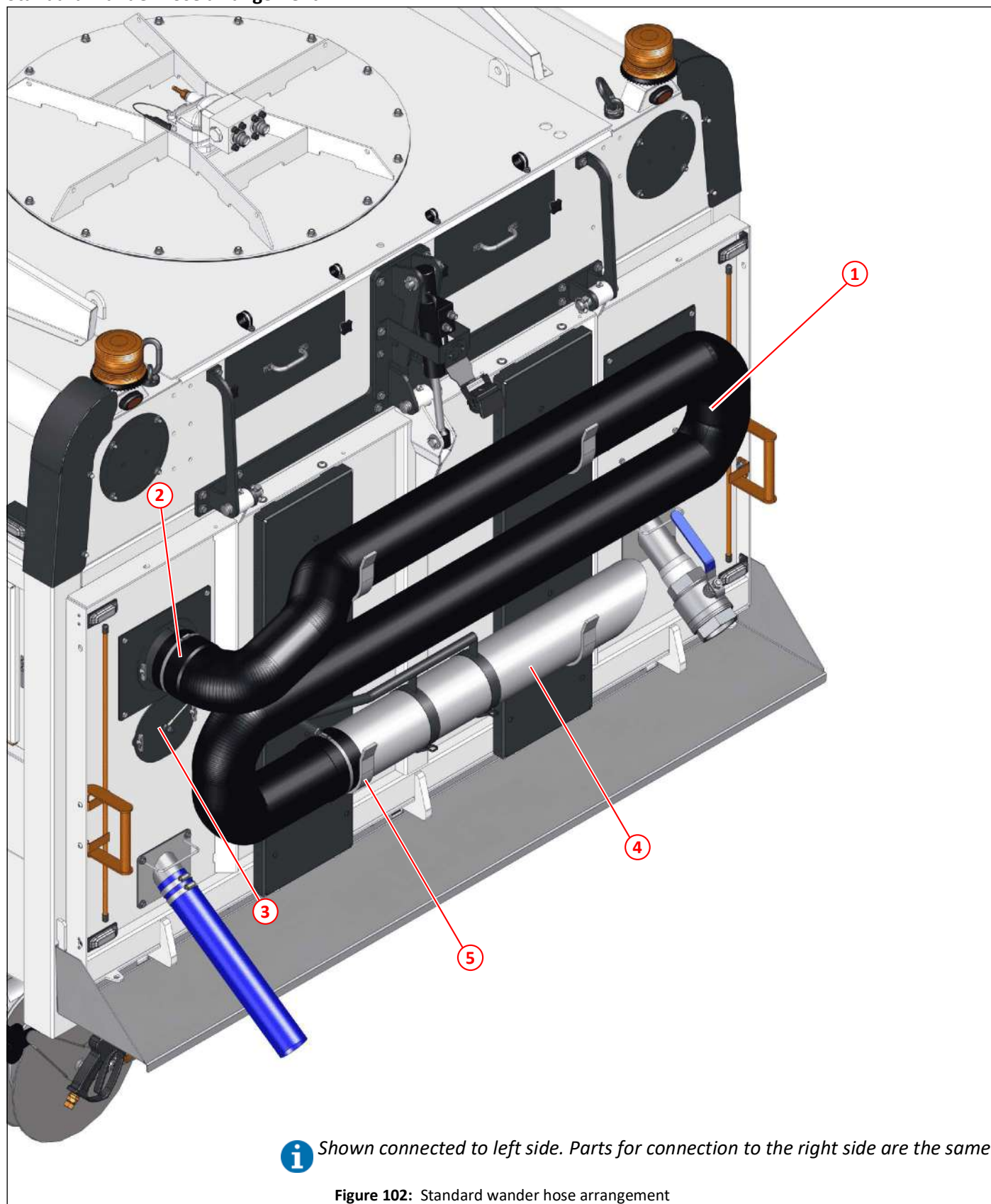

Figure 101: Deflector swing plate

Item	Part No	Qty	Description
①	044618	1	Deflector plate
②	044606	1	Deflector plate, PU lined
③	044605	1	Mounting bar, deflector plate
④	030537	1	Washer $\phi 10.5 \times \phi 40 \times 5$
⑤	011095	1	Spring washer M10
⑥	011031	1	Setscrew M10 x 25
⑦	011032	4	Setscrew M10 x 30
⑧	011094	4	Washer M10
⑨	011075	4	Nyloc nut T M10

Standard wander hose arrangement



i Shown connected to left side. Parts for connection to the right side are the same.

Figure 102: Standard wander hose arrangement

Item	Part No	Qty	Description
①	010119	1	Hose, wander, 3m, flexible
②	012488	1	Wander hose spigot
③	012486	1	Blanking cap plate
④	010587	1	Suction tube, wander hose
⑤	010245	4	Hose hook, wander hose

Standard wander hose

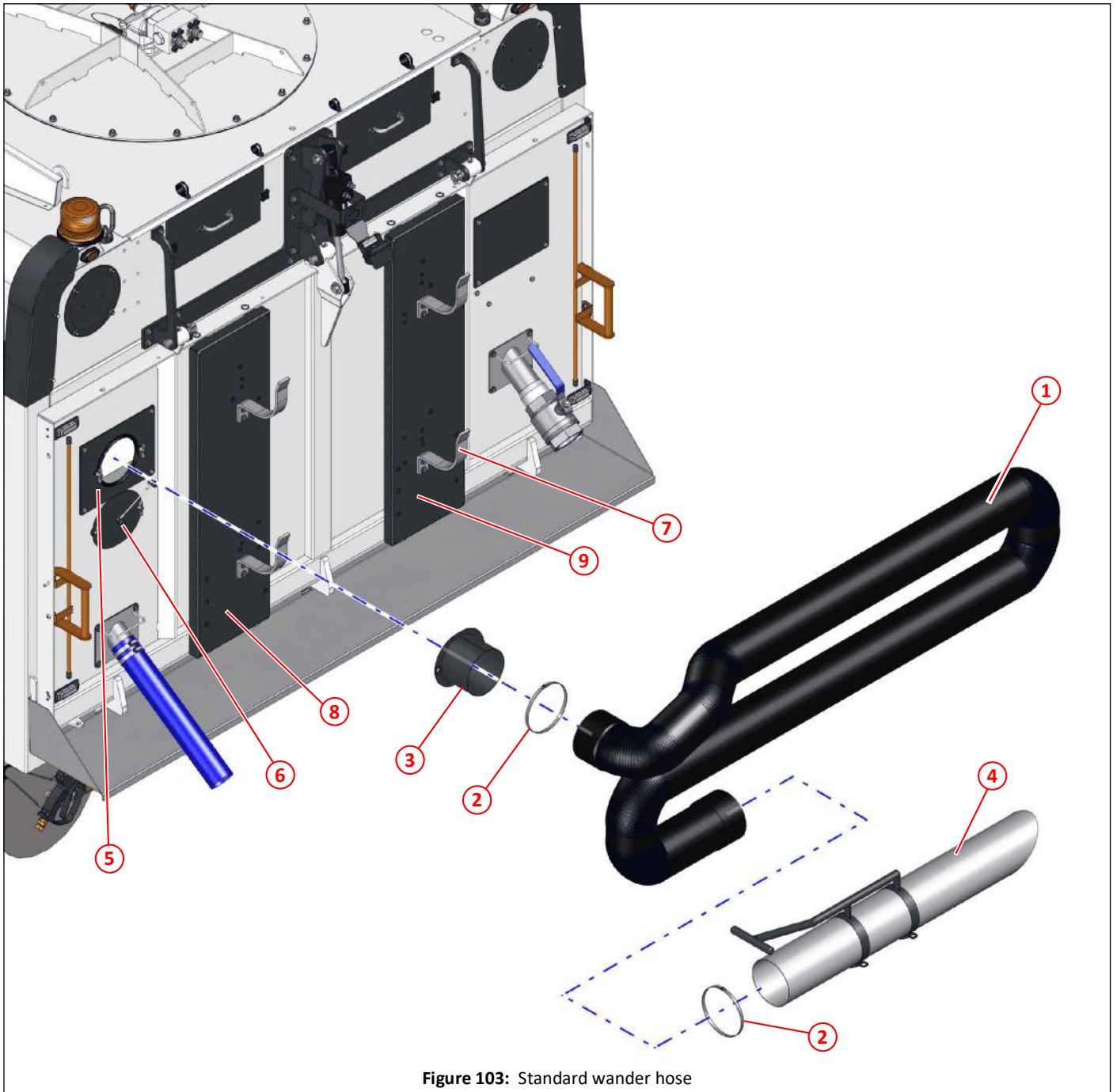

Figure 103: Standard wander hose

Item	Part No	Qty	Description
①	010119	1	Hose, wander, 3m, flexible
②	010519	2	Jubilee clip, No 7 (ø135-ø165)
③	012488	1	Wander hose spigot
④	010587	1	Suction tube, wander hose
⑤	023009	1	Mounting adapter, wander hose
⑥	012486	1	Blanking cap plate
⑦	010245	4	Hose hook, wander hose
⑧	046982	1	Options bracket, left hand, rear door
⑨	046983	1	Options bracket, right hand, rear door

Hose attachment, standard wander hose

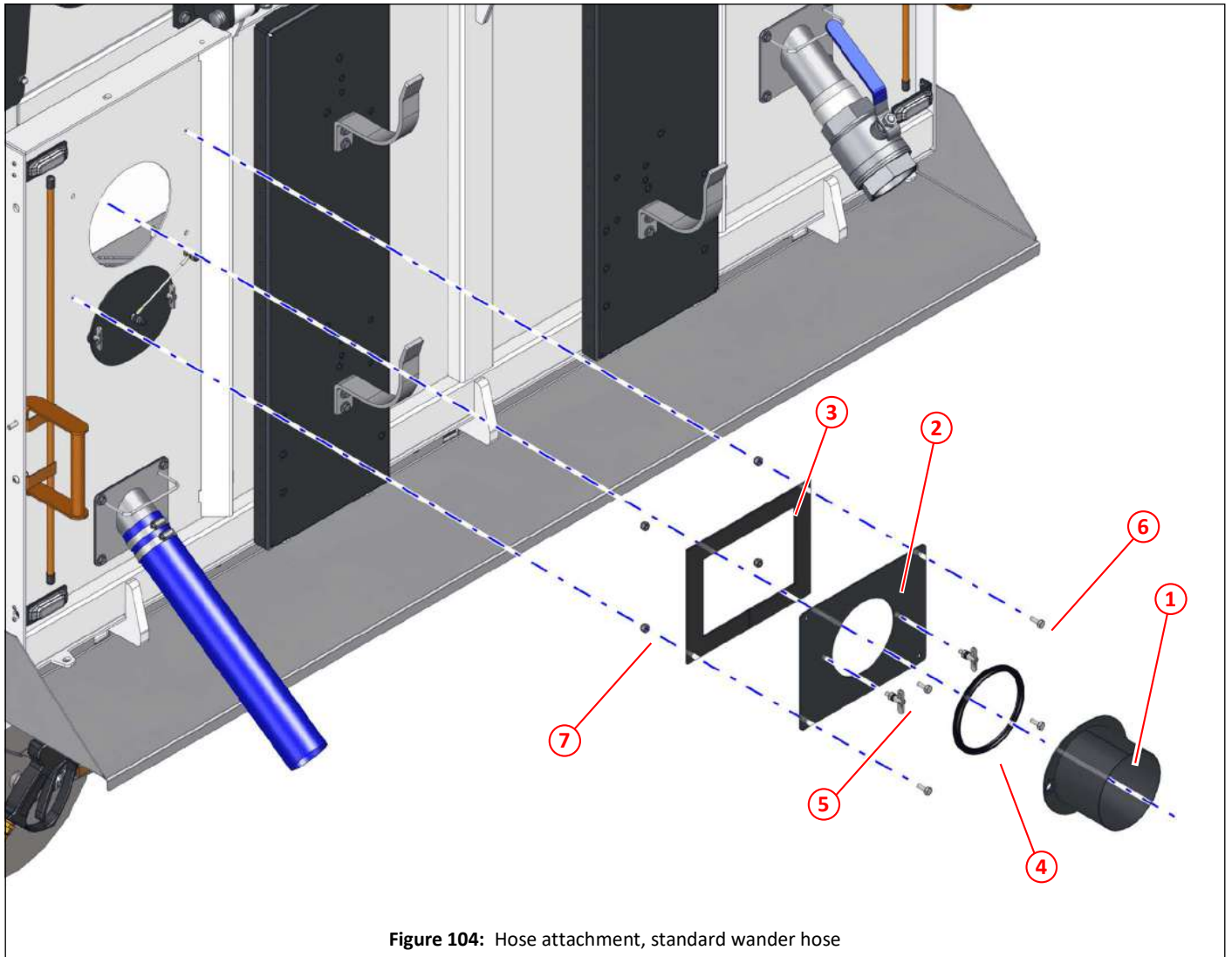

Figure 104: Hose attachment, standard wander hose

Item	Part No	Qty	Description
①	012488	1	Wander hose spigot
②	023009	1	Mounting adapter, wander hose
③	010546	1	Inseal strip, cut length as required
④	025222	1	Titanfast, section DX78, cut length as required
⑤	012253	2	Antiluce, small
⑥	000256	4	Setscrew M8 x 20, stainless steel
⑦	000263	4	Nyloc nut T M8, stainless steel

Blanking cap plate, standard wander hose

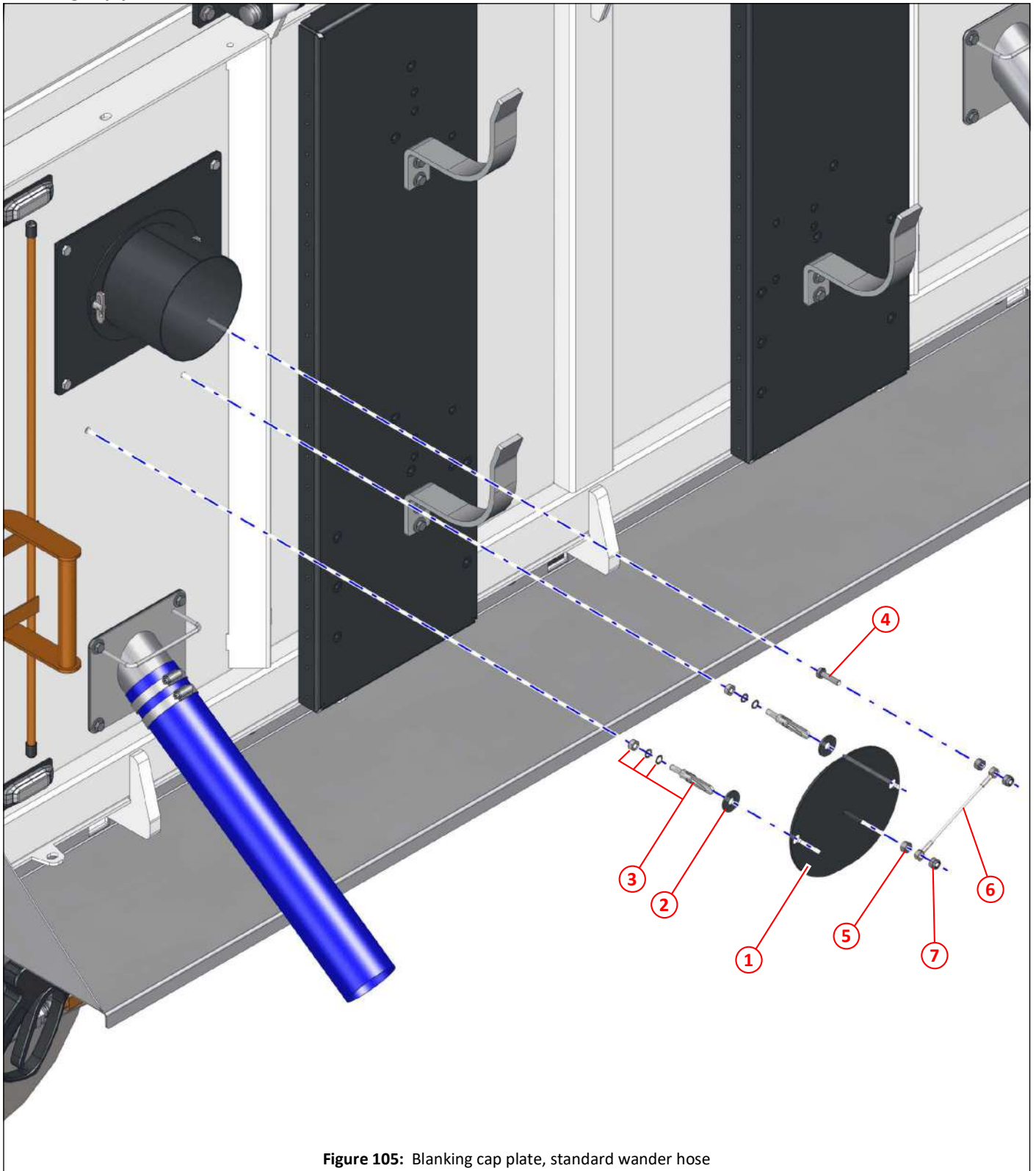

Figure 105: Blanking cap plate, standard wander hose

Item	Part No	Qty	Description
①	012486	1	Blanking cap plate
②	021979	2	Rubber sealing washer $\phi 30 \times \phi 12 \times 3$
③	012253	2	Antiluce, small
④	000258	1	Setscrew M8 x 30, stainless steel
⑤	000262	2	Full nut M8, stainless steel
⑥	020711	1	Cable leash
⑦	000263	2	Nyloc nut T M8, stainless steel

Hose hooks, standard wander hose

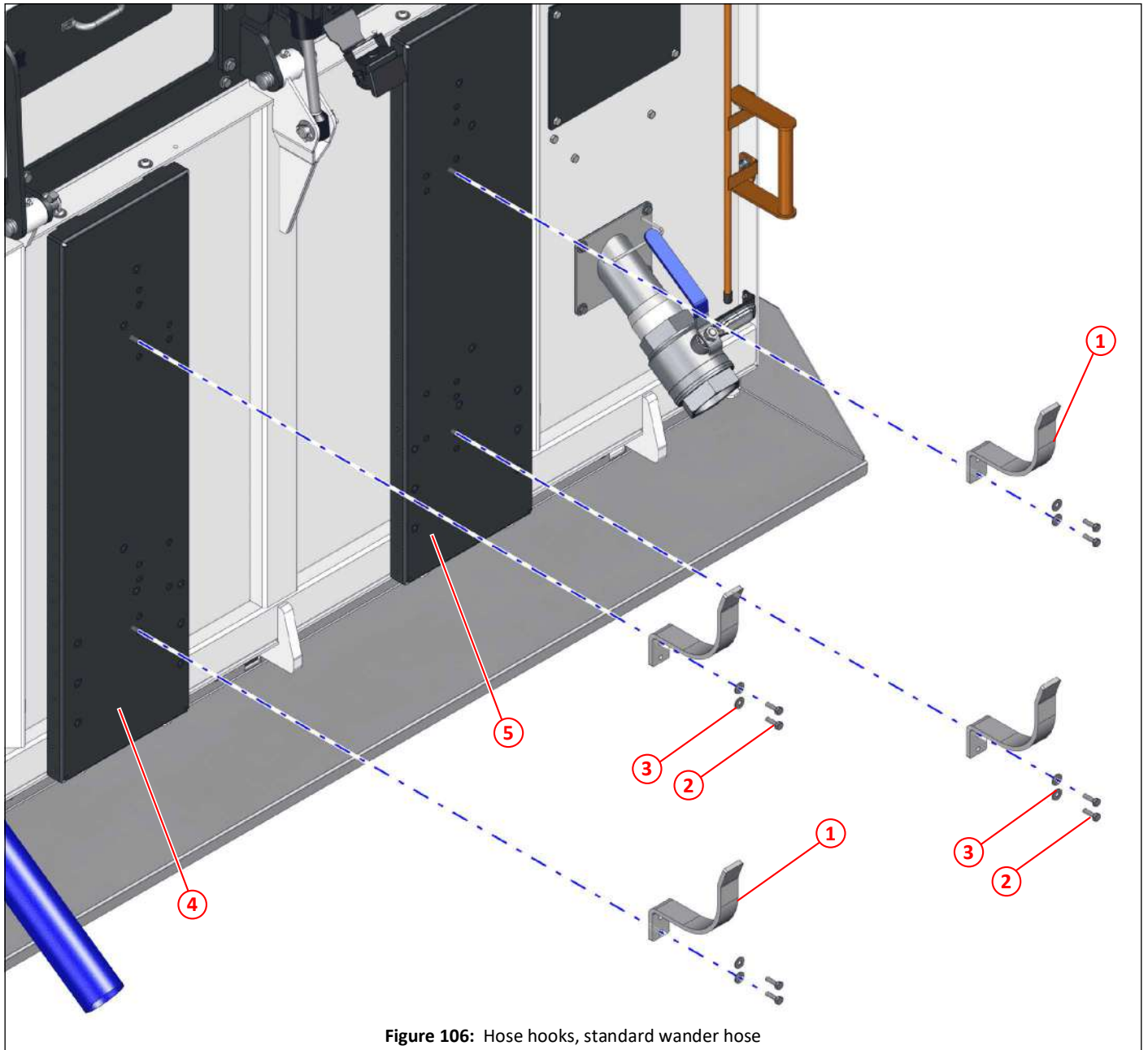

Figure 106: Hose hooks, standard wander hose

Item	Part No	Qty	Description
①	010245	4	Hose hook, wander hose
②	000257	8	Setscrew m8 x 25, stainless steel
③	000264	8	Washer M8, stainless steel
④	046982	1	Options bracket, left hand, rear door
⑤	046983	1	Options bracket, right hand, rear door

Wander boom arrangement

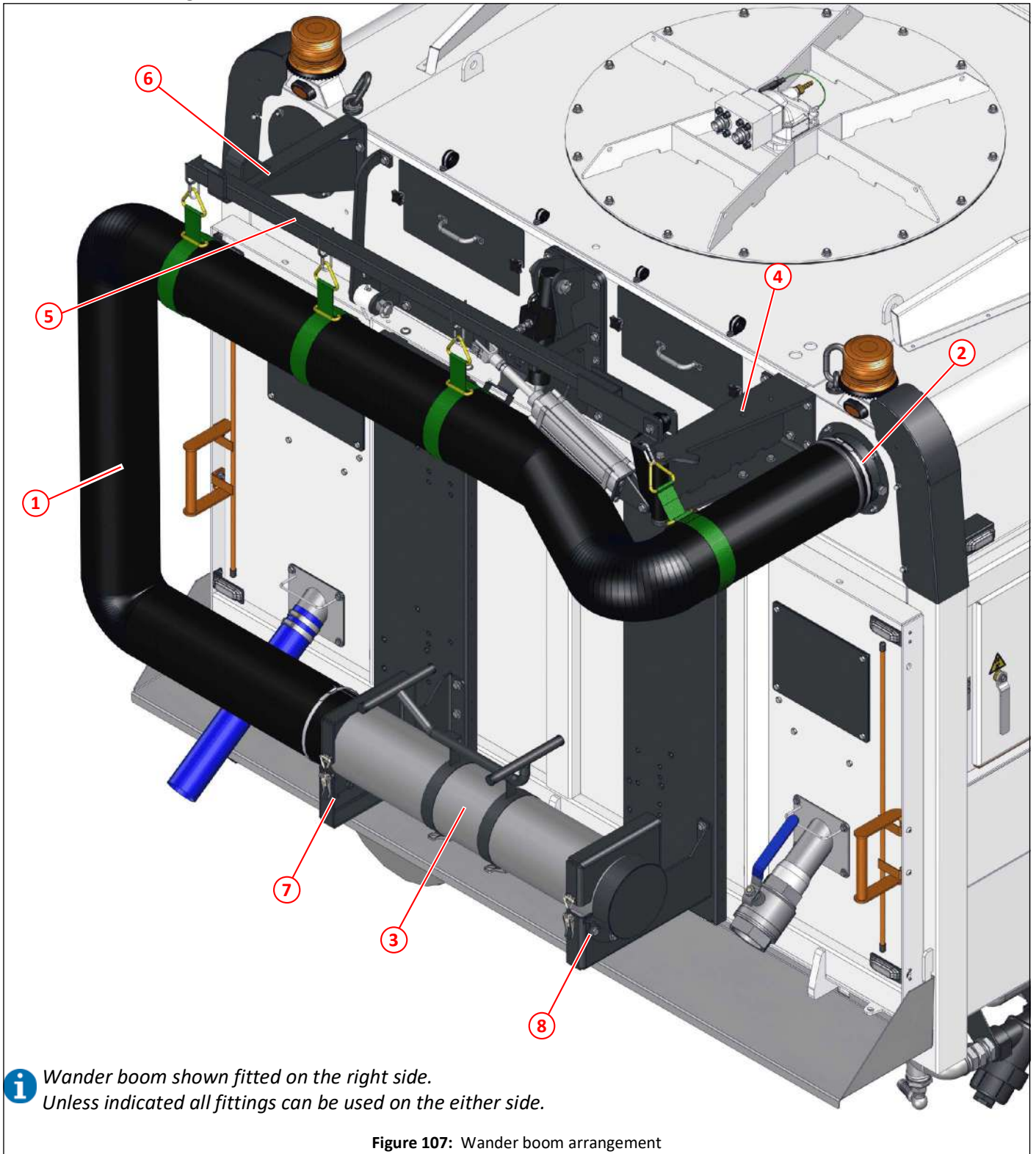

Figure 107: Wander boom arrangement

Item	Part No	Qty	Description	
①	025214	1	Wander hose, ϕ 180 4.5m	
②	025225	1	Wander hose sleeve ϕ 180	
③	035959	1	Boom tube ϕ 180	
④	047004	1	Boom hinge	
⑤	027926	1	Hose support boom	
⑥		1	Stowage bracket, 2 versions available	134
⑦	047071	1	Boom stowage cup ϕ 180, left hand	
⑧	047070	1	Boom stowage cup ϕ 180, right hand	

Wander boom, hose and boom tube

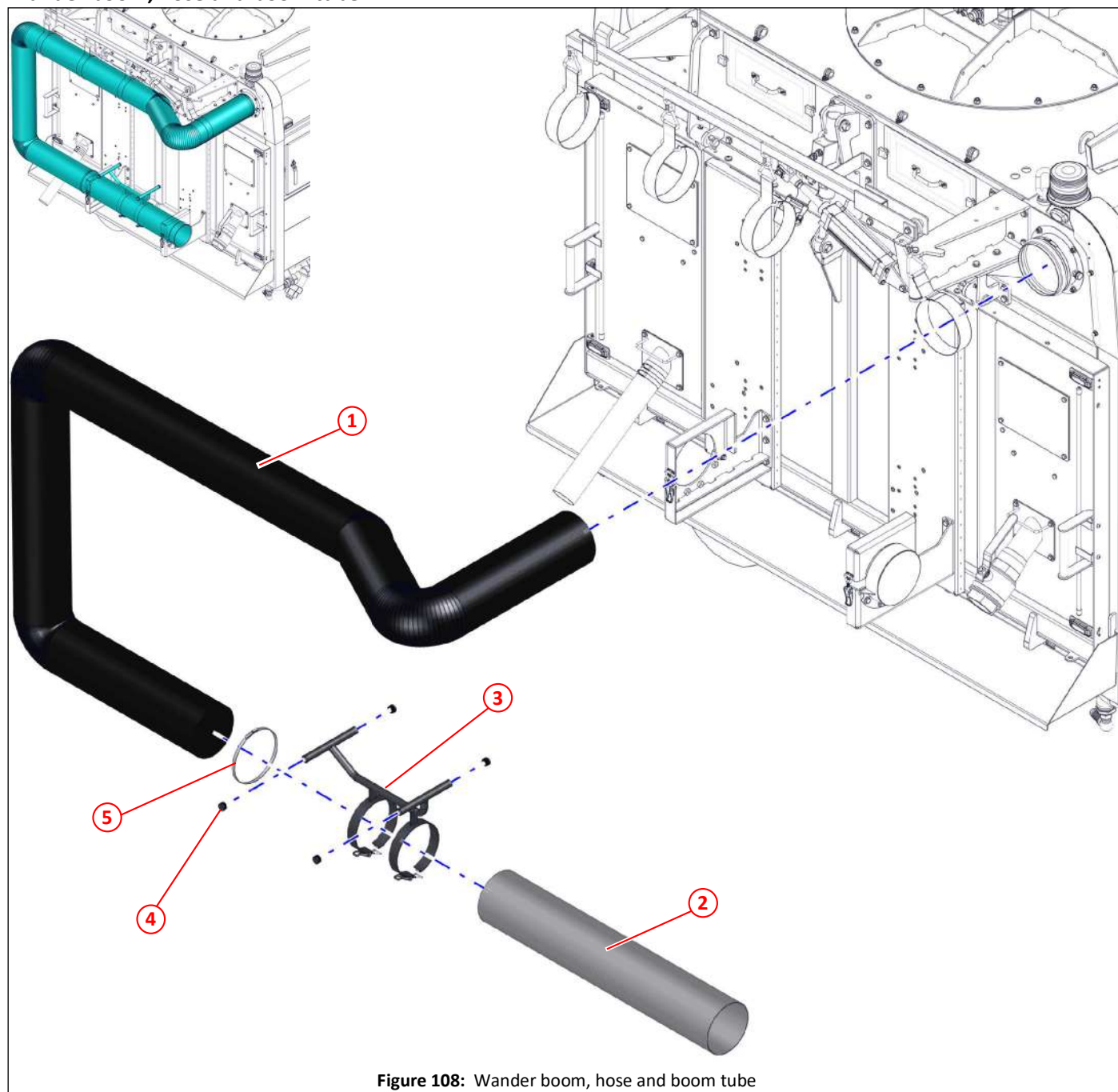

Figure 108: Wander boom, hose and boom tube

Item	Part No	Qty	Description
①	025214	1	Wander hose, ϕ 180 4.5m
②	035959	1	Boom tube ϕ 180
③	039283	1	Boom handle ϕ 180
④	026173	1	Plastic plug ϕ 25.4 (black)
⑤	012933	1	Jubilee clip, No 10.50 (ϕ 235 - ϕ 267)

Wander boom, hose sleeve

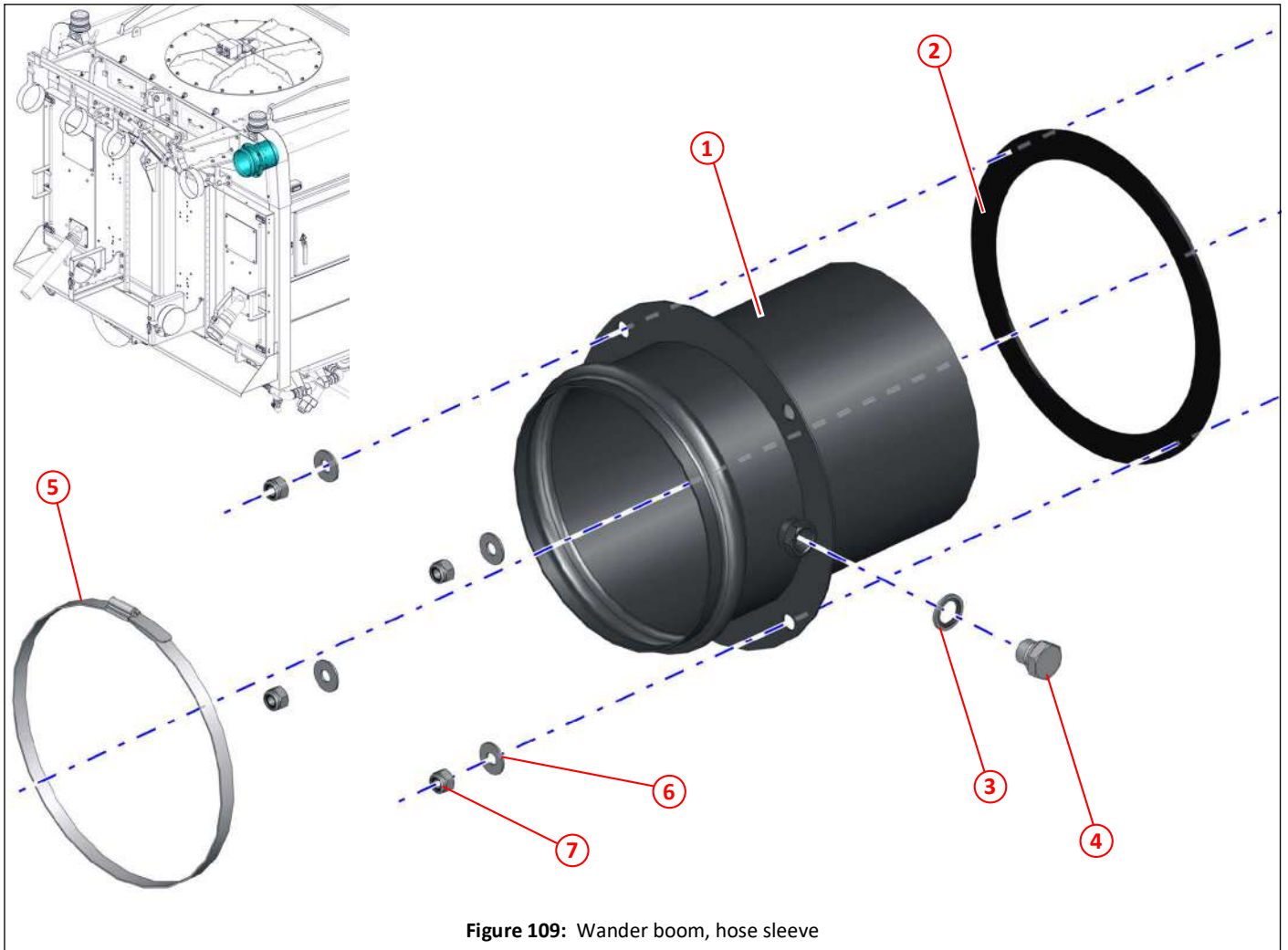

Figure 109: Wander boom, hose sleeve

Item	Part No	Qty	Description
①	025225	1	Wander hose sleeve $\phi 180$
②	013645	1	Inseal strip 3 x 19, cut to required length
③	011153	1	Dowty seal $\frac{3}{8}$ " BSP
④	011242	1	Plug $\frac{3}{8}$ " BSP
⑤	012933	1	Jubilee clip, No 10.50 ($\phi 235 - \phi 267$)
⑥	000264	4	Washer M8, stainless steel
⑦	000263	4	Nyloc nut T M8, stainless steel

Wander boom, hinge mounting bracket

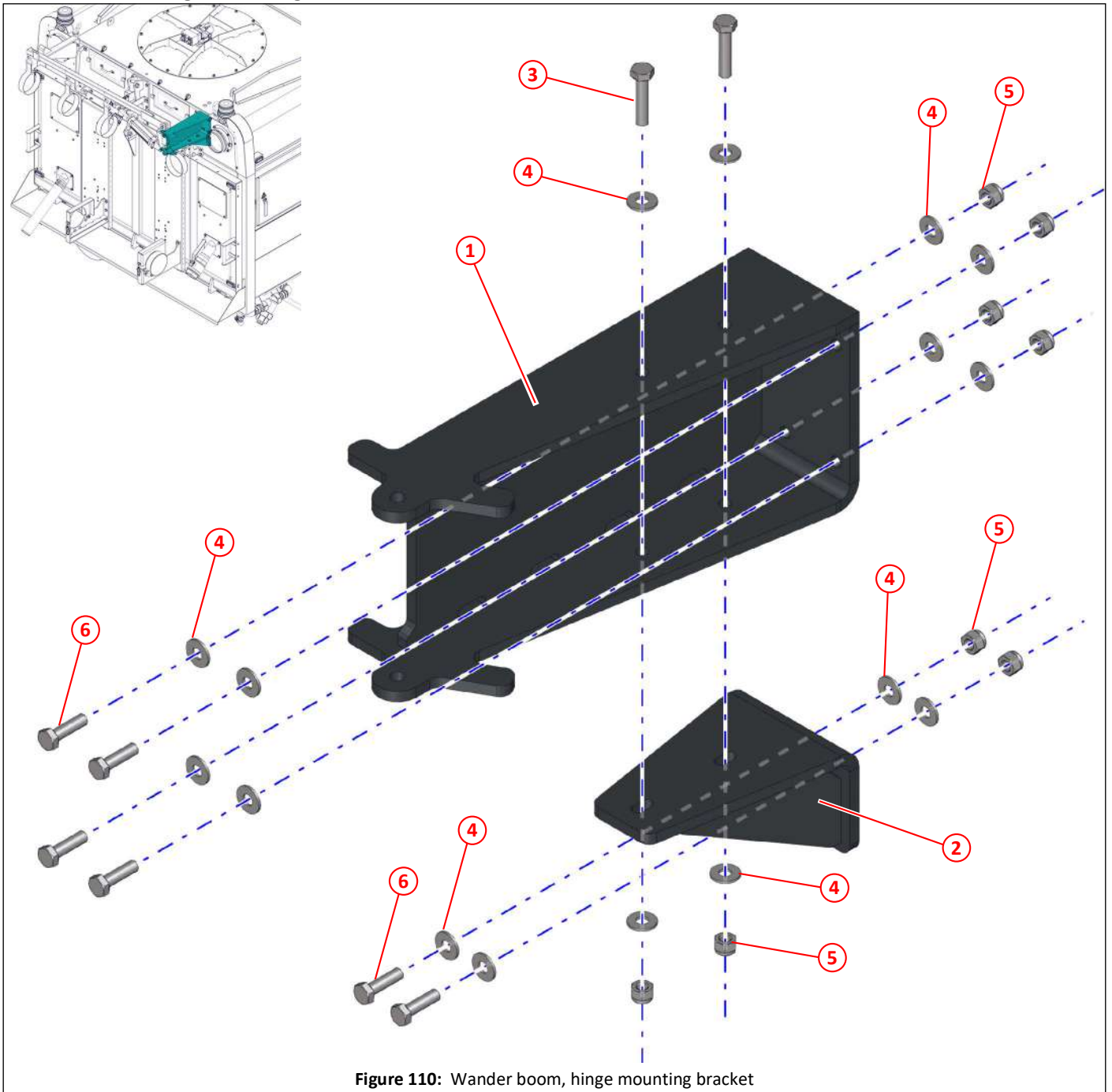

Figure 110: Wander boom, hinge mounting bracket

Item	Part No	Qty	Description
①	047004	1	Boom hinge
②	047036	1	Boom hinge support
③	000072	2	Setscrew M10 x45
④	011094	16	Washer M10
⑤	011075	8	Nyloc nut T M10
⑥	011033	6	Setscrew M10 x 35

Wander boom, swivel hinge

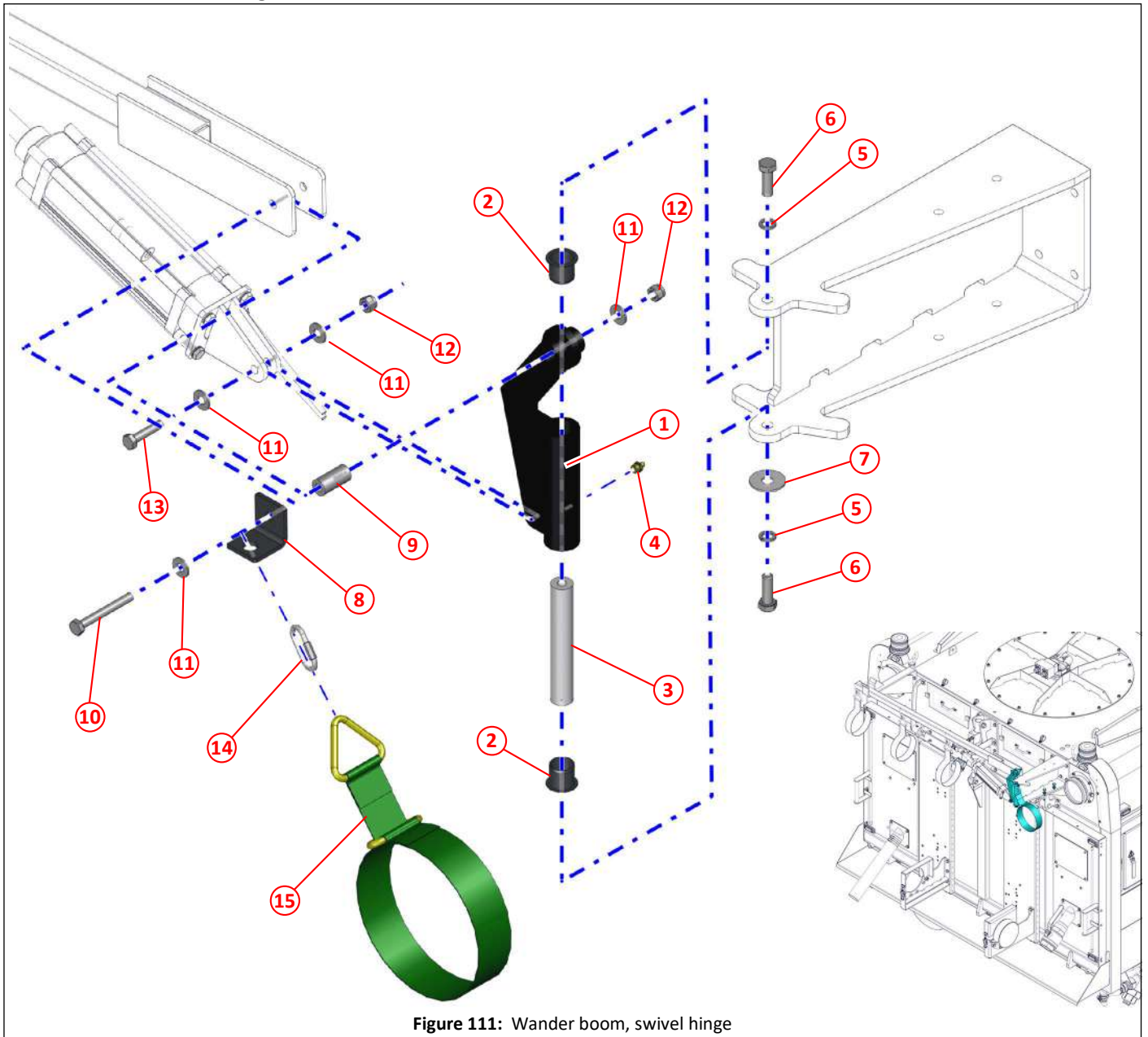

Figure 111: Wander boom, swivel hinge

Item	Part No	Qty	Description
①	025219	1	Wander boom hose hinge
②	013662	2	Bush
③	023490	1	Hinge shaft, boom
④	010903	1	Grease nipple $\frac{1}{8}$ " BSP, straight
⑤	011097	2	Spring washer M12
⑥	011053	2	Setscrew M12 x 35
⑦	013448	1	Washer $\phi 40$ x $\phi 13$ x 2
⑧	012548	1	Angle bracket
⑨	014399	1	Spacer $\phi 20$ x $\phi 10.5$ x 41
⑩	011038	1	Bolt M10 x 80
⑪	011094	4	Washer M10
⑫	011075	2	Nyloc nut M10
⑬	000072	1	Setscrew M10 x45
⑭	010606	4	Carabiner
⑮	025235	4	Wander hose strap

Wander boom, lift support

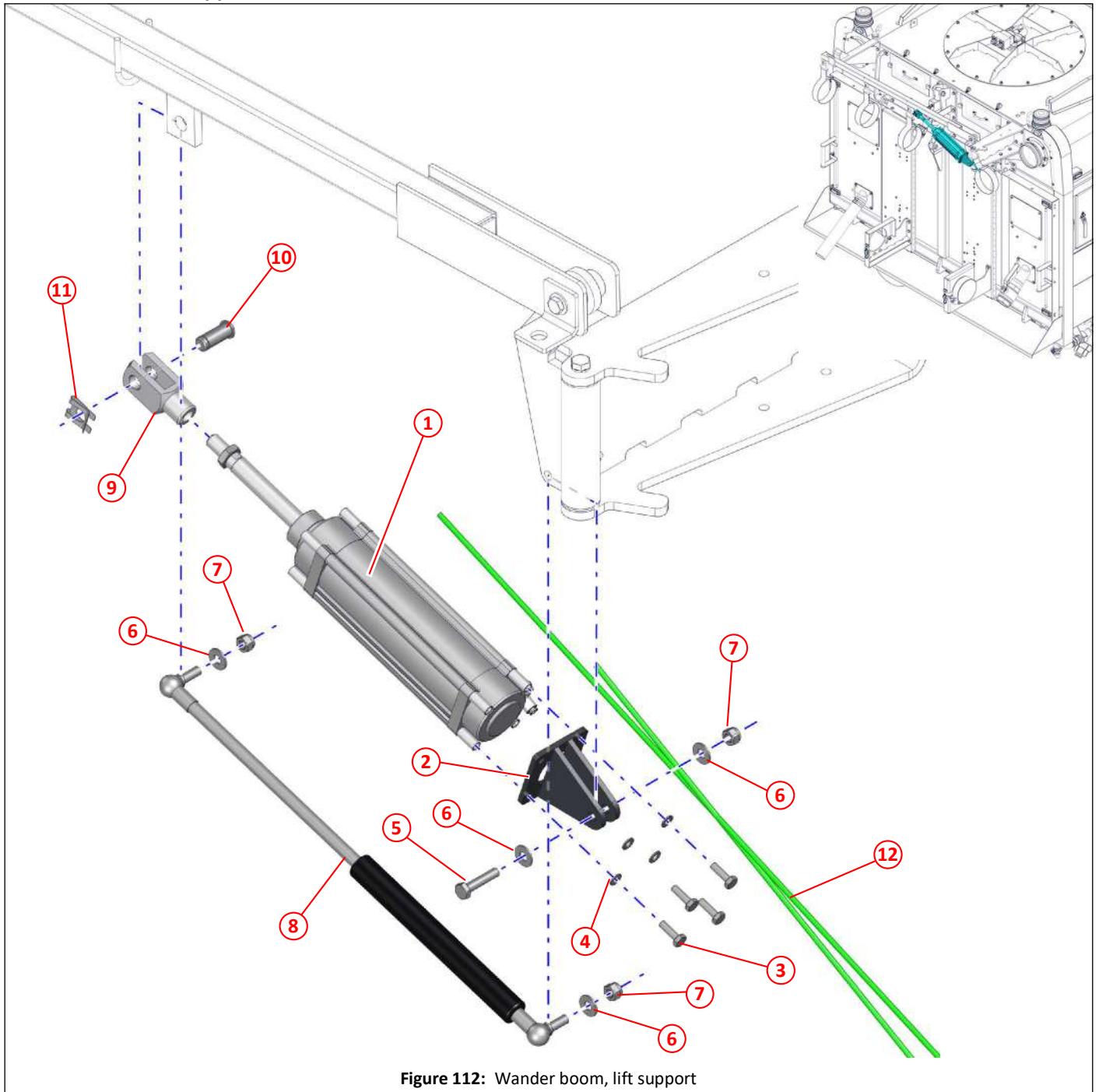

Figure 112: Wander boom, lift support

Item	Part No	Qty	Description
①	028306	1	Pneumatic cylinder $\phi 63 \times 160$
②	028305	1	Air ram pivot bracket
③	011011	4	Setscrew M8 x 25
④	011093	4	Spring washer M8
⑤	000072	1	Setscrew M10 x45
⑥	011094	4	Washer M10
⑦	011075	3	Nyloc nut T M10
⑧	021993	1	Gas strut
⑨	020299	1	Clevis pneumatic M16 x 1.5
⑩	022673	1	Clevis pin (turned)
⑪	022674	1	Retaining clip M16
⑫	024650	2	$\phi 6$ mm green air pipe, cut to length as required

Wander boom, hose support

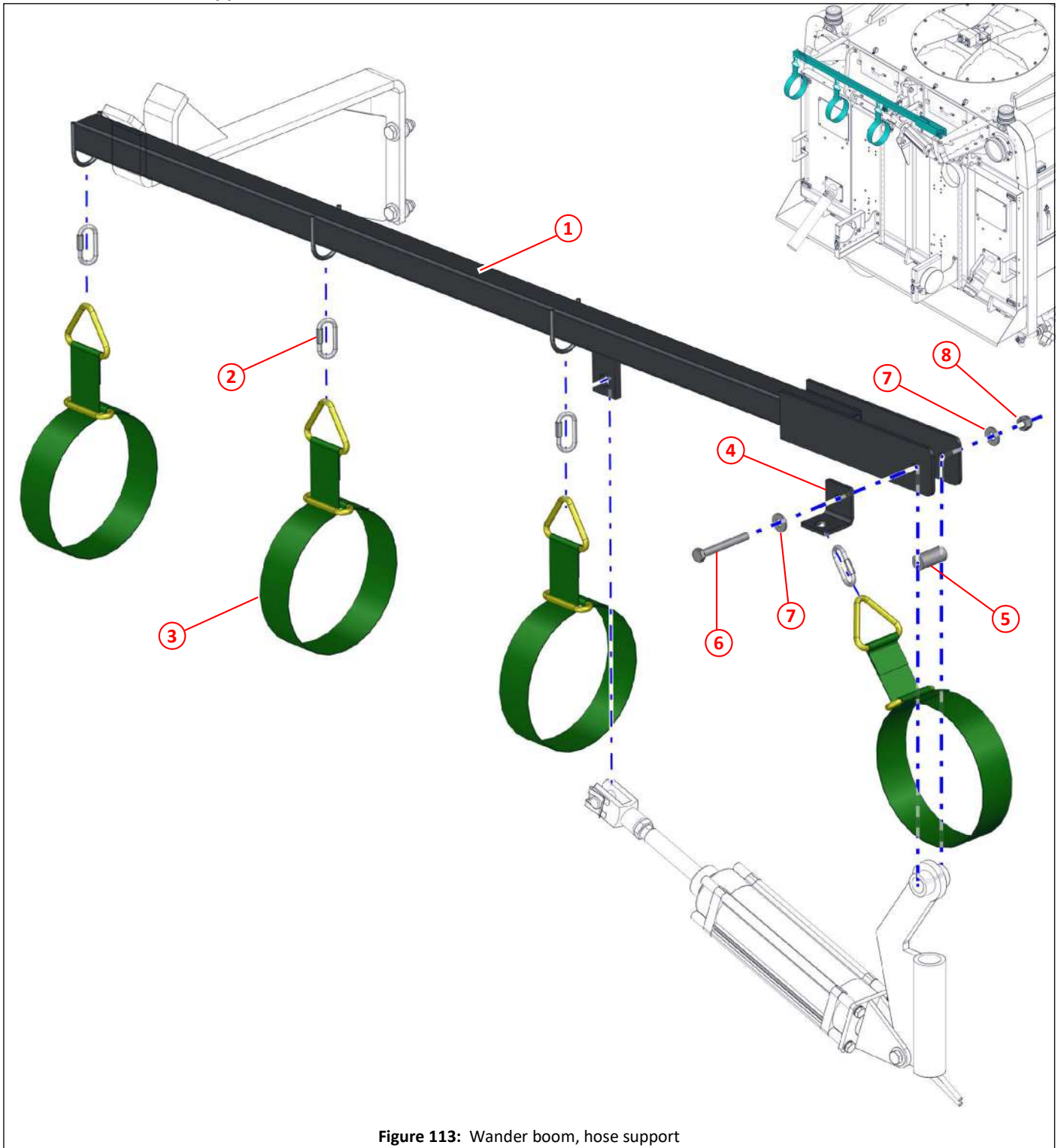

Figure 113: Wander boom, hose support

Item	Part No	Qty	Description
①	027926	1	Hose support boom
②	010606	4	Carabiner
③	025235	4	Wander hose strap
④	012548	1	Angle bracket
⑤	014399	1	Spacer $\phi 20 \times \phi 10.5 \times 41$
⑥	011038	1	Bolt M10 x 80
⑦	011094	2	Washer M10
⑧	011075	1	Nyloc nut M10

Wander boom, stowage bracket

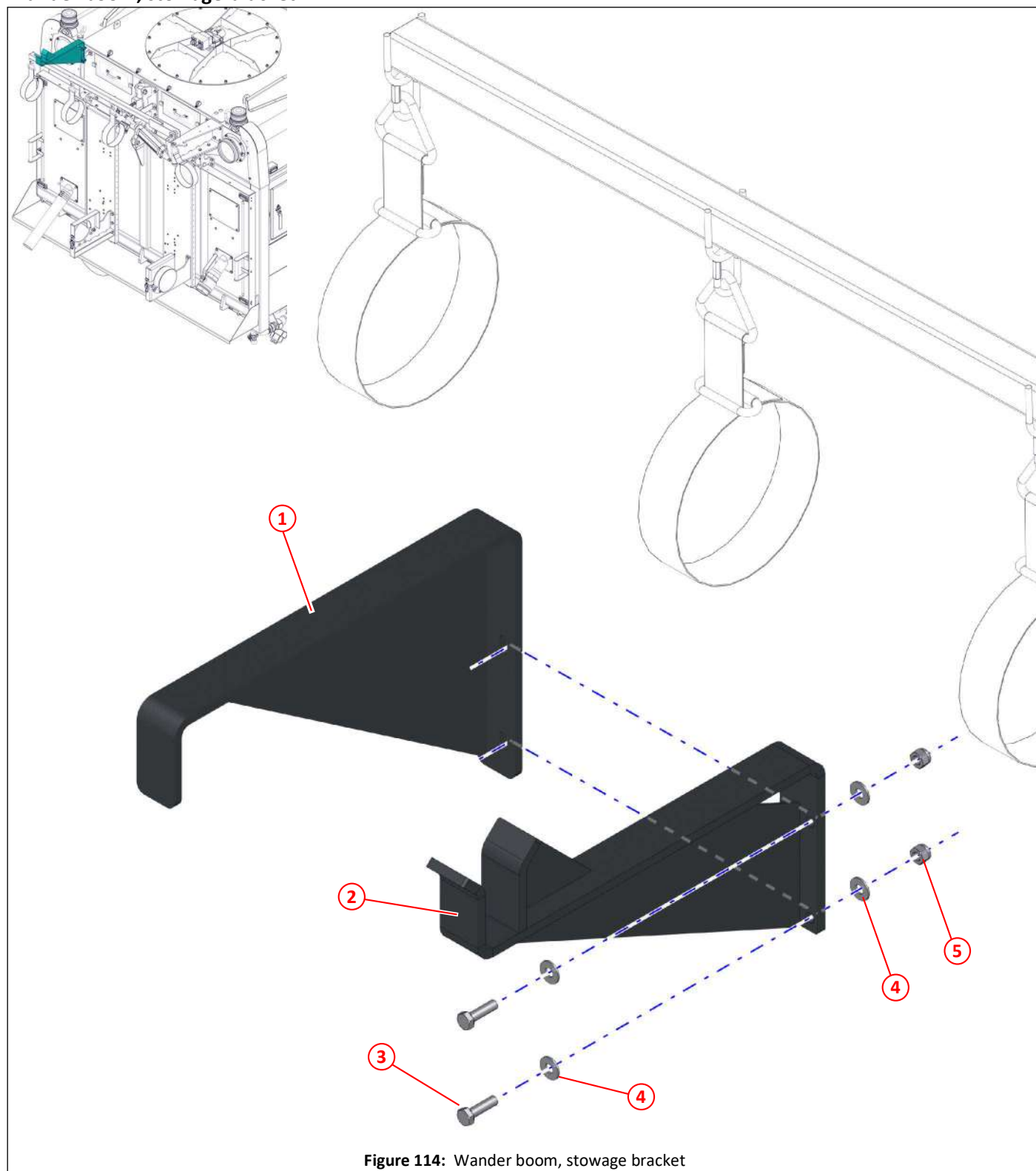

Figure 114: Wander boom, stowage bracket

Item	Part No	Qty	Description	
①	034313	1	Boom stowage bracket, gas strut version	
②	048225	1	Boom stowage bracket, pneumatic lift version	
③	011033	2	Setscrew M10 x 35	
④	011094	4	Washer M10	
⑤	011075	2	Nyloc nut T M10	

Wander boom, tube blanking stowage

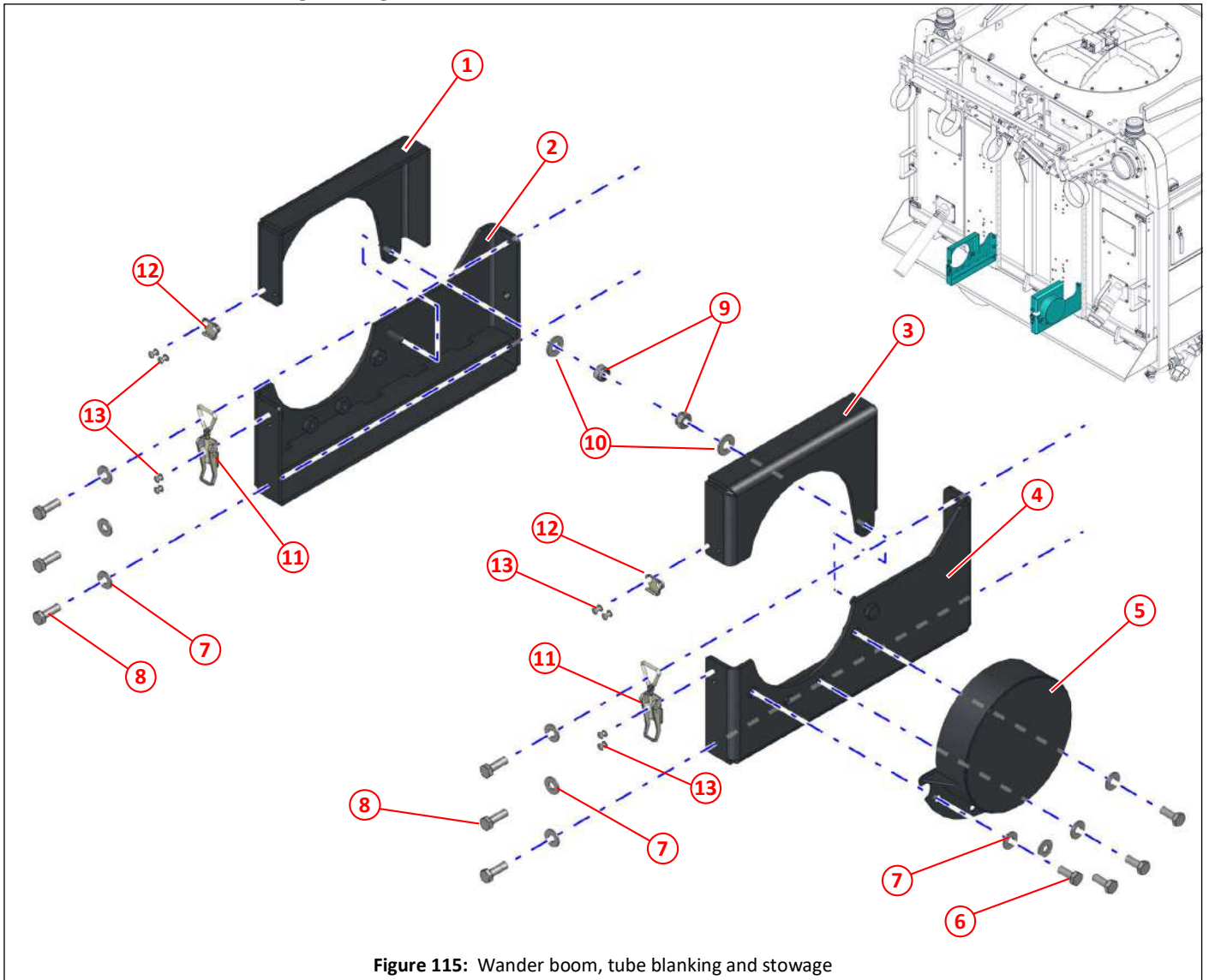
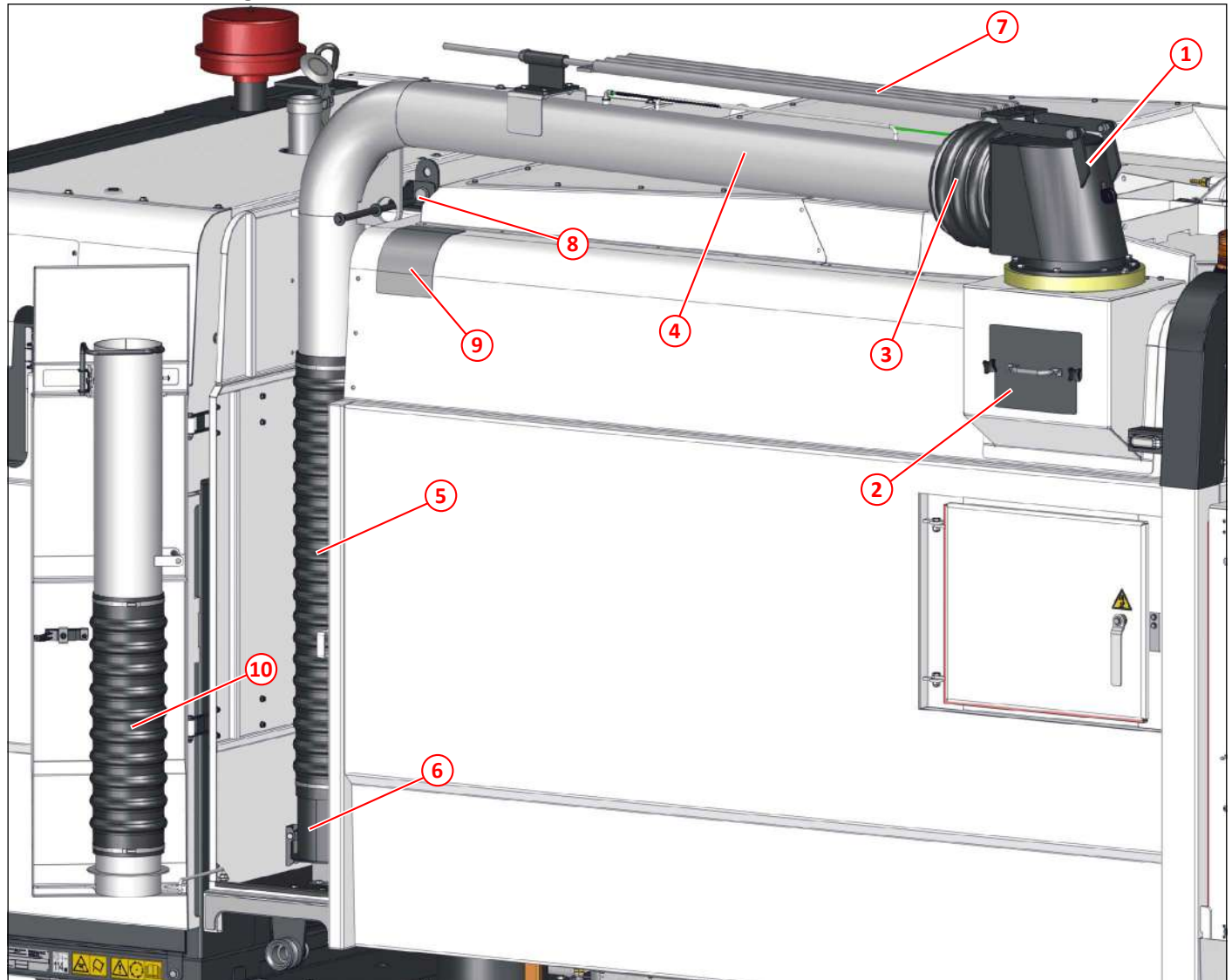

Figure 115: Wander boom, tube blanking and stowage

Item	Part No	Qty	Description
①	035962	1	Boom mounting lock, left hand side
②	047071	1	Boom stowage cup ø180, left hand side
③	039282	1	Boom mounting lock, right hand side
④	047070	1	Boom stowage cup ø180, right hand
⑤	047069	1	Boom stowage blanking cup ø180
⑥	011031	4	Setscrew M10 x 25
⑦	011094	10	Washer M10
⑧	011032	6	Setscrew M10 x30
⑨	011077	2	Nyloc nut T M12
⑩	011096	2	Washer M12
⑪	010509	2	Ojop fastener with hinged toggle
⑫	021841	2	Toggle clip hook
⑬	011131	8	Seal blind rivet ø4.8 x 18

Overhead boom arrangement



i Overhead boom shown fitted on the left side. Unless indicated all fittings can be used on the either side.

Figure 116: Overhead boom arrangement

Item	Part No	Qty	Description
①	013793	1	Boom elbow
②	032351	1	Access cover, overhead boom carrier
③	044107	1	Cuff, boom pivot
④	047077	1	Suction pipe with elbow, overhead boom
⑤	047088	1	Hose 1.025m, overhead boom
⑥	050988	1	Hose coupling, overhead boom, complete
⑦	013805	4	Tension springs
⑧	044303	1	Boom retainer
⑨	044384	1	Plate, hopper protection, overhead boom
⑩	044139	1	Overhead boom extension

Overhead boom, elbow and access cover

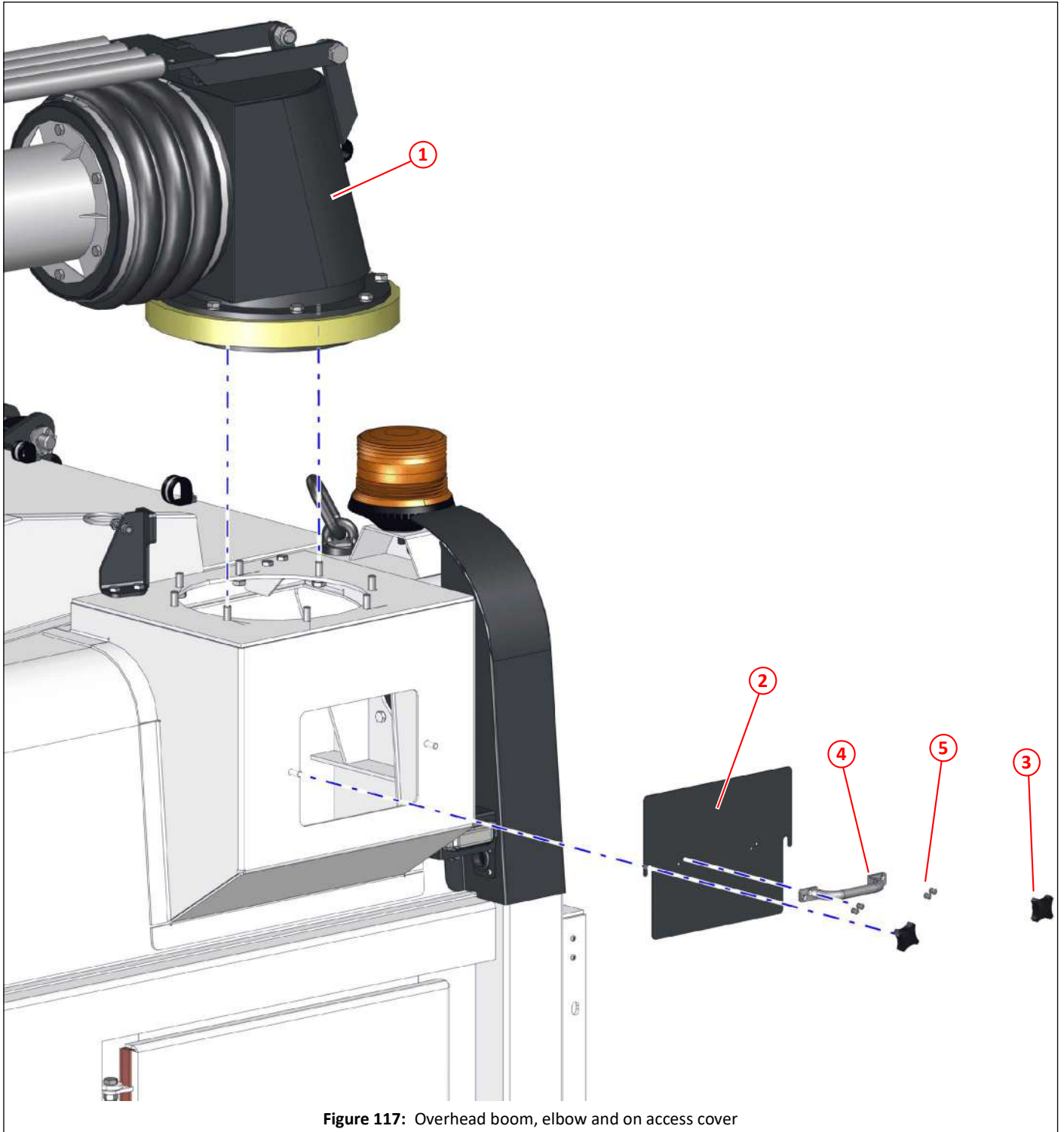

Figure 117: Overhead boom, elbow and on access cover

Item	Part No	Qty	Description
①	013793	1	Boom elbow
②	032351	1	Access cover, overhead boom carrier
③	000248	2	Grip nut M8, with brass insert
④	010502	1	Pull handle
⑤	011124	4	Blind rivet $\phi 4.0 \times 10$

Overhead boom, elbow and bearing

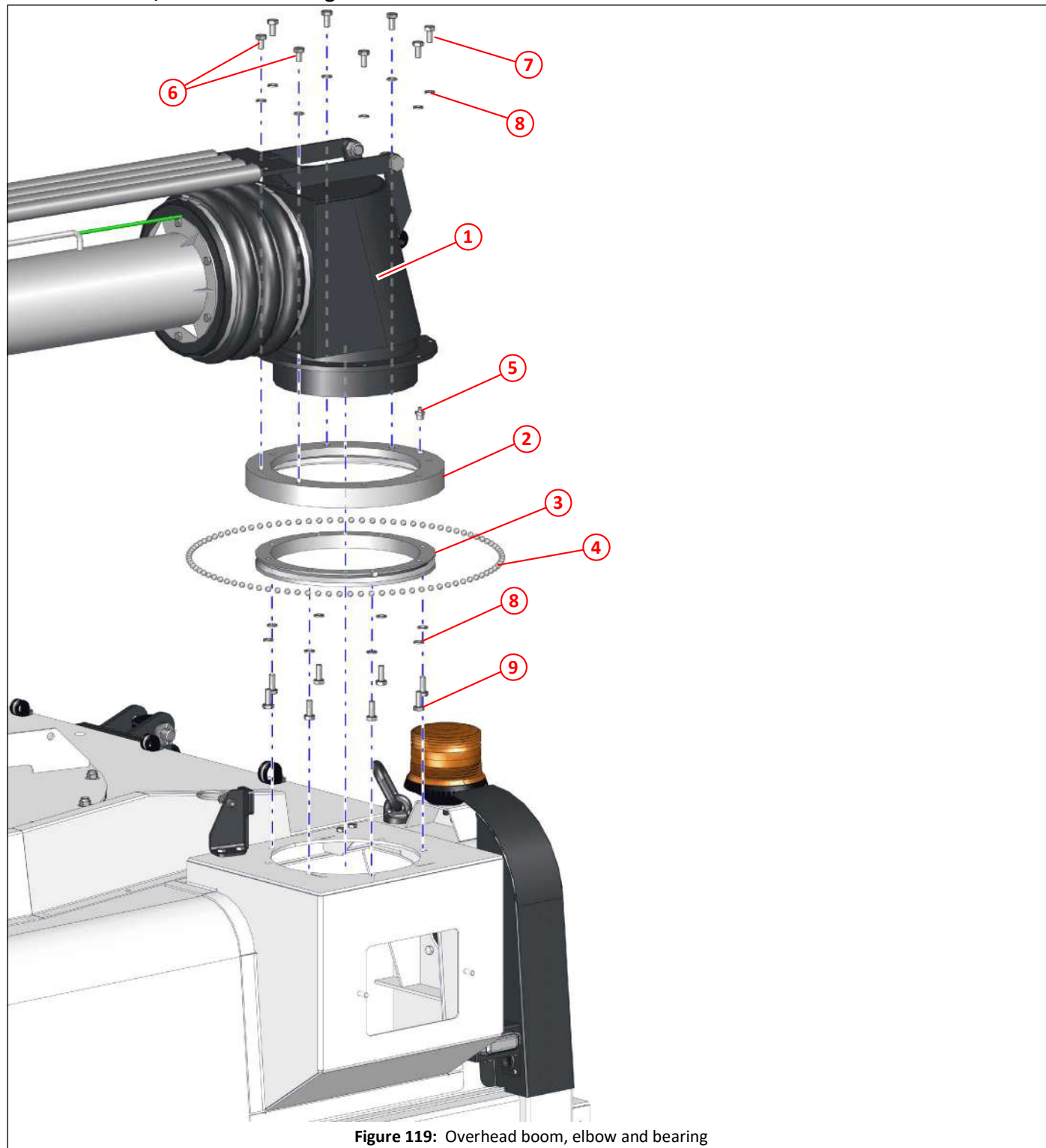

Figure 119: Overhead boom, elbow and bearing

Item	Part No	Qty	Description
①	013793	1	Boom elbow
②	013788	1	Slew ring, outer
③	013789	1	Slew ring, inner
④	013791	72	Ball 10mm, steel, overhead boom
⑤	013792	1	Grease nipple $\frac{1}{4}$ " BSP, straight
⑥	000210	2	Bolt M10 x 16
⑦	011030	6	Setscrew M10 x 20
⑧	011095	16	Spring washer M10
⑨	011031	8	Setscrew M10 x 25

Overhead boom, stop

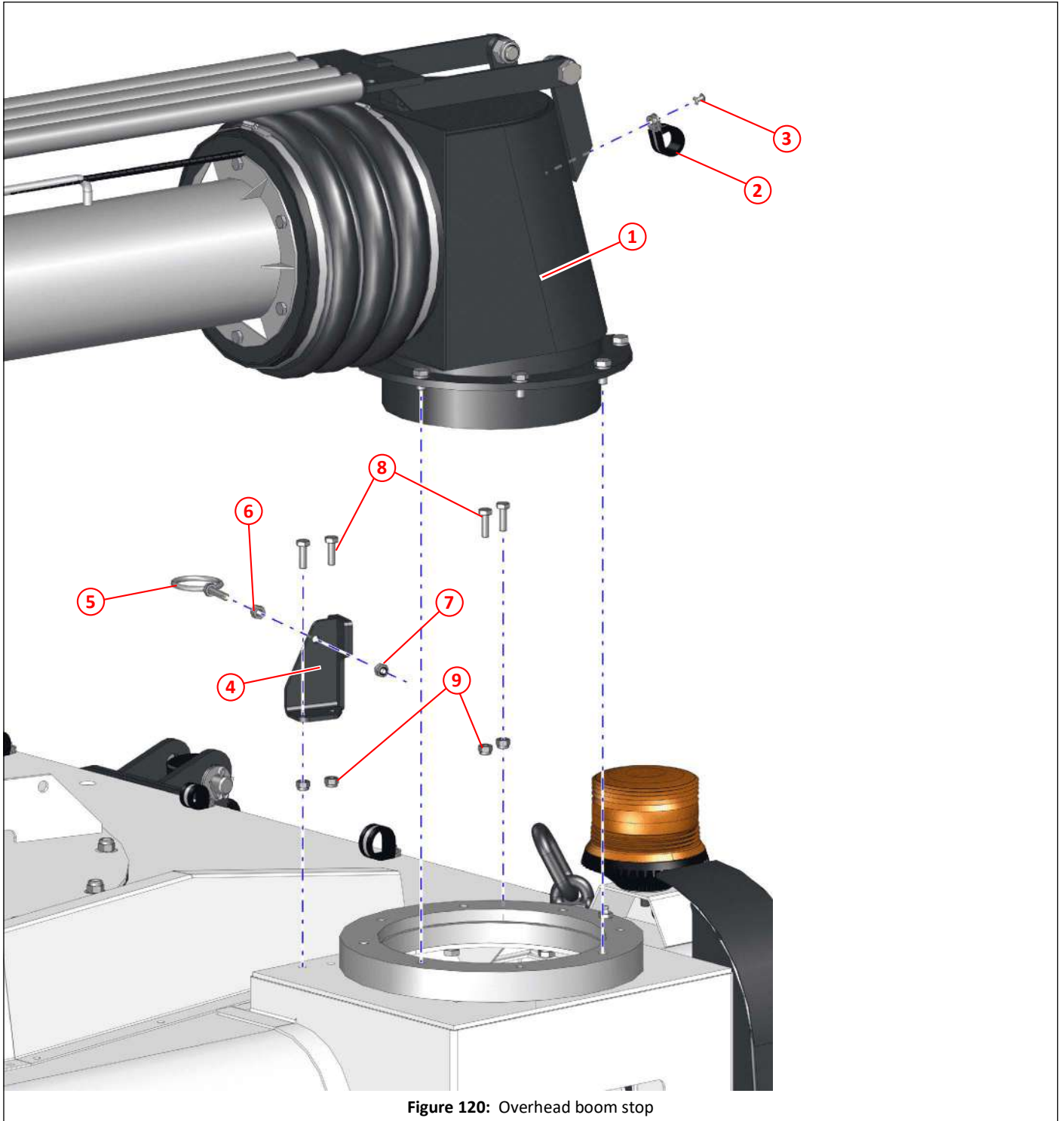

Figure 120: Overhead boom stop

Item	Part No	Qty	Description
①	013793	1	Boom elbow
②	003001	1	Clip \varnothing 22, rubber insert
③	011131	1	Seal blind rivet \varnothing 4.8 x 18
④	044143	1	Bracket, boom stop
⑤	033022	1	Hose ring
⑥	000262	1	Full nut M8, stainless steel
⑦	011073	1	Nyloc nut T M8
⑧	000257	4	Setscrew M8 x 25, stainless steel
⑨	000263	4	Nyloc nut T M8, stainless steel

Overhead boom, spring anchor

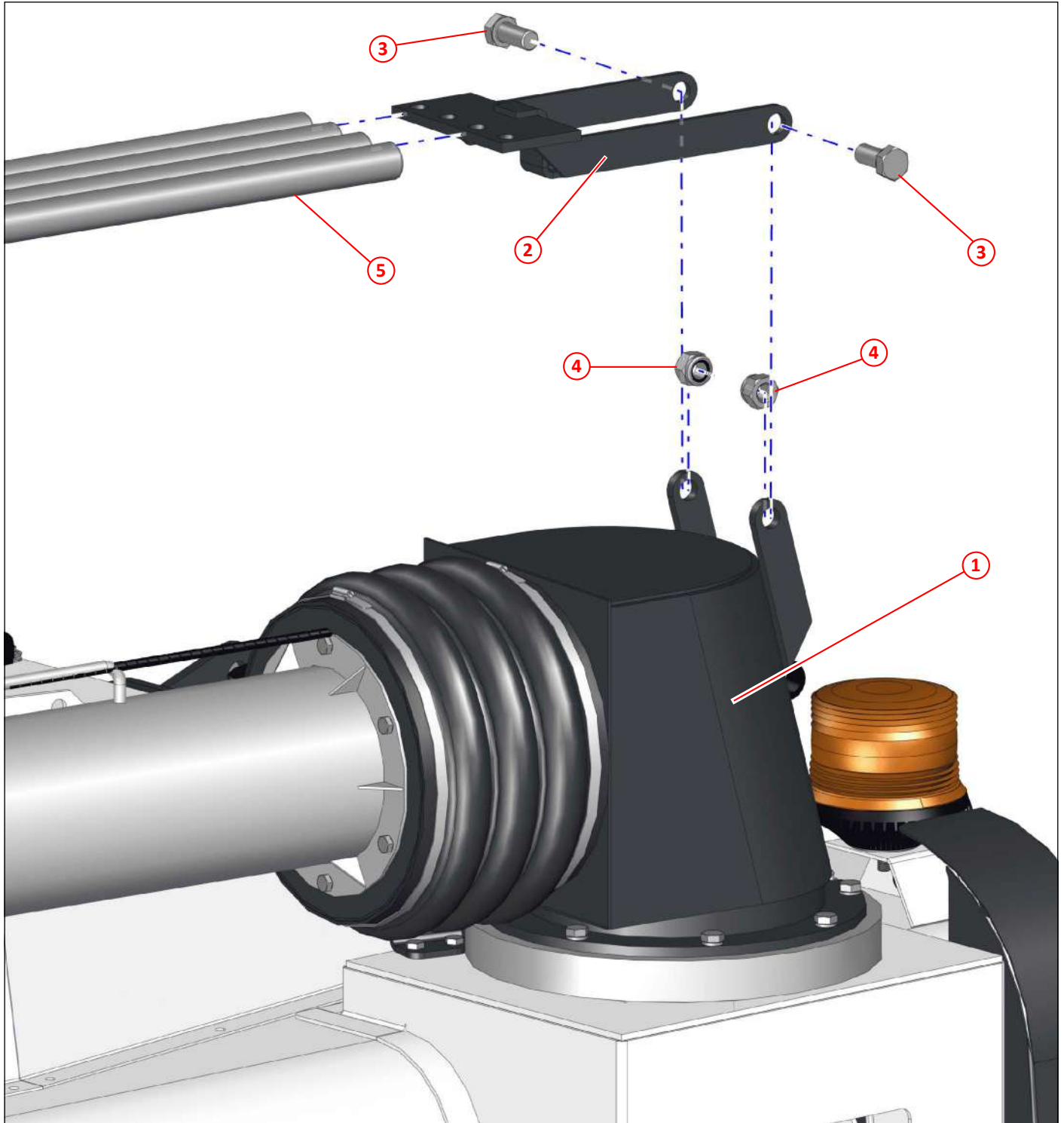

Figure 121: Overhead boom, spring anchor

Item	Part No	Qty	Description
①	013793	1	Boom elbow
②	013801	1	Spring anchor
③	011141	2	Bolt M16 x 35
④	011060	2	Nyloc nut T M16
⑤	013805	4	Spring 800mm long

Overhead boom, cuff

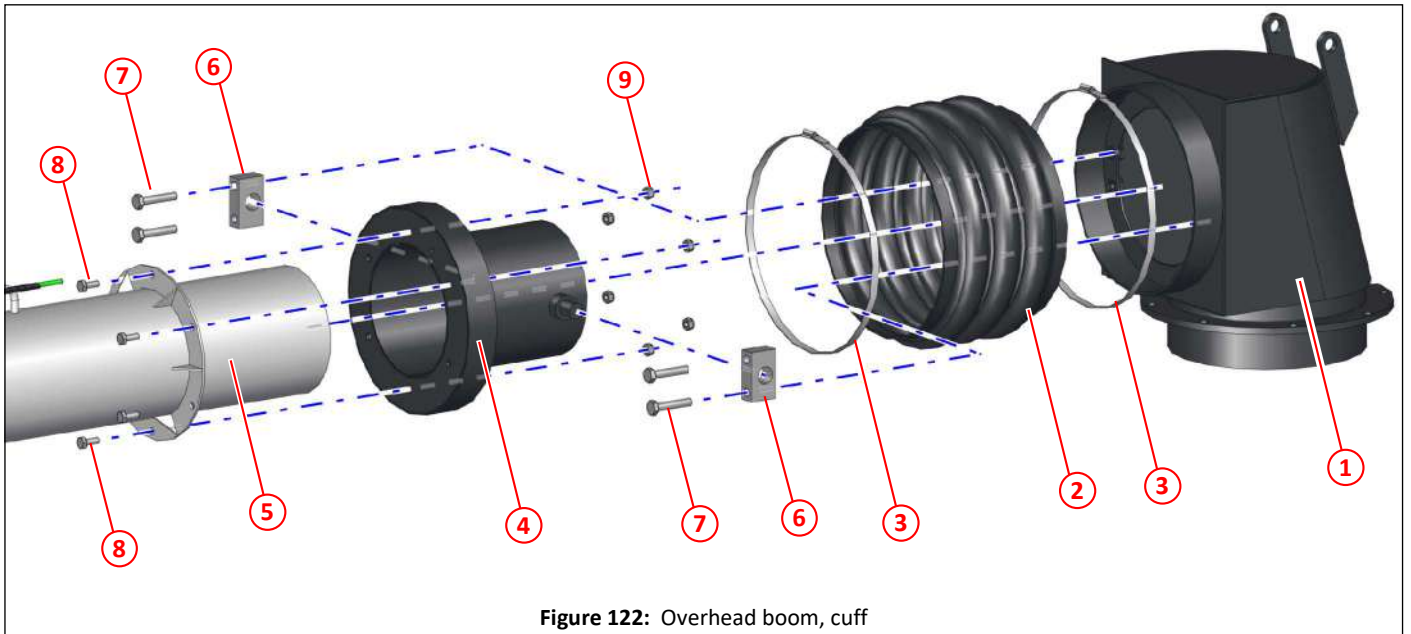

Figure 122: Overhead boom, cuff

Item	Part No	Qty	Description
①	013793	1	Boom elbow
②	044107	1	Cuff, boom pivot
③	012933	2	Jubilee clip, No 10.50 (ø235 - ø267)
④	044121	1	Boom pivot, overhead boom
⑤	047077	1	Suction pipe with elbow, overhead boom
⑥	013798	2	Pivot block
⑦	011035	4	Setscrew M01 x 50
⑧	011010	6	Setscrew M8 x 20
⑨	011073	6	Nyloc nut T M8

Overhead boom, spring adjuster

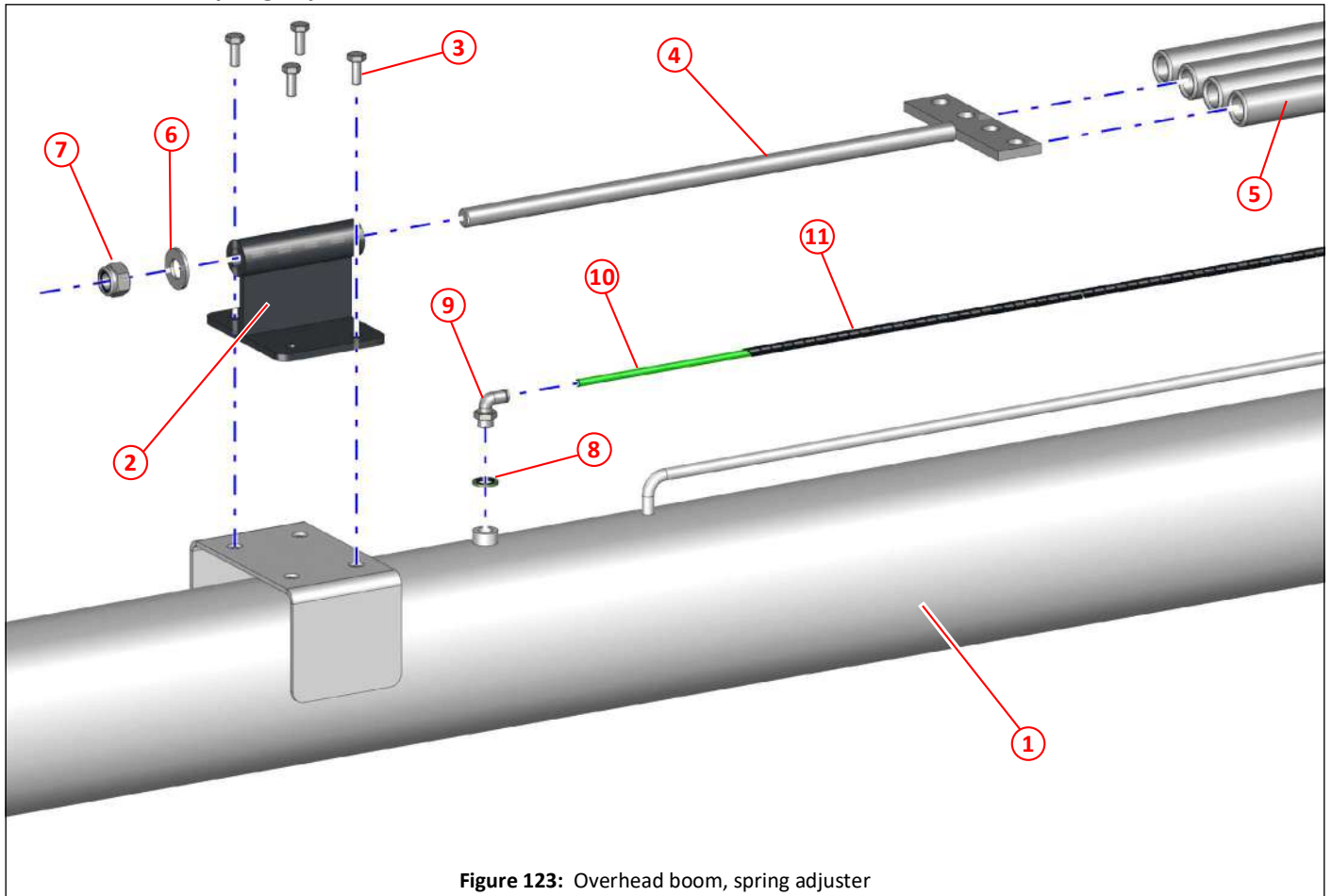

Figure 123: Overhead boom, spring adjuster

Item	Part No	Qty	Description
①	047077	1	Suction pipe with elbow, overhead boom
②	044126	1	Bracket, spring tensioner
③	011010	4	Setscrew M8 x 20
④	013804	1	Tensioner, overhead boom
⑤	013805	4	Spring 800mm long
⑥	011135	1	Washer M16
⑦	011060	1	Nyloc nut T M16
⑧	011152	1	Dowty seal $\frac{1}{4}$ " BSP
⑨	023203	1	Push in swivel elbow, $\phi 6 \times \frac{1}{4}$ " BSP
⑩	024650	1	$\phi 6$ mm green air pipe, cut to length as required
⑪	004161	1	Flex cable conduit, split, $\phi 15.7$, cut to length as required

Overhead boom, retainer

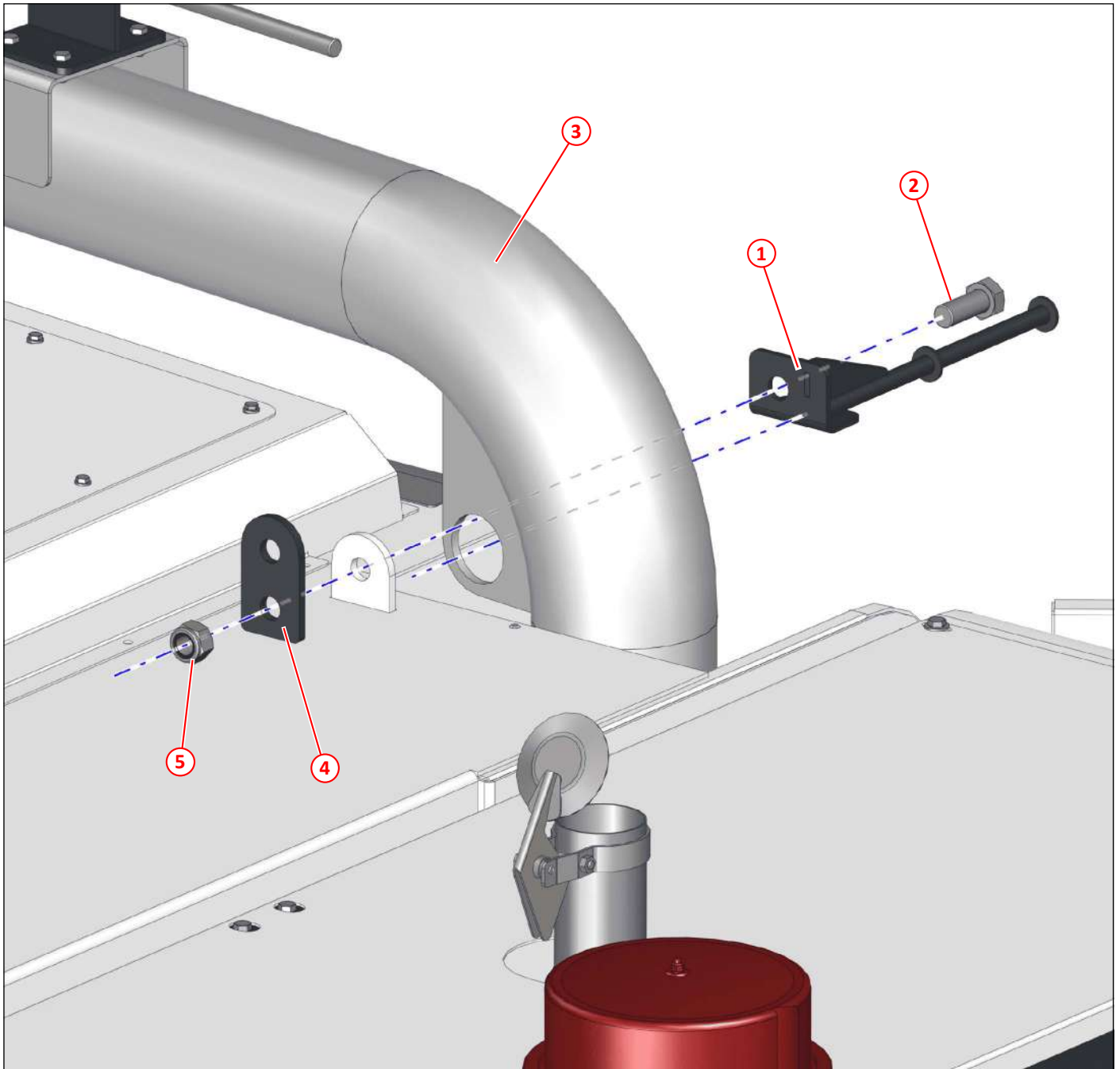

Figure 124: Overhead boom, retainer

Item	Part No	Qty	Description
①	044303	1	Boom retainer
②	011061	1	Bolt M20 x 50
③	047077	1	Suction pipe with elbow, overhead boom
④	045670	1	Lifting eye plate, overhead boom
⑤	011082	1	Nyloc nut M20

Overhead boom, retrieval hook

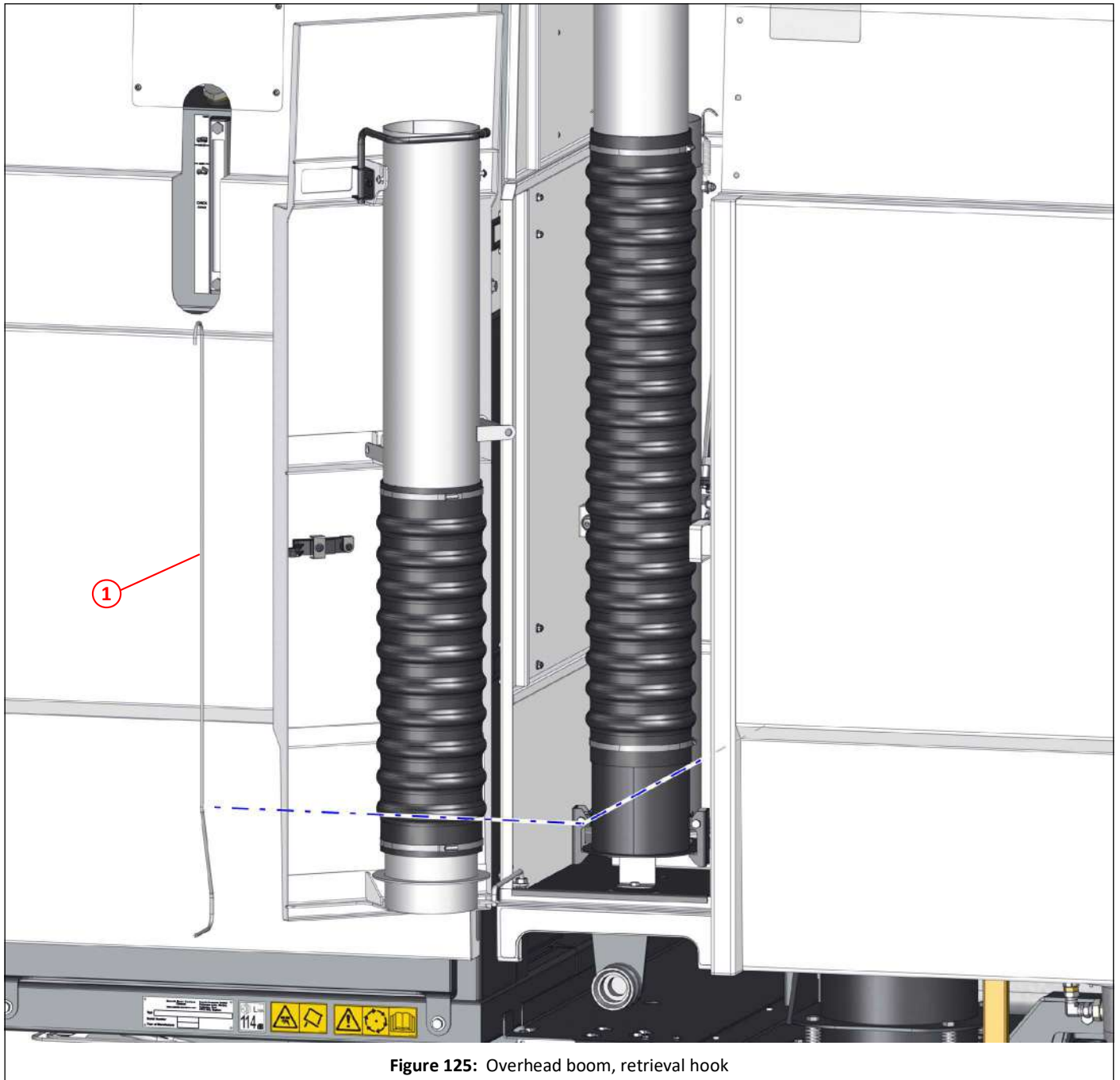

Figure 125: Overhead boom, retrieval hook

Item	Part No	Qty	Description
①	044753	1	Hook, boom retrieval. Stored in back of locker.

Overhead boom, hose and coupling

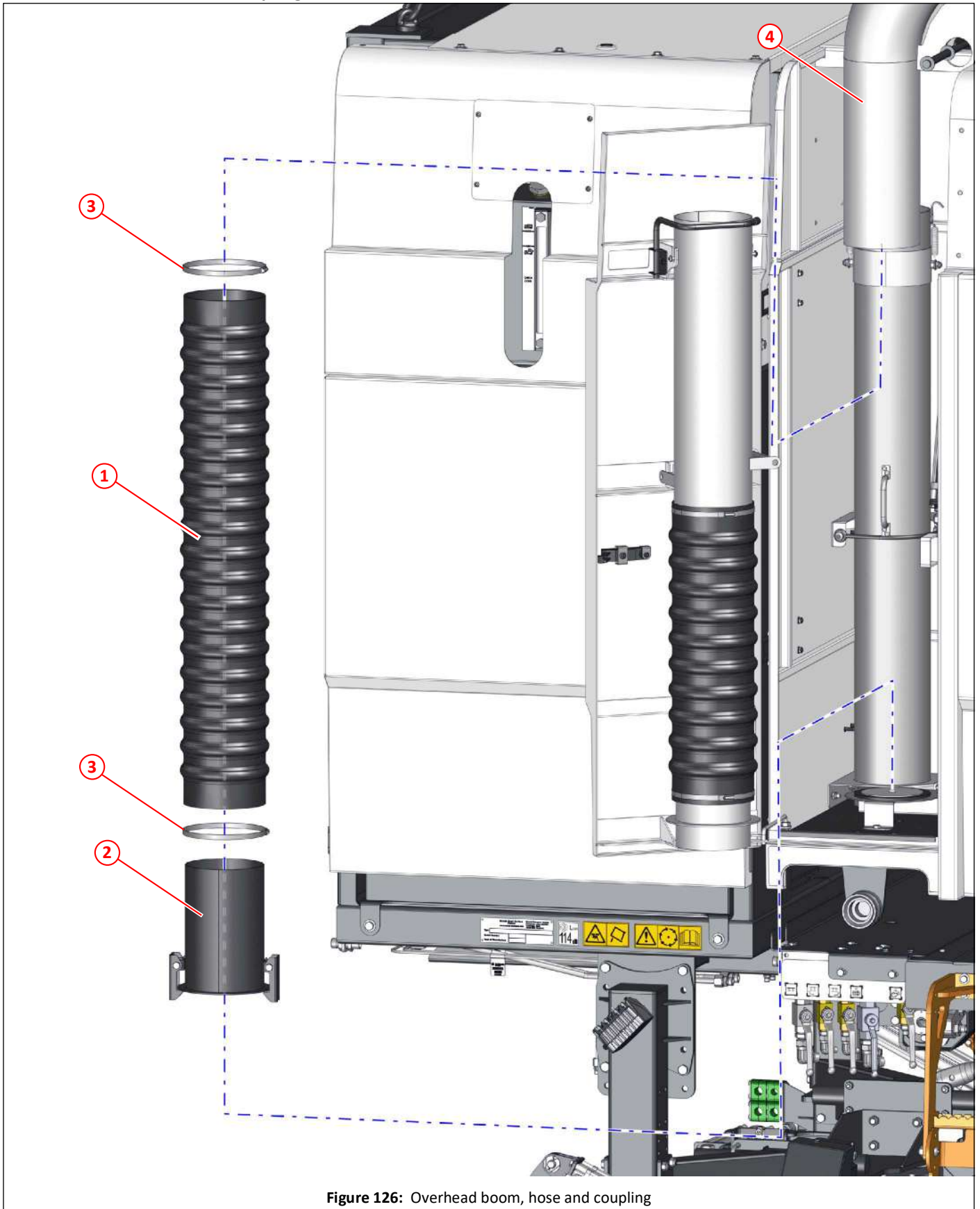

Figure 126: Overhead boom, hose and coupling

Item	Part No	Qty	Description
①	047088	1	Hose 1.025m, overhead boom
②	050988	1	Hose coupling, overhead boom, complete
③	010519	2	Jubilee clip, No 7 (ø135 - ø165)
④	047077	1	Suction pipe with elbow, overhead boom

Overhead boom, coupling

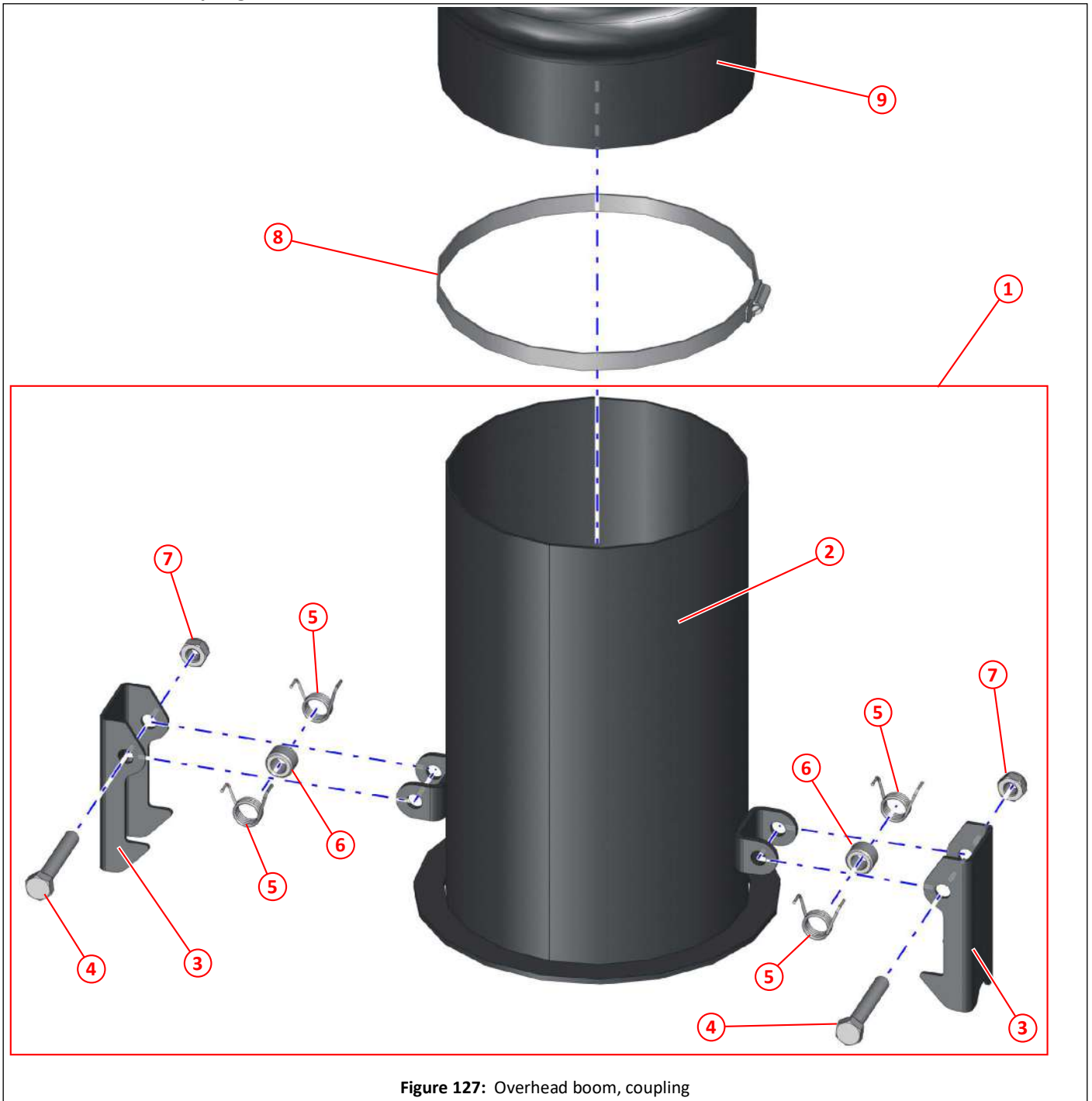

Figure 127: Overhead boom, coupling

Item	Part No	Qty	Description
①	050988	1	Hose coupling, overhead boom, complete
②	044123	1	Hose coupling, overhead boom
③	044125	2	Clamp lever, overhead boom
④	011016	2	Setscrew M8 x 50
⑤	051184	4	Latch spring, overhead boom
⑥	033463	2	Spacer $\phi 15 \times \phi 9 \times 10$
⑦	011073	2	Nyloc nut T M8
⑧	010519	1	Jubilee clip, No 7 ($\phi 135 - \phi 165$)
⑨	047088	1	Hose 1.025m, overhead boom

Overhead boom, coupling stowage bracket

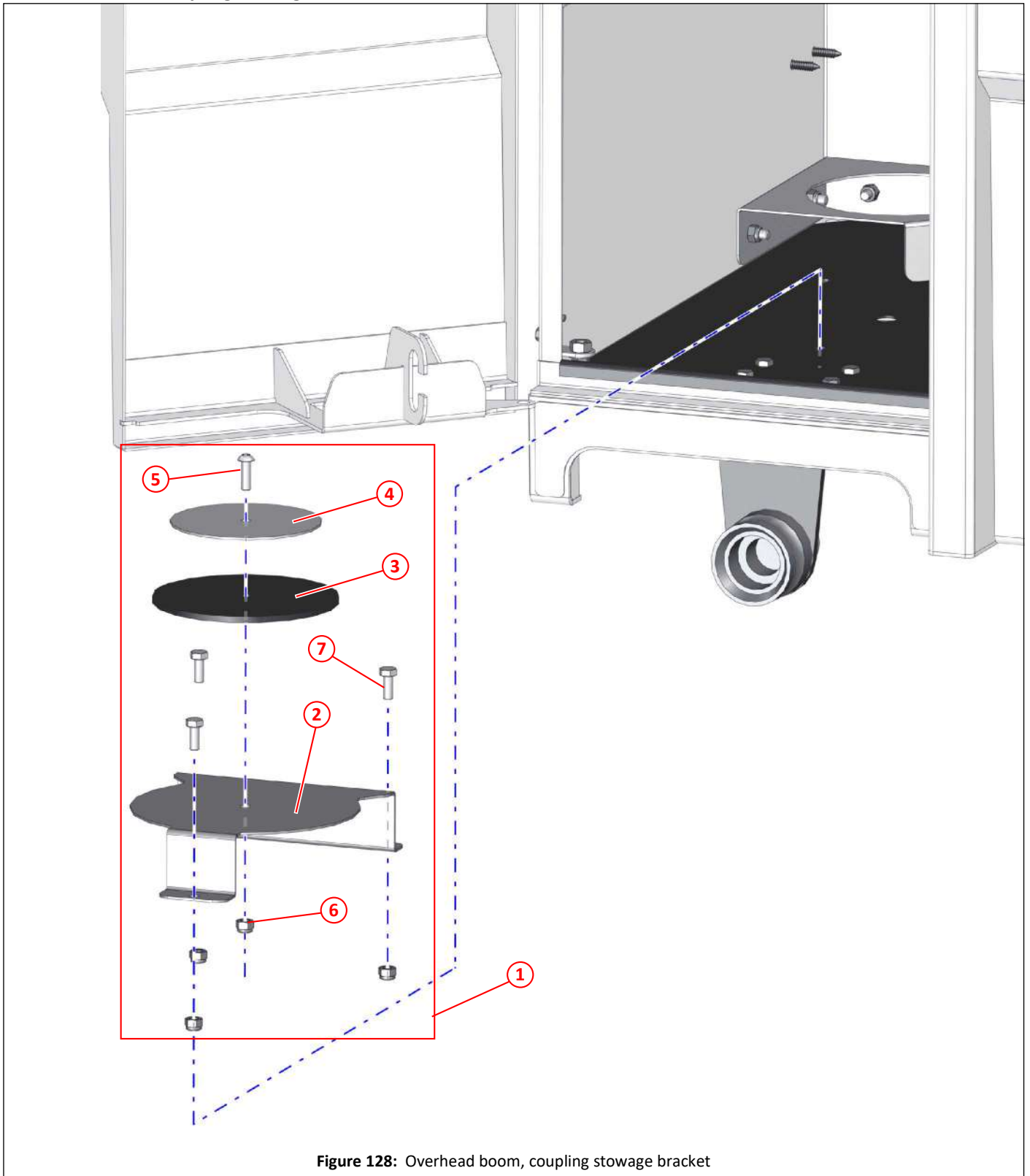

Figure 128: Overhead boom, coupling stowage bracket

Item	Part No	Qty	Description
①	044128	1	Hose coupling stowage, complete
②	044127	1	Bracket, hose coupling stowage
③	044129	1	Rubber sealing disc
④	044130	1	Sealing plate
⑤	000281	1	Socket button head screw M8 x 25, stainless steel
⑥	000263	4	Nyloc nut T M8, stainless steel
⑦	000256	3	Setscrew M8 x 20, stainless steel

Overhead boom, boom extension

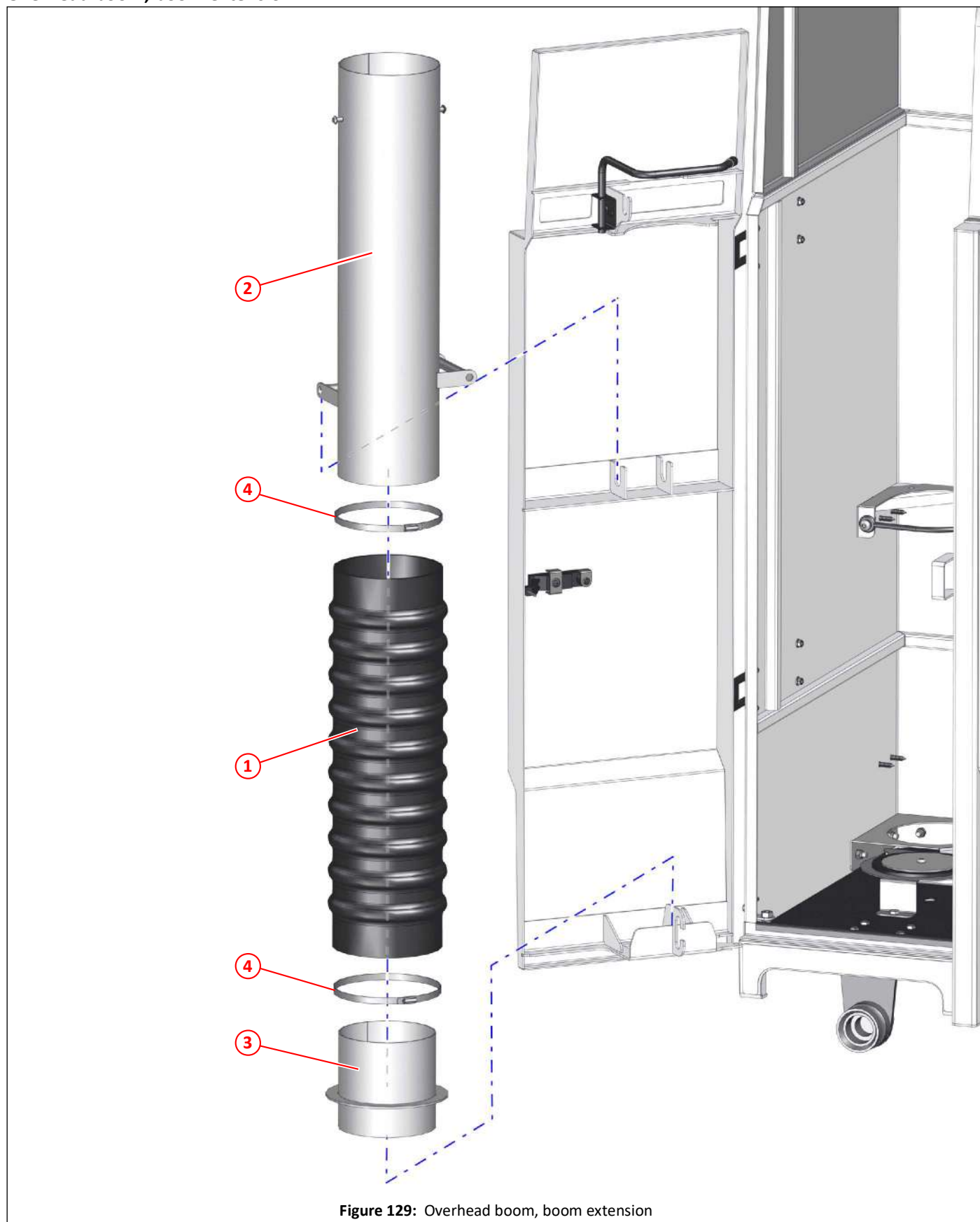

Figure 129: Overhead boom, boom extension

Item	Part No	Qty	Description
①	044106	1	hose, boom extension
②	044141	1	Extension overhead boom
③	044140	1	Hose coupling, overhead boom extension
④	010519	2	Jubilee clip, No 7 (ø135 - ø165)

Overhead boom, boom extension hose saver

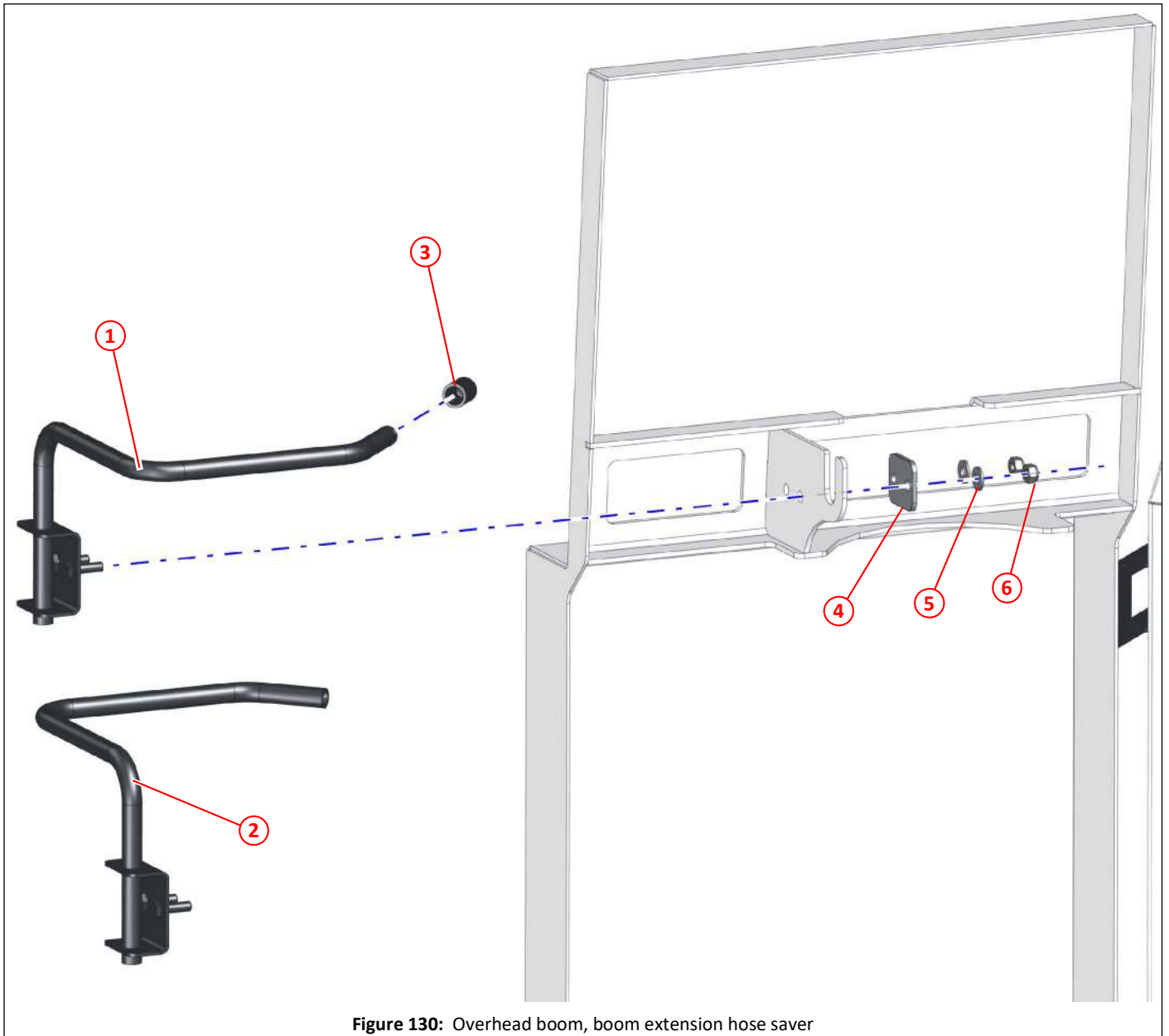

Figure 130: Overhead boom, boom extension hose saver

Item	Part No	Qty	Description
①	045504	1	Hose protector, for left side overhead boom
②	045993	1	Hose protector, for left side overhead boom
③	043065	1	Cap $\varnothing 12$
④	027989	1	Clamp plate
⑤	000254	2	Washer M6, stainless steel
⑥	000253	2	Nyloc nut T M6

Overhead boom, boom extension tube

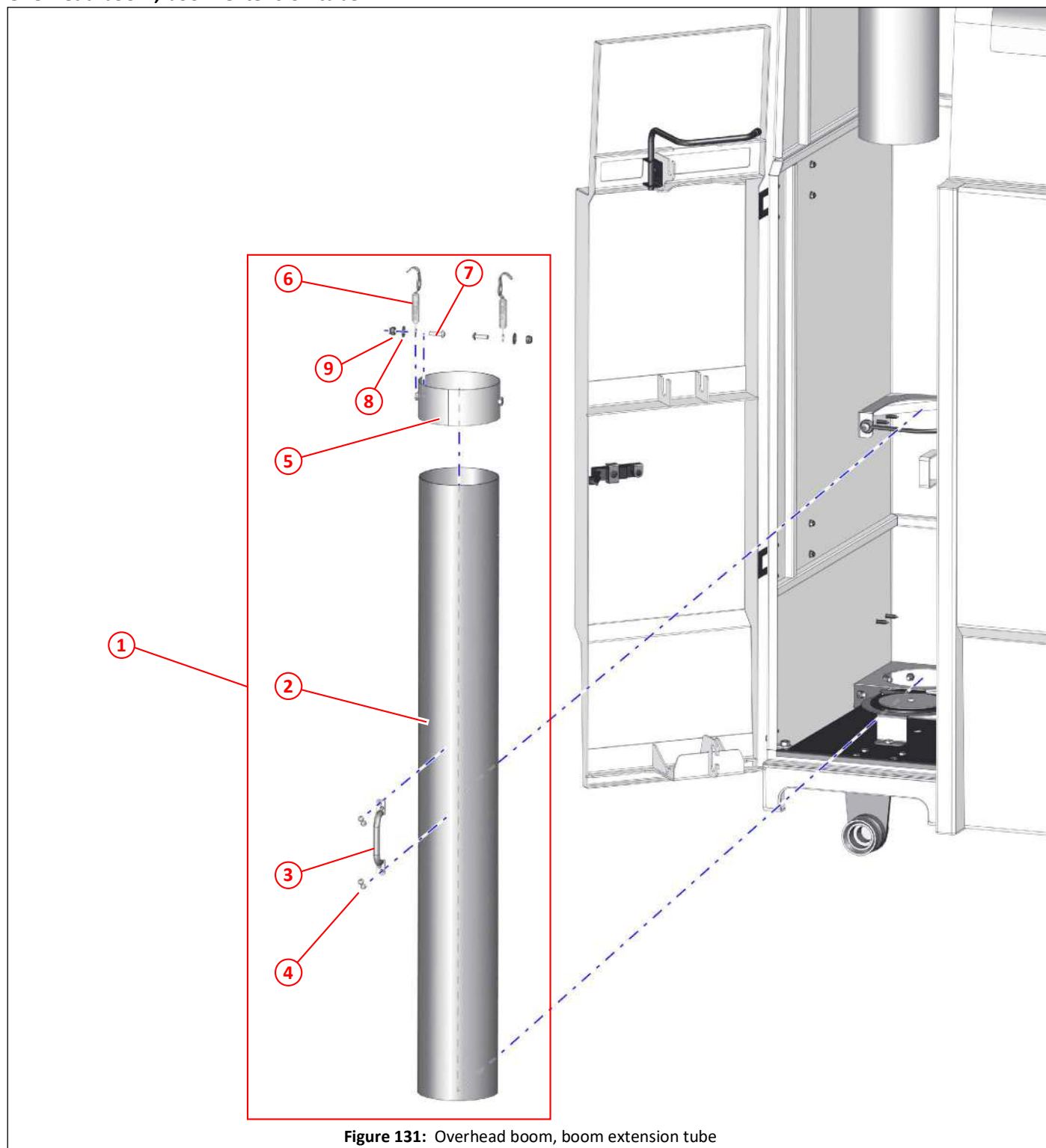

Figure 131: Overhead boom, boom extension tube

Item	Part No	Qty	Description
①	044155	1	Boom extension 1200mm, complete
②	044153	1	Boom extension tube 1200mm
③	010502	1	Pull handle
④	011131	4	Seal blind rivet $\phi 4.8 \times 18$
⑤	044154	1	Boom extension collar
⑥	044014	2	Spring fasteners, stainless steel
⑦	000281	2	Socket button head screw M8 x 25
⑧	000264	2	Washer M8, stainless steel
⑨	000263	2	Nyloc nut T M8, stainless steel

Overhead boom, boom extension tube storage brackets

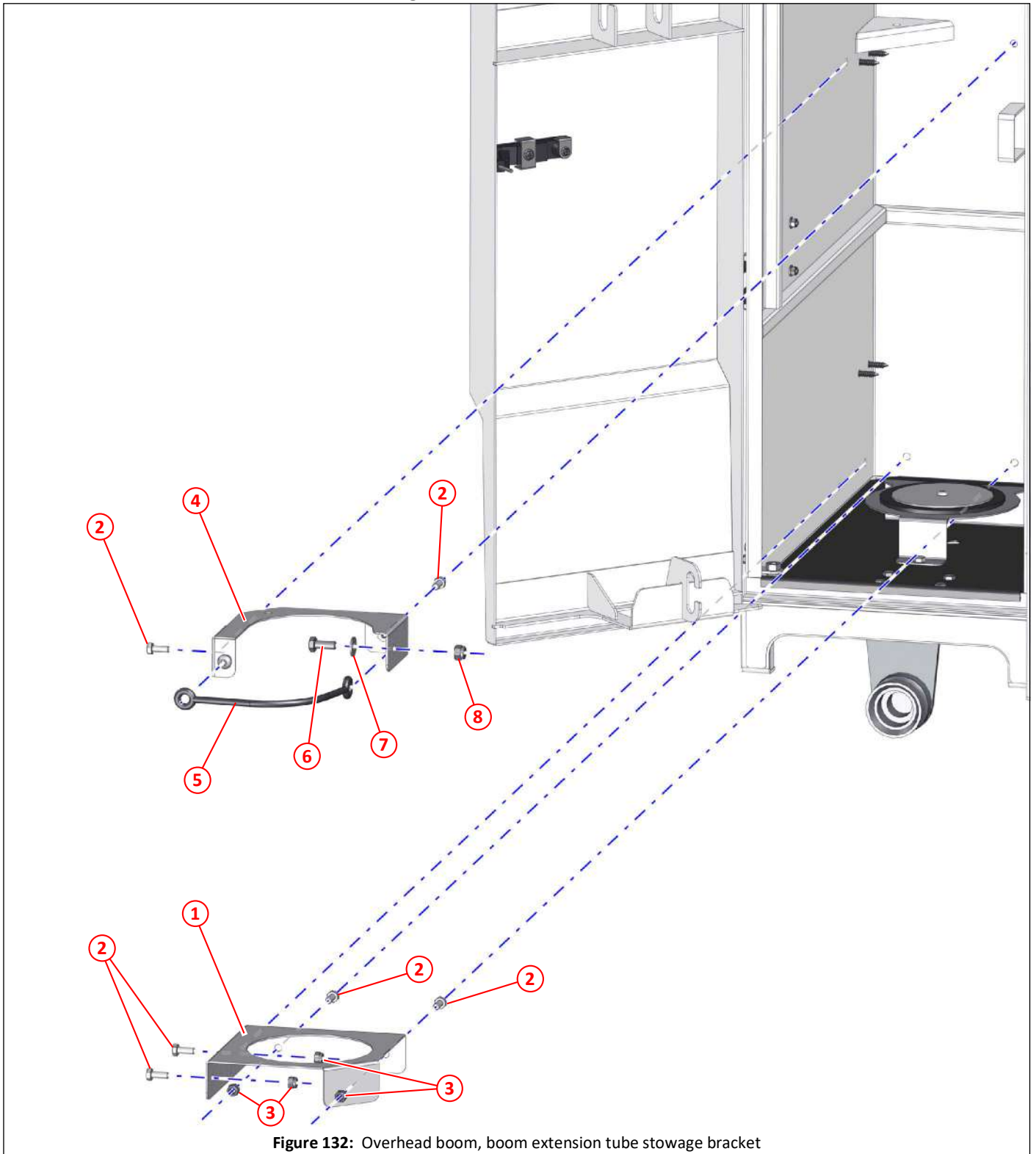

Figure 132: Overhead boom, boom extension tube storage bracket

Item	Part No	Qty	Description
①	044149	1	Stowage bracket lower, boom extension
②	000256	6	Setscrew M8 x 20, stainless steel
③	000263	4	Nyloc nut T M8, stainless steel
④	044717	1	Stowage bracket upper, boom extension
⑤	044007	1	Mini-tye No. 10
⑥	000280	1	Setscrew M10 x 25, stainless steel
⑦	000270	1	Washer M10, stainless steel
⑧	000269	1	Nyloc nut T M10, stainless steel

Suction fan

<i>Description</i>	<i>Page</i>
Suction fan	154
Suction fan motor	156
Suction fan guard	158
Suction fan filter screen	160

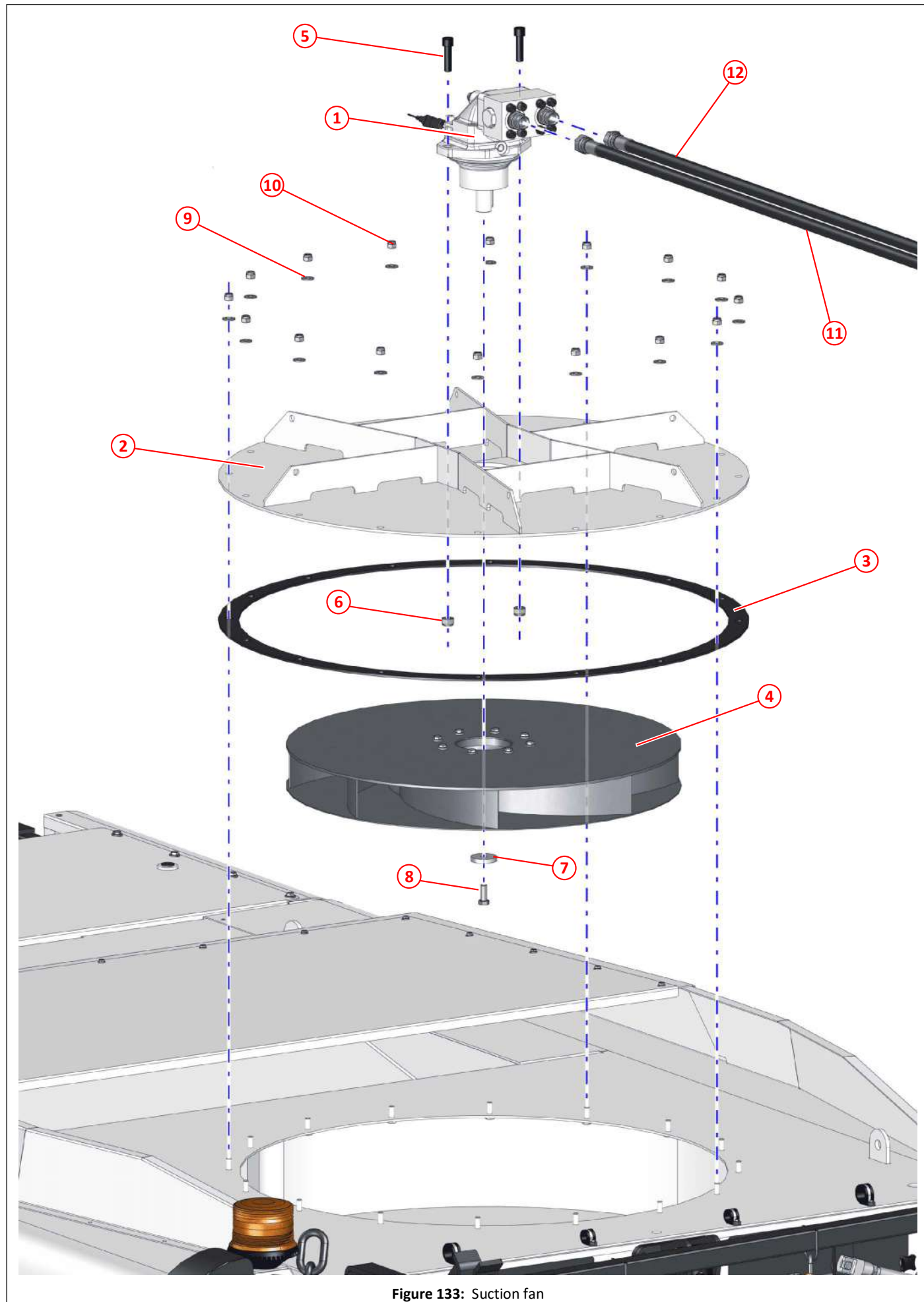
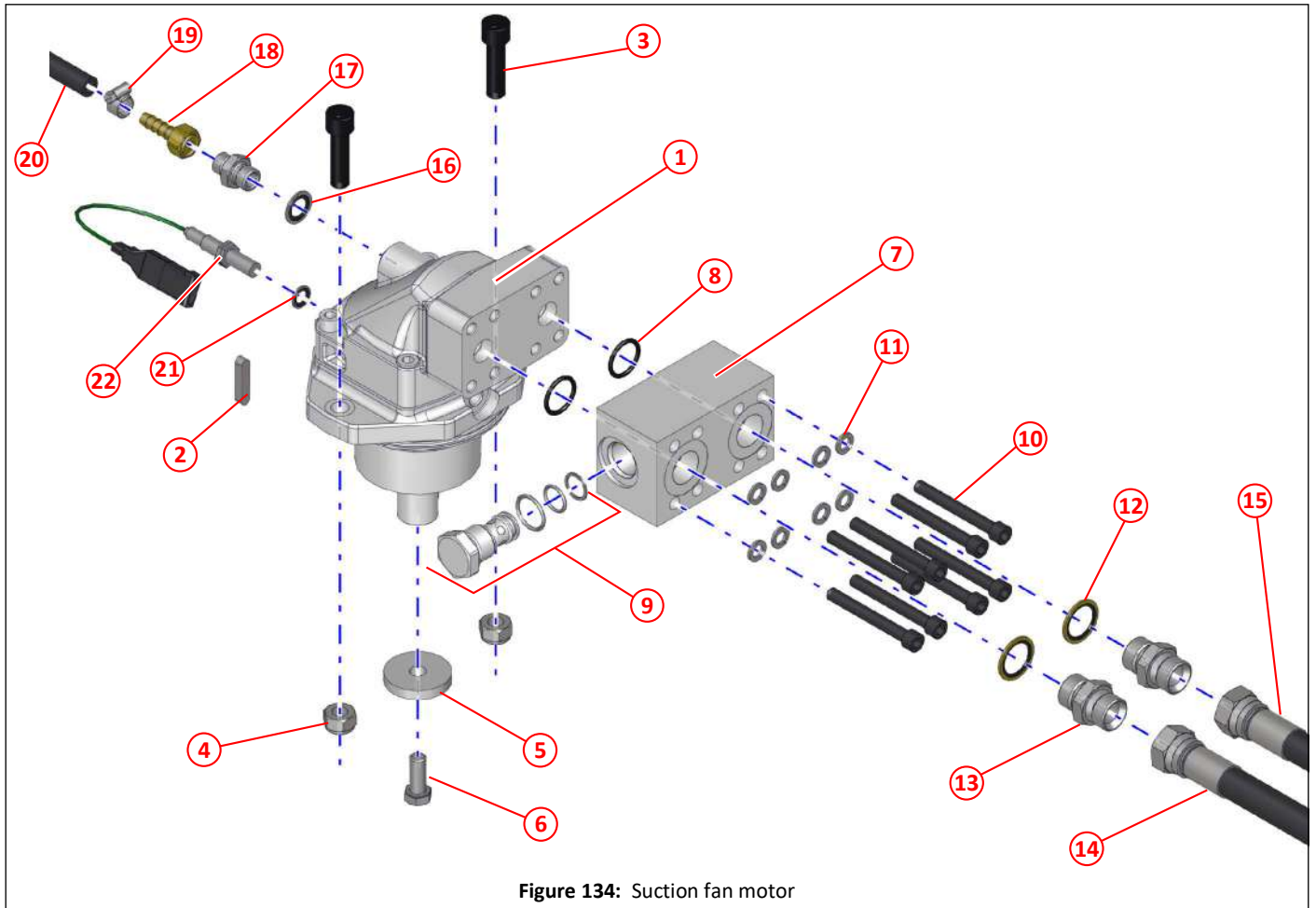

Figure 133: Suction fan

Item	Part No	Qty	Description
①	025564	1	Fan motor assembly
②	041468	1	Fan plate
③	010546	1	Inseal strip 3 x 38
④	041456	1	High speed impeller
⑤	000343	2	Socket cap head bolt M14 x 50, black
⑥	011127	2	Nyloc nut T M14
⑦	044926	1	WASHER ø50 x ø12.5 x 8, stainless steel
⑧	011052	1	Setscrew M12 x 30
⑨	011094	16	Washer M10
⑩	011075	16	Nyloc nut T M10
⑪	001322	1	Hose $\frac{5}{8}$ " x 1550 with $\frac{3}{4}$ " BSP straight ends
⑫	001323	1	Hose $\frac{5}{8}$ " x 1700 with $\frac{3}{4}$ " BSP straight ends

Suction fan motor



Item	Part No	Qty	Description
①	024641	1	Motor F12-030-MF-CH-K-000-000-P
②	013292	1	Key for item ①
③	000343	2	Socket cap head bolt M14 x 50, black
④	011127	2	Nyloc nut T M14
⑤	044926	1	Washer $\phi 50 \times \phi 12.5 \times 8$, stainless steel
⑥	011052	1	Setscrew M12 x 30
⑦	041633 *	1	Manifold
⑧	041634 *	2	'O' ring
⑨	041635 *	1	Check valve HCV12-20, includes seals
⑩	000048	8	Socket cap head screw M10 x 80
⑪	011095	8	Spring washer M10
⑫	011155	2	Dowty seal $\frac{3}{4}$ " BSP
⑬	011161	2	Adapter $\frac{3}{4}$ " BSP
⑭	001322	1	Hose $\frac{5}{8}$ " x 1550 with $\frac{3}{4}$ " BSP straight ends
⑮	001323	1	Hose $\frac{5}{8}$ " x 1700 with $\frac{3}{4}$ " BSP straight ends
⑯	011247	1	Dowty seal M18
⑰	011248	1	Adapter M18 x $\frac{3}{8}$ " BSP
⑱	010921	1	$\frac{3}{8}$ " BSP x $\frac{3}{8}$ " hose end, complete with nut
⑲	010516	1	Hose clip, worm drive, No MOO [$\phi 11$ - $\phi 16$]
⑳	010958	1	Hose, $\frac{3}{8}$ ", fuel, length as required
㉑	011215	1	Dowty seal M12
㉒	025184	1	Speed sensor
*	041564	1	Anti-cavitation valve assembly, includes items ⑦, ⑧ and ⑨

Suction fan guard

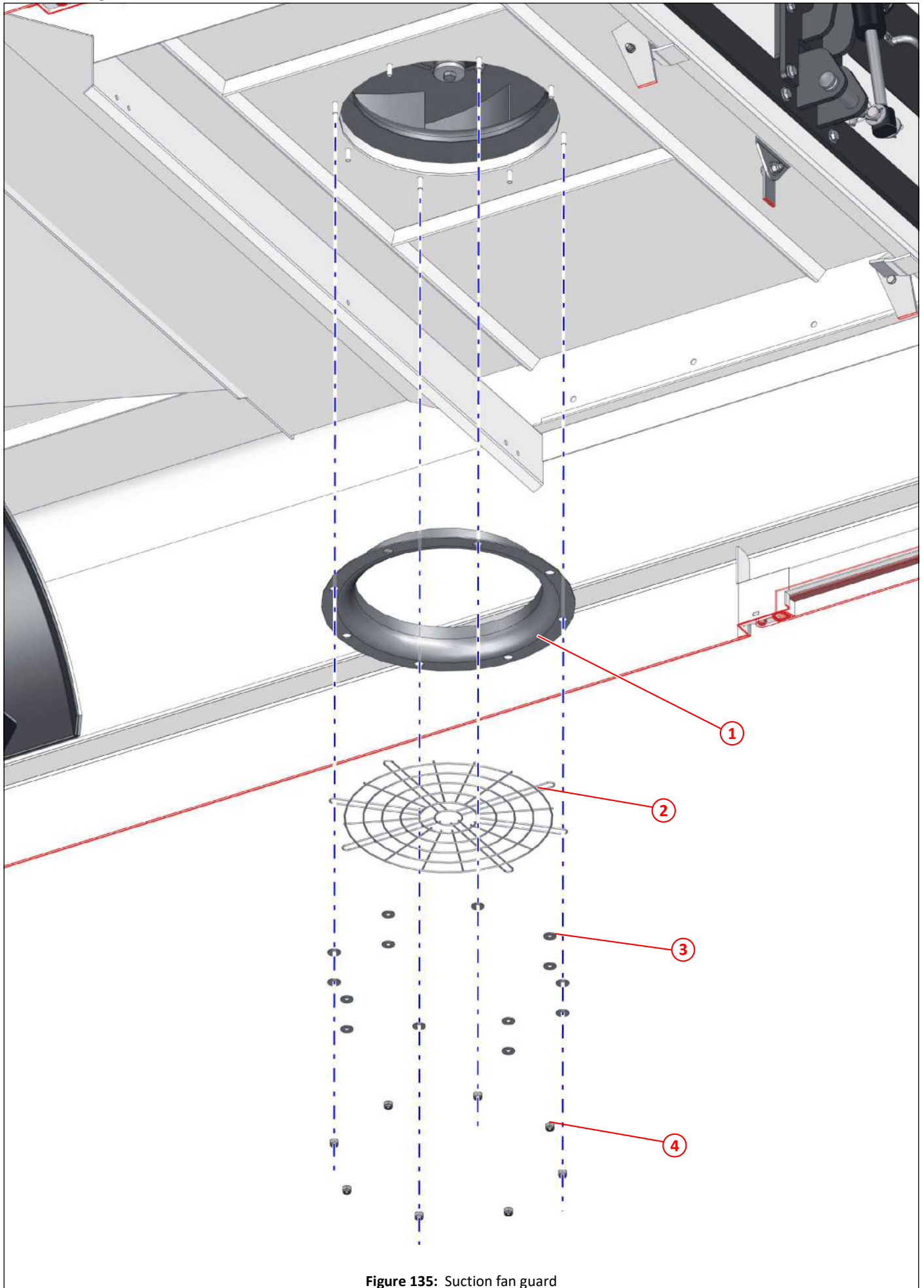

Figure 135: Suction fan guard

Item	Part No	Qty	Description	
①	038568	1	Inlet cone, stainless steel	
②	039674	1	Fan guard	
③	000264	8	Washer M8, stainless steel	
④	000263	8	Nyloc nut T M8, stainless steel	

Suction fan filter screen

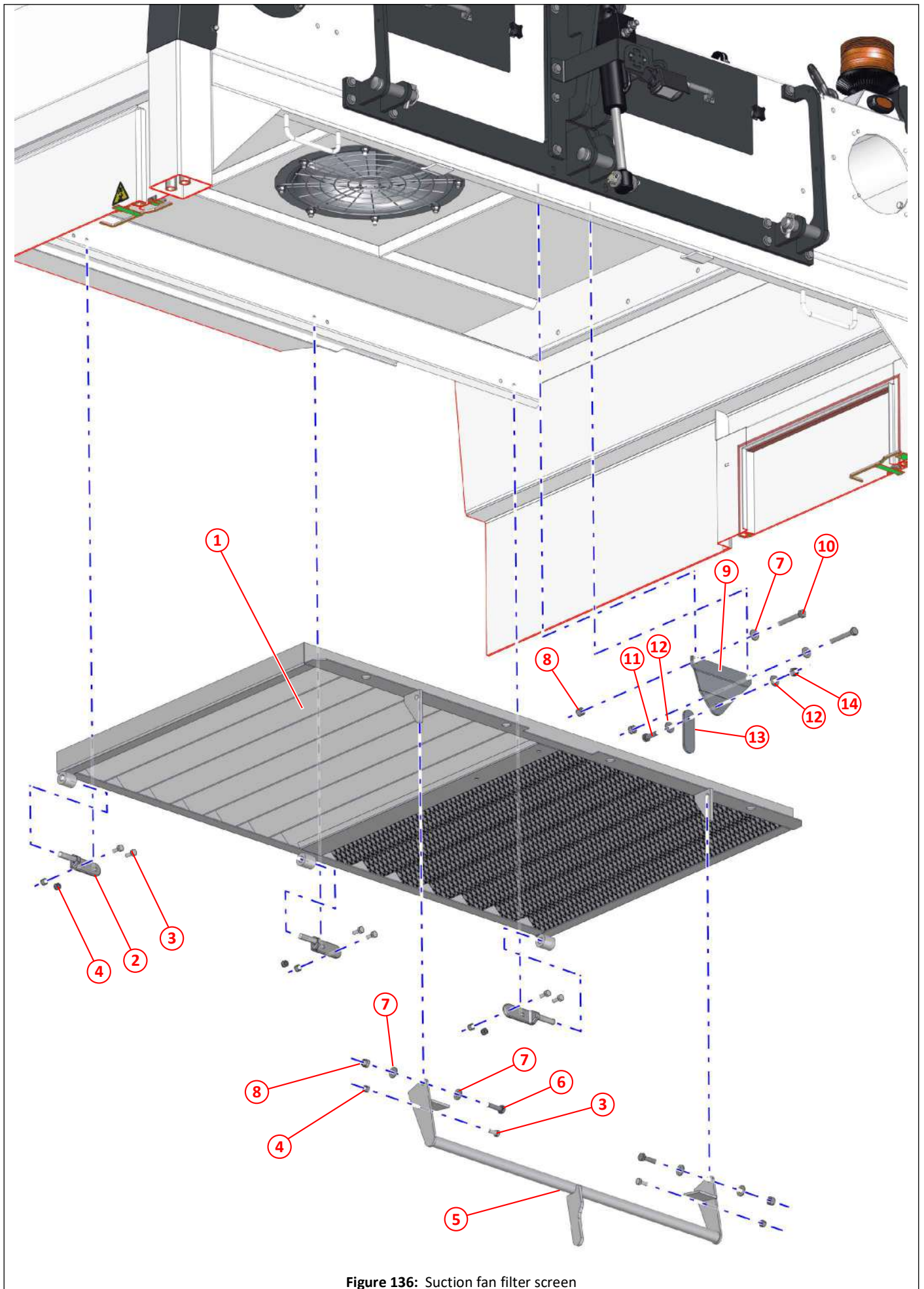

Figure 136: Suction fan filter screen

Item	Part No	Qty	Description	
①	031883	1	Fan filter screen 4000	
②	025245	3	Gudgeon	
③	000256	8	Setscrew M8 x 20, stainless steel	
④	000263	8	Nyloc nut T M8, stainless steel	
⑤	039312	1	Screen latch, long handle	
⑥	000462	2	Setscrew M10 x 35, stainless steel	
⑦	011094	6	Washer M10	
⑧	011075	4	Nyloc nut T M10	
⑨	028052	1	Safety bracket	
⑩	011043	2	Bolt M10 x 70	
⑪	000461	1	Setscrew M10 x 30, stainless steel	
⑫	000270	2	Washer M10, stainless steel	
⑬	028053	1	Safety link	
⑭	000269	1	Nyloc nut T M10, stainless steel	

Hopper and body

<i>Description</i>	<i>Page</i>
Hopper and body arrangement, external	164
Hopper and body arrangement, external	165
Hopper unit	166
Cover lid, hopper	167
Hopper pivot pins and bushes	168
Hopper lift ram mounting	169
Bump stop, hopper safety prop	170
Covers, hopper lockers	171
Locker door, left hand side	172
Locker door, right hand side	173
Hopper access hatch, left hand side	174
Hopper access hatch, right hand side	175
Hopper capping, left hand side	176
Hopper capping, right hand side	177
Hopper LED beacons and rear LED marker lights	178
Hopper lifting eyes, bolts and plugs	179
Hose fixing clips, hopper	180
Cover plate, wander boom hose duct	181
Fan inspection covers, external	182
Fan inspection covers, internal	183
Hopper rear door arrangement	184
Hopper rear door	185
Strainer, tall, rear door	186
Grab handles and cable guides, rear door	187
Warning lights, rear door	188
Warning light, hopper rear right side	189
Warning light, hopper rear left side	190
Rear door strainer outlet, hose version	191
Rear door strainer outlet, valve version	192
Rear door wander hose blanking plate	193
Rear door options brackets	194
Wander hose stowage hooks - Rear door option	195
Direction arrow, when no hose hooks - Rear door option	196
Direction arrow, when hose hooks are used - Rear door option	197
Light Arrow - Rear door option	198
Chapter 8 Reflective chevrons for rear panels	199
Rear door hinge	200
Rear door locking	201
Hopper chute	202
Rear camera	203

Hopper and body arrangement, external

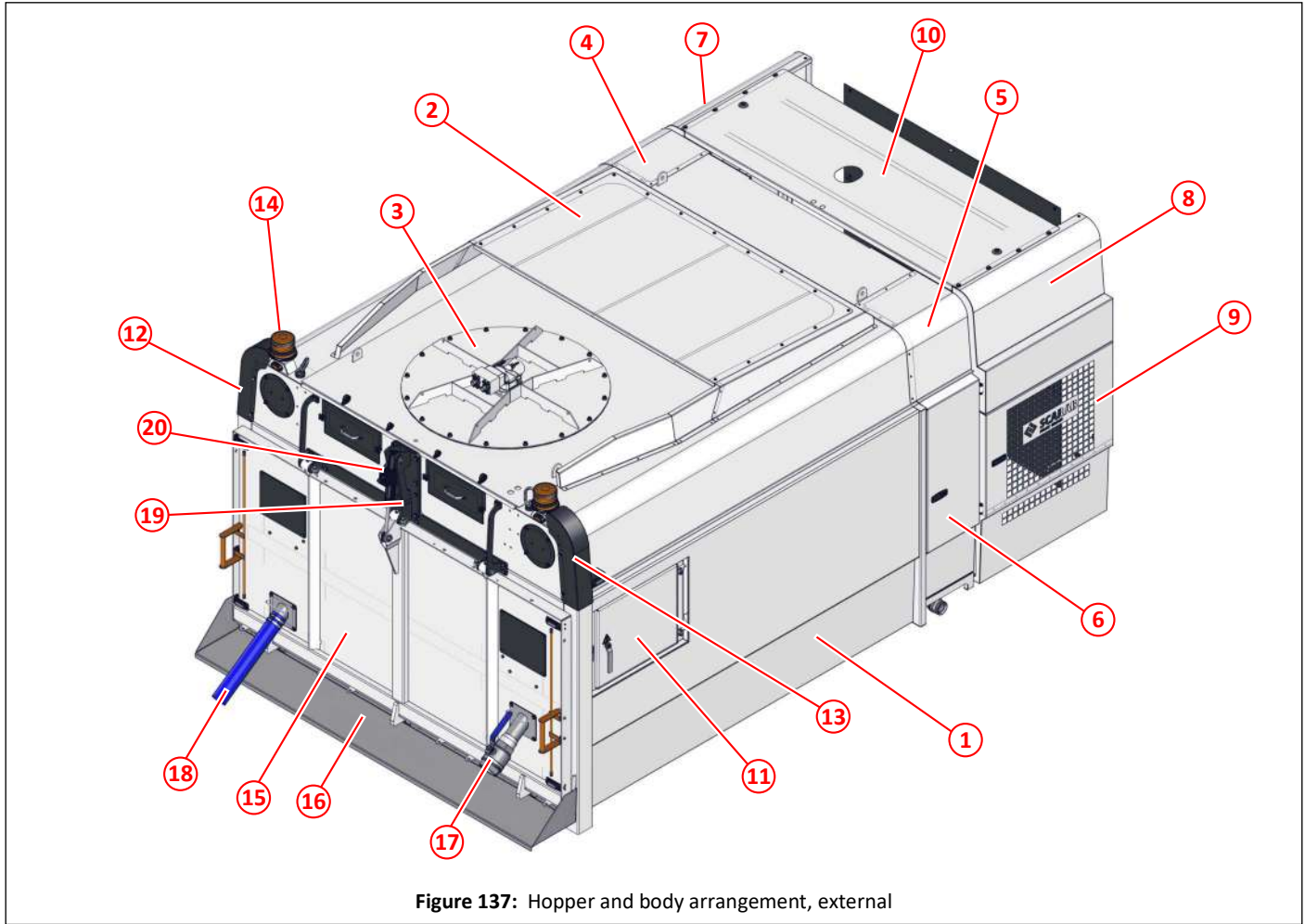

Figure 137: Hopper and body arrangement, external

Item	Part No	Qty	Description	
①	046911	1	Hopper, welded	165,166
②	040042	1	Cover lid, hopper, low line	167
③		1	Suction fan	154
④	044688	1	Cover, hopper locker, left hand side	171
⑤	044689	1	Cover, hopper locker, right hand side	171
⑥	048551	1	Locker door, right hand side	173
⑦	046910	1	Hopper extension wing, oil filler	357
⑧	047367	1	Hopper extension wing, plain	358
⑨	048694	1	Front door, right hand side	360
⑩	048689	1	Roof panel, hopper front	356
⑪	036363	1	Door, side loading hatch	175
⑫	047032	1	Capping, hopper, left hand side	176
⑬	047033	1	Capping, hopper, right hand side	177
⑭	046659	2	LED beacon, single bolt fixing, 10-30V	178
⑮	046850	1	Rear door	184
⑯	046845	1	Hopper chute, large	202
⑰		1	Hopper water drain, valve	192
⑱		1	Hopper water drain, hose	191
⑲		1	Rear door hinge and ram	200,289
⑳			Camera, rear view	203

Hopper and body arrangement, external

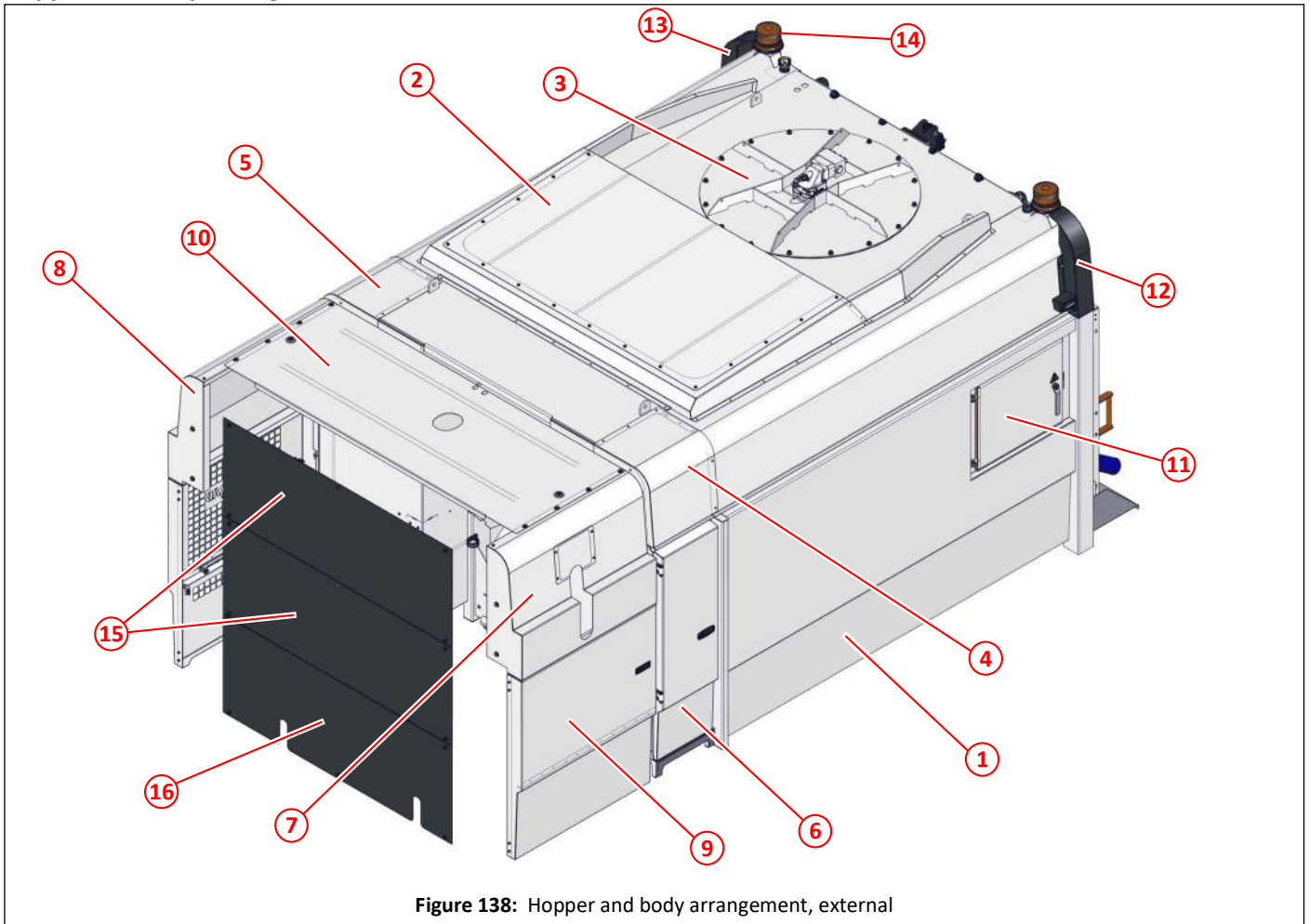

Figure 138: Hopper and body arrangement, external

Item	Part No	Qty	Description	
①	046911	1	Hopper, welded	164,166
②	040042	1	Cover lid, hopper, low line	167
③		1	Suction fan	154
④	044688	1	Cover, hopper locker, left hand side	171
⑤	044689	1	Cover, hopper locker, right hand side	171
⑥	048550	1	Locker door, left hand side	172
⑦	046910	1	Hopper extension wing, oil filler	357
⑧	047367	1	Hopper extension wing, plain	358
⑨	046924	1	Front door, left hand side	359
⑩	048689	1	Roof panel, hopper front	356
⑪	036363	1	Door, side loading hatch	174
⑫	047032	1	Capping, hopper, left hand side	176
⑬	047033	1	Capping, hopper, right hand side	177
⑭	046659	2	LED beacon, single bolt fixing, 10-30V	178
⑮	044867 *	2	End panel	361
⑯	043464	1	End panel, for use if auxiliary water tank fitted	361

*. If an auxiliary water tank is not fitted then the quantity will be 3.

Hopper unit

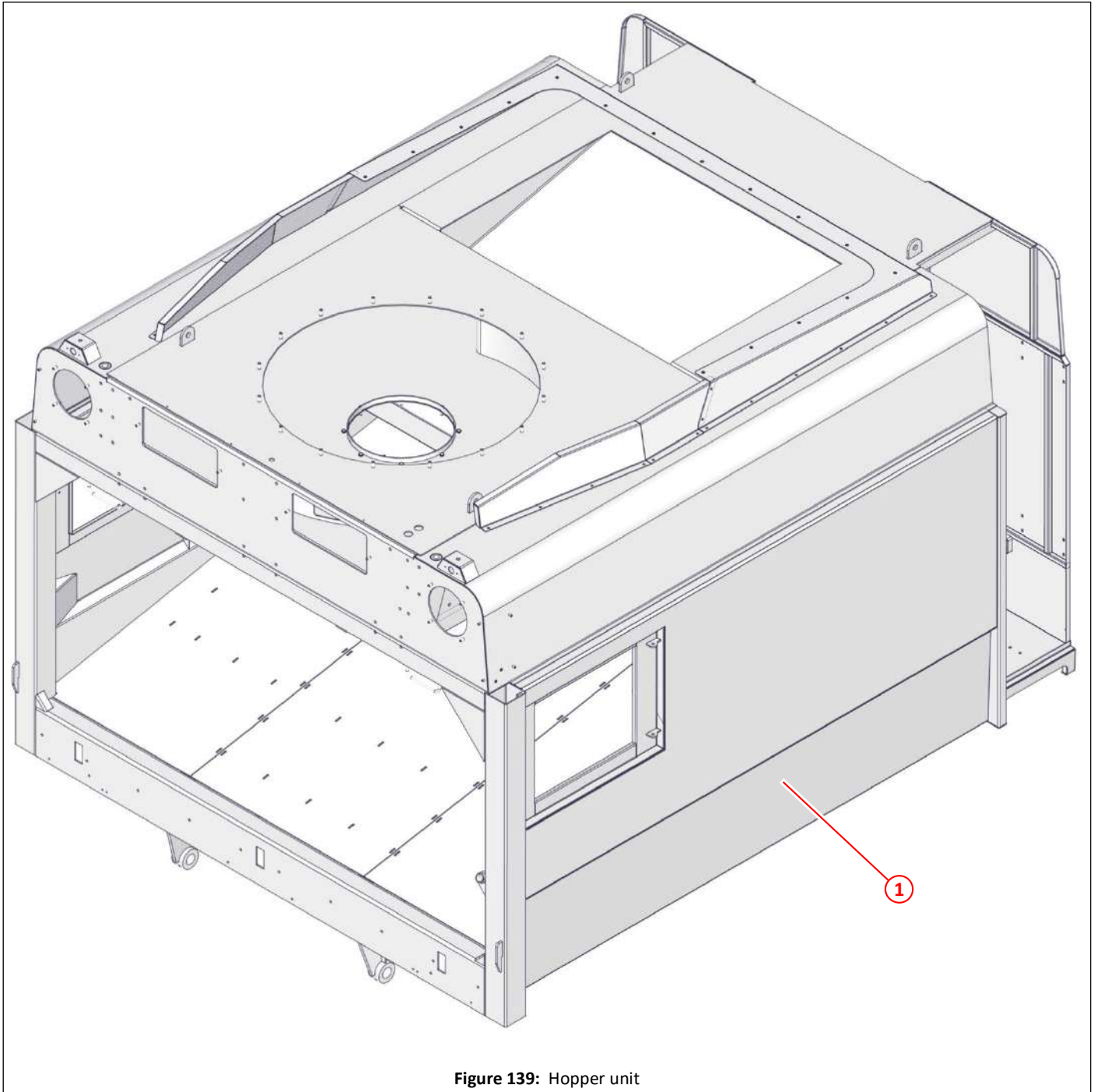

Figure 139: Hopper unit

Item	Part No	Qty	Description	
①	046911	1	Hopper, welded	164,165

Cover lid, hopper

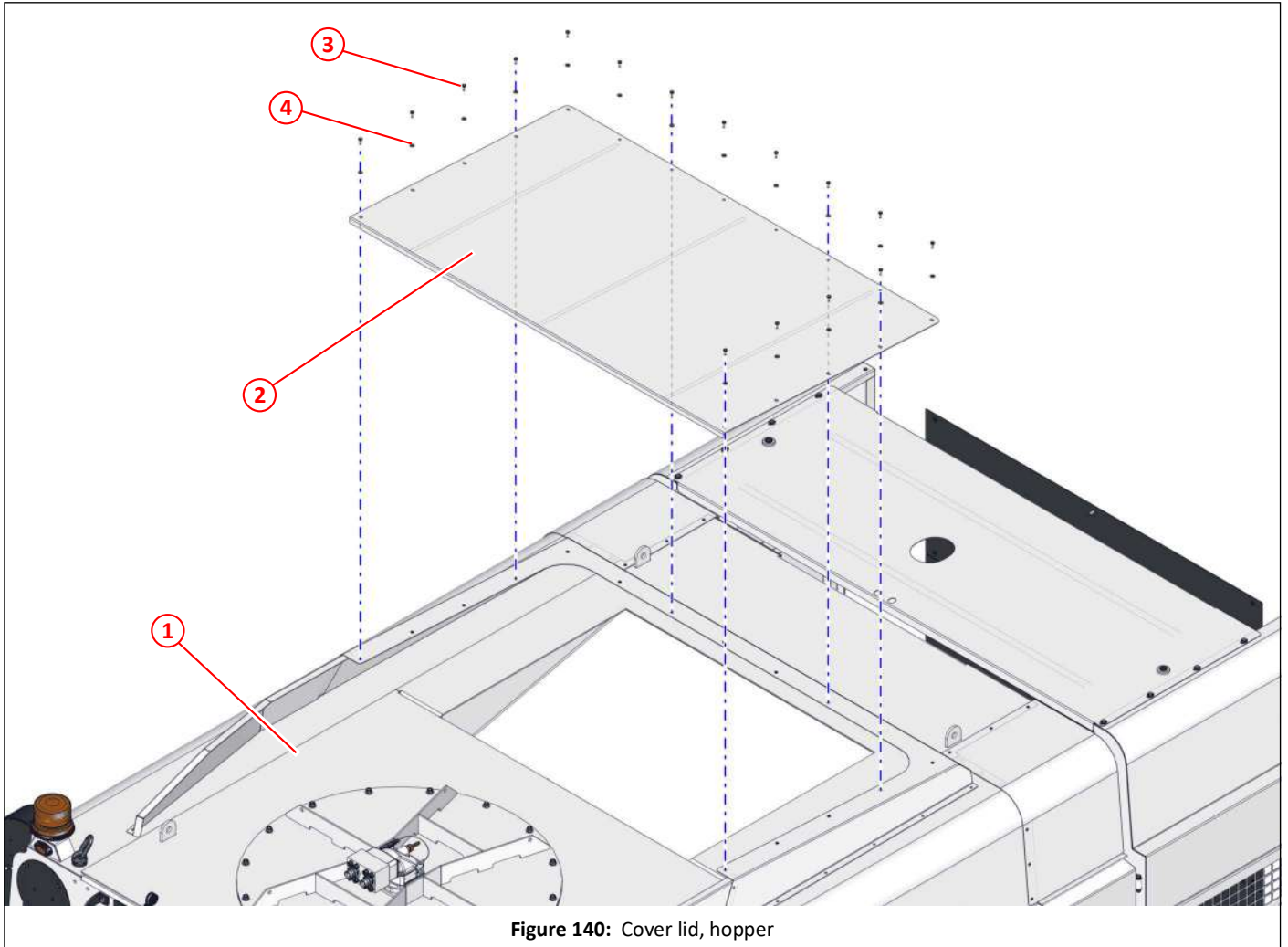

Figure 140: Cover lid, hopper

Item	Part No	Qty	Description	
①	046911	1	Hopper, welded	164,165,166
②	040042	1	Cover lid, hopper, low line	
③	011001	16	Setscrew HT M6 x 16	
④	011090	16	Washer M6	

Hopper pivot pins and bushes

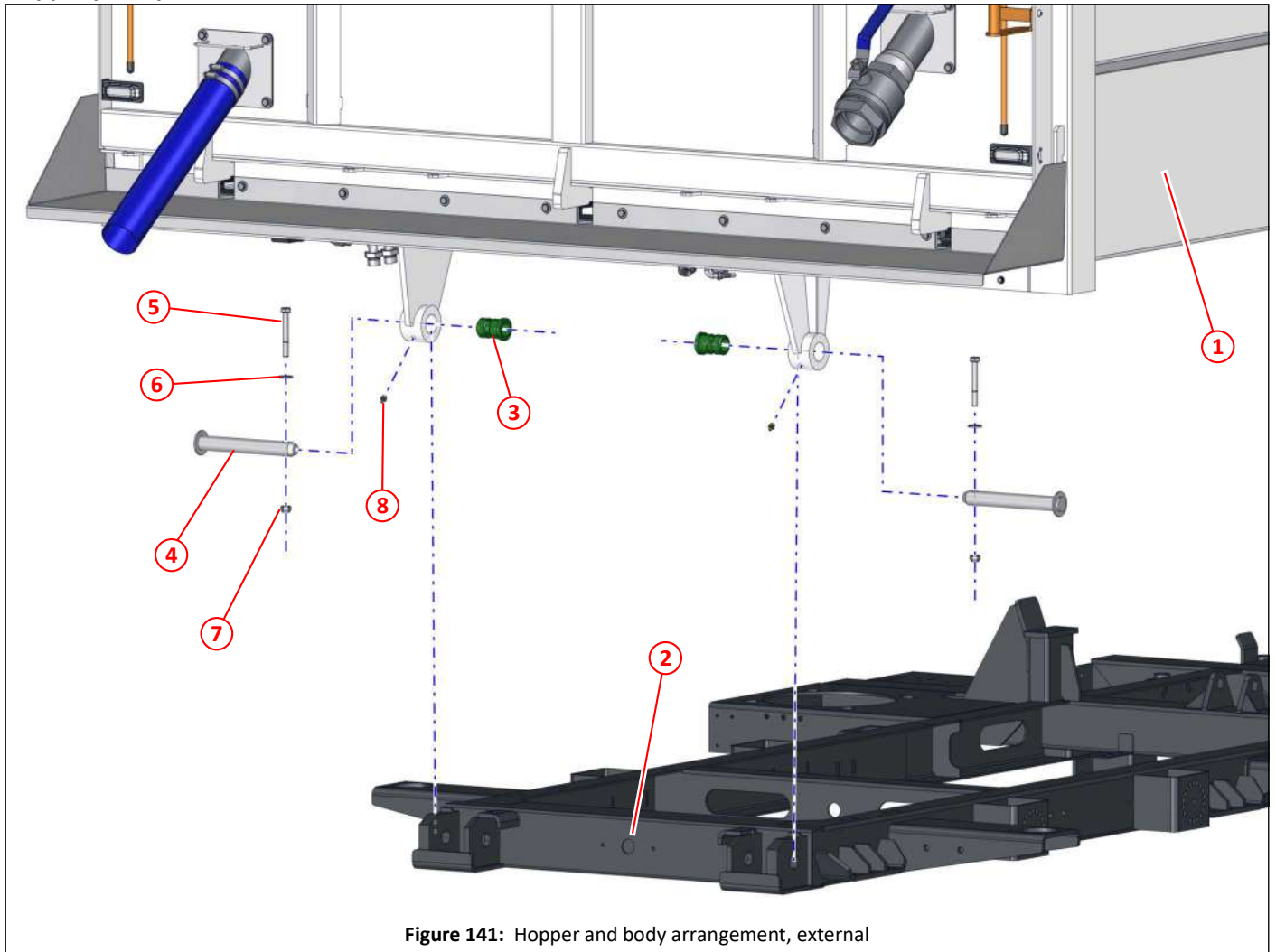

Figure 141: Hopper and body arrangement, external

Item	Part No	Qty	Description	
①	046911	1	Hopper, welded	164,165,166
②	042942	1	Subframe	
③	020336	2	Bush	
④	034391	2	Pivot, hopper	
⑤	000139	2	Bolt M12 x 90 (10.9)	
⑥	011096	2	Washer M12	
⑦	011077	2	Nyloc nut T M12	
⑧	010903	2	Grease nipple, straight, $\frac{1}{8}$ " BSP	

Hopper lift ram mounting

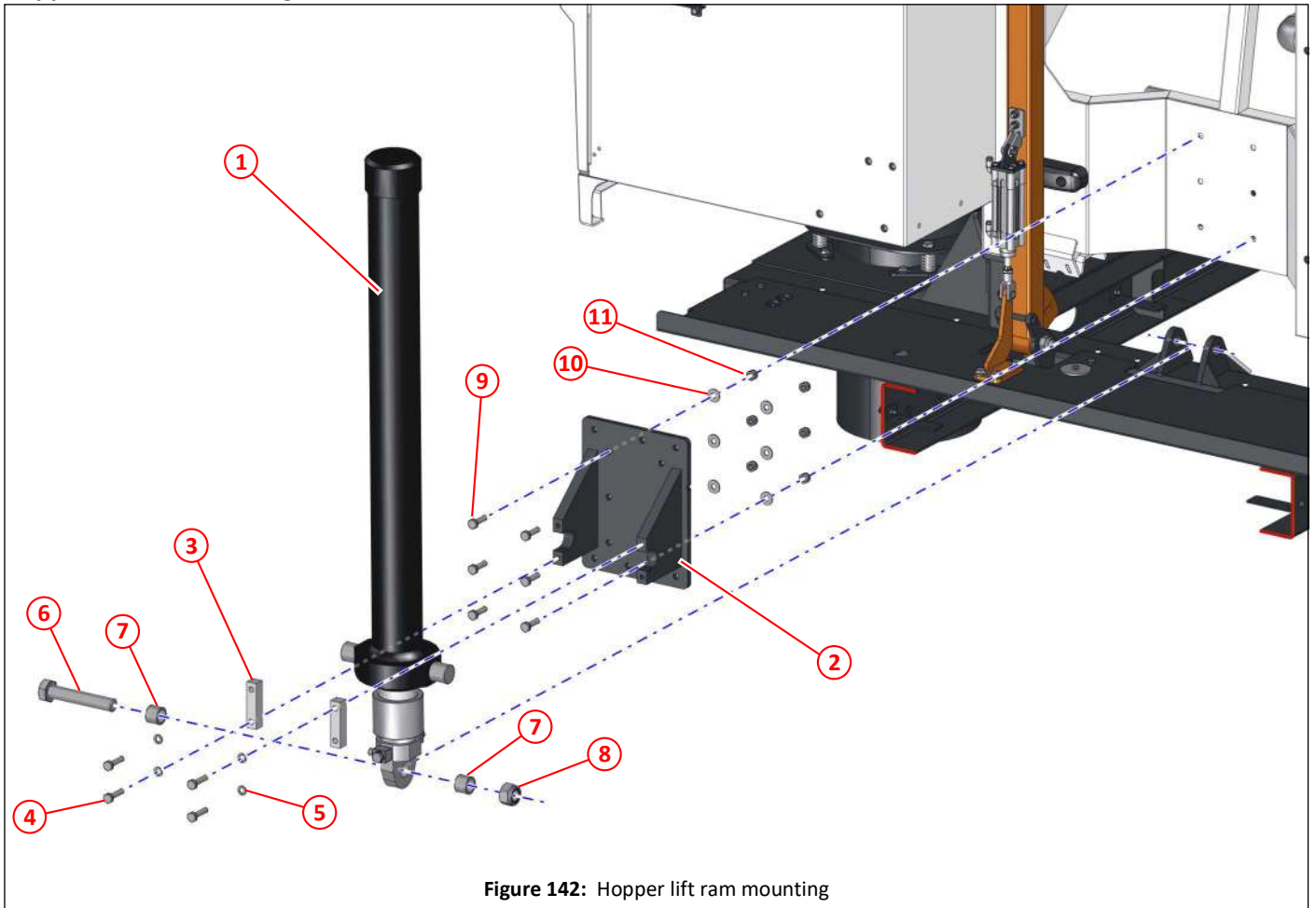

Figure 142: Hopper lift ram mounting

Item	Part No	Qty	Description	
①	024249	1	Ram, dual acting, hopper lift	288
②	010719	1	Pivot, hopper lift ram	
③	034395	2	Pivot bar, hopper lift ram	
④	011034	4	Setscrew M10 x 40	
⑤	011095	4	Spring washer M10	
⑥	000241	1	Bolt HT M24 x 130	
⑦	013714	2	Spacer, hopper lift ram	
⑧	000008	1	Nyloc nut T M24	
⑨	011033	6	Setscrew HT M10 x 35	
⑩	011094	6	Washer M10	
⑪	011075	6	Nyloc nut T M10	

Bump stop, hopper safety prop

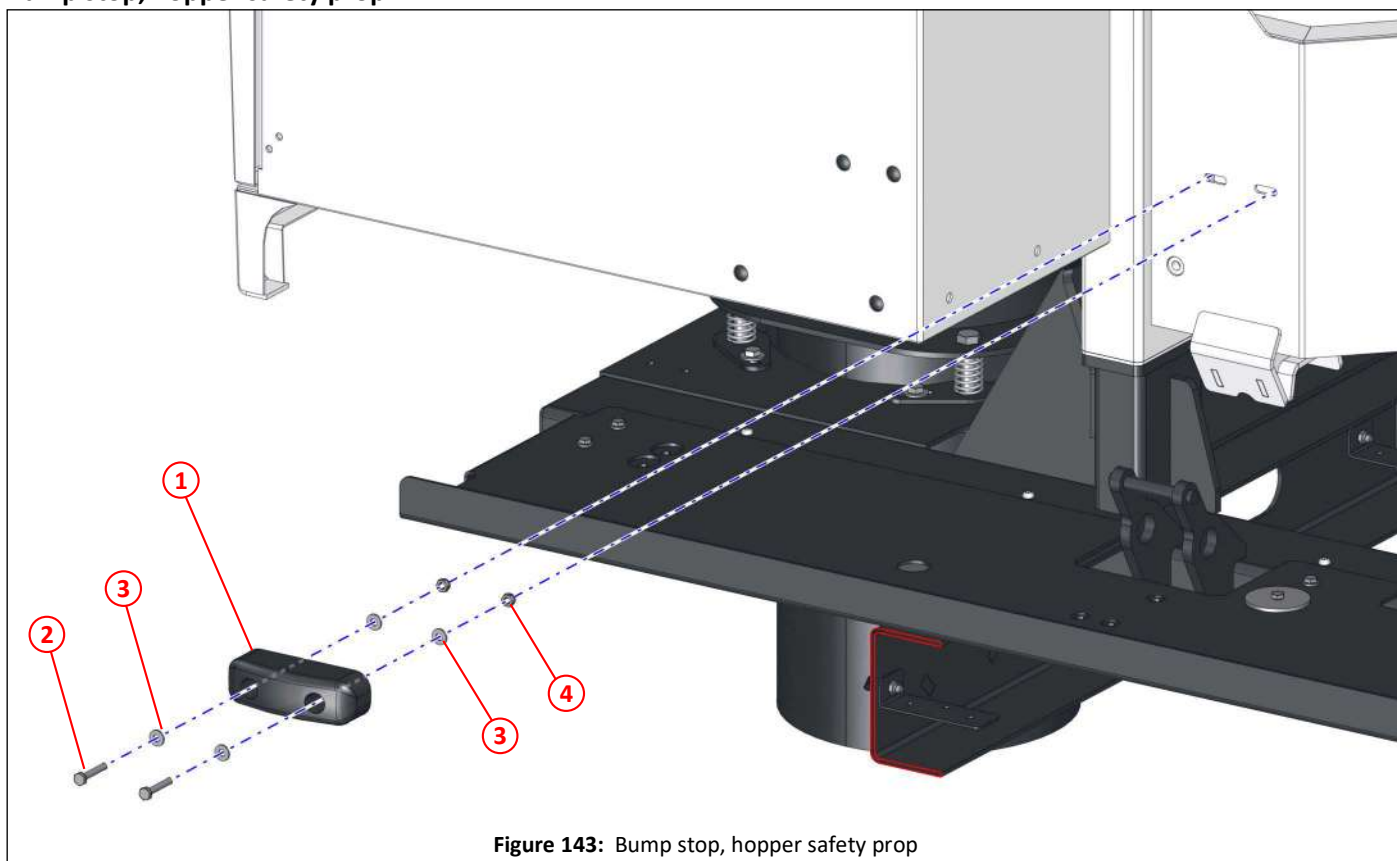

Figure 143: Bump stop, hopper safety prop

Item	Part No	Qty	Description
①	013466	1	Rubber buffer
②	011068	2	Bolt HT M6 x 35
③	011090	4	Washer M6
④	011071	2	Nyloc nut T M6

Covers, hopper lockers

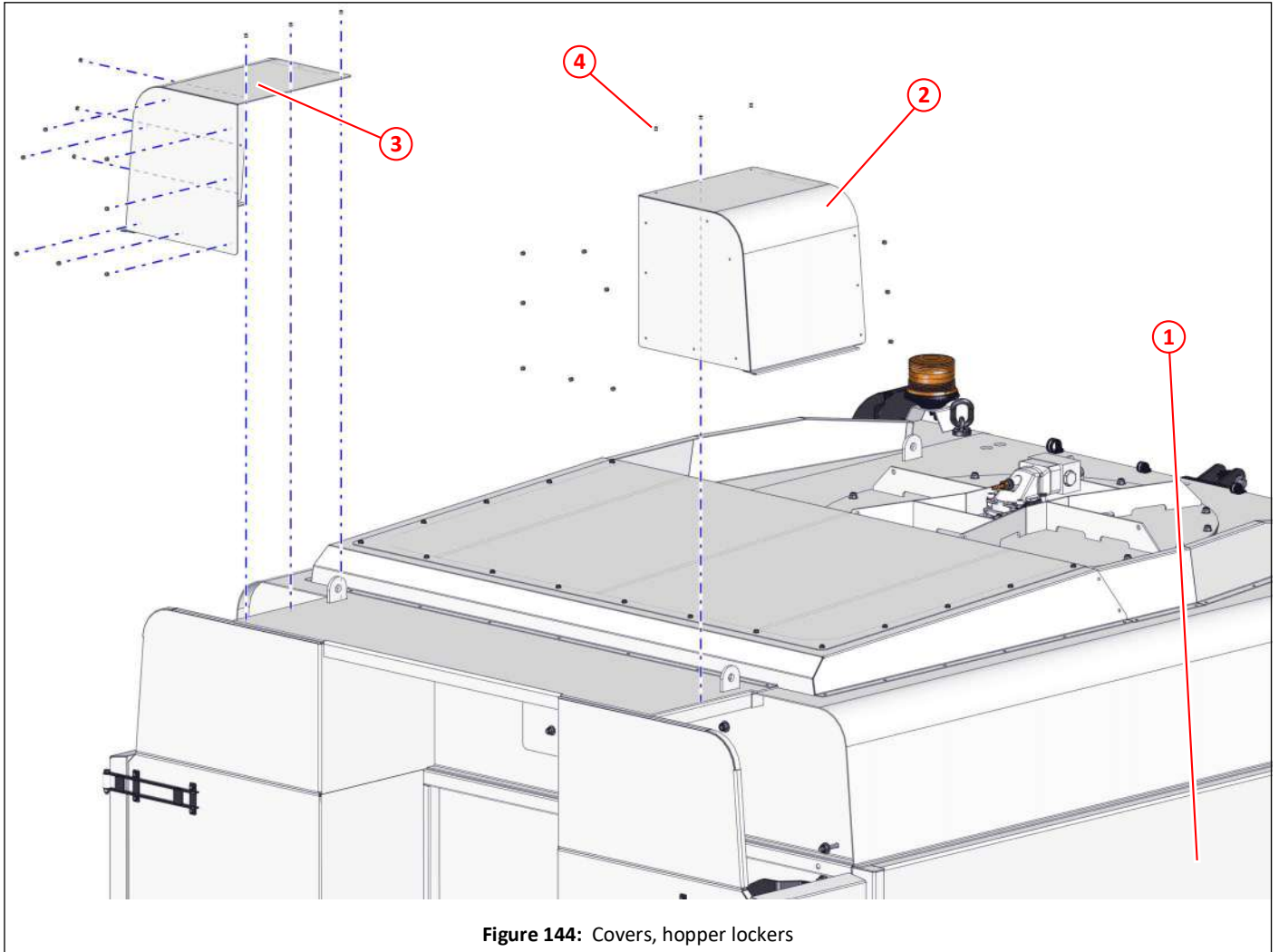

Figure 144: Covers, hopper lockers

Item	Part No	Qty	Description	
①	046911	1	Hopper, welded	164,165,166
②	044688	1	Cover, hopper locker, left hand side	
③	044689	1	Cover, hopper locker, right hand side	
④	011131	26	Seal blind rivet $\varnothing 4.8 \times 18$	

Locker door, left hand side

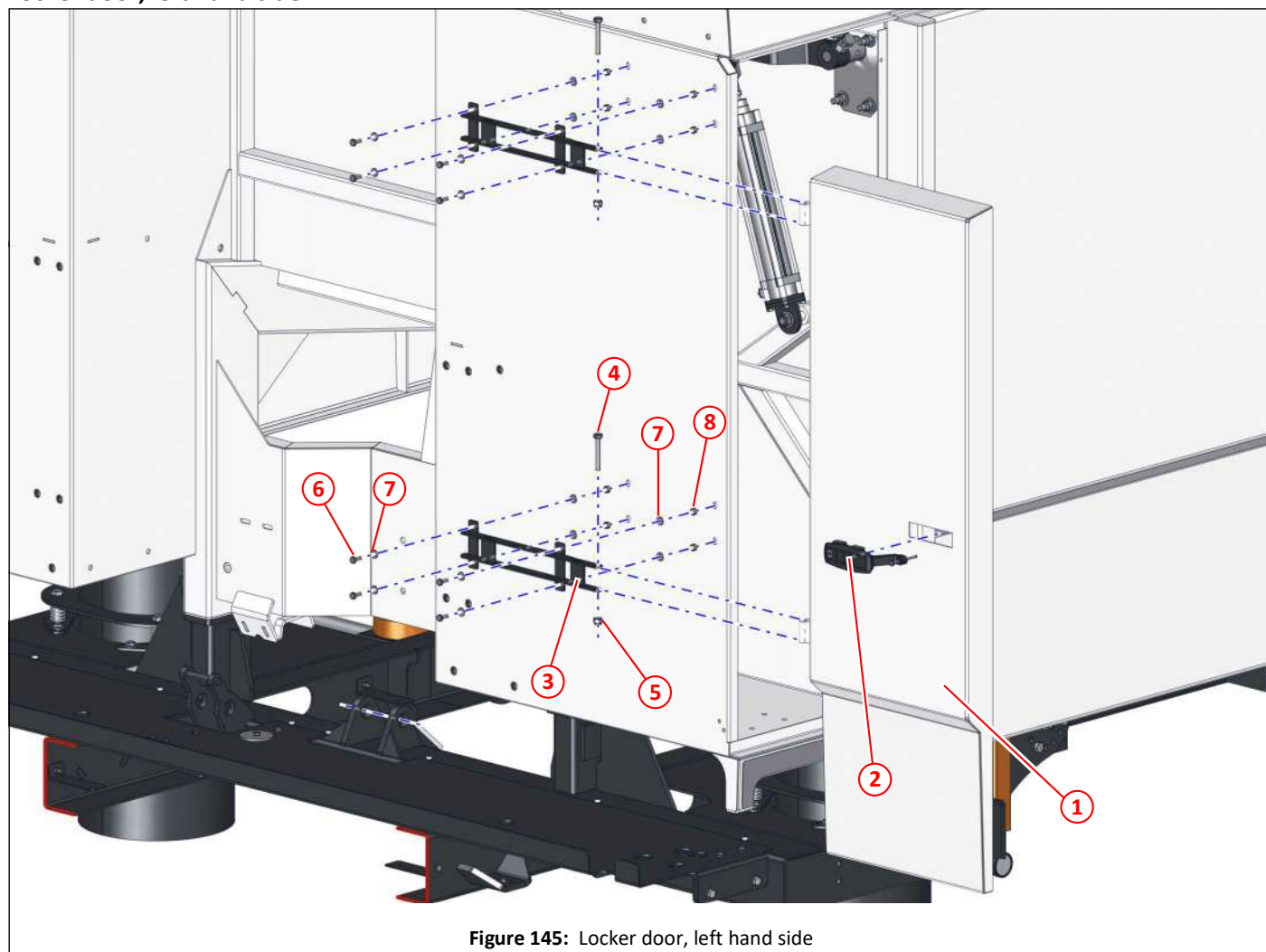

Figure 145: Locker door, left hand side

Item	Part No	Qty	Description
①	048550	1	Locker door, left hand side
②	033115	1	Latch, locking, flush compression
③	048040	2	Hinge, locker door
④	000261	2	Bolt M8 x 55, stainless steel
⑤	000263	2	Nyloc nut T M8, stainless steel
⑥	000250	8	Setscrew M6 x 16, stainless steel
⑦	000254	16	Washer M6, stainless steel
⑧	000253	8	Nyloc nut T M6, stainless steel

Locker door, right hand side

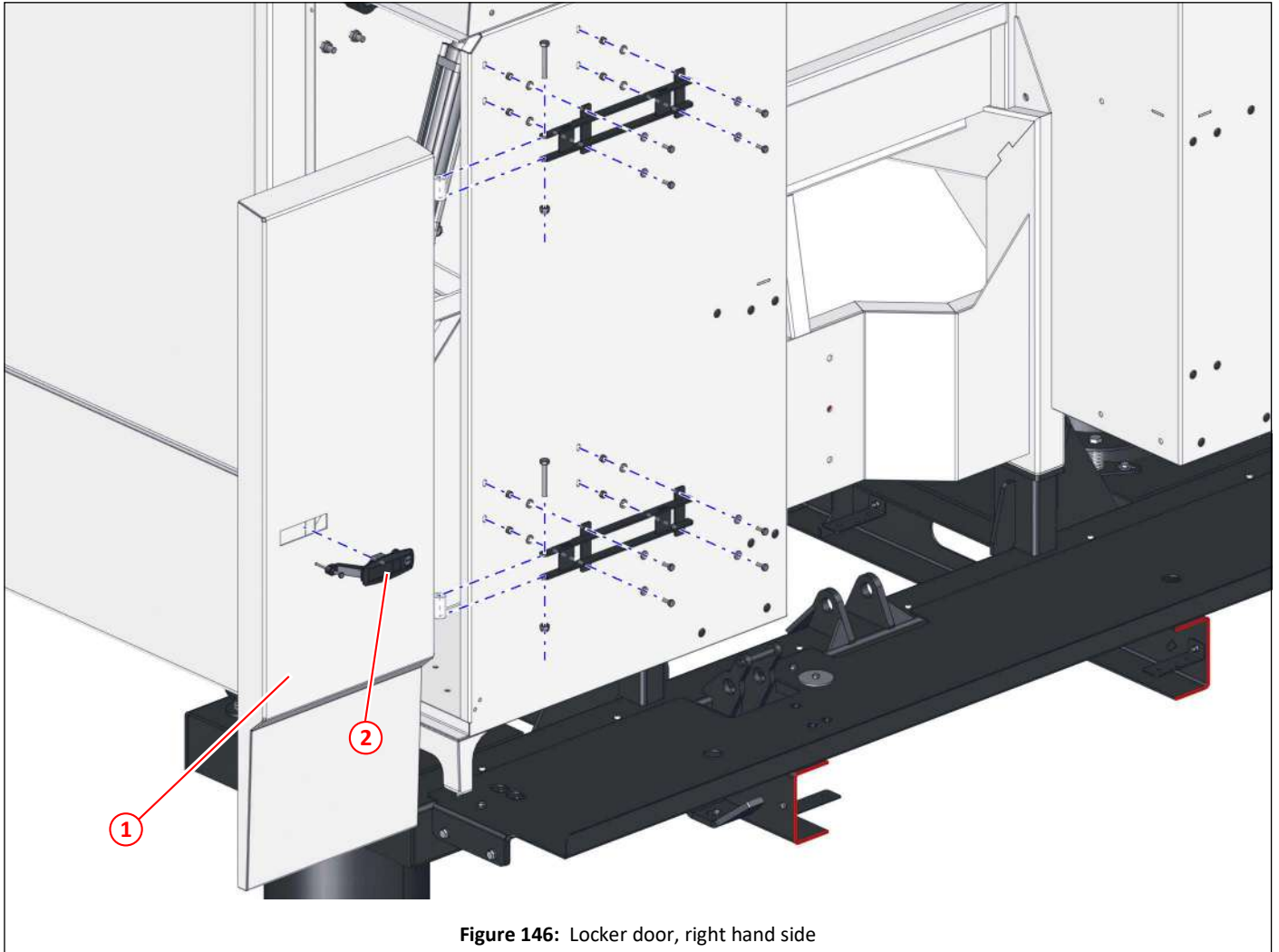

Figure 146: Locker door, right hand side

Item	Part No	Qty	Description	
①	048551	1	Locker door, right hand side	
②	033115	1	Latch, locking, flush compression	
③	048040	2	Hinge, locker door	
④	000261	2	Bolt M8 x 55, stainless steel	
⑤	000263	2	Nyloc nut T M8, stainless steel	
⑥	000250	8	Setscrew M6 x 16, stainless steel	
⑦	000254	16	Washer M6, stainless steel	
⑧	000253	8	Nyloc nut T M6, stainless steel	

Hopper access hatch, left hand side

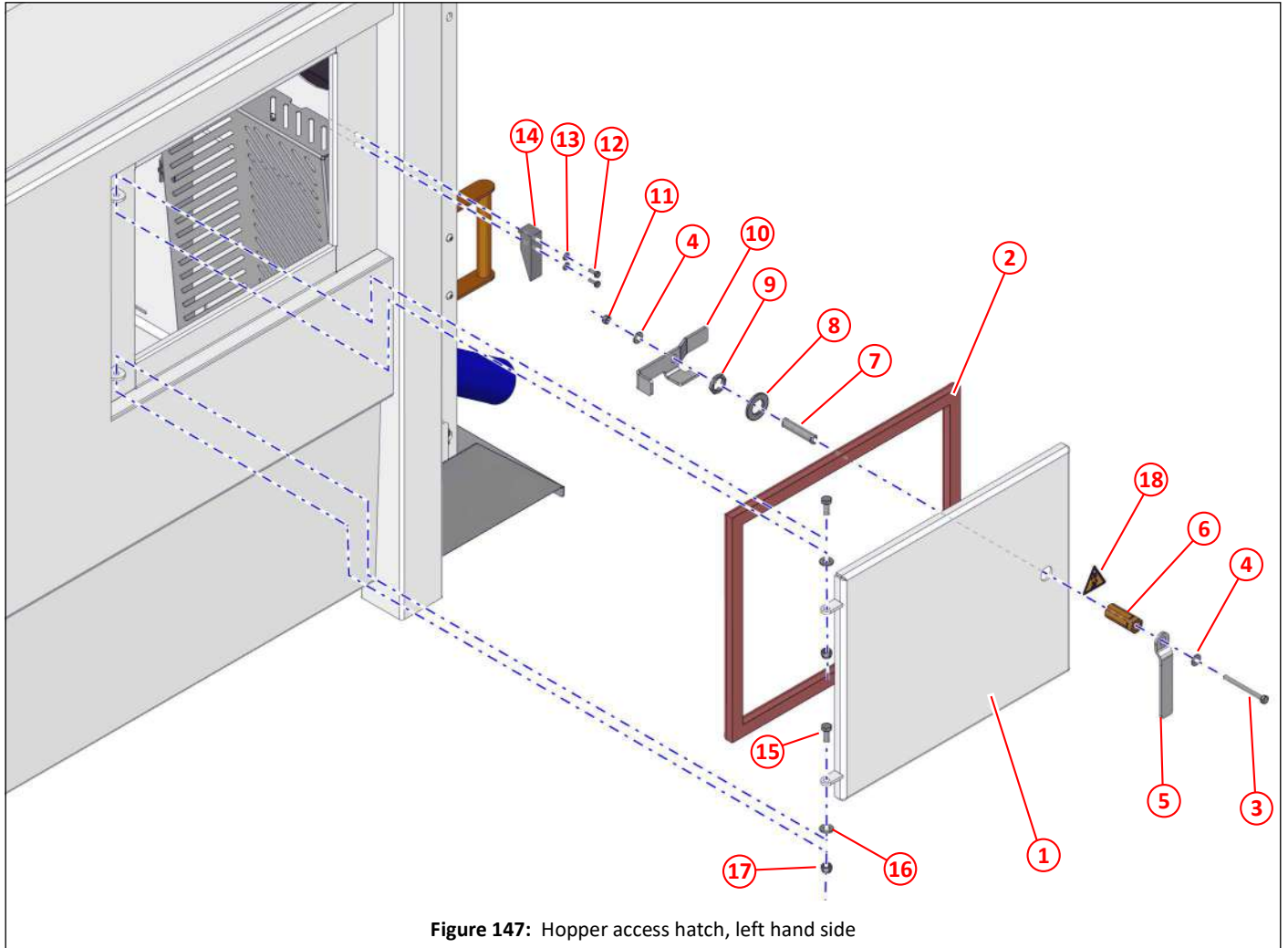

Figure 147: Hopper access hatch, left hand side

Item	Part No	Qty	Description
①	036363	1	Access hatch, hopper side
②	013599	1	Seal
③	011019	1	Bolt M8 x 90
④	011092	2	Washer M8
⑤	027933	1	Door handle
⑥	027935	1	Door catch bearing
⑦	027934	1	Door catch spindle
⑧	000121	1	Washer M27
⑨	027937	1	Backnut $\frac{3}{4}$ " BSP
⑩	040033	1	Door catch with stop, left hand
⑪	011073	1	Nyloc nut T M8
⑫	000250	2	Setscrew M6 x 16, stainless steel
⑬	000254	2	Washer M6, stainless steel
⑭	027932	1	Door striker
⑮	011031	2	Setscrew HT M10 x 25
⑯	011094	2	Washer M10
⑰	011075	2	Nyloc nut T M10
⑱	039550	1	Label - Warning debris falling

Hopper access hatch, right hand side

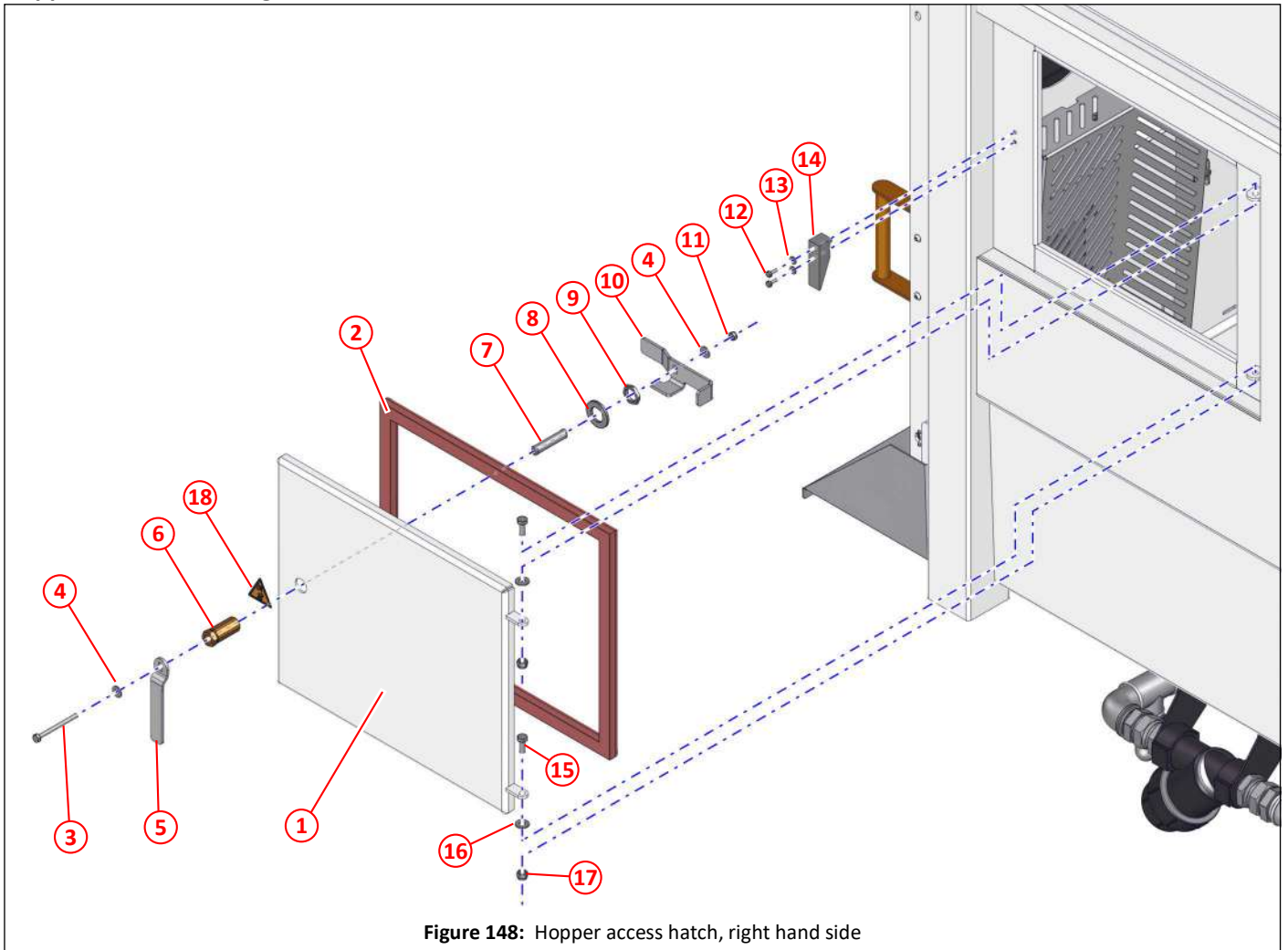

Figure 148: Hopper access hatch, right hand side

Item	Part No	Qty	Description
①	036363	1	Access hatch, hopper side
②	013599	1	Seal
③	011019	1	Bolt M8 x 90
④	011092	2	Washer M8
⑤	027933	1	Door handle
⑥	027935	1	Door catch bearing
⑦	027934	1	Door catch spindle
⑧	000121	1	Washer M27
⑨	027937	1	Backnut $\frac{3}{4}$ " BSP
⑩	040034	1	Door catch with stop, right hand
⑪	011073	1	Nyloc nut T M8
⑫	000250	2	Setscrew M6 x 16, stainless steel
⑬	000254	2	Washer M6, stainless steel
⑭	027932	1	Door striker
⑮	011031	2	Setscrew HT M10 x 25
⑯	011094	2	Washer M10
⑰	011075	2	Nyloc nut T M10
⑱	039550	1	Label - Warning debris falling

Hopper capping, left hand side

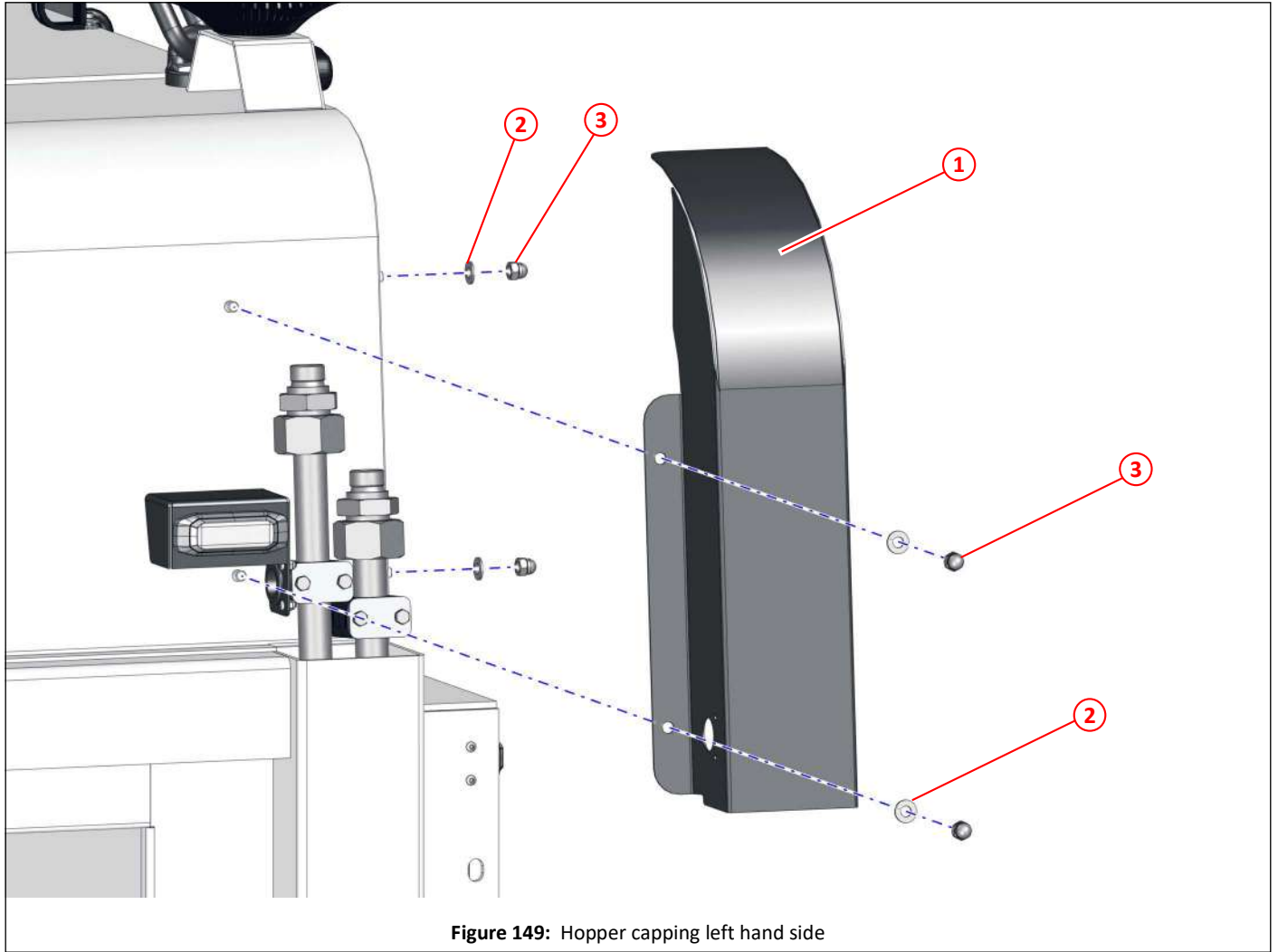

Figure 149: Hopper capping left hand side

Item	Part No	Qty	Description
①	047032	1	Hopper capping, left hand
②	000419	4	Washer M8 ø17
③	000089	4	Dome nut M8

Hopper capping, right hand side

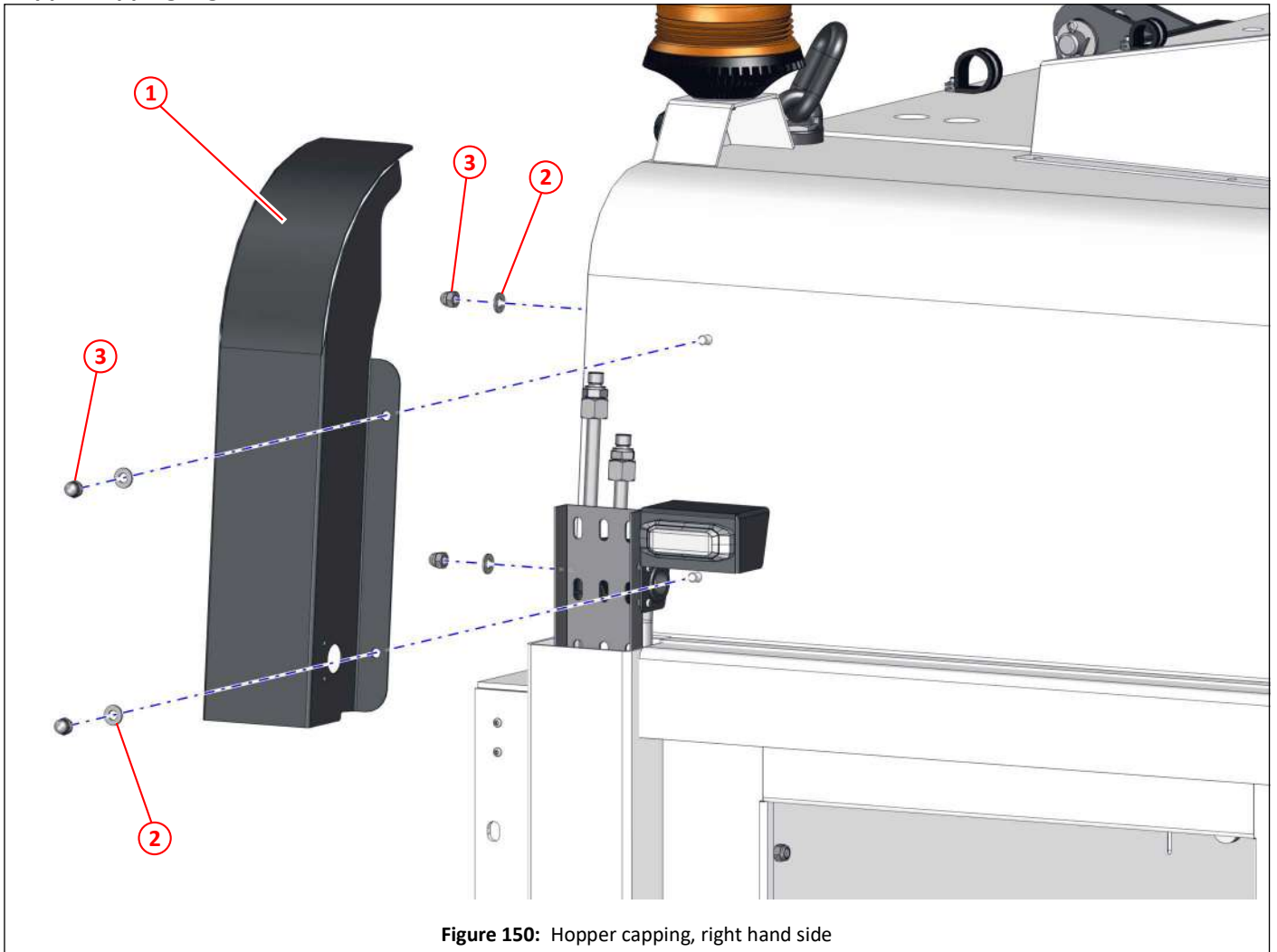

Figure 150: Hopper capping, right hand side

Item	Part No	Qty	Description
①	047033	1	Hopper capping, right hand
②	000419	4	Washer M8 ø17
③	000089	4	Dome nut M8

Hopper LED beacons and rear LED marker lights

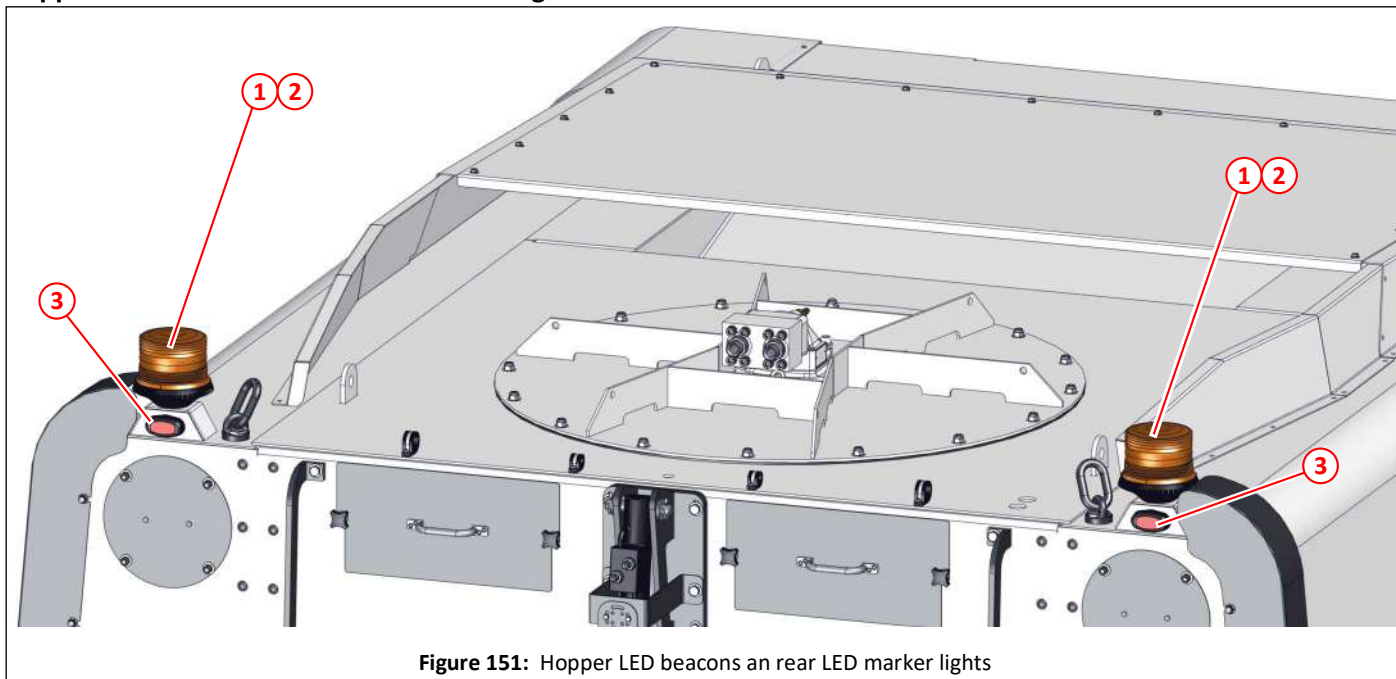

Figure 151: Hopper LED beacons an rear LED marker lights

Item	Part No	Qty	Description
①	046659	1	LED beacon, single bolt fixing, 10-30V
②	040727	1	Wiring loom for twin beacons
③	030773	2	LED marker light, 12V/24V

Hopper lifting eyes, bolts and plugs

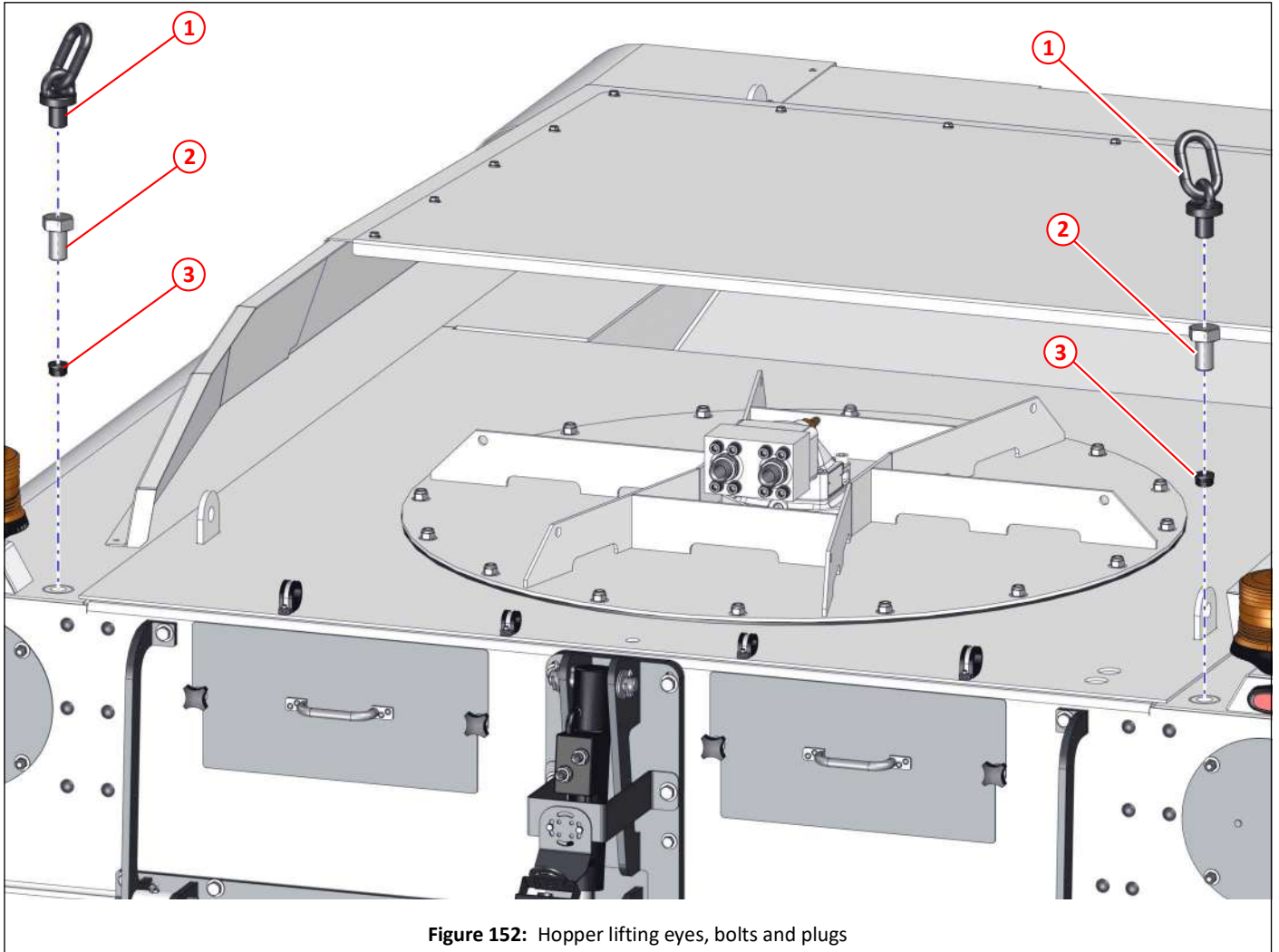

Figure 152: Hopper lifting eyes, bolts and plugs

Item	Part No	Qty	Description	
①	035941	2	Linked eye bolt M24, 1.6T	
②	000430	2	Screw M24 x 40, for attaching lifting equipment	
③	026173	2	Plastic plug	

Hose fixing clips, hopper

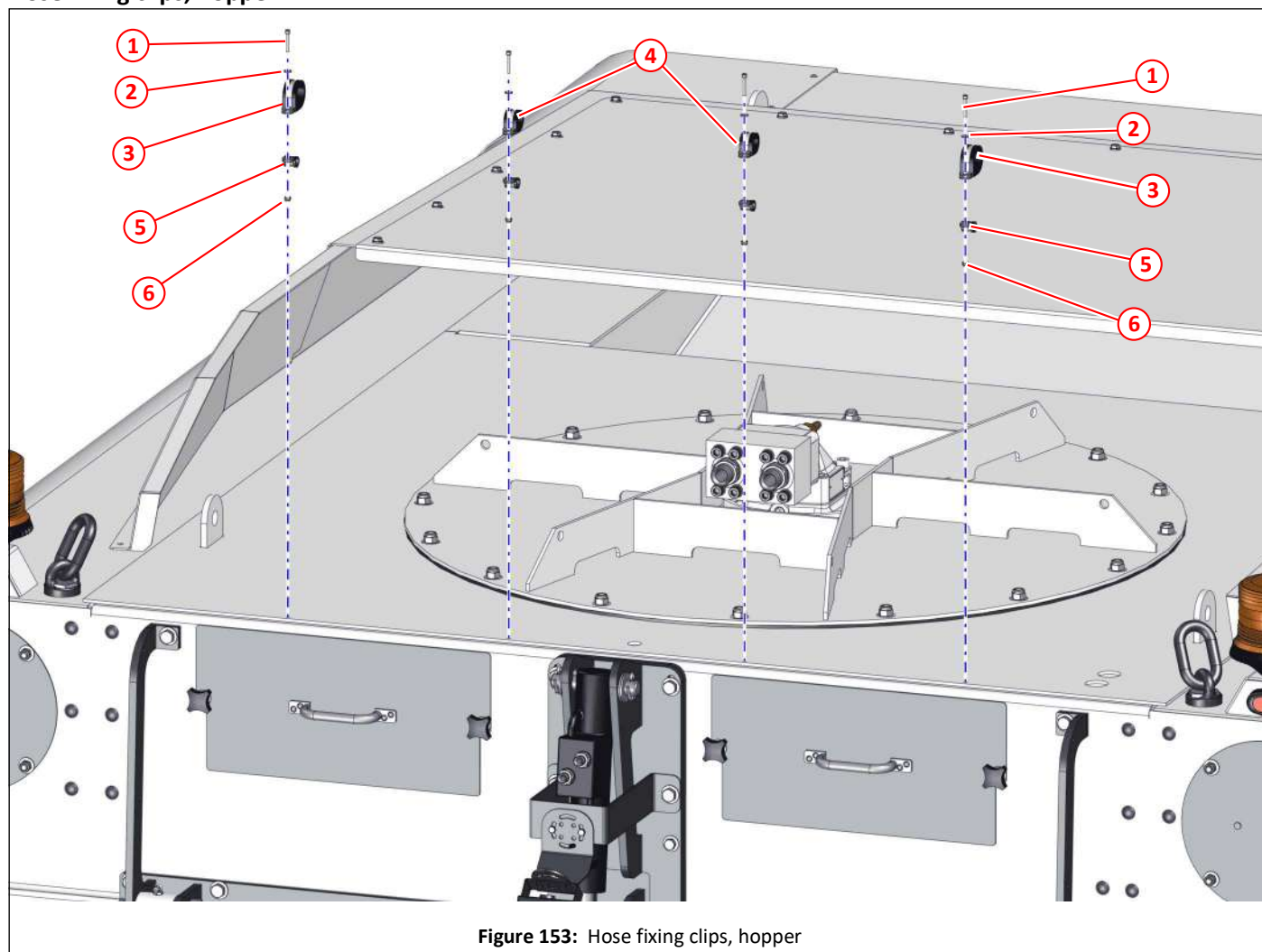
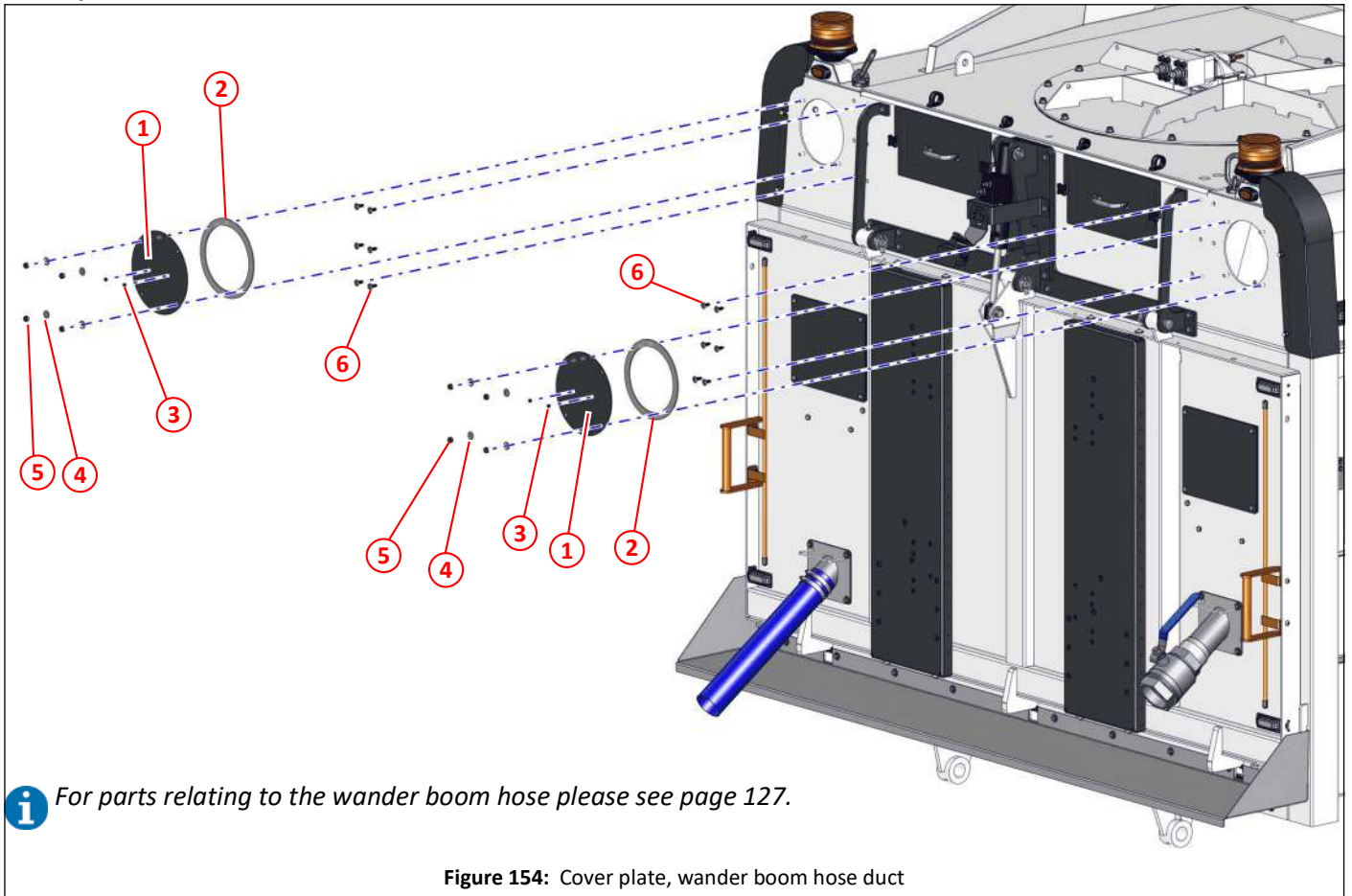

Figure 153: Hose fixing clips, hopper

Item	Part No	Qty	Description
①	000191	4	Socket cap head screw M4 x 25, plated
②	000410	4	Washer M5
③	024705	2	Clip ø35
④	005059	2	Clip ø22
⑤	021914 *	4	Clip ø12
⑥	000134 *	4	Nyloc nut T M4

*. These fittings are actually on the inside of the hopper, accessible via the fan access cover plates.

Cover plate, wander boom hose duct



Item	Part No	Qty	Description
①	025486 *	2	Cover plate, wander hose duct
②	013645	2	Inseal strip, cut length as required
③	044263	4	Blanking grommet ϕ 5
④	011092	8	Washer M8
⑤	011073	8	Nyloc nut T M8
⑥	014563 †	12	Fir tree button

*. Only 1 fitted if wander boom fitted.

†. Only fitted if no wander boom.

Fan inspection covers, external

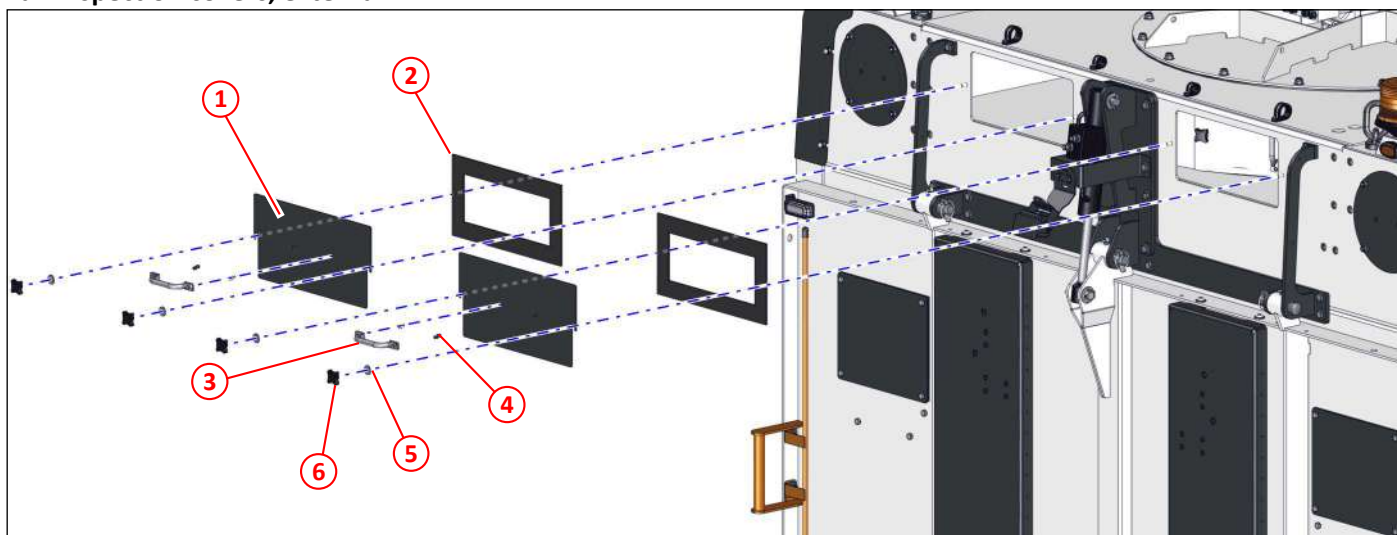

Figure 155: Fan inspection covers, external

Item	Part No	Qty	Description
①	030728	2	Cover plate, quick release, fan inspection, rear panel
②	010546	2	Inseal strip, cut length as required
③	010502	2	Pull handle
④	011124	8	Blind rivet $\varnothing 4.0 \times 10$
⑤	000264	4	Washer M8, stainless steel
⑥	000248	4	Grip nut M8

Fan inspection covers, internal

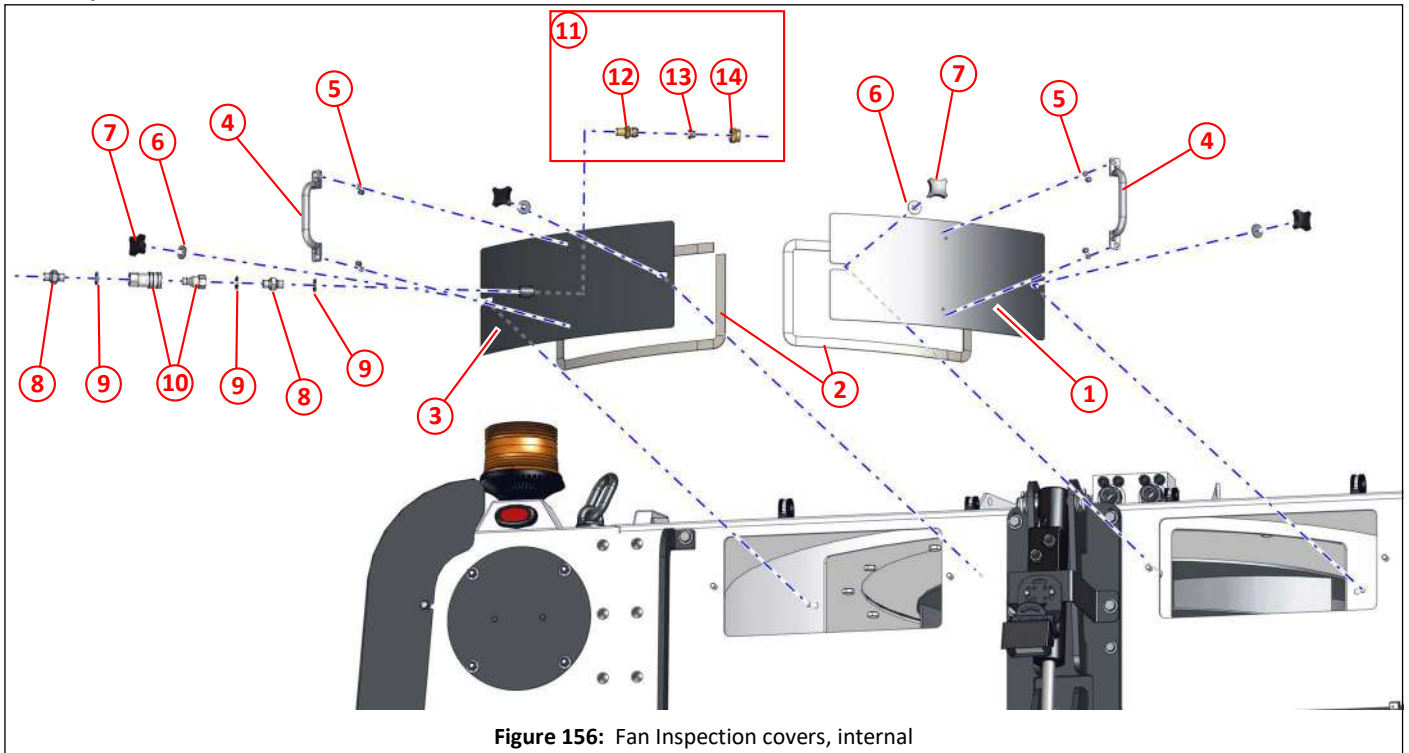

Figure 156: Fan Inspection covers, internal

Item	Part No	Qty	Description
①	030730 *	1	Cover plate, quick release, fan inspection, internal
②	005020	2	Sealing strip, expanding, 25 x 15, cut to required length
③	030731 †	1	Cover plate, quick release, fan wash assist
④	010502	2	Pull handle
⑤	011124	8	Blind rivet $\phi 4.0 \times 10$
⑥	000264	4	Washer M8, stainless steel
⑦	000248	4	Grip nut M8
⑧	011158	2	Adapter $\frac{1}{4}$ " BSP
⑨	011152	3	Dowty seal $\frac{1}{4}$ " BSP
⑩	012985	1	Quick release coupling, $\frac{1}{4}$ " BSP
⑪	030507	1	Spray jet assembly LF6-80, includes items d, f, and g
⑫	010112	1	Nozzle body
⑬	012926	1	Spray jet TPU-8006
⑭	030951	1	Nozzle cap

*. Two will be used if the fan wash assist is not fitted.

†. Only used when fan wash assist is fitted.

Hopper rear door arrangement

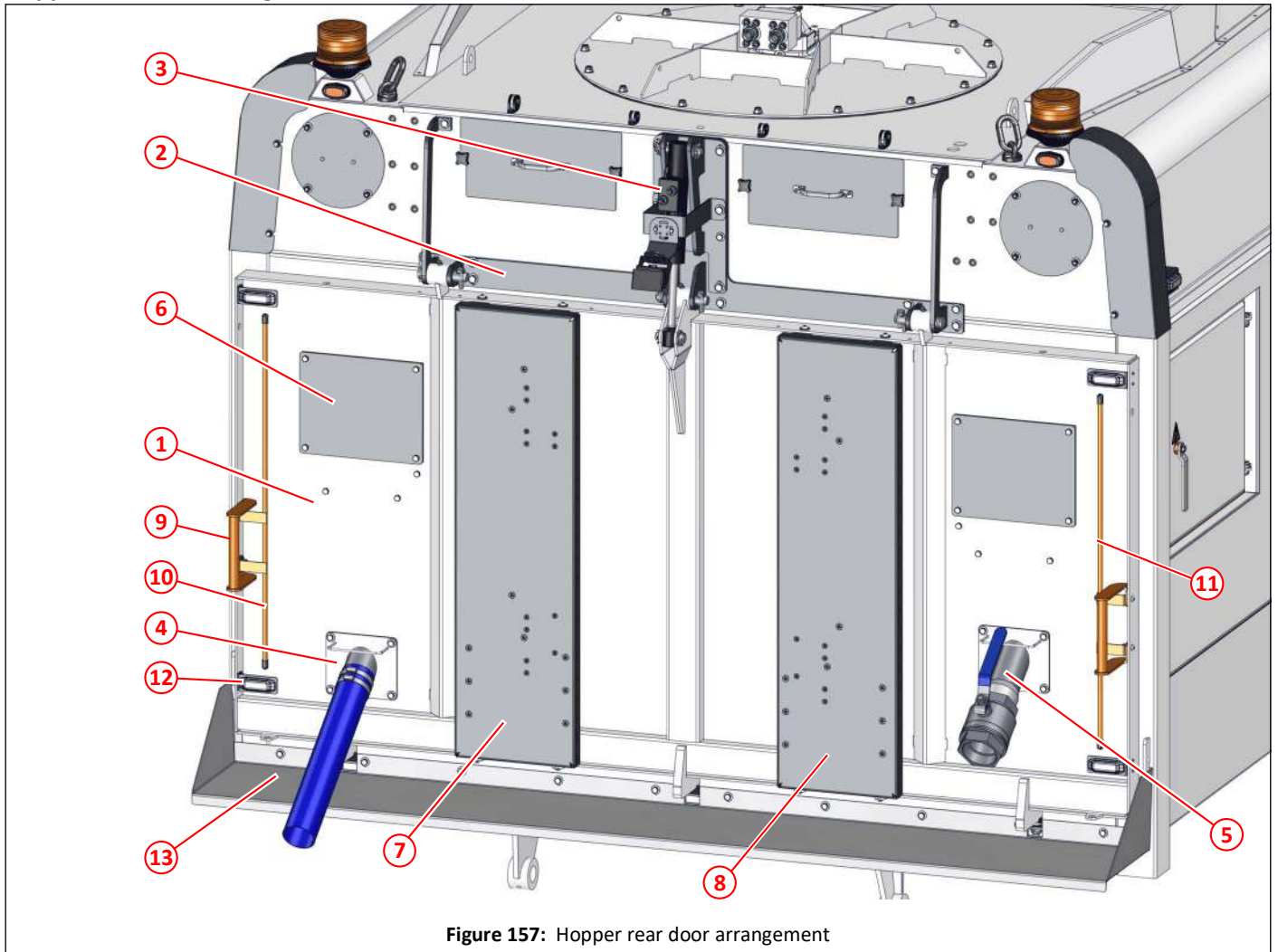

Figure 157: Hopper rear door arrangement

Item	Part No	Qty	Description	
①	046850	1	Rear door	185
②	024345	1	Hinge plate, rear door	200
③	022511	1	Ram, open/close, rear door	200
④	047026	1	Rear strainer outlet	191
⑤	047141	1	Rear strainer outlet, with valve	192
⑥	047261	2	Wander hose blanking plate	185
⑦	046982	1	Rear door options bracket, left hand	185
⑧	046983	1	Rear door options bracket, right hand	185
⑨	039593	2	Grab handle	187
⑩	048241	1	Cable guide, rear door light, left hand	187
⑪	048240	1	Cable guide, rear door light, right hand	187
⑫	047979	4	LED warning light	188
⑬	046845	1	Hopper chute	202

Hopper rear door

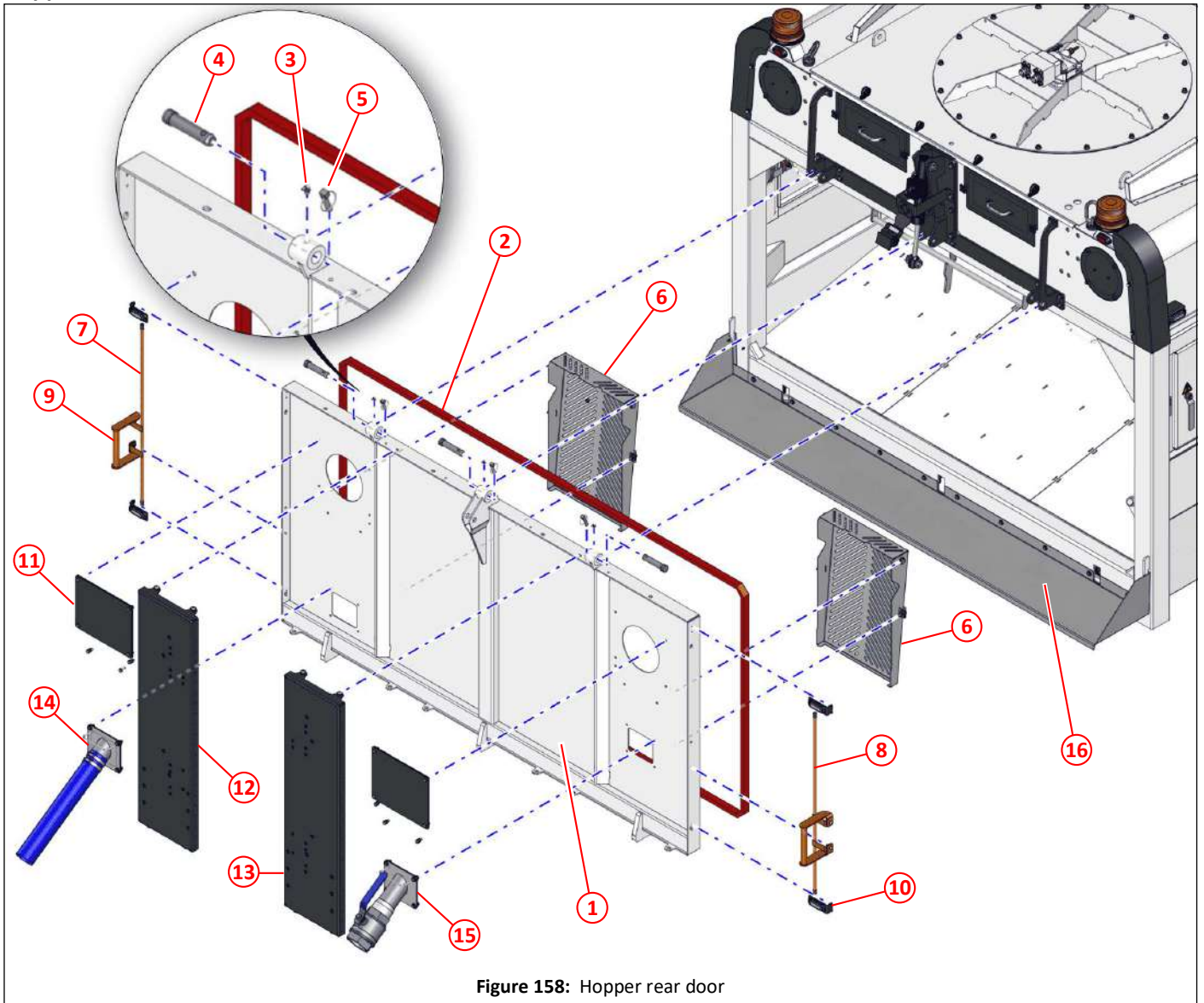

Figure 158: Hopper rear door

Item	Part No	Qty	Description	
①	046850	1	Rear door	
②	030806	1	Seal, circular section, rear door, 6.8m	
③	010902	3	Grease nipple $\frac{1}{8}$ " BSP, 90°	
④	013051	3	Hinge pin	
⑤	013053	3	Lynch pin	
⑥	047994	2	Strainer assembly, tall, rear door	186
⑦	048241	1	Cable guide, rear door light, left hand	
⑧	048240	1	Cable guide, rear door light, right hand	
⑨	039593	2	Grab handle	
⑩	047979	4	LED warning light, actual quantity as per machine	188
⑪	047261 *	2	Wander hose blanking plate	
⑫	046982	1	Rear door options bracket, left hand	
⑬	046983	1	Rear door options bracket, right hand	
⑭	047026	1	Rear door strainer outlet	
⑮	047141	1	Rear door strainer outlet for valve	
⑯	046845	1	Hopper chute	
NI	047117	1	Rear door assembly, includes items ①, ②, and ③	

*. Two required unless wander hose installed on rear door then only one required.

Strainer, tall, rear door

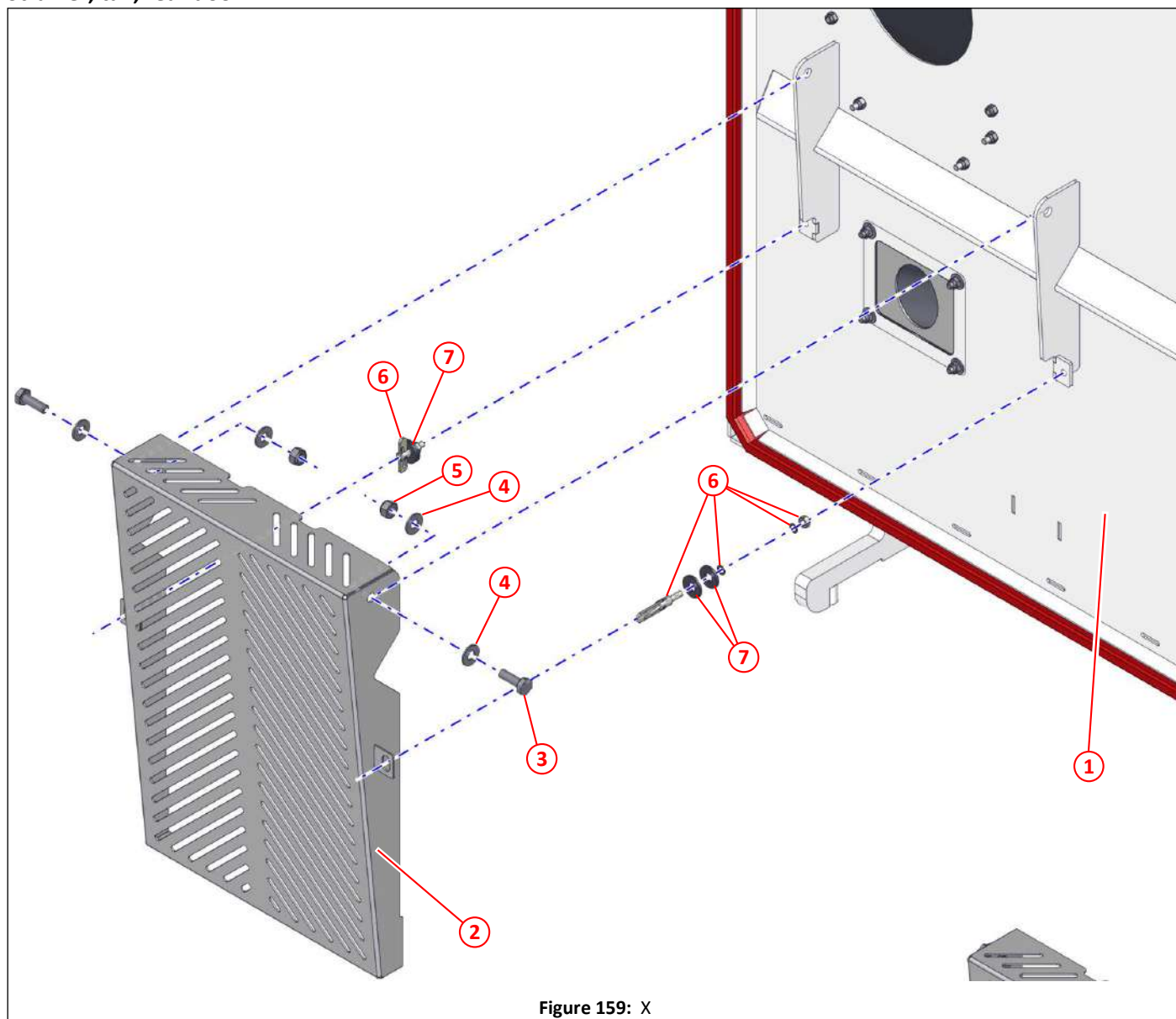

Figure 159: X

Item	Part No	Qty	Description
①	047117	1	Rear door assembly
②	047993 *	1	Strainer, tall, rear door
③	000285 *	2	Setscrew M23 x 35, stainless steel
④	000277 *	4	Washer M12, stainless steel
⑤	000275 *	2	Nyloc nut T M12, stainless steel
⑥	012253 *	2	Antiluce, small
⑦	021979 *	4	Rubber sealing washer $\varnothing 30 \times \varnothing 12 \times 3$
NI	047994 *	1	Strainer assembly, tall, rear door, includes all items except ①

*. Two required per rear door.

Grab handles and cable guides, rear door

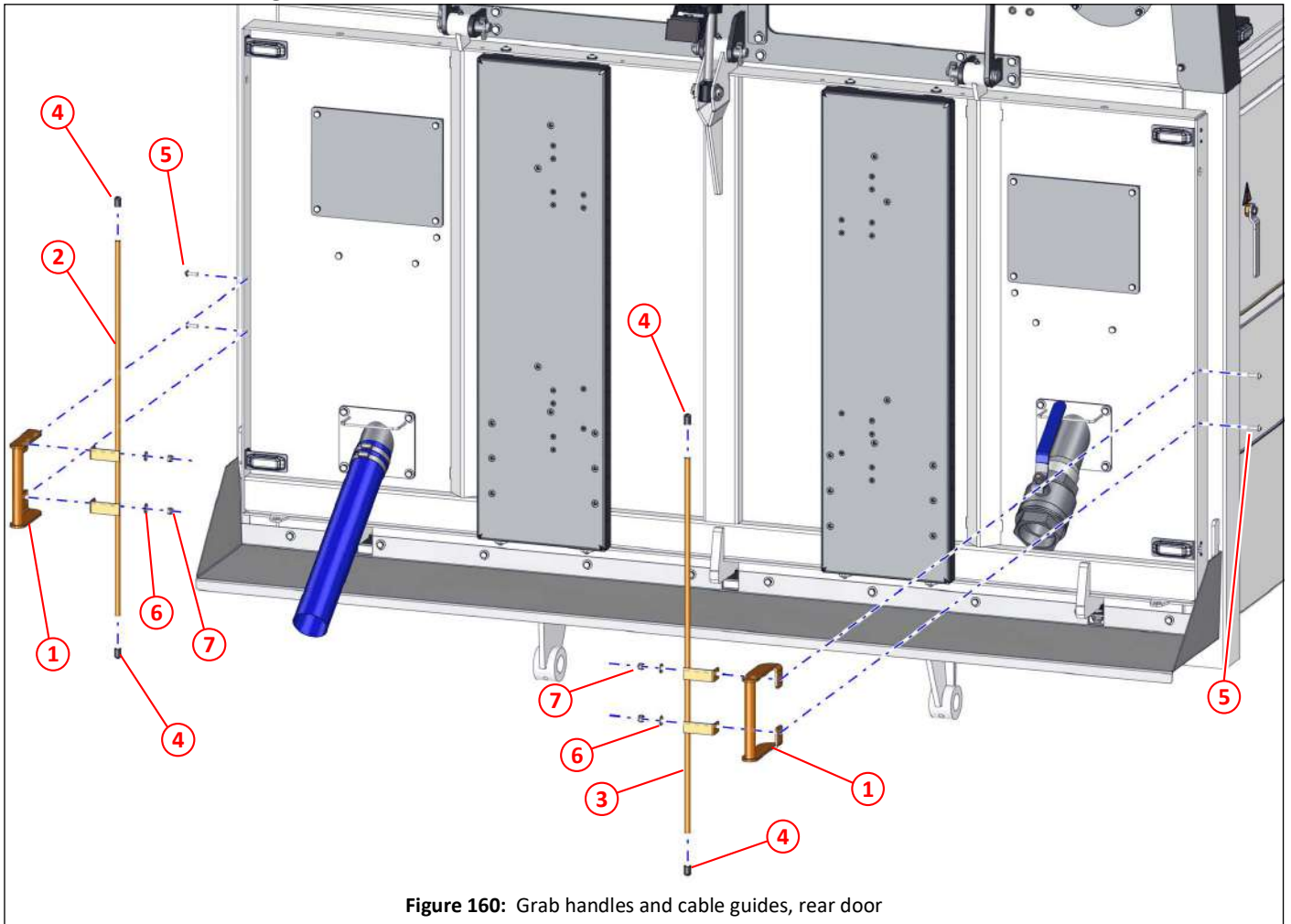

Figure 160: Grab handles and cable guides, rear door

Item	Part No	Qty	Description
①	039593	2	Grab handle
②	048241	1	Cable guide, rear door light, left hand
③	048240	1	Cable guide, rear door light, right hand
④	043065	4	Pipe cap \varnothing 12
⑤	000281	4	Socket button head screw M8 x 25, stainless steel
⑥	000264	4	Washer M8, stainless steel
⑦	000263	4	Nyloc nut T M8, stainless steel

Warning lights, rear door

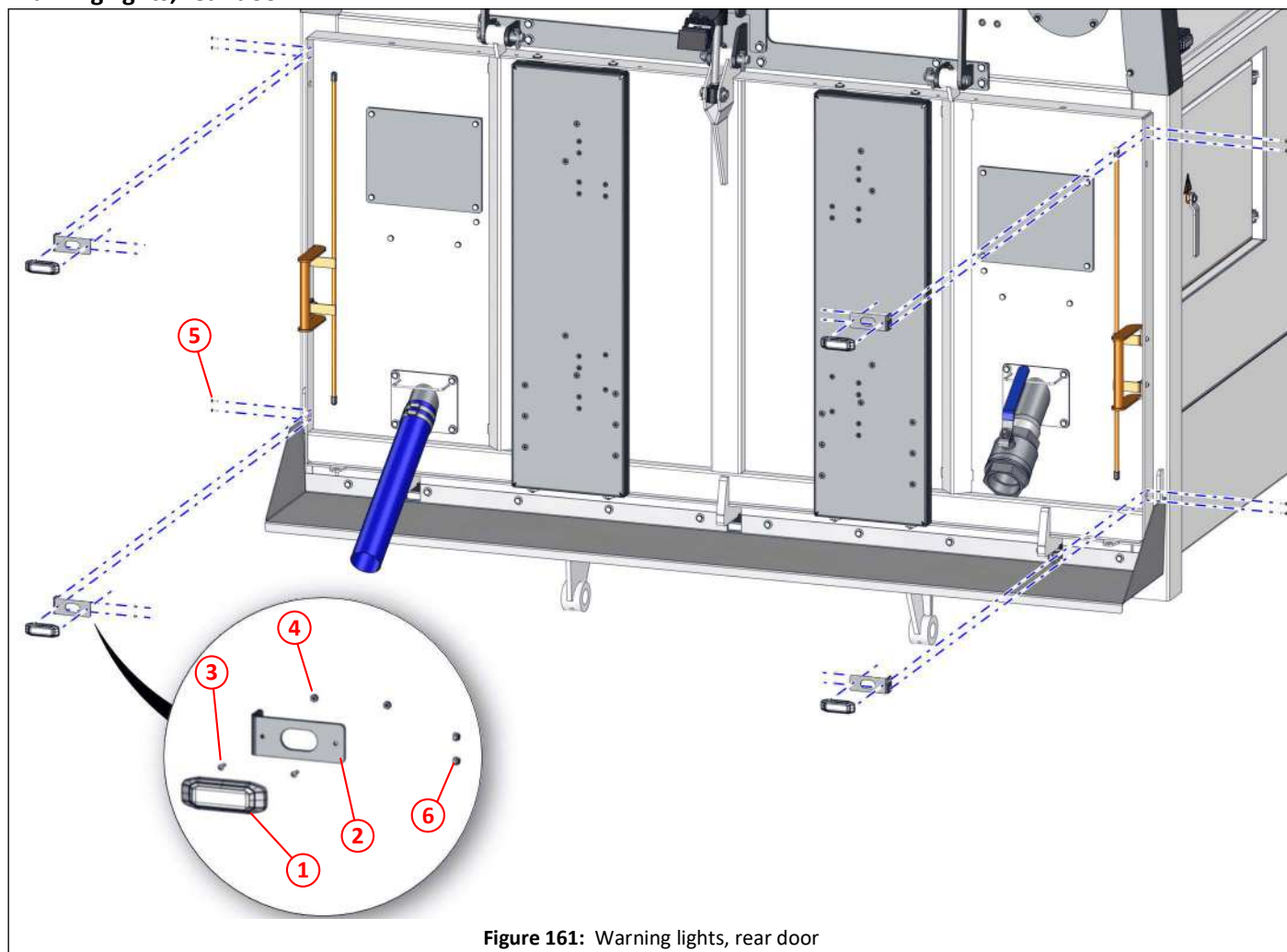

Figure 161: Warning lights, rear door

Item	Part No	Qty	Description
①	047979 *	1	LED warning light assembly
②	048239 *	1	Light bracket, rear
③	000540 *	2	Socket button head screw M3 x 10, stainless steel
④	000359 *	2	Nyloc nut M3, stainless steel
⑤	000542 *	2	Socket button head screw M4 x 16, stainless steel
⑥	000541 *	2	Nyloc nut M4, stainless steel

*. Quantity is per light. Number of lights fitted depends on specification of the sweeper.

Warning light, hopper rear right side

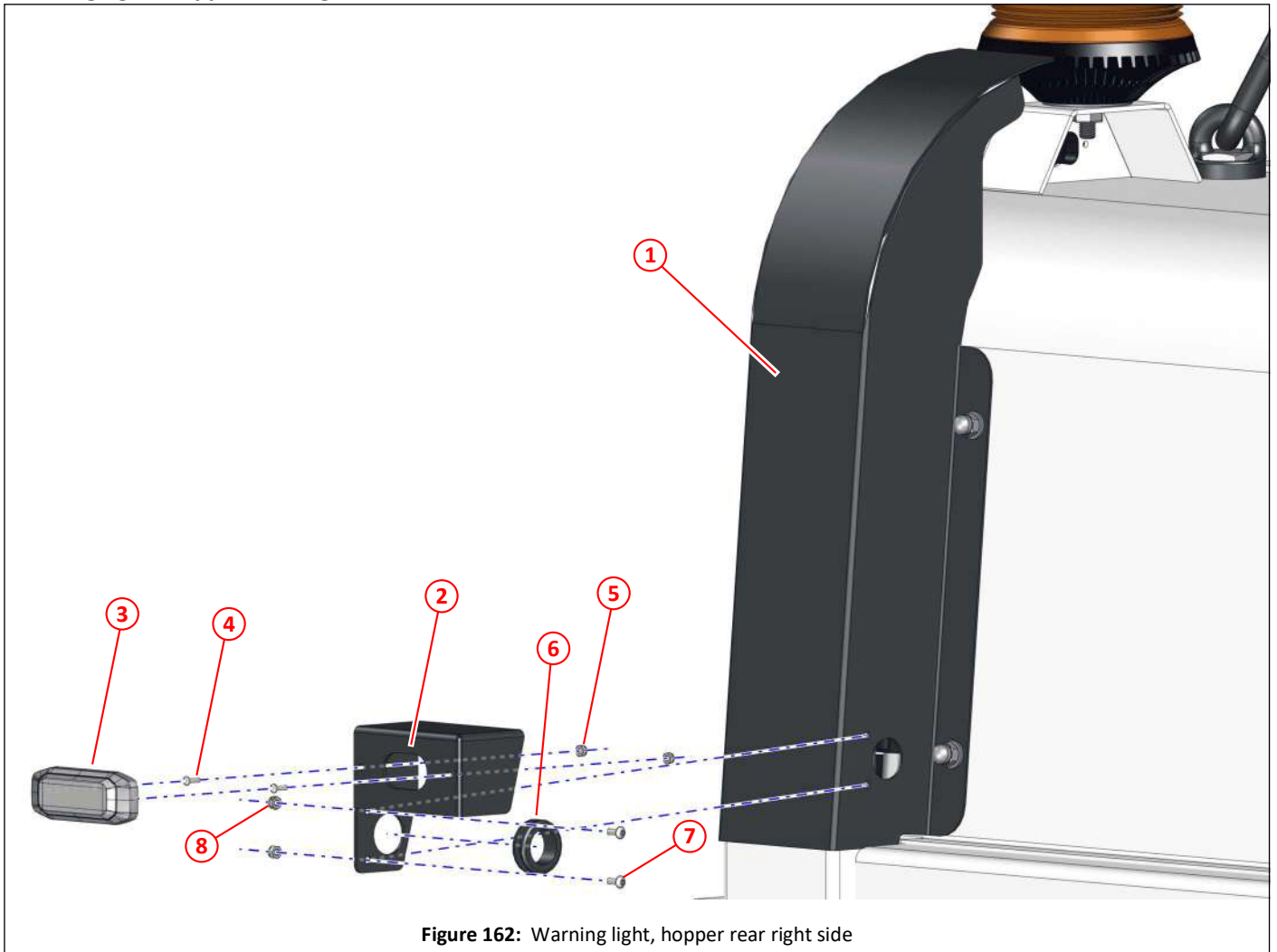

Figure 162: Warning light, hopper rear right side

Item	Part No	Qty	Description
①	047033	1	Hopper capping, right hand
②	048244	1	Light bracket (side), right hand
③	047979	1	LED warning light assembly
④	000540	2	Socket button head screw M3 x 10, stainless steel
⑤	000359	2	Nyloc nut M3, stainless steel
⑥	048204	1	Grommet $\phi 25.4 \times \phi 22$
⑦	000543	2	Socket button head screw M4 x 10, stainless steel
⑧	000541	2	Nyloc nut M4, stainless steel

Warning light, hopper rear left side

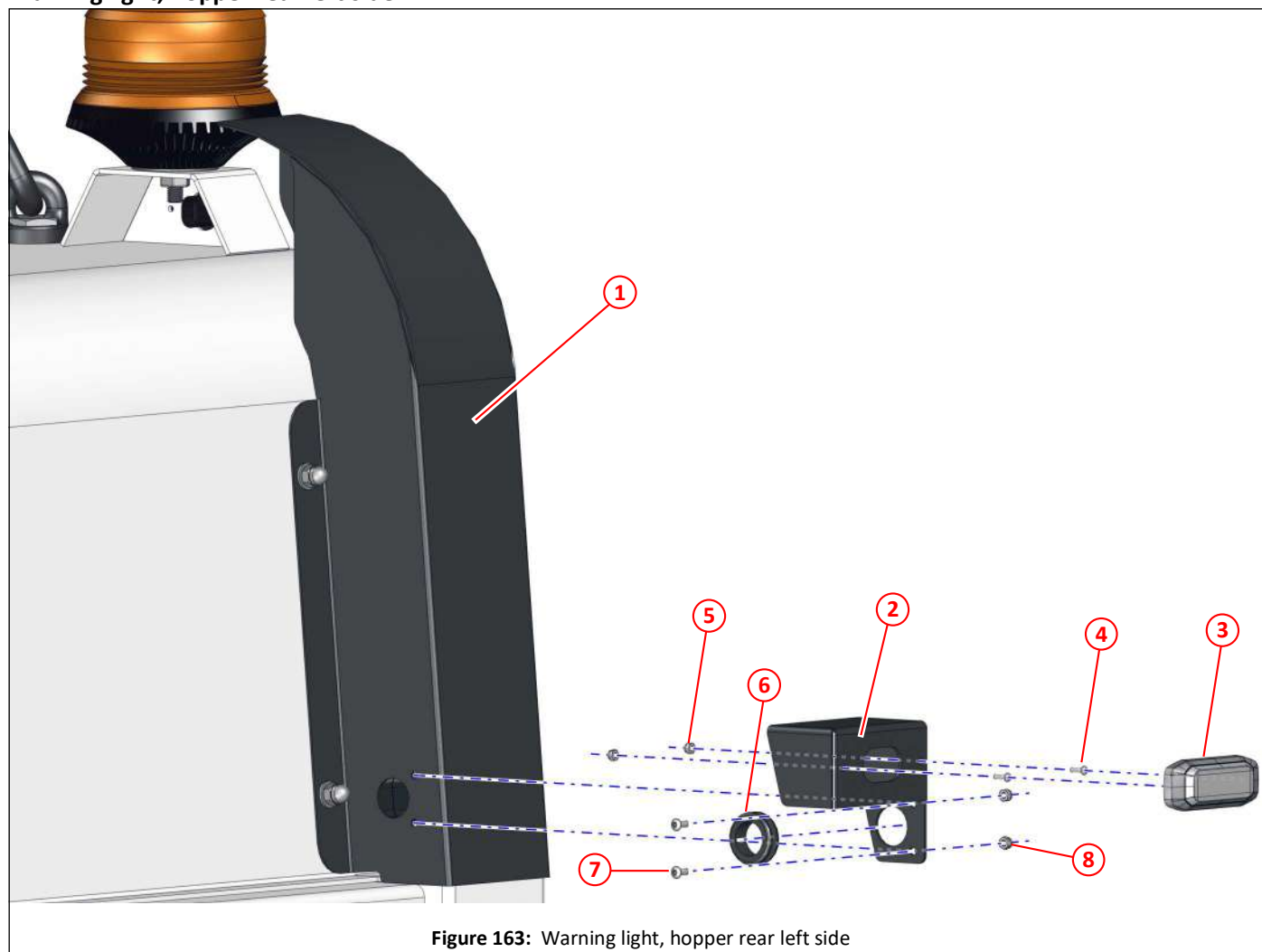

Figure 163: Warning light, hopper rear left side

Item	Part No	Qty	Description
①	047032	1	Hopper capping, left hand
②	048245	1	Light bracket (side), left hand
③	047979	1	LED warning light assembly
④	000540	2	Socket button head screw M3 x 10, stainless steel
⑤	000359	2	Nyloc nut M3, stainless steel
⑥	048204	1	Grommet $\phi 25.4 \times \phi 22$
⑦	000543	2	Socket button head screw M4 x 10, stainless steel
⑧	000541	2	Nyloc nut M4, stainless steel

Rear door strainer outlet, hose version

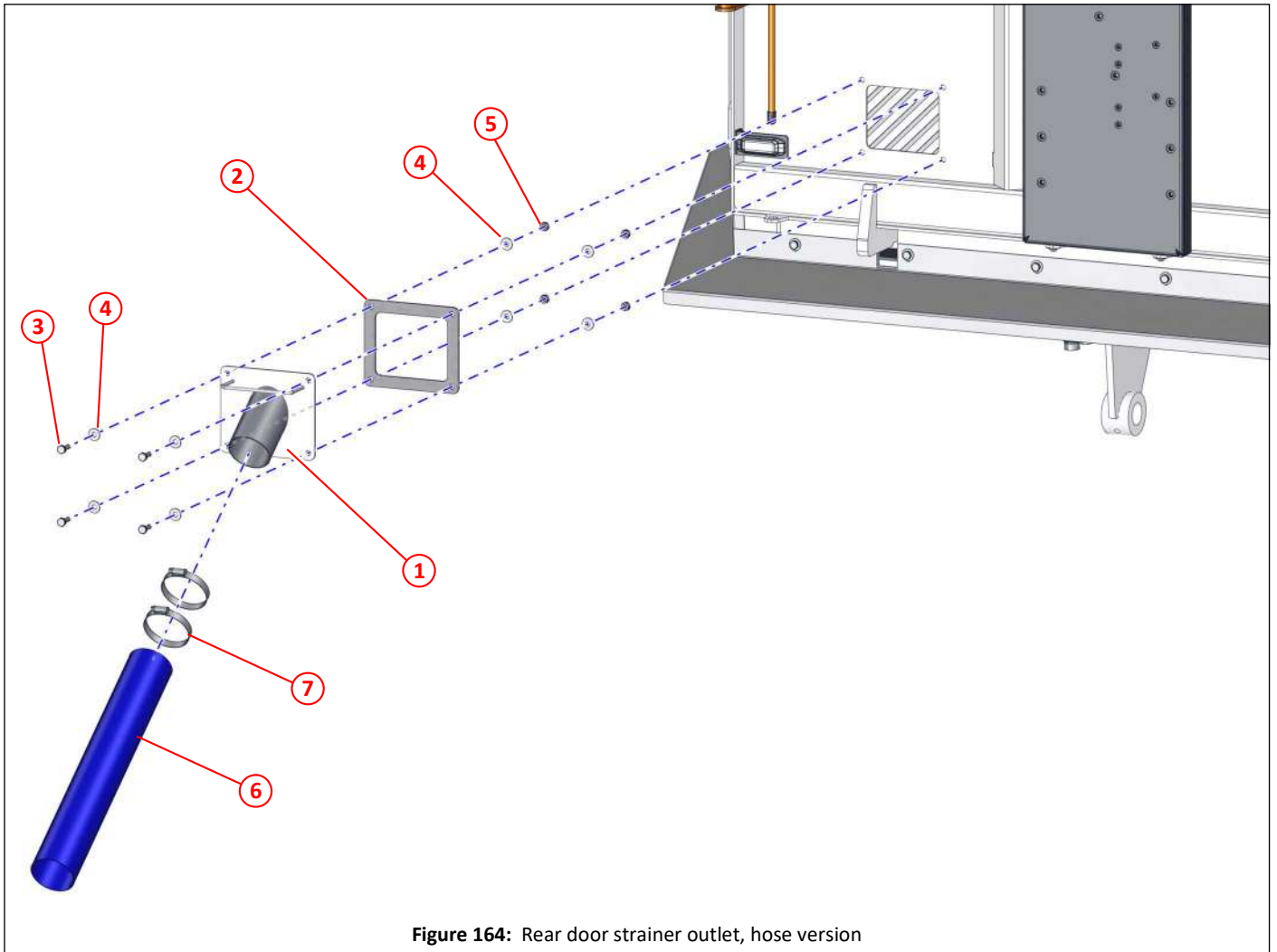

Figure 164: Rear door strainer outlet, hose version

Item	Part No	Qty	Description
①	047026	1	Rear door strainer outlet
②	047027	1	Gasket, rear door strainer outlet
③	000257	4	Setscrew M8 x 25, stainless steel
④	000264	8	Washer M8, stainless steel
⑤	000263	4	Nyloc nut T M8, stainless steel
⑥	010998	1	Hose, lay-flat blue
⑦	012931	2	Jubilee clip No 4 [ø70 - ø90]

Rear door strainer outlet, valve version

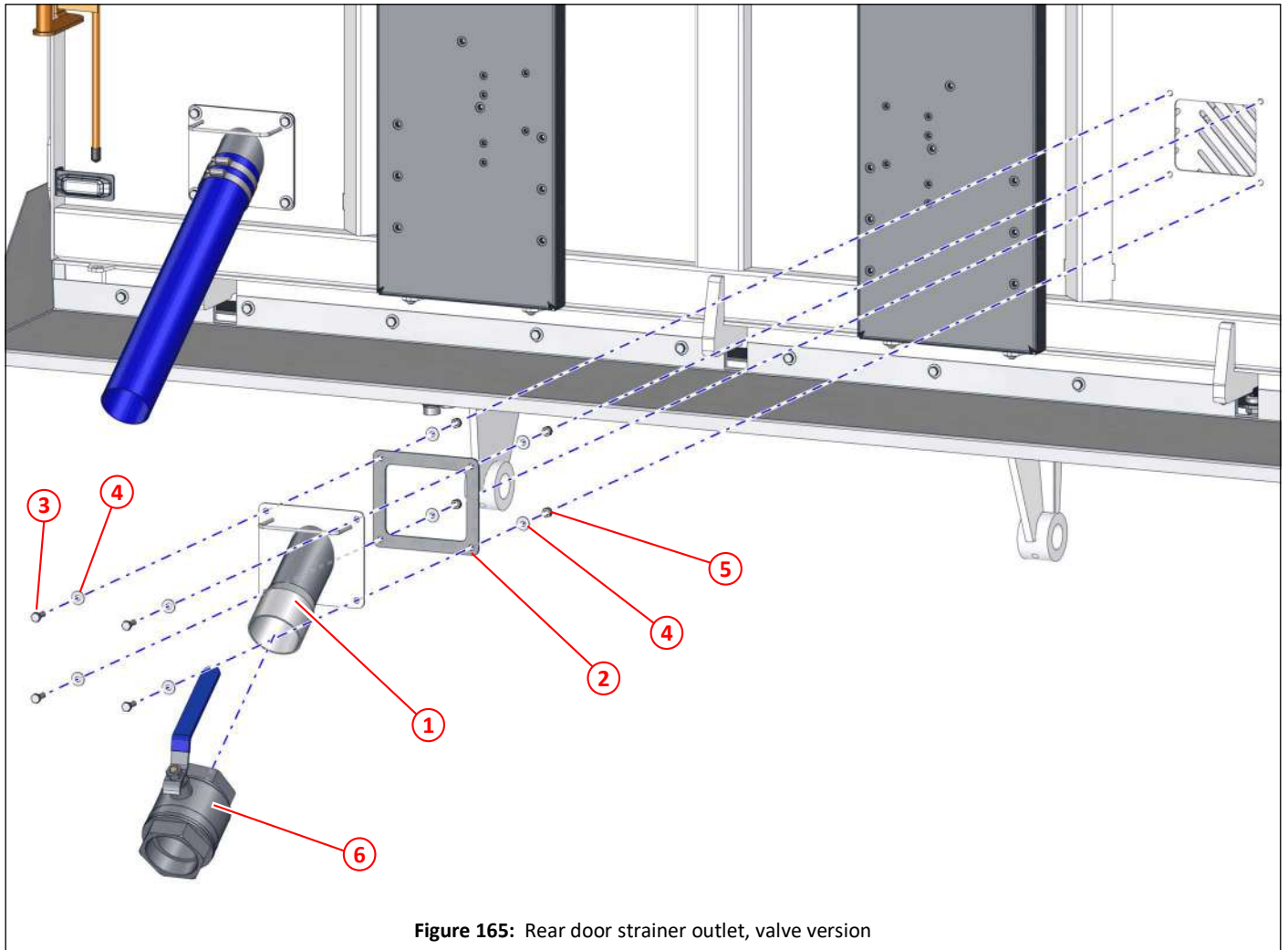
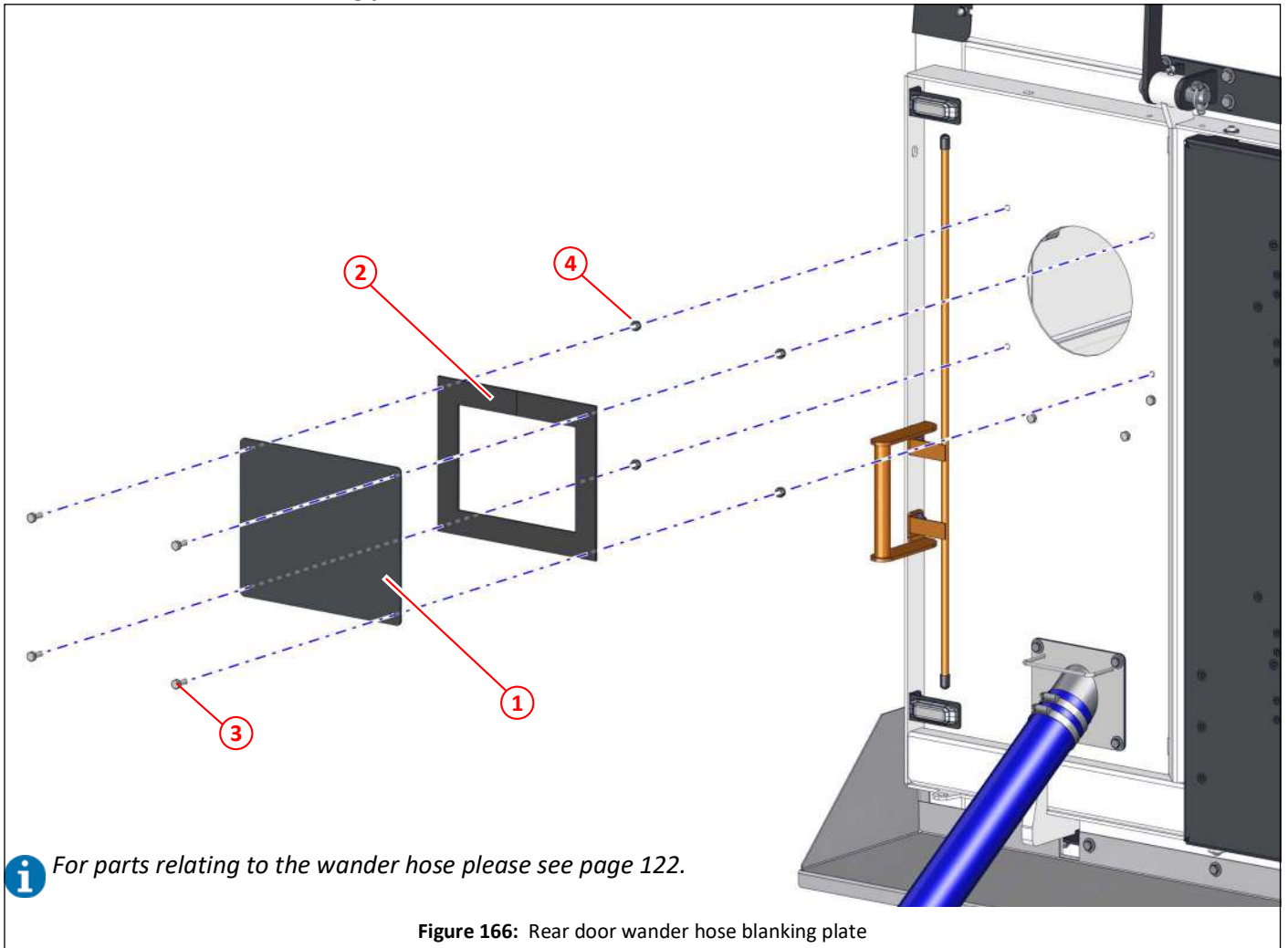

Figure 165: Rear door strainer outlet, valve version

Item	Part No	Qty	Description
①	047141	1	Rear door strainer outlet for valve
②	047027	1	Gasket, rear door strainer outlet
③	000257	4	Setscrew M8 x 25, stainless steel
④	000264	8	Washer M8, stainless steel
⑤	000263	4	Nyloc nut T M8, stainless steel
⑥	002116	1	Valve, ball, 3" BSP, comes with handle

Rear door wander hose blanking plate



Item	Part No	Qty	Description
①	047261 *	1	Blanking plate, wander hose
②	010546	1	Inseal strip, cut length as required
③	000256	4	Setscrew M8 x 20, stainless steel
④	000263	4	Nyloc nut T M8, stainless steel

*. Two will be fitted if no wander hose or wander boom fitted.

Rear door options brackets

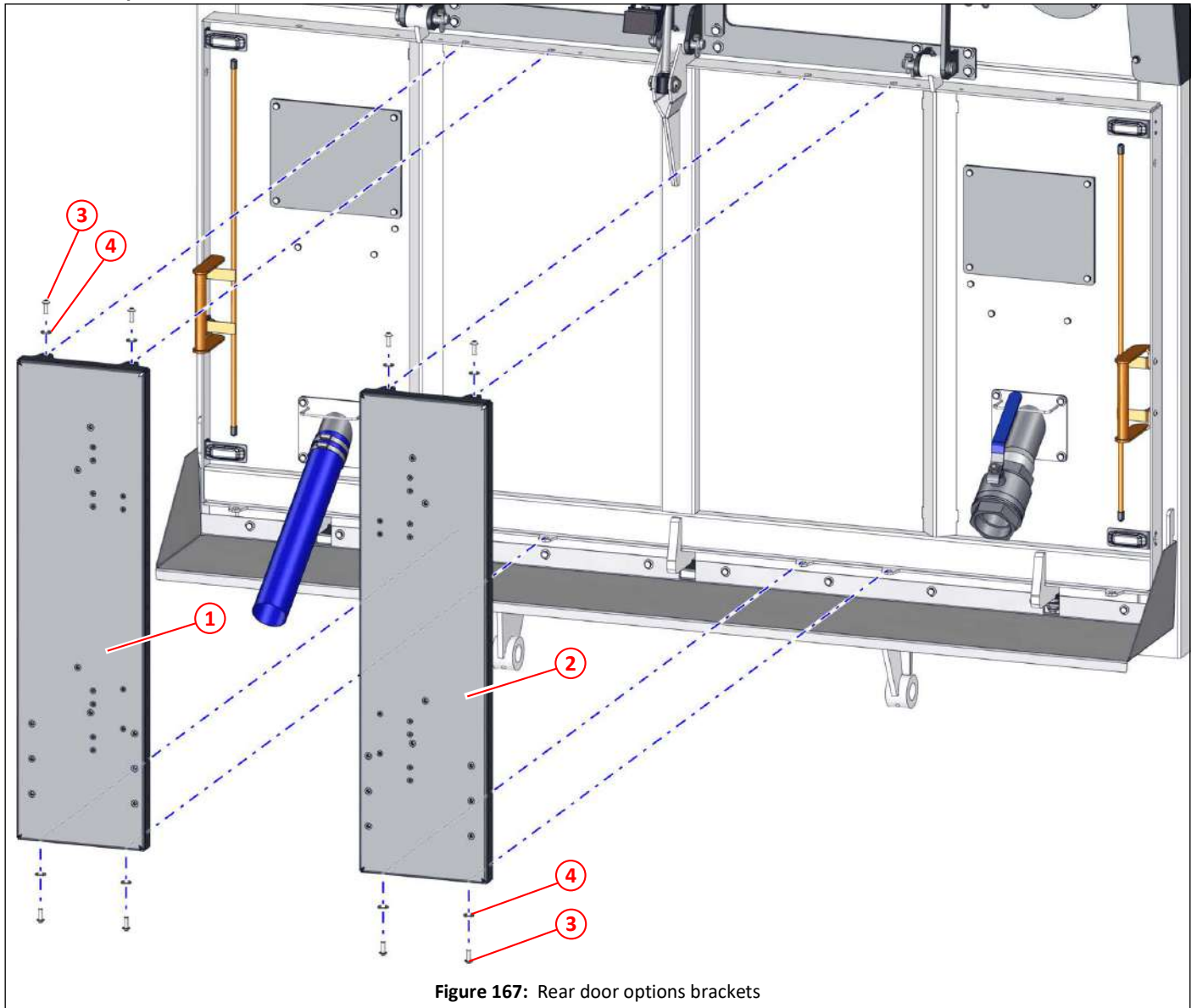

Figure 167: Rear door options brackets

Item	Part No	Qty	Description
①	046982	1	Rear door options bracket, left hand
②	046983	1	Rear door options bracket, right hand
③	000344	8	Socket button head screw M10 x 25, stainless steel
④	000270	8	Washer M10, stainless steel

Wander hose storage hooks - Rear door option

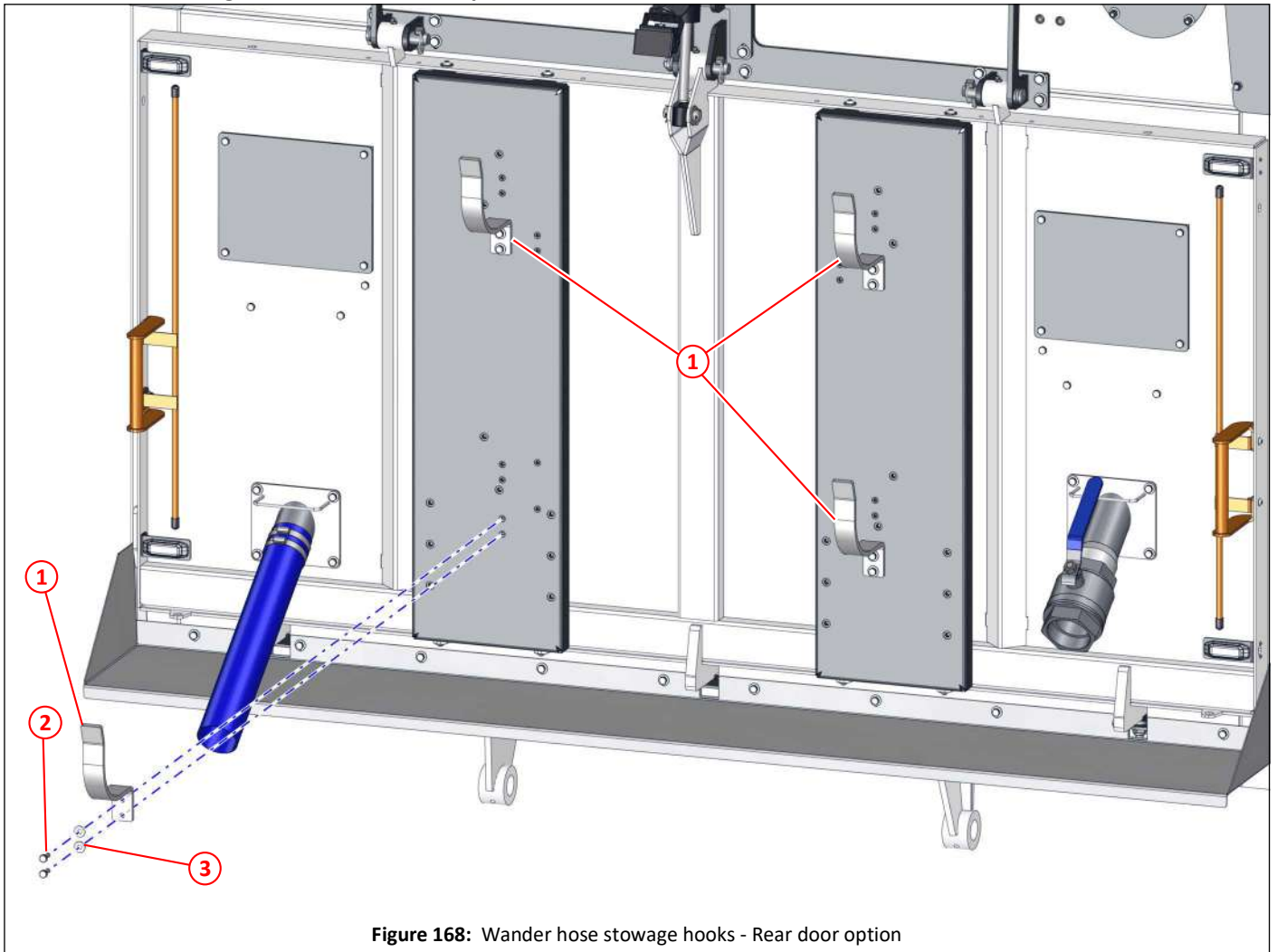

Figure 168: Wander hose storage hooks - Rear door option

Item	Part No	Qty	Description	
①	010245	4	Hose hook, wander hose	
②	000257	8	Setscrew M8 x 25, stainless steel	
③	000264	8	Washer M8, stainless steel	

Direction arrow, when no hose hooks - Rear door option

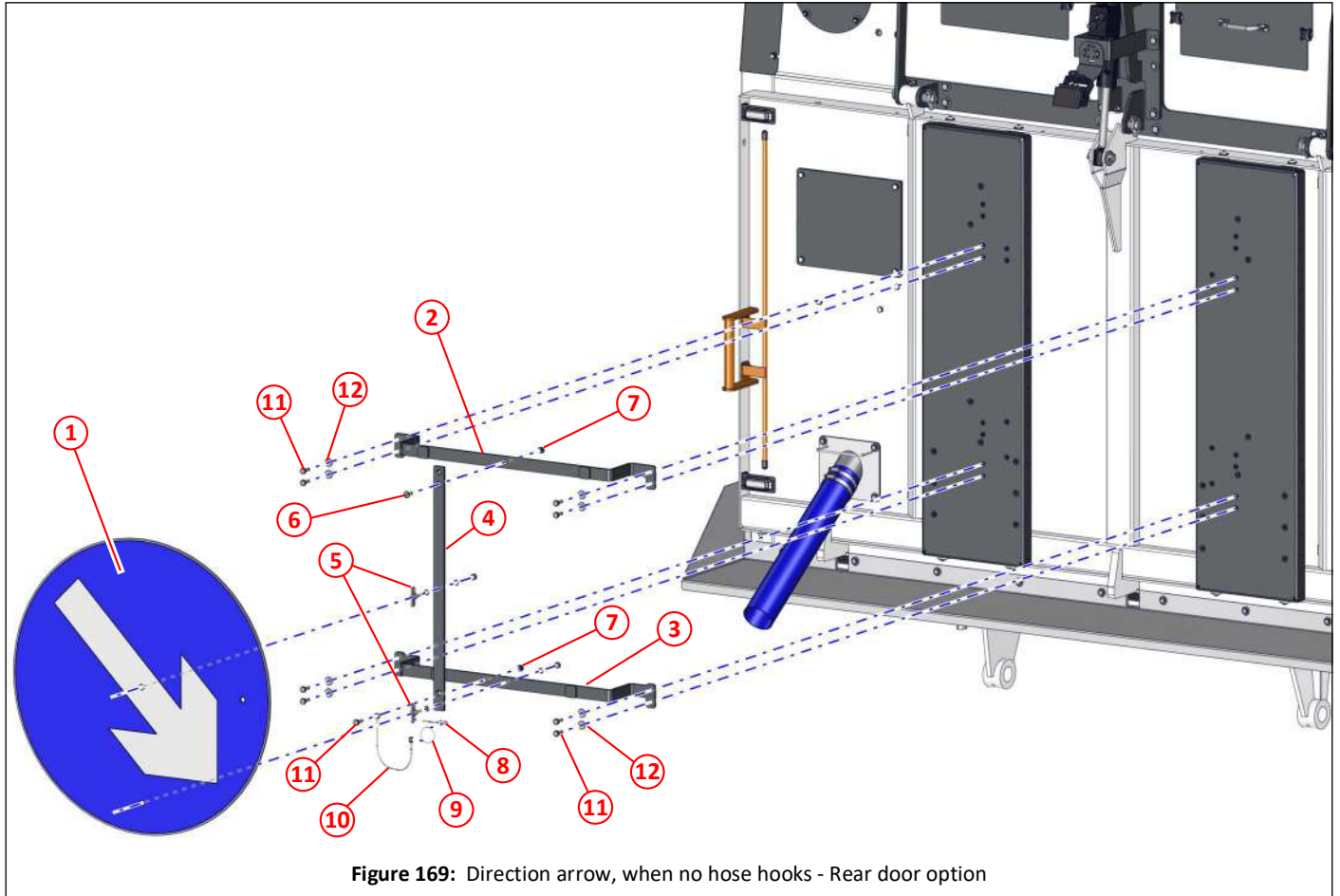

Figure 169: Direction arrow, when no hose hooks - Rear door option

Item	Part No	Qty	Description
①	021869	1	Direction sign \varnothing 750
②	035818	1	Rear sign upper support, no hose hooks
③	035819	1	Rear sign lower support, no hose hooks
④	031978	1	Rear sign centre support
⑤	012253	2	Antiluce, small, includes washer and nut
⑥	000109	1	Countersunk slotted screw M8 x 25
⑦	011073	2	Nyloc nut T M8
⑧	021944	1	R-clip, double wound, \varnothing 3 wire
⑨	023599	1	Ring pull
⑩	020711	1	Leash cable
⑪	000257	9	Setscrew M8 x 25, stainless steel
⑫	000264	8	Washer M8, stainless steel

Direction arrow, when hose hooks are used - Rear door option

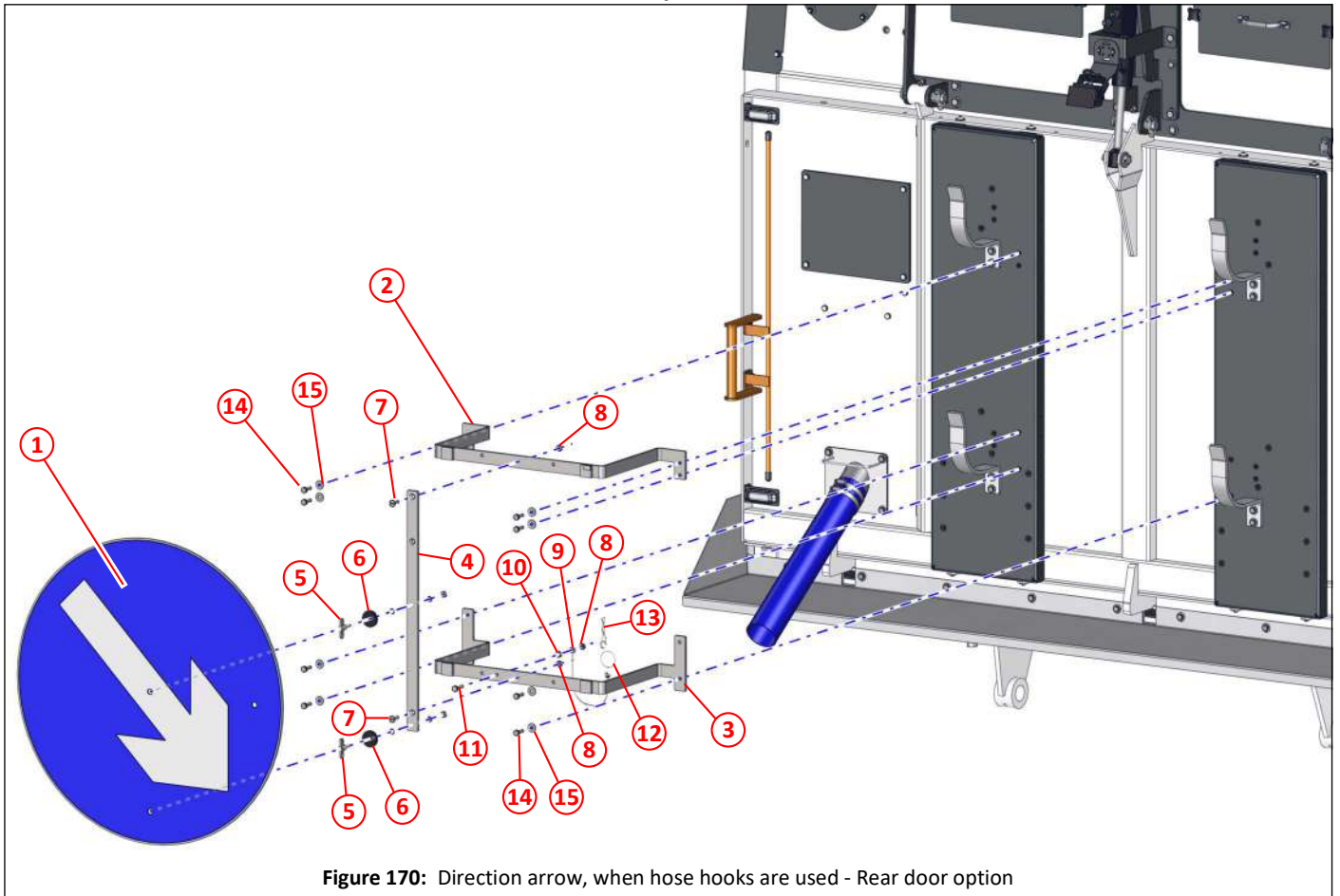

Figure 170: Direction arrow, when hose hooks are used - Rear door option

Item	Part No	Qty	Description
①	021869	1	Direction sign ø750
②	031976	1	Rear sign upper support
③	031977	1	Rear sign lower support
④	031982	1	Rear sign centre support
⑤	012253	2	Antiluce, small, includes washer and nut
⑥	012969	2	Rubber washer ø40 x ø12 x 6
⑦	000109	2	Countersunk slotted screw M8 x 25
⑧	011073	3	Nyloc nut T M8
⑨	020711	1	Leash cable
⑩	011072	1	Full nut M8
⑪	011012	1	Setscrew HT M8 x 30
⑫	023599	1	Ring pull
⑬	021944	1	R-clip, double wound, ø3 wire
⑭	000257	8	Setscrew M8 x 25, stainless steel
⑮	000264	8	Washer M8, stainless steel

Light Arrow - Rear door option

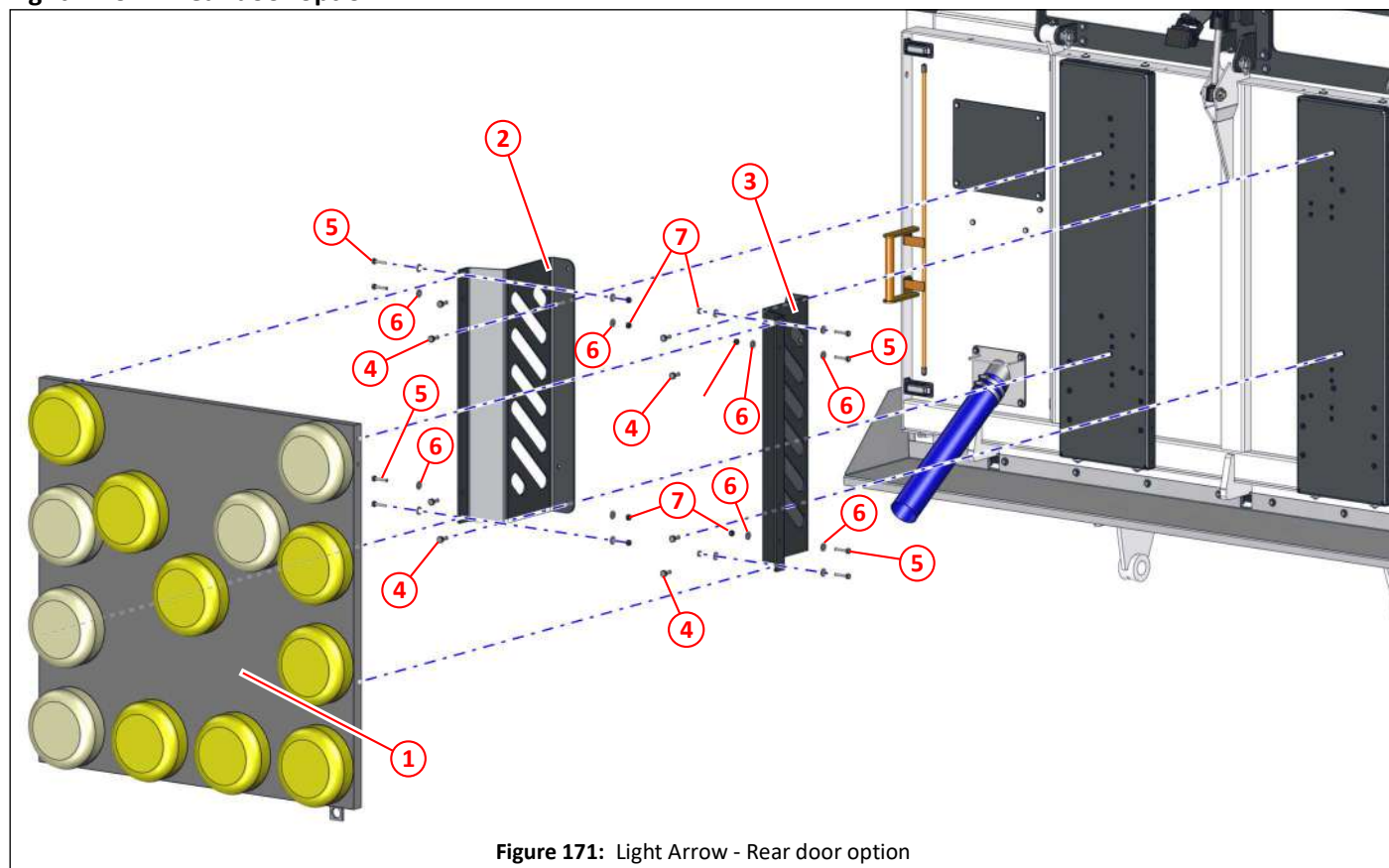

Figure 171: Light Arrow - Rear door option

Item	Part No	Qty	Description
①	042500	1	LP13 Mini Light Arrow, fixed, 24V LED
NI	045565	1	Spare LED bulb for LP13 Mini Light Arrow, 24V
②	042501	1	Mounting bracket, LP13 Mini Light Arrow, left hand
③	042502	1	Mounting bracket, LP13 Mini Light Arrow, right hand
④	000280	8	Setscrew M10 x25, stainless steel
⑤	011014	8	Setscrew M8 x 40, stainless steel
⑥	011092	16	Washer M8
⑦	011073	8	Nyloc nut T M8

Chapter 8 Reflective chevrons for rear panels

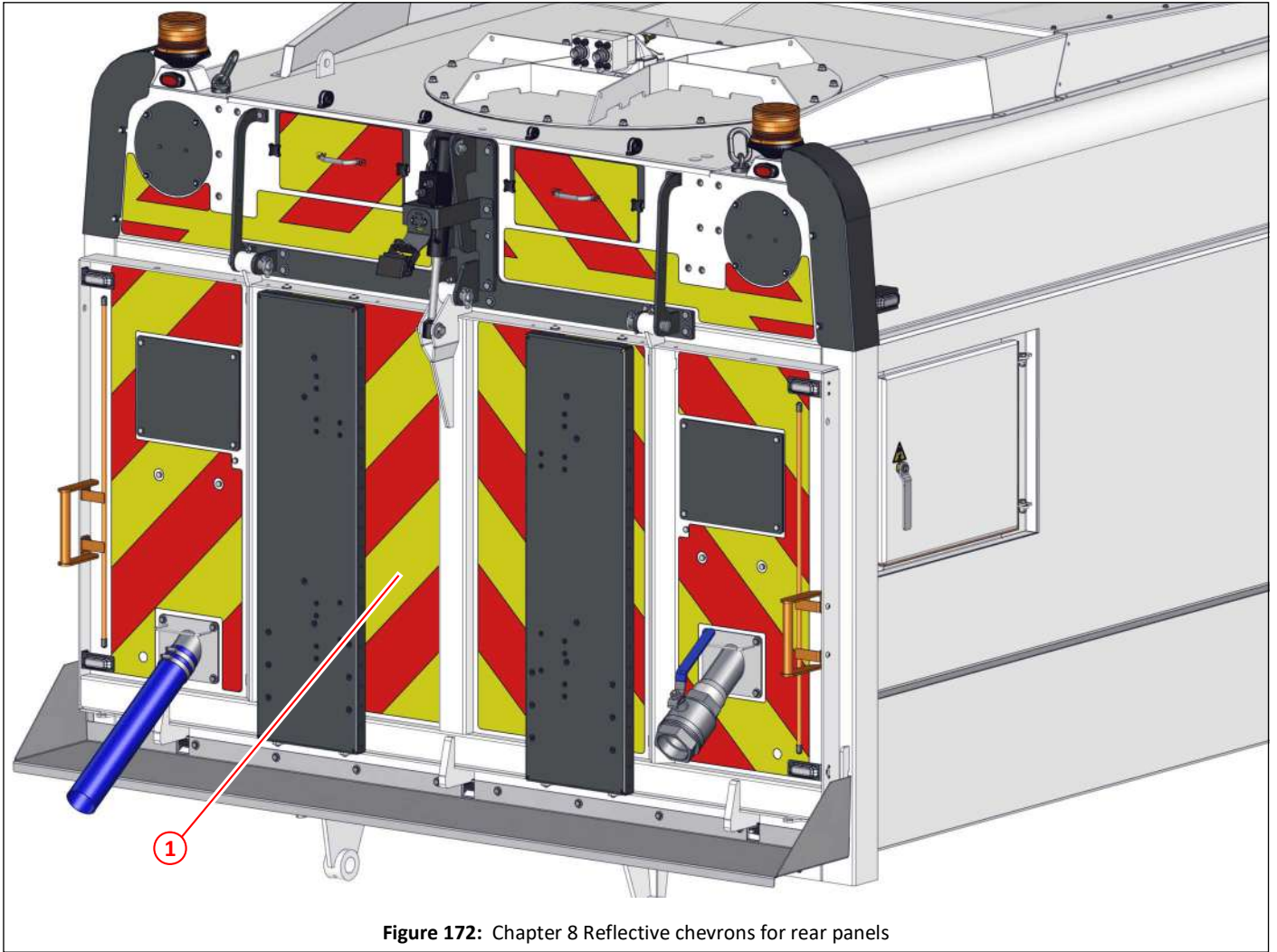

Figure 172: Chapter 8 Reflective chevrons for rear panels

Item	Part No	Qty	Description	
①	047214	1	Chapter 8 Reflective chevrons for rear panels	

Rear door hinge

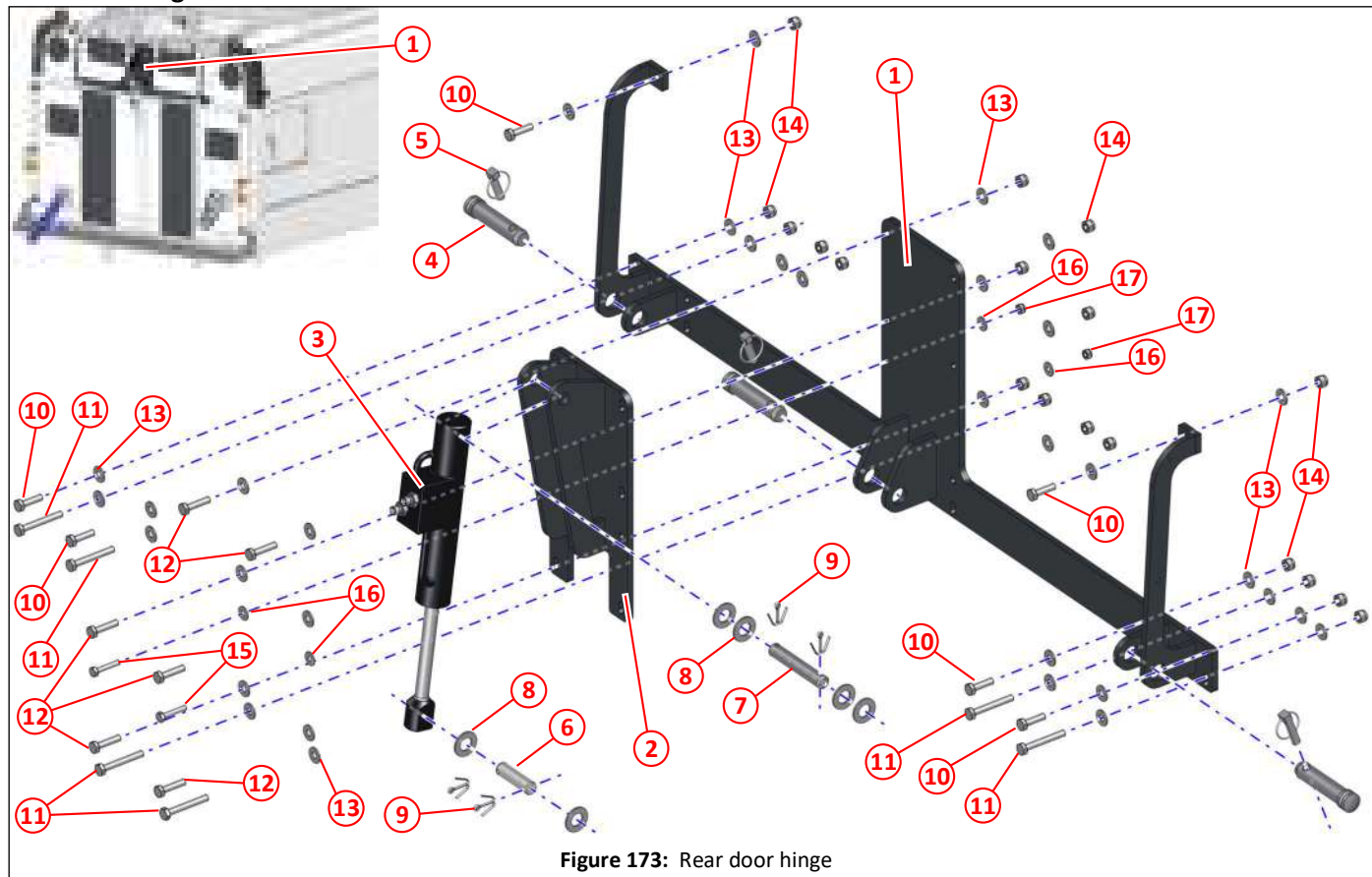
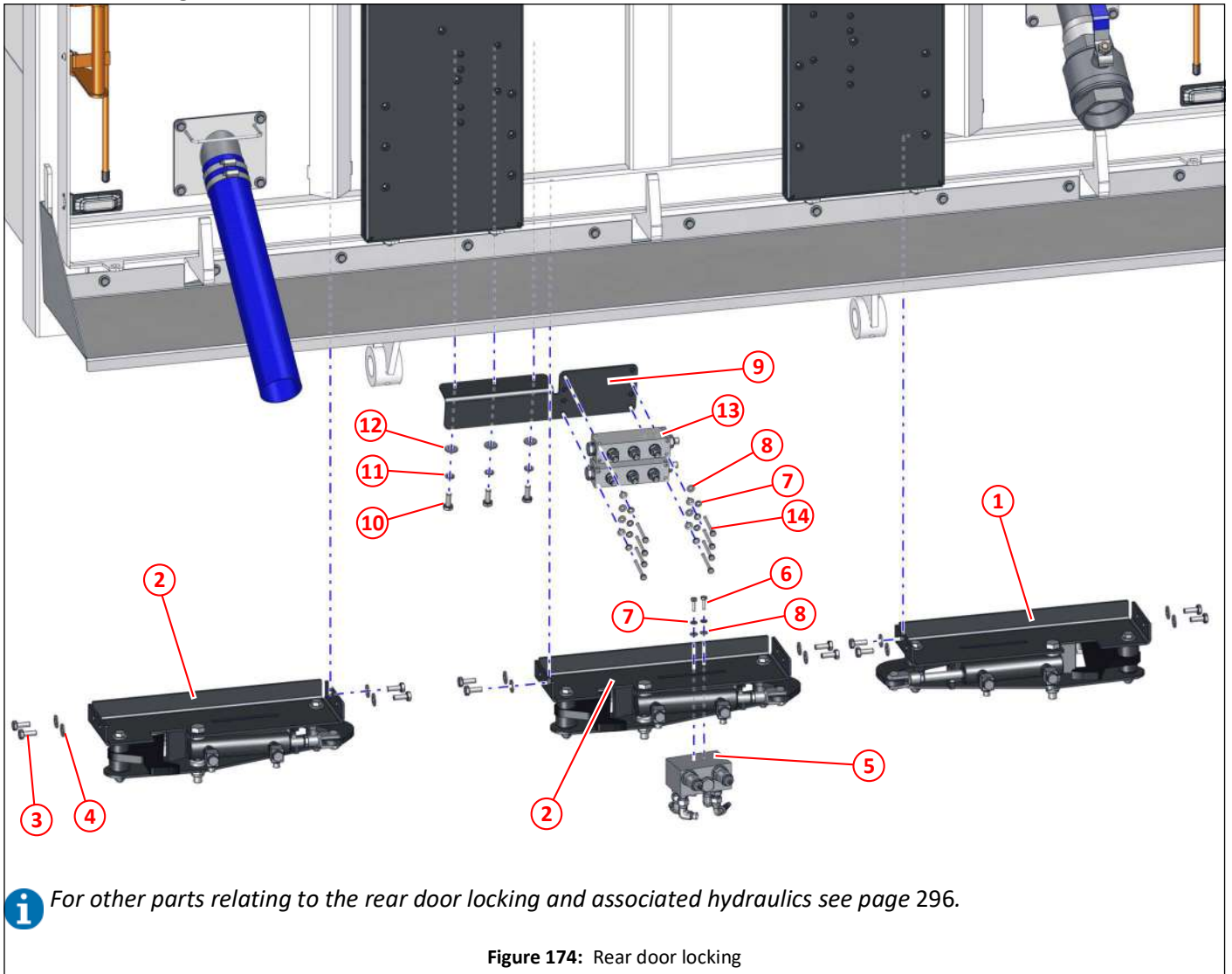

Figure 173: Rear door hinge

Item	Part No	Qty	Description	
①	024345	1	Adjustable hinge plate, rear door	
②	024346	1	Adjustable ram mount, rear door	
③	022511	1	Ram, open/close, rear door	289
④	013051	3	Hinge pin	
⑤	013053	3	Lynch pin	
⑥	014038	1	Pin $\varnothing 20 \times 70$	
⑦	022558	1	Pin, ram, rear door	
⑧	011102	6	Washer M20	
⑨	011122	4	Split pin, $\frac{3}{16}'' \times 1\frac{1}{2}''$	
⑩	011033	6	Setscrew HT M10 x 35	
⑪	011043	6	Bolt HT M10 x 70	
⑫	011034	6	Setscrew M10 x 40	
⑬	011094	34	Washer M8	
⑭	011075	18	Nyloc nut T M10	
⑮	011014	2	Setscrew HT M8 x 40	
⑯	011092	4	Washer M8	
⑰	011073	2	Nyloc nut T M8	

Rear door locking



i For other parts relating to the rear door locking and associated hydraulics see page 296.

Figure 174: Rear door locking

Item	Part No	Qty	Description	
①	048017	1	Rear door locking, right hand, assembly	296,298
②	048018	2	Rear door locking, left hand, assembly	296,299
③	000280	12	Setscrew M10 x 25, stainless steel	
④	000270	12	Washer M10, stainless steel	
⑤	047381	1	Sequence valve, door locking, assembly	297
⑥	011067	2	Setscrew HT M6 x 20	
⑦	011091	10	Spring washer M6	
⑧	011090	10	Washer M6	
⑨	048477	1	Bracket, manifold, door locking	300
⑩	011031	3	Setscrew HT M10 x 25	
⑪	011095	3	Spring washer M10	
⑫	011094	3	Washer M10	
⑬	047246	2	Manifold, door locking, assembly	300
⑭	000018	8	Setscrew HT M6 x 55	

Hopper chute

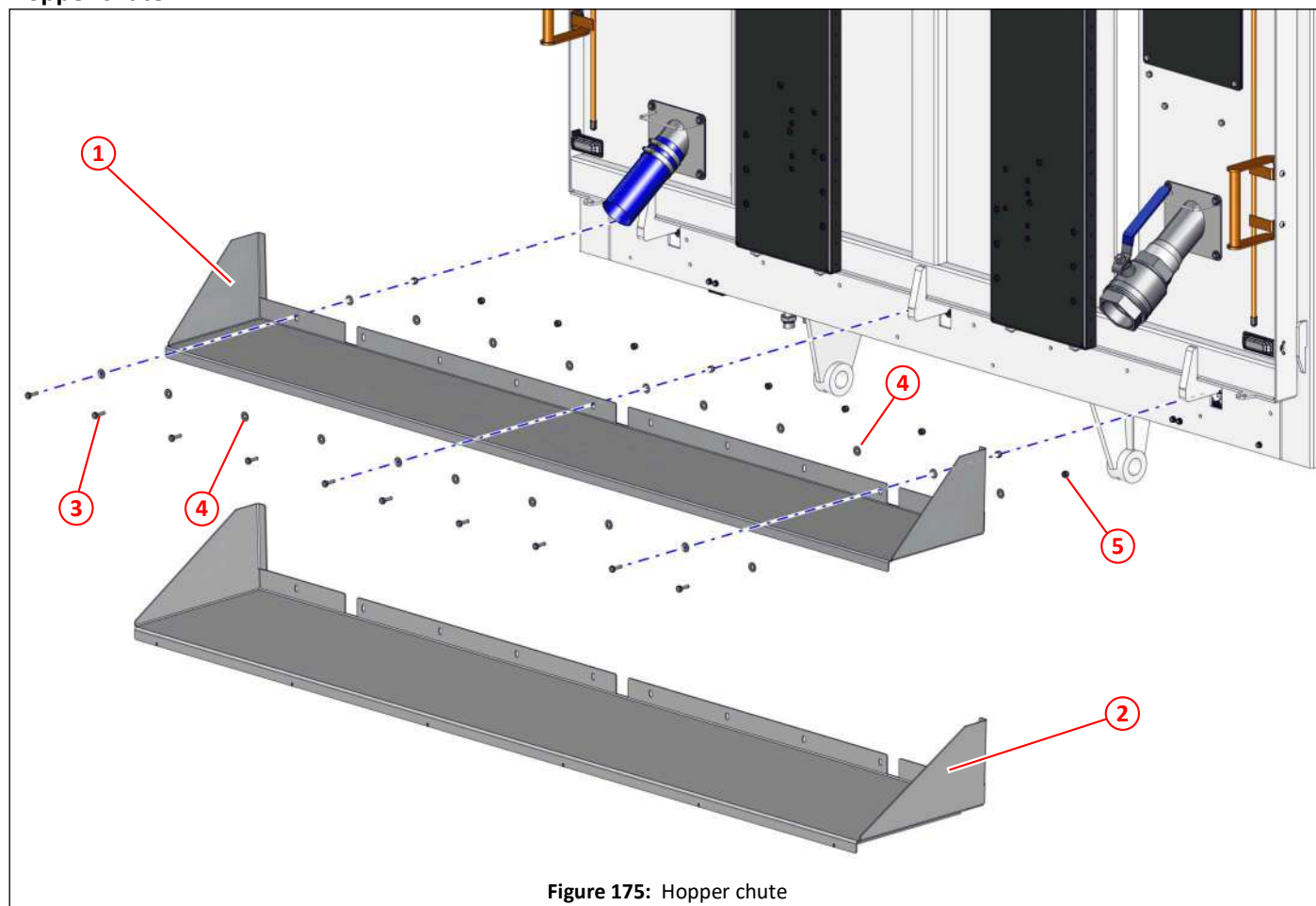

Figure 175: Hopper chute

Item	Part No	Qty	Description
①	046845	1	Hopper chute, large
②	048918	1	Hopper chute 400mm
③	000257	10	Setscrew M8 x 25, stainless steel
④	000264	20	Washer M8, stainless steel
⑤	000263	10	Nyloc nut T M8, stainless steel

Rear camera

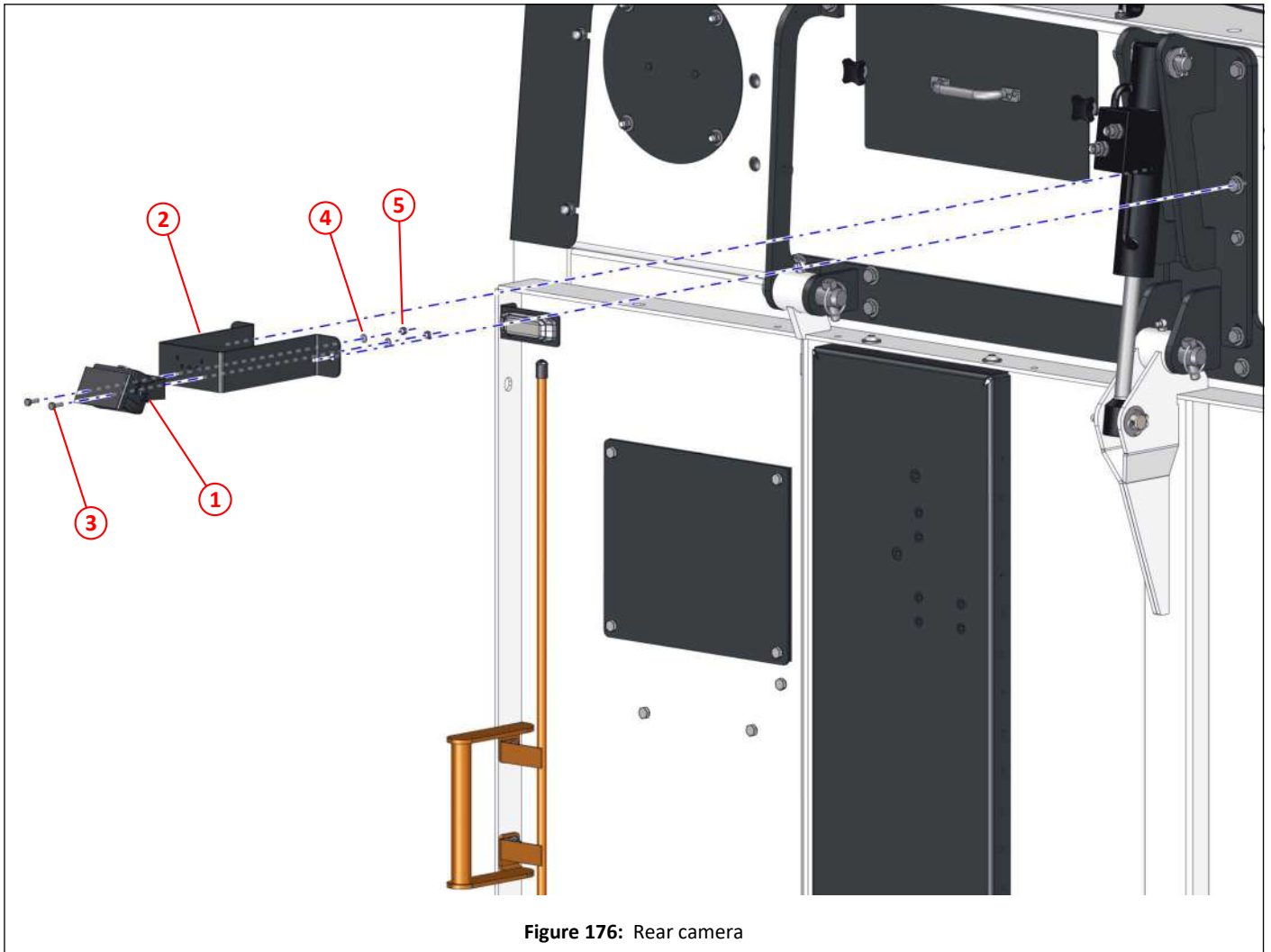

Figure 176: Rear camera

Item	Part No	Qty	Description	
①	040354	1	Camera, (120) VBVC 790C	
②	036437	1	Mount, rear camera	
③	000052	2	Bolt M5 x 16	
④	000410	2	Washer M5	
⑤	000155	2	Nyloc nut M5	

Water

<i>Description</i>	<i>Page</i>
Schematic - Low pressure water, dual sweep, no additional water	206
Schematic - Low and high pressure water, dual sweep, no additional water	208
Schematic - Low and high pressure water, dual sweep, with additional water	210
Water tank	212
Water tank anti-vibration mounts	213
Water tank mounting support plates	214
Water level sight tube, water tank	215
Lid, water tank	216
Fittings, water tank, front	217
Sump fittings and drain, water tank	218
Sump fittings and drain, water tank with auxiliary water tank	220
Fittings, water tank rear	222
Auxiliary water tank, 650 litre (172 US gallons), mounting location	223
Auxiliary water tank arrangement	224
Auxiliary water tank, lower mounting brackets	225
Auxiliary water tank, upper mounting braces	226
Auxiliary water tank, filler lid	227
Auxiliary water tank, water level sight tube	228
Auxiliary water tank, valve fittings	229
Auxiliary water tank, hydrant filler fittings	230
Water strainer and fittings	231
Water strainer, water tank attachment fittings	232
Low pressure water pump mounting	233
Low pressure water pump fittings	234
Water pump, twin diaphragm, low pressure, components	235
Water valves, low pressure, location	236
Water valves, low pressure, assemblies	237
Water valves, low pressure, components	238
Water spray nozzle, twin, side brushes	239
Water spray nozzles, suction nozzle	240
Water spray nozzles, suction spigot	241
Front spray bar, low pressure	242
Over head boom, dust suppression	243
High pressure water pump, mounting	244
High pressure water pump, motor and fittings	245
High pressure water pump, fittings and hoses	246
High pressure water pump 30lpm, seal and repair kits	247
Water manifold (HP) label plate	248
Water manifold (HP) mounting bracket	249
Water manifold (HP) fittings, valves, and hoses	250
Front spray bar, high pressure	252
Hose reel, high pressure	253
Detergent kit	254
Hand lance, water gun	255
Boost spray bar - Rear of LH suction nozzle	256
Boost spray bar - Rear of RH suction nozzle	257
Boost spray bar - Rear of central brush (wide sweep)	258
Suction fan wash assist	259
Water tank filler arrangement	260

Schematic - Low pressure water, dual sweep, no additional water

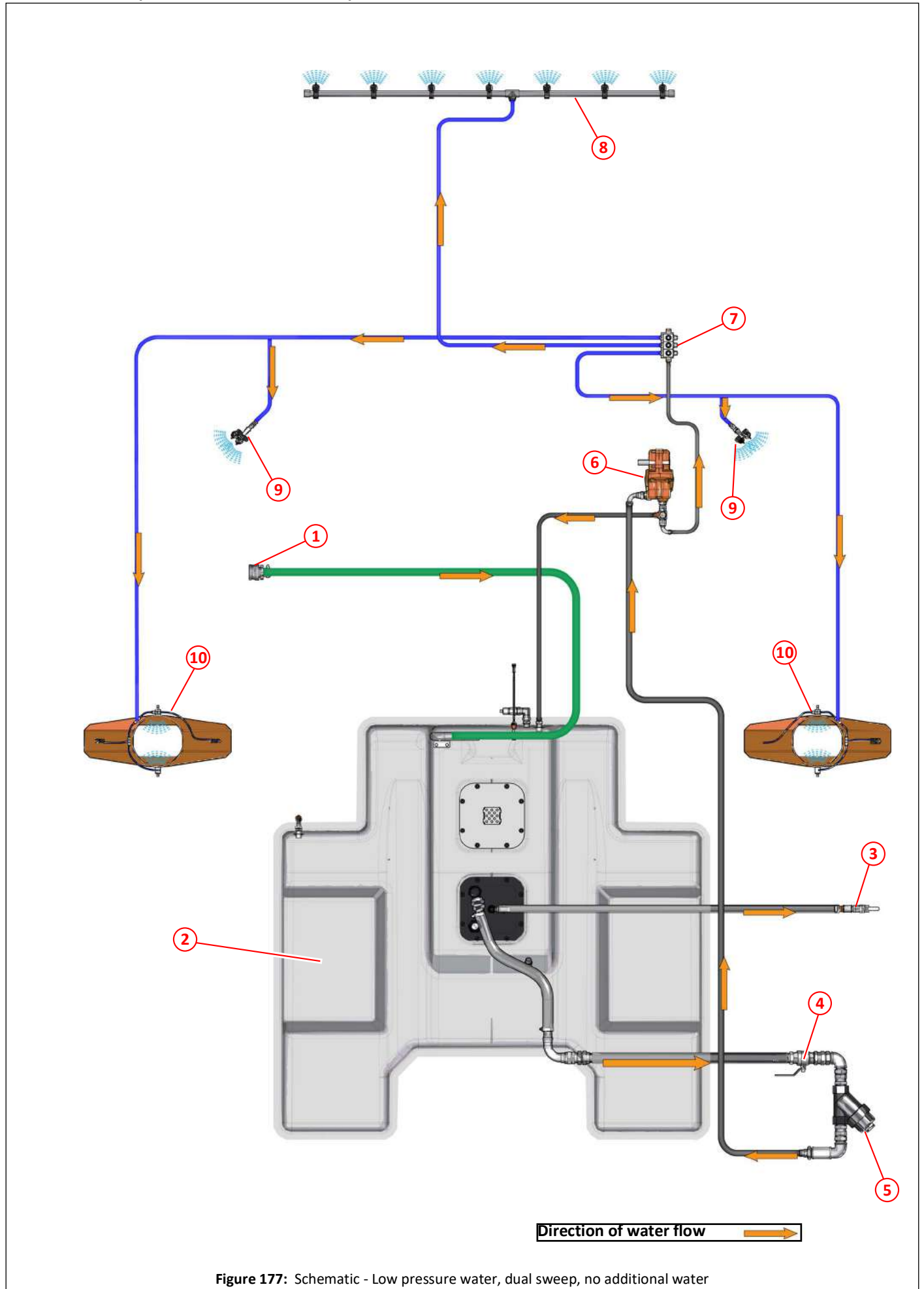

Figure 177: Schematic - Low pressure water, dual sweep, no additional water

Item	Description	
①	Water filler	
②	Water tank	212
③	Drain valve, water tank	218
④	Valve, ball, 1½" BSP, low pressure	231
⑤	Water strainer/filter	231
⑥	Water pump, low pressure	233
⑦	Water control valves, low pressure	236
⑧	Front spray bar, low pressure	242
⑨	Side brush water jets, low pressure	239
⑩	Suction nozzle box water, low pressure	240

Schematic - Low and high pressure water, dual sweep, no additional water

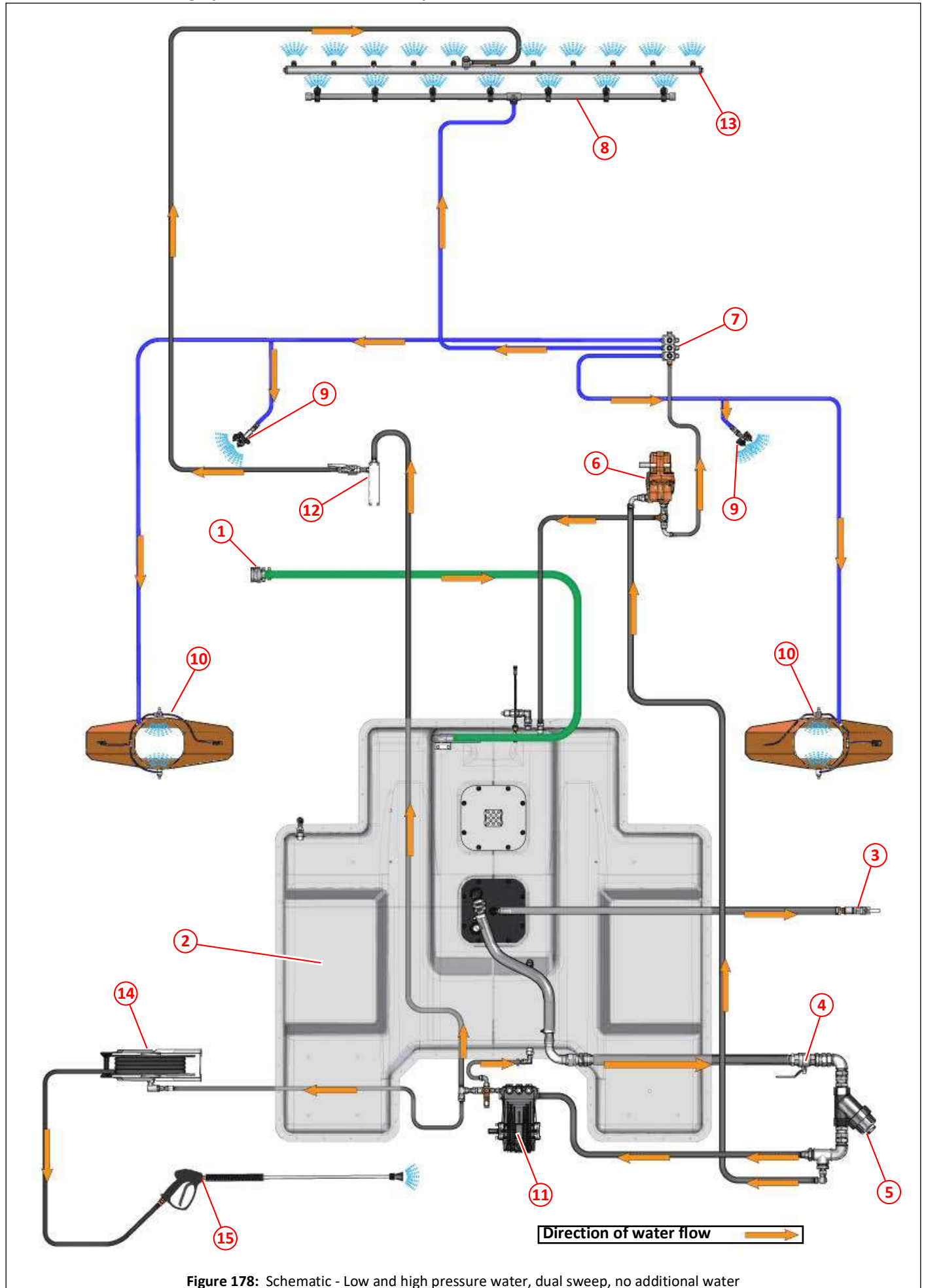

Figure 178: Schematic - Low and high pressure water, dual sweep, no additional water

Item	Description	
①	Water filler	
②	Water tank	212
③	Drain valve, water tank	218
④	Valve, ball, 1½" BSP, low pressure	231
⑤	Water strainer/filter	231
⑥	Water pump, low pressure	233
⑦	Water control valves, low pressure	236
⑧	Front spray bar, low pressure	242
⑨	Side brush water jets, low pressure	239
⑩	Suction nozzle box water, low pressure	240
⑪	Water pump, high pressure	244
⑫	Manifold and valves, high pressure	248
⑬	Front spray bar, high pressure	252
⑭	Hose reel, high pressure	253
⑮	Hand lance, high pressure	255

Schematic - Low and high pressure water, dual sweep, with additional water

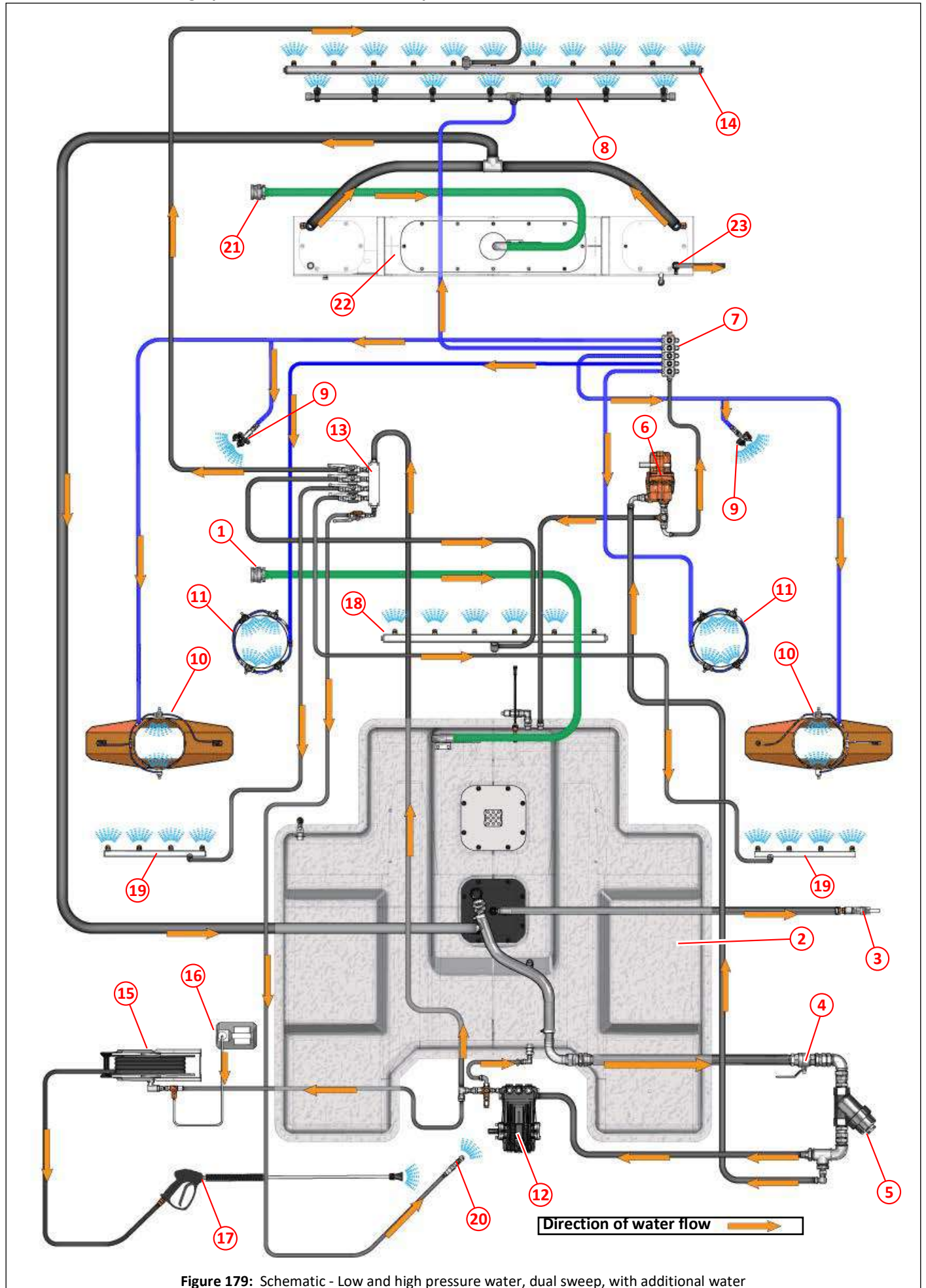

Figure 179: Schematic - Low and high pressure water, dual sweep, with additional water

Item	Description	
①	Water filler	
②	Water tank	212
③	Drain valve, water tank	218
④	Valve, ball, 1½" BSP, low pressure	231
⑤	Water strainer/filter	231
⑥	Water pump, low pressure	233
⑦	Water control valves, low pressure	236
⑧	Front spray bar, low pressure	242
⑨	Side brush water jets, low pressure	239
⑩	Suction nozzle box, low pressure	240
⑪	Suction spigot, low pressure	241
⑫	Water pump, high pressure	244
⑬	Manifold and valves, high pressure	249
⑭	Front spray bar, high pressure	252
⑮	Hose reel, high pressure	253
⑯	Detergent bottle, for hand lance	254
⑰	Hand lance, high pressure	255
⑱	Spray bar, central brush, high pressure	258
⑲	Spray bar, suction nozzle box, high pressure	256,257
⑳	Fan wash assist, high pressure	259
㉑	Water filler, auxiliary water tank	224
㉒	Auxiliary water tank	223
㉓	Drain valve, auxiliary water tank	229

Water tank

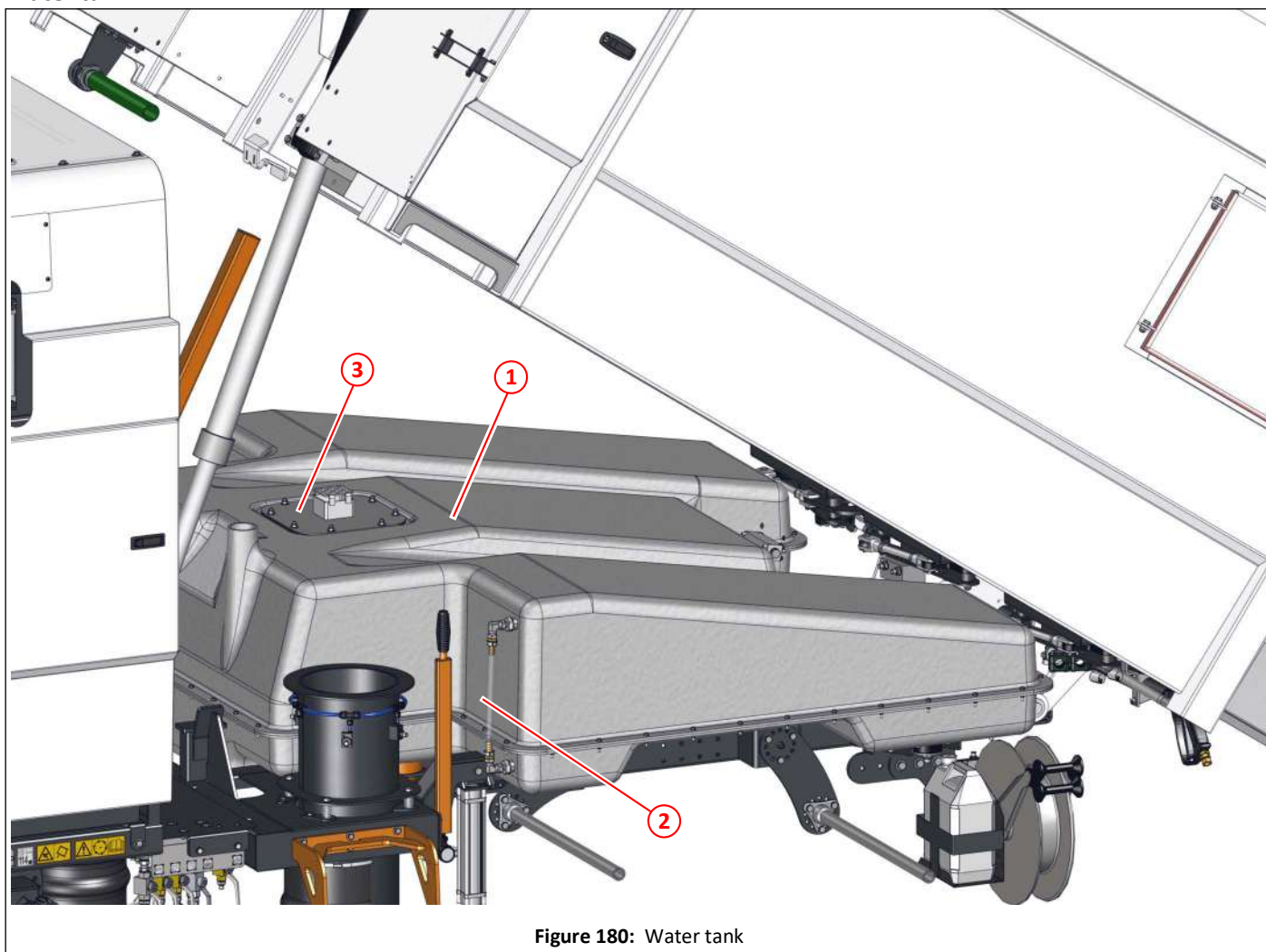

Figure 180: Water tank

Item	Part No	Qty	Description	
①	050809	1	Water tank	213
②			Water level sight tube	215
③	034760	1	Lid water tank	216

Water tank anti-vibration mounts

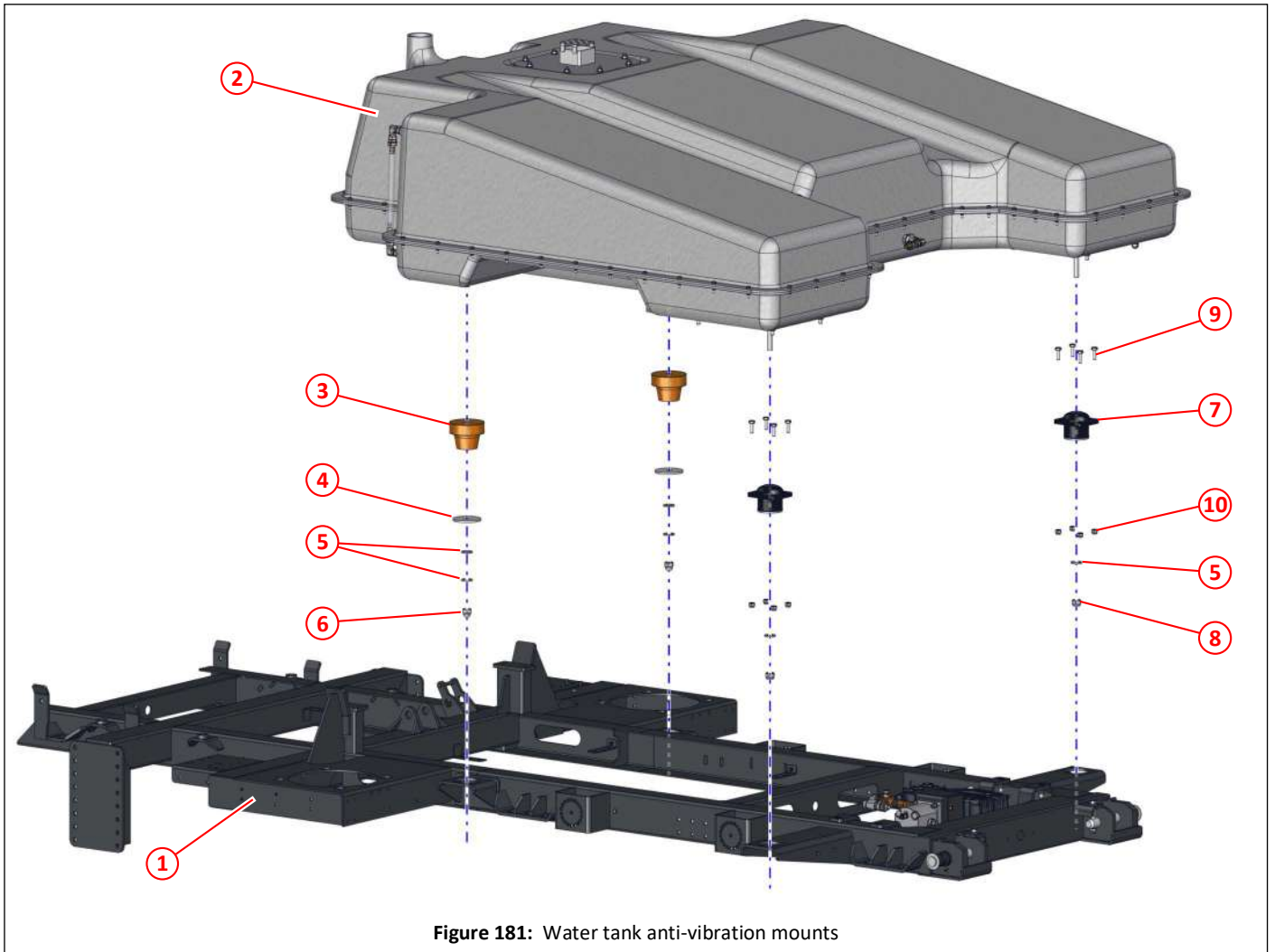

Figure 181: Water tank anti-vibration mounts

Item	Part No	Qty	Description
①	042942	1	Subframe
②	050809	1	Water tank
③	044509	2	Bush, orange, water tank mount
④	044623	2	Washer $\phi 16.5 \times \phi 85 \times 5$
⑤	011135	6	Plain washer M16
⑥	000493	2	Nut, dome, M16, DIN 1587
⑦	033838	2	Mounting, anti-vibration, MS243/5 (HD type), water tank
⑧	011060	2	Nyloc nut T M16
⑨	011032	8	Setscrew M10 x 30
⑩	011075	8	Nyloc nut T M10

Water tank mounting support plates

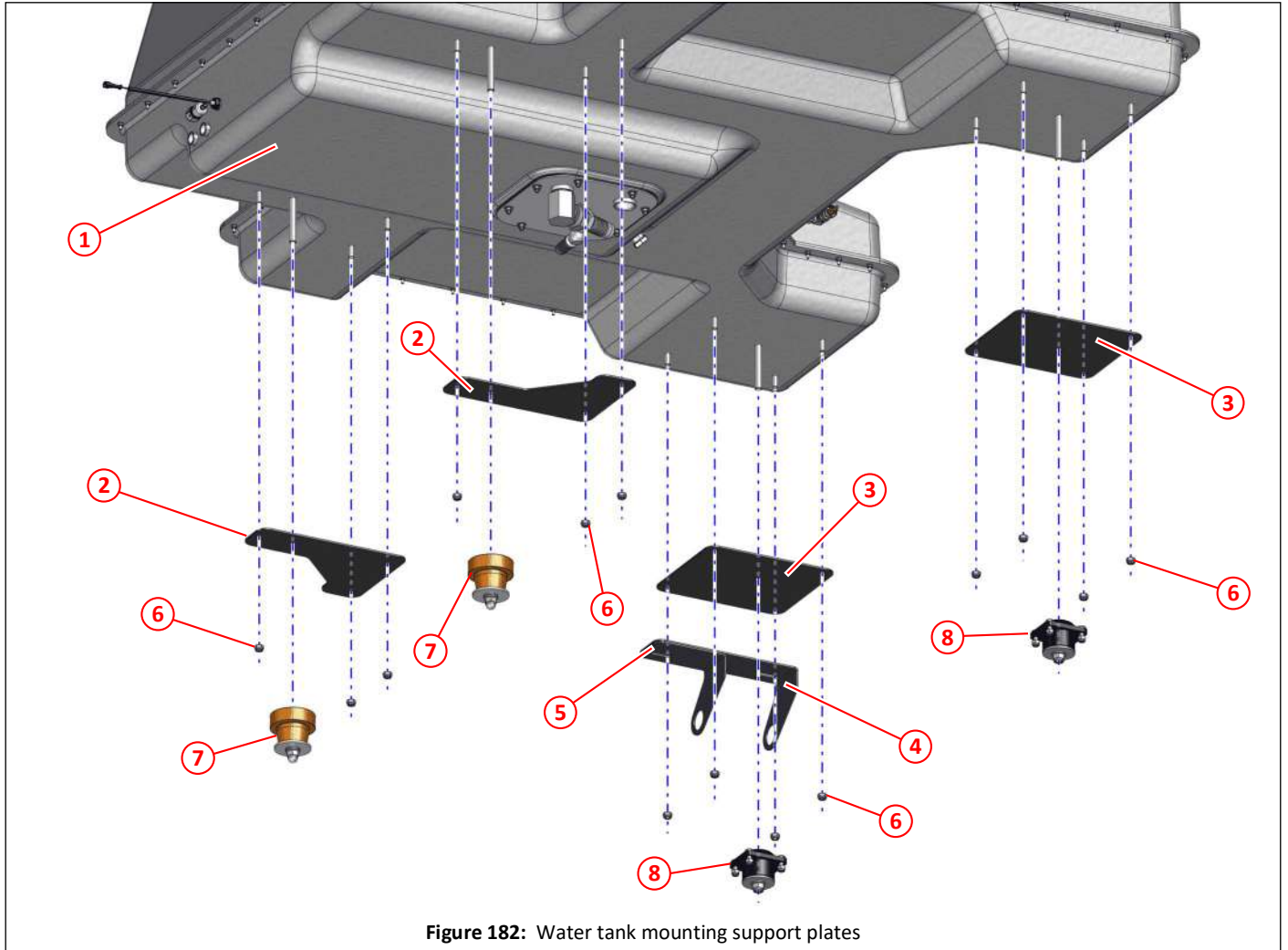

Figure 182: Water tank mounting support plates

Item	Part No	Qty	Description	
①	050809	1	Water tank	213
②	034871	2	Support plate, front	
③	034872	2	Support plate, rear	
④	047426	1	Water filter bracket 1	231
⑤	047427	1	Water filter bracket 2	231
⑥	011077	14	Nyloc nut T M12	
⑦	044509	2	Bush, orange, water tank mount	213
⑧	033838	2	Mounting, anti-vibration, MS243/5 (HD type), water tank	213

Water level sight tube, water tank

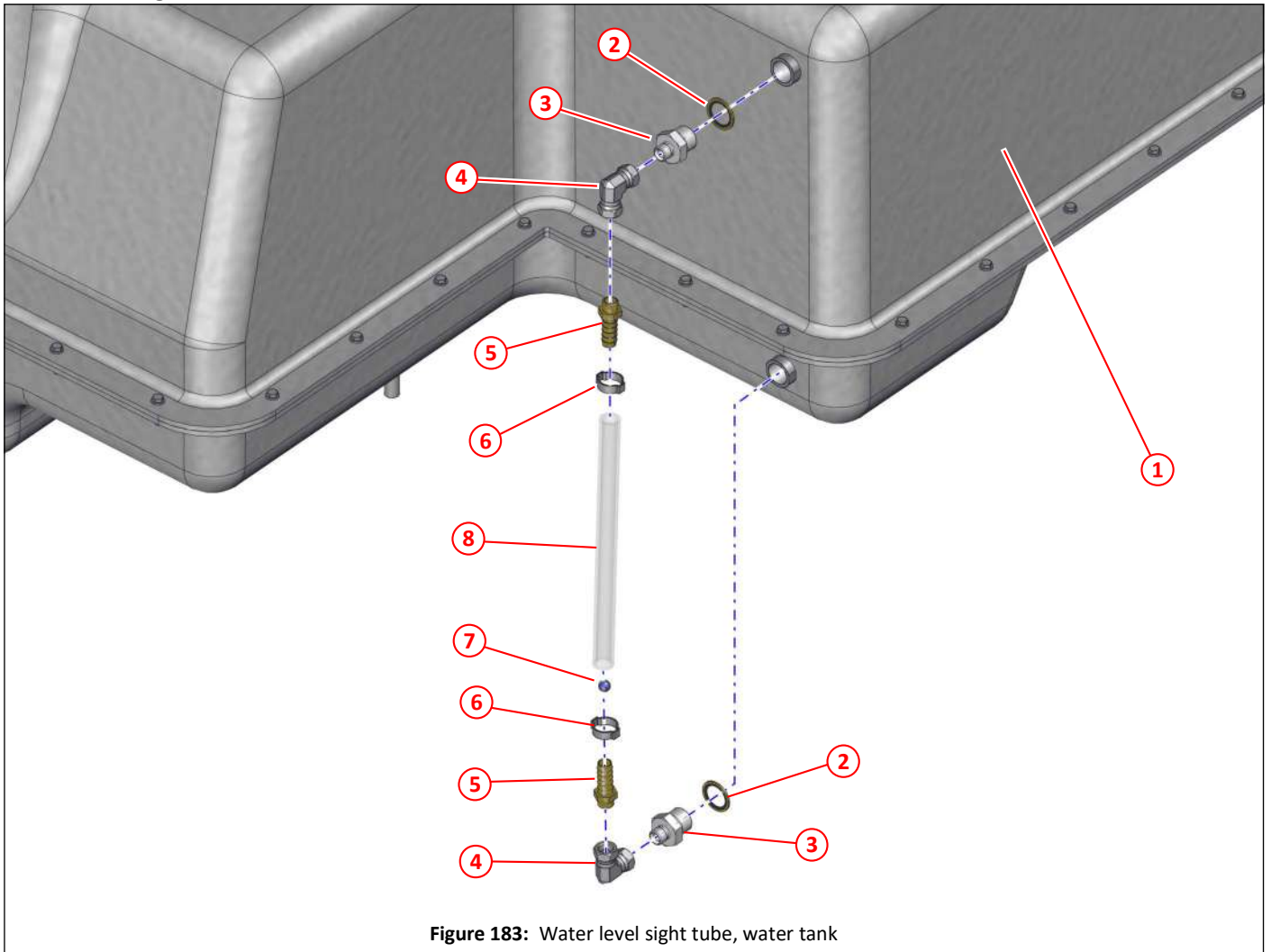

Figure 183: Water level sight tube, water tank

Item	Part No	Qty	Description	
①	050809	1	Water tank	213
②	011155	2	Dowty seal, $\frac{3}{4}$ " BSP	
③	011224	2	Adapter $\frac{3}{4}$ " x $\frac{3}{8}$ " BSP	
④	011205	2	Elbow, swivel, female/female $\frac{3}{8}$ " BSP	
⑤	010930	2	Adapter $\frac{3}{8}$ " BSP x $\frac{5}{8}$ " hose tail	
⑥	000202	2	O-clip $\frac{7}{8}$ "	
⑦	025335	1	Ball, plastic, $\frac{1}{2}$ "	
⑧	040424	1	PVC tube, clear, $\frac{5}{8}$ " , cut to 300mm	

Lid, water tank

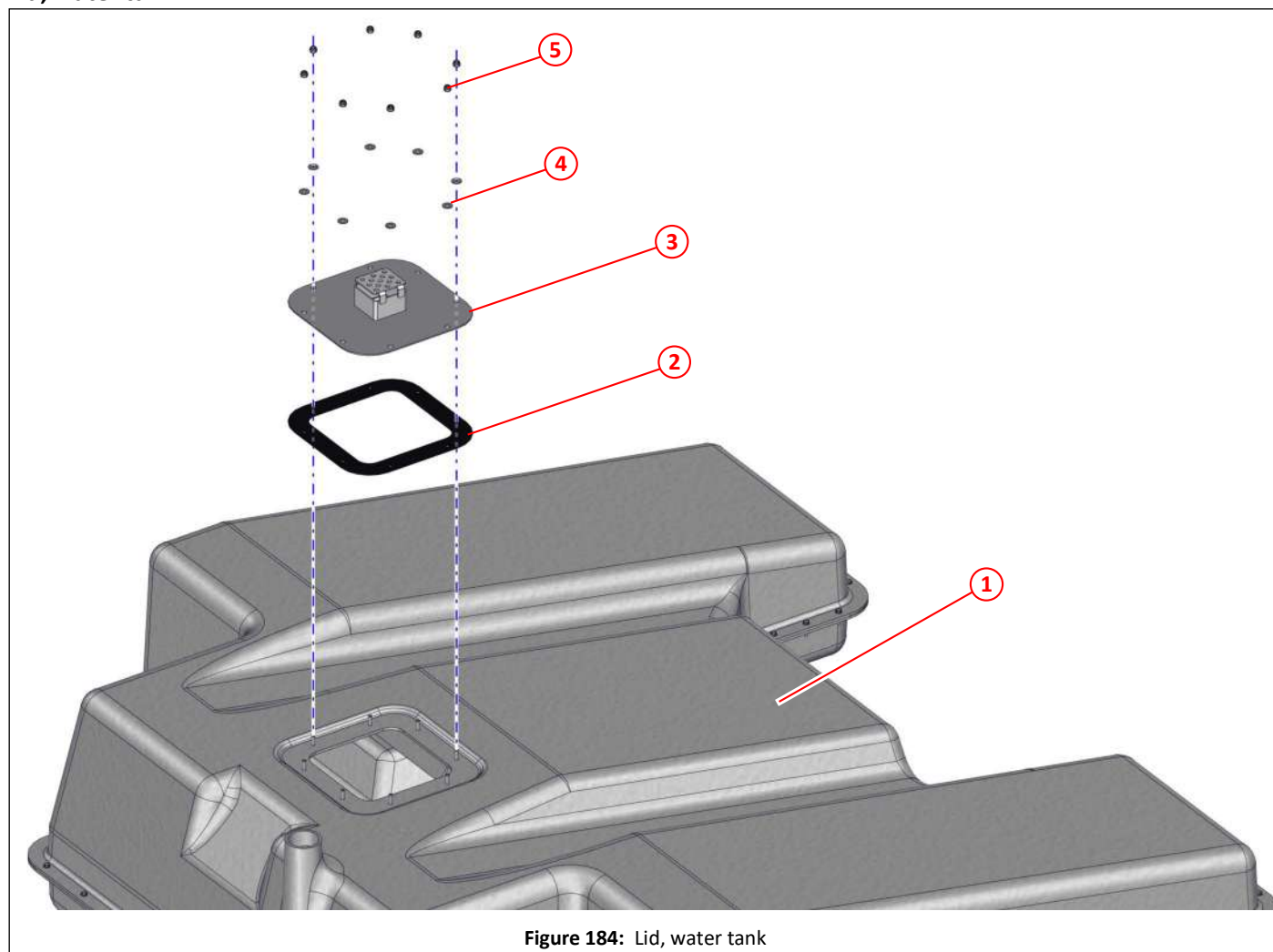

Figure 184: Lid, water tank

Item	Part No	Qty	Description	
①	050809	1	Water tank	213
②	034873	1	Gasket, water tank lid/sump	
③	034760	1	Lid, water tank	
④	000264	8	Washer M8, stainless steel	
⑤	000263	8	Nyloc nut T M8, stainless steel	

Fittings, water tank, front

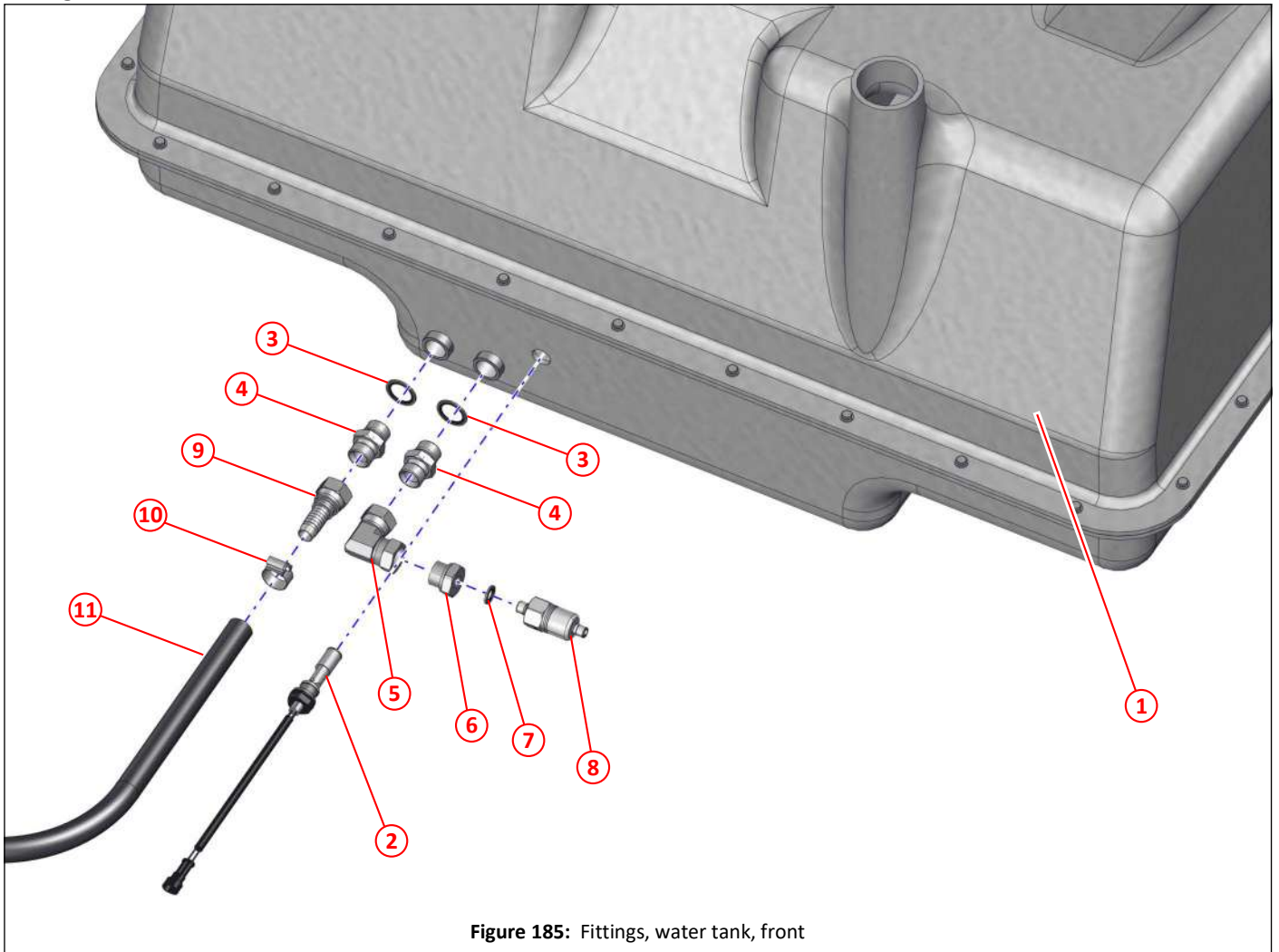
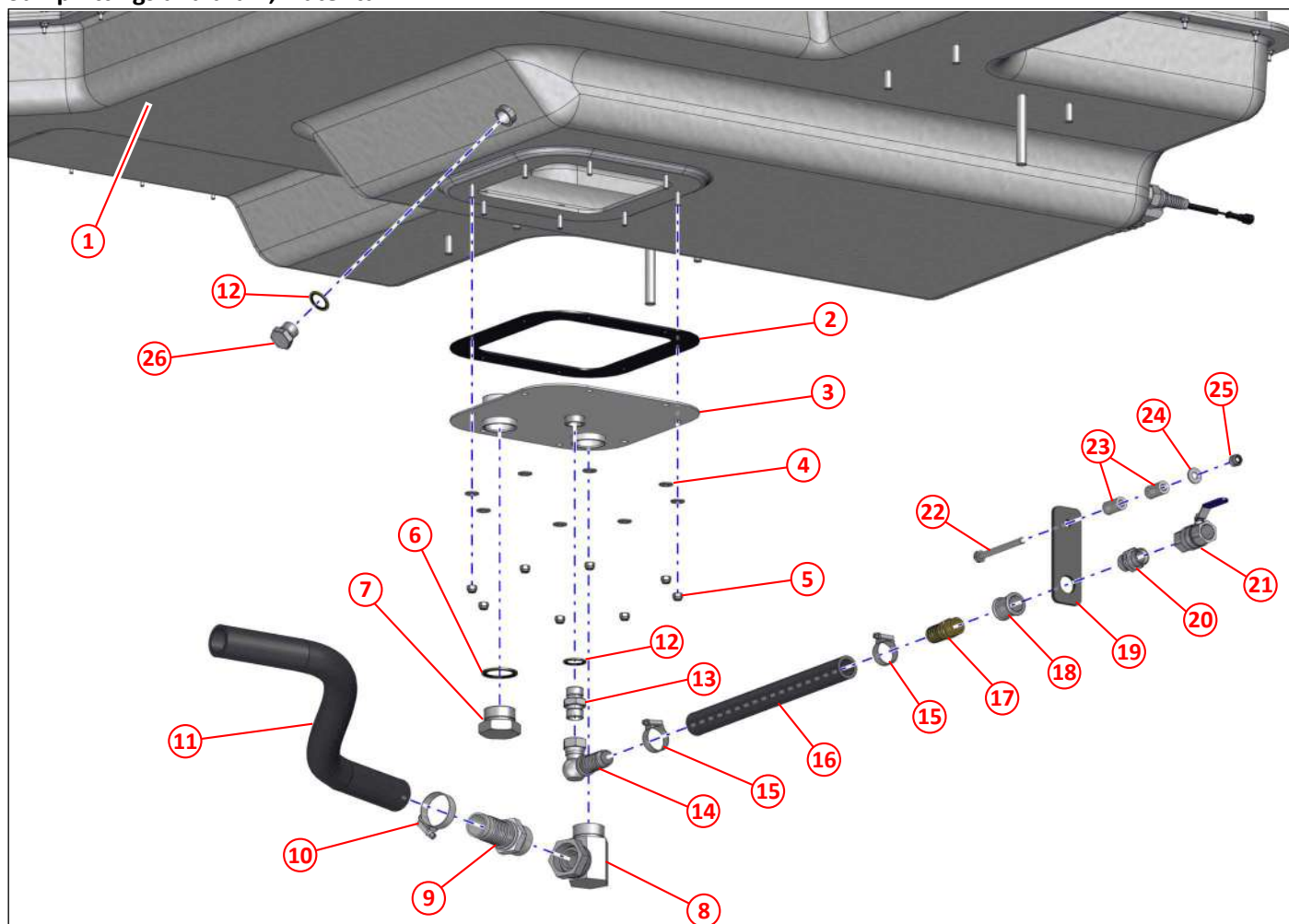

Figure 185: Fittings, water tank, front

Item	Part No	Qty	Description	
①	050809	1	Water tank	213
②	036871	1	Float switch with AMP plug	
③	011155	2	Dowty seal, $\frac{3}{4}$ " BSP	
④	011161	2	Adapter $\frac{3}{4}$ " BSP	
⑤	011213	1	Elbow, swivel, $\frac{3}{4}$ " BSP	
⑥	021524	1	Plug, reducing, $\frac{3}{4}$ " BSP x $\frac{1}{4}$ " BSP	
⑦	011152	1	Dowty seal, $\frac{1}{4}$ " BSP	
⑧	047885	1	Pressure sensor, 0 - 250mBar, $\frac{1}{4}$ " BSP male	
⑨	002249	1	Adapter, straight, $\frac{3}{4}$ " BSP x $\frac{3}{4}$ " hose tail	
⑩	010518	1	Jubilee clip No. 1X [ø30 - ø40]	
⑪	002188	1	Hose $\frac{3}{4}$ " R6, cut to required length, from low pressure water pump	

Sump fittings and drain, water tank



i The sump plate could be in any orientation depending on the chassis being used. Fittings will be the same, but hose lengths could change.

Figure 186: Sump fittings and drain, water tank

Item	Part No	Qty	Description	
①	050809	1	Water tank	213
②	034873	1	Gasket, water tank, lid/sump	
③	046844	1	Sump plate, water tank, large feed	
④	000264	8	Washer M8, stainless steel	
⑤	000263	8	Nyloc nut T M8, stainless steel	
⑥	002072	1	Dowty seal, 1½" BSP	
⑦	002231	1	Plug, 1½" BSP	
⑧	002286	1	Elbow, male with swivel female, 1½" BSP	
⑨	002051	1	Adapter, straight, 1½" BSP x 1½" hose tail	
⑩	005081	1	Jubilee clip, high torque, size 50 ø30-ø50	
⑪	045968	1	Hose, SD MEGAFLEX, ø1½" ø38mm, cut to required length, to water filter	
⑫	011155	2	Dowty seal, ¾" BSP	
⑬	011161	1	Adapter, ¾" BSP	
⑭	002203	1	Elbow, ¾" BSPP to 1" hose tail	
⑮	010518	2	Jubilee clip No. 1X [ø30 - ø40]	
⑯	010959	1	Hose 1", fuel, cut to required length	
⑰	010931	1	Adapter, ¾" BSP x 1" hose tail	
⑱	010934	1	Socket, ¾" BSP	

Item	Part No	Qty	Description	
19	021848	1	Bracket, water tank drain tap mounting	
20	011161	1	Adapter, $\frac{3}{4}$ " BSP	
21	013757	1	Valve, ball, $\frac{3}{4}$ " BSP	
22	011042	1	Bolt, HT, M10 x 110	
23	037723	2	Spacer, $\varnothing 11$ x $\varnothing 20$ x 35.5	
24	000270	1	Washer M10, stainless steel	
25	000269	1	Nyloc nut T M10, stainless steel	
26	011244	1	Plug $\frac{3}{4}$ " BSP	

Sump fittings and drain, water tank with auxiliary water tank

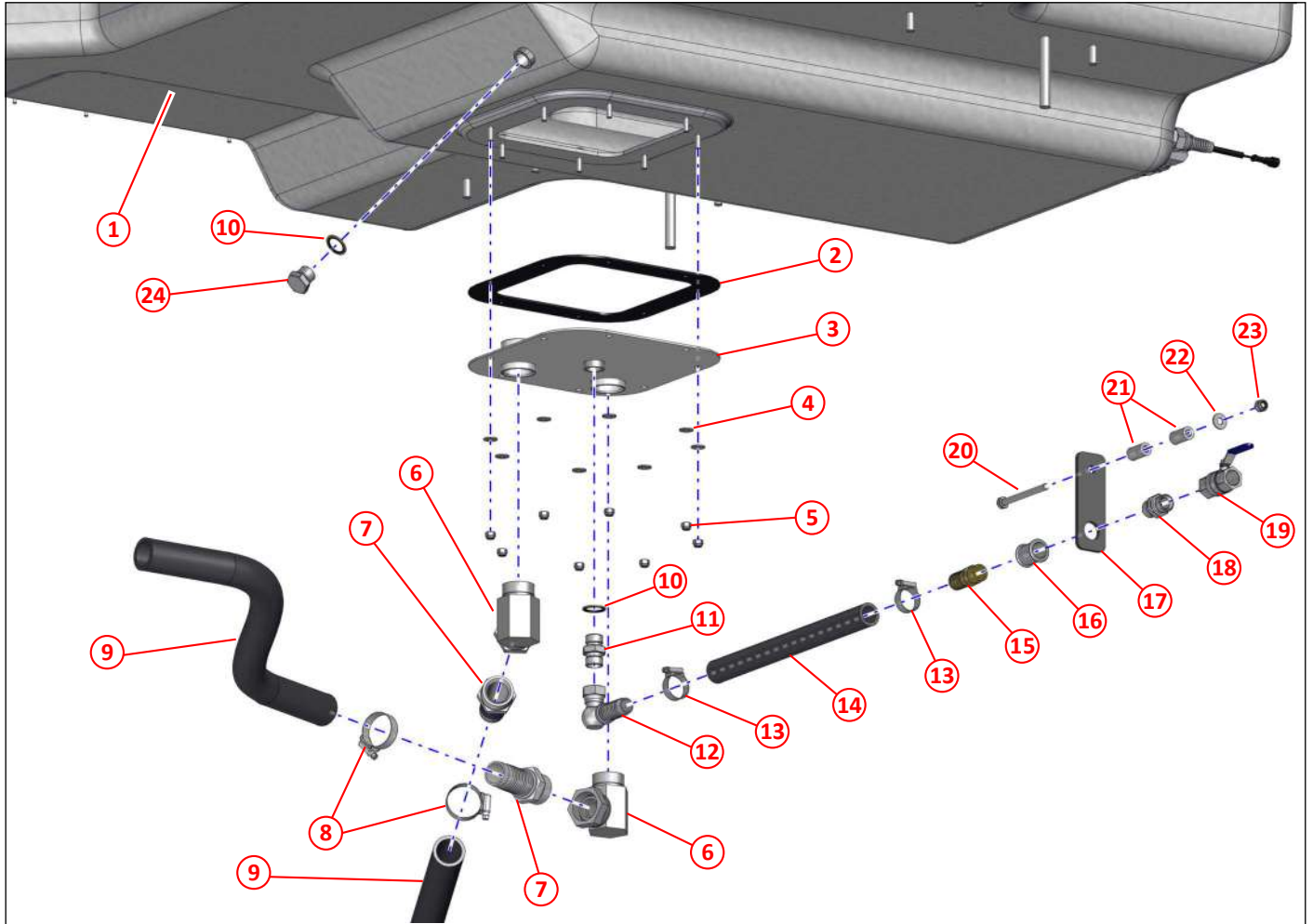

i The sump plate could be in any orientation depending on the chassis being used. Fittings will be the same, but hose lengths could change.

Figure 187: Sump fittings and drain, water tank with auxiliary water tank

Item	Part No	Qty	Description	
①	050809	1	Water tank	213
②	034873	1	Gasket, water tank, lid/sump	
③	046844	1	Sump plate, water tank, large feed	
④	000264	8	Washer M8, stainless steel	
⑤	000263	8	Nyloc nut T M8, stainless steel	
⑥	002286	2	Elbow, male with swivel female, 1½" BSP	
⑦	002051	2	Adapter, straight, 1½" BSP x 1½" hose tail	
⑧	005081	2	Jubilee clip, high torque, size 50 [ø30-ø50]	
⑨	045968	2	Hose, SD MEGAFLEX, ø1½" ø38mm, cut to required length	
⑩	011155	2	Dowty seal, ¾" BSP	
⑪	011161	1	Adapter, ¾" BSP	
⑫	002203	1	Elbow, ¾" BSPP to 1" hose tail	
⑬	010518	2	Jubilee clip No. 1X [ø30 - ø40]	
⑭	010959	1	Hose 1", fuel, cut to required length	
⑮	010931	1	Adapter, ¾" BSP x 1" hose tail	
⑯	010934	1	Socket, ¾" BSP	
⑰	021848	1	Bracket, water tank drain tap mounting	
⑱	011161	1	Adapter, ¾" BSP	

Item	Part No	Qty	Description	
⑲	013757	1	Valve, ball, $\frac{3}{4}$ " BSP	
⑳	011042	1	Bolt, HT, M10 x 110	
㉑	037723	2	Spacer, $\varnothing 11$ x $\varnothing 20$ x 35.5	
㉒	000270	1	Washer M10, stainless steel	
㉓	000269	1	Nyloc nut T M10, stainless steel	
㉔	011244	1	Plug, $\frac{3}{4}$ " BSP	

Fittings, water tank rear

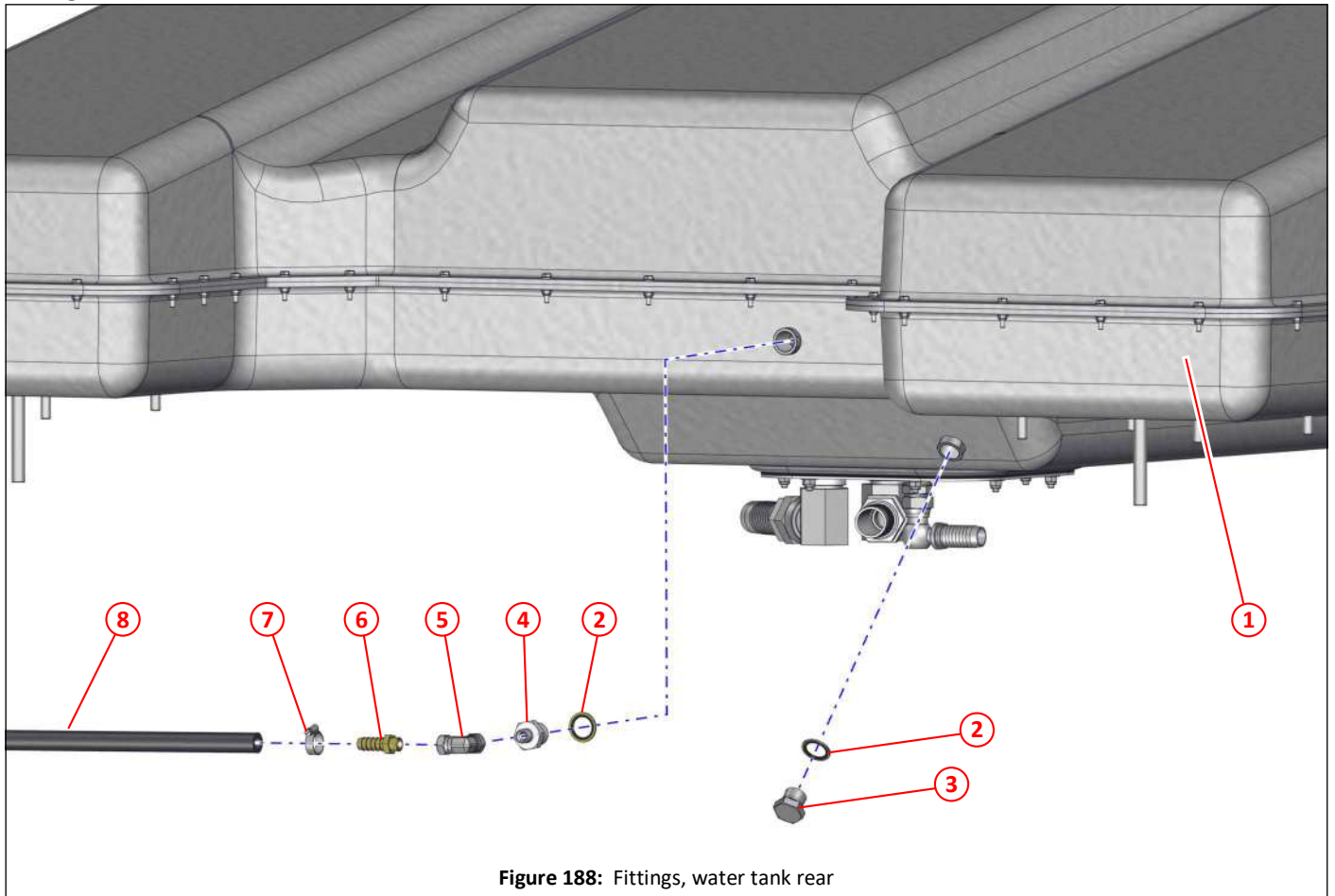

Figure 188: Fittings, water tank rear

Item	Part No	Qty	Description	
①	050809	1	Water tank	213
②	011155	2	Dowty seal, $\frac{3}{4}$ " BSP	
③	011244	1	Plug, $\frac{3}{4}$ " BSP	
④	011224	1	Adapter, $\frac{3}{4}$ " x $\frac{3}{8}$ " BSP	
⑤	011205	1	Elbow, swivel, female/female $\frac{3}{8}$ " BSP	
⑥	010930	1	Adapter, $\frac{3}{8}$ " BSP x $\frac{5}{8}$ " hose tail	
⑦	010517	1	Jubilee clip, No. 0X [ø18 - ø25]	
⑧	011000	1	Hose, $\frac{5}{8}$ " , fuel SAE100R6, cut to length required, from HP water pump	

Auxiliary water tank, 650 litre (172 US gallons), mounting location

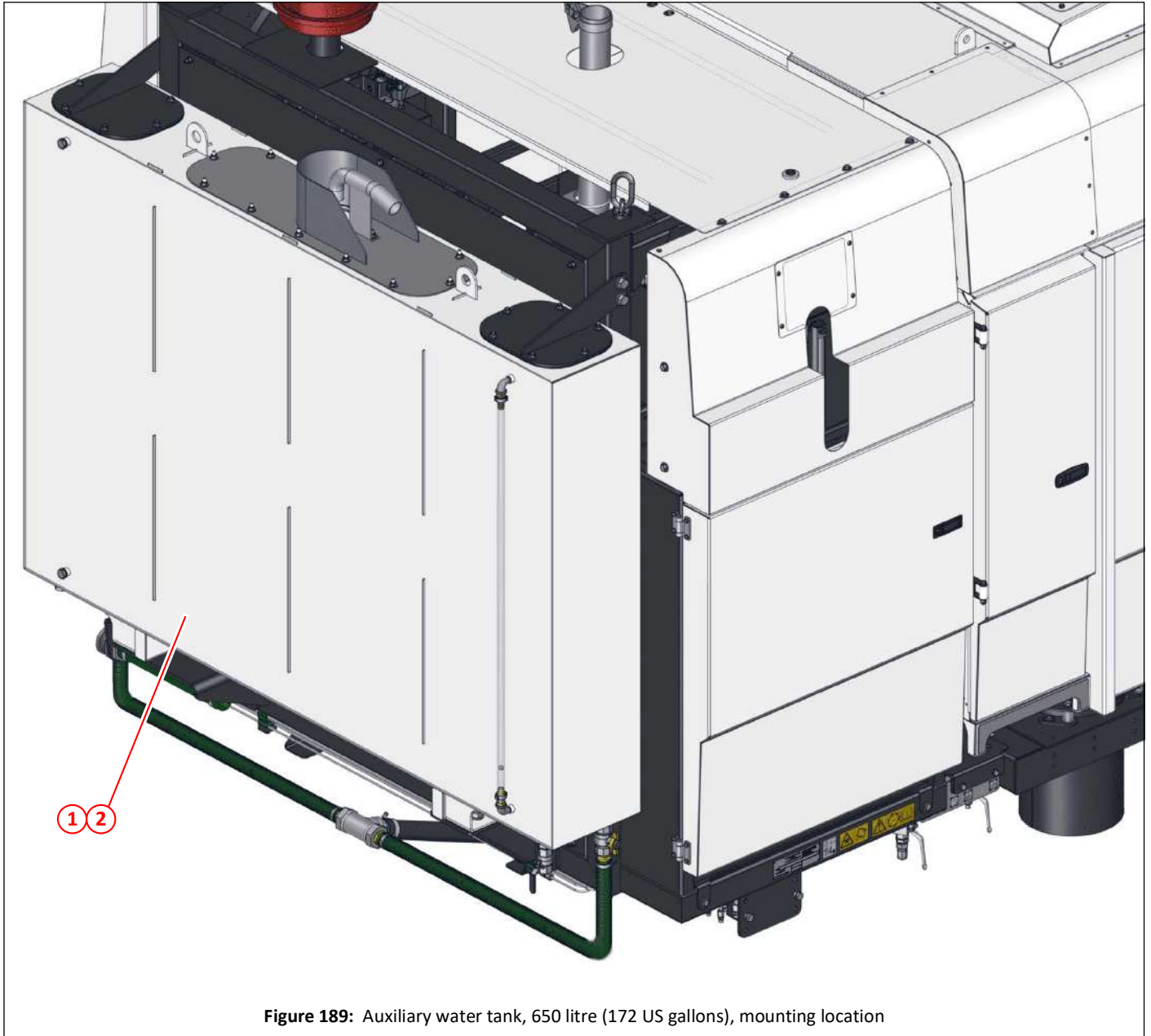

Figure 189: Auxiliary water tank, 650 litre (172 US gallons), mounting location

Item	Part No	Qty	Description
①	043134	1	Auxiliary water tank 650 litre (US 172 gallons), with fittings
②	043104	1	Auxiliary water tank 650 litre (US 172 gallons), no fittings

Auxiliary water tank arrangement

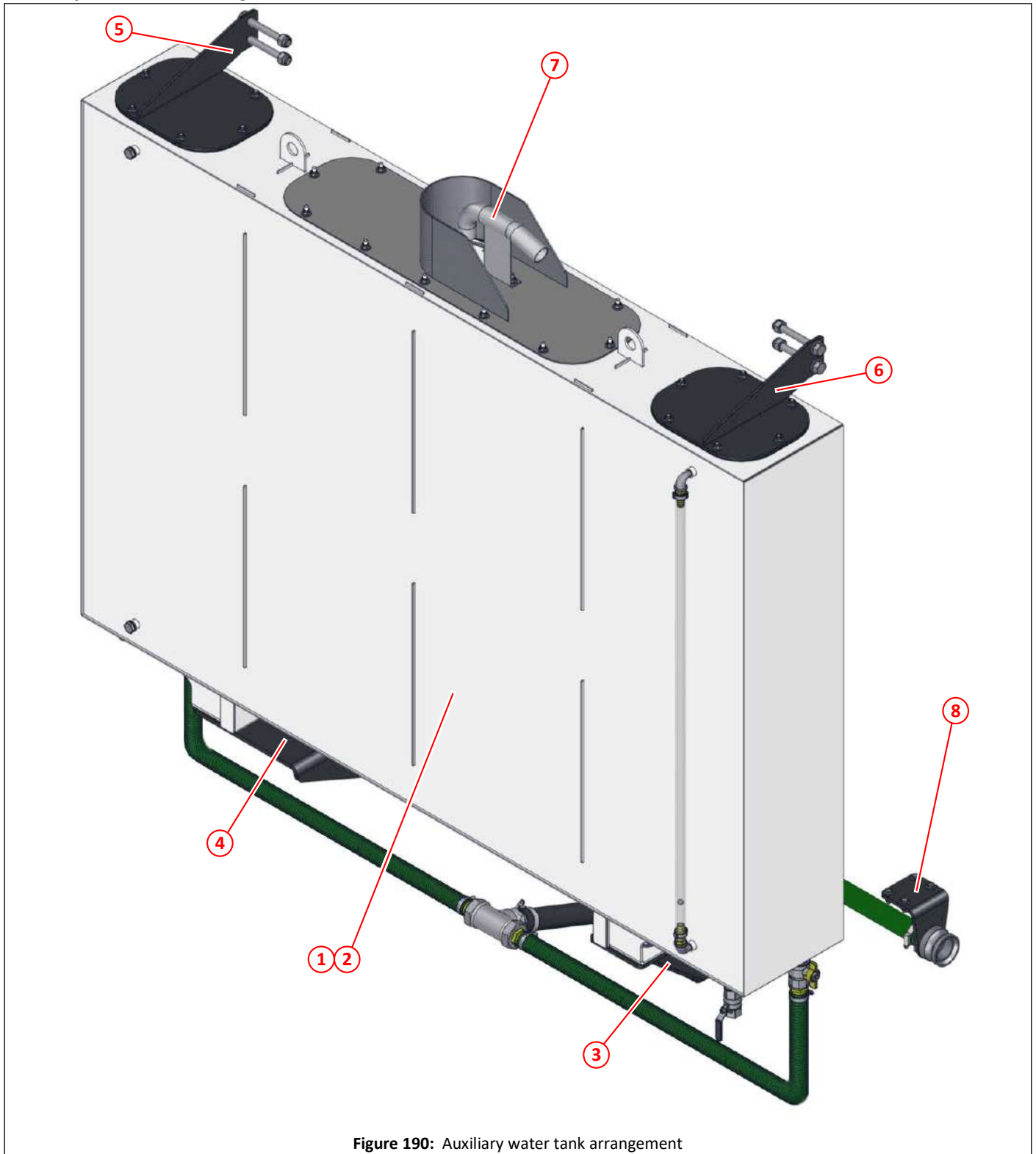

Figure 190: Auxiliary water tank arrangement

Item	Part No	Qty	Description	
①	043134	1	Auxiliary water tank 650 litre (US 172 gallons), with fittings	
②	043104	1	Auxiliary water tank 650 litre (US 172 gallons), no fittings	
③	043135	1	Mounting bracket, left hand, auxiliary water tank	225
④	043136	1	Mounting Bracket, right hand, auxiliary water tank	225
⑤	045153	1	Brace, right hand, auxiliary water tank	226
⑥	045154	1	Brace, left hand, auxiliary water tank	226
⑦	024586	1	Tank filler pipe	
⑧			Hydrant filler, can be on either side of the sweeper	230

Auxiliary water tank, lower mounting brackets

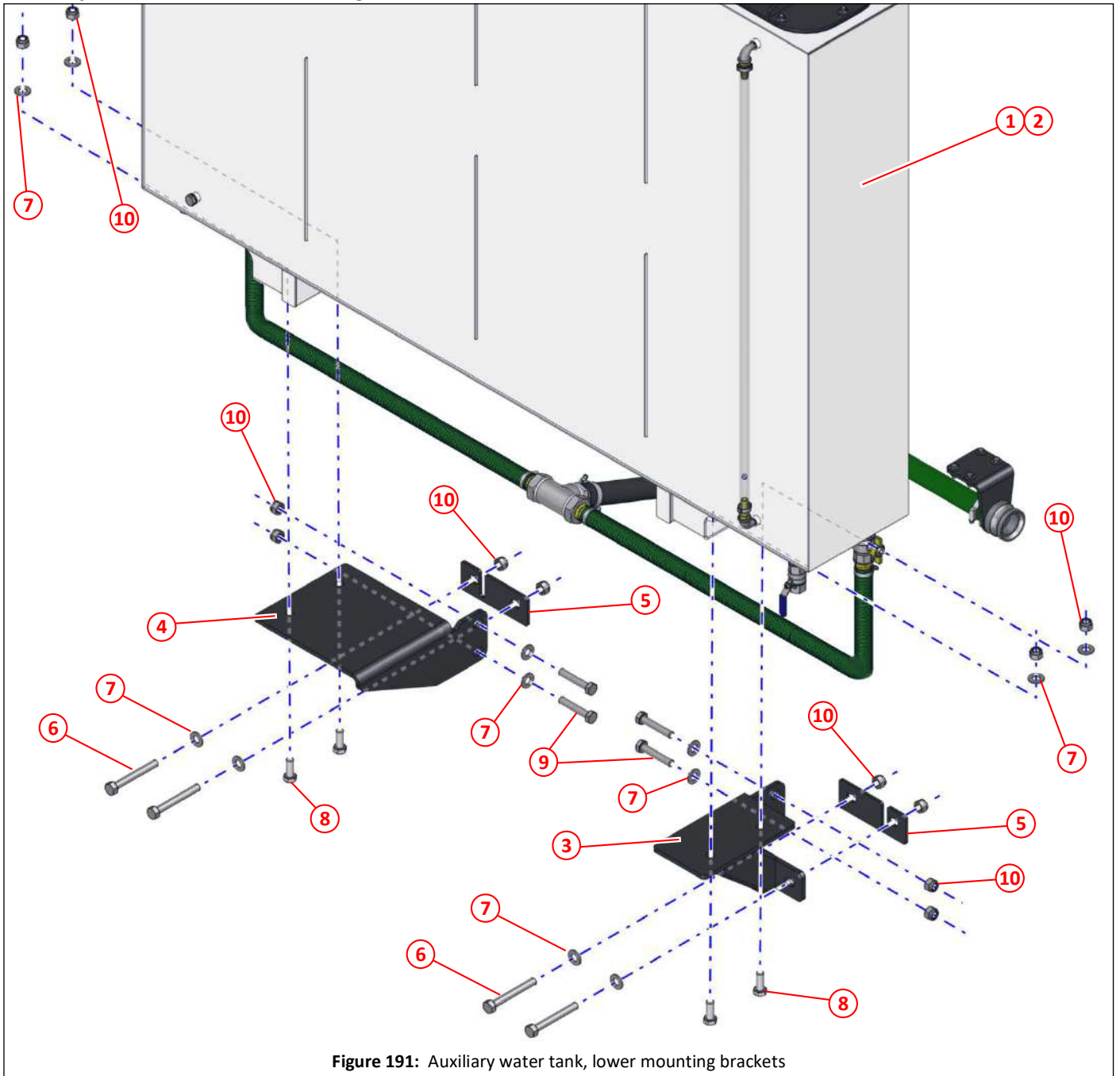

Figure 191: Auxiliary water tank, lower mounting brackets

Item	Part No	Qty	Description
①	043134	1	Auxiliary water tank 650 litre (US 172 gallons), with fittings
②	043104	1	Auxiliary water tank 650 litre (US 172 gallons), no fittings
③	043135	1	Mounting bracket, left hand, auxiliary water tank
④	043136	1	Mounting Bracket, right hand, auxiliary water tank
⑤	045127	2	Water tank plate
⑥	000184	4	Bolt M16 x 120 grade 10.9, plated
⑦	011135	12	Washer M61
⑧	000386	4	Bolt M16 x 40 x 1.5 pitch
⑨	011261	4	Bolt M16 x 80
⑩	011060	12	Nyloc nut T M16

Auxiliary water tank, upper mounting braces

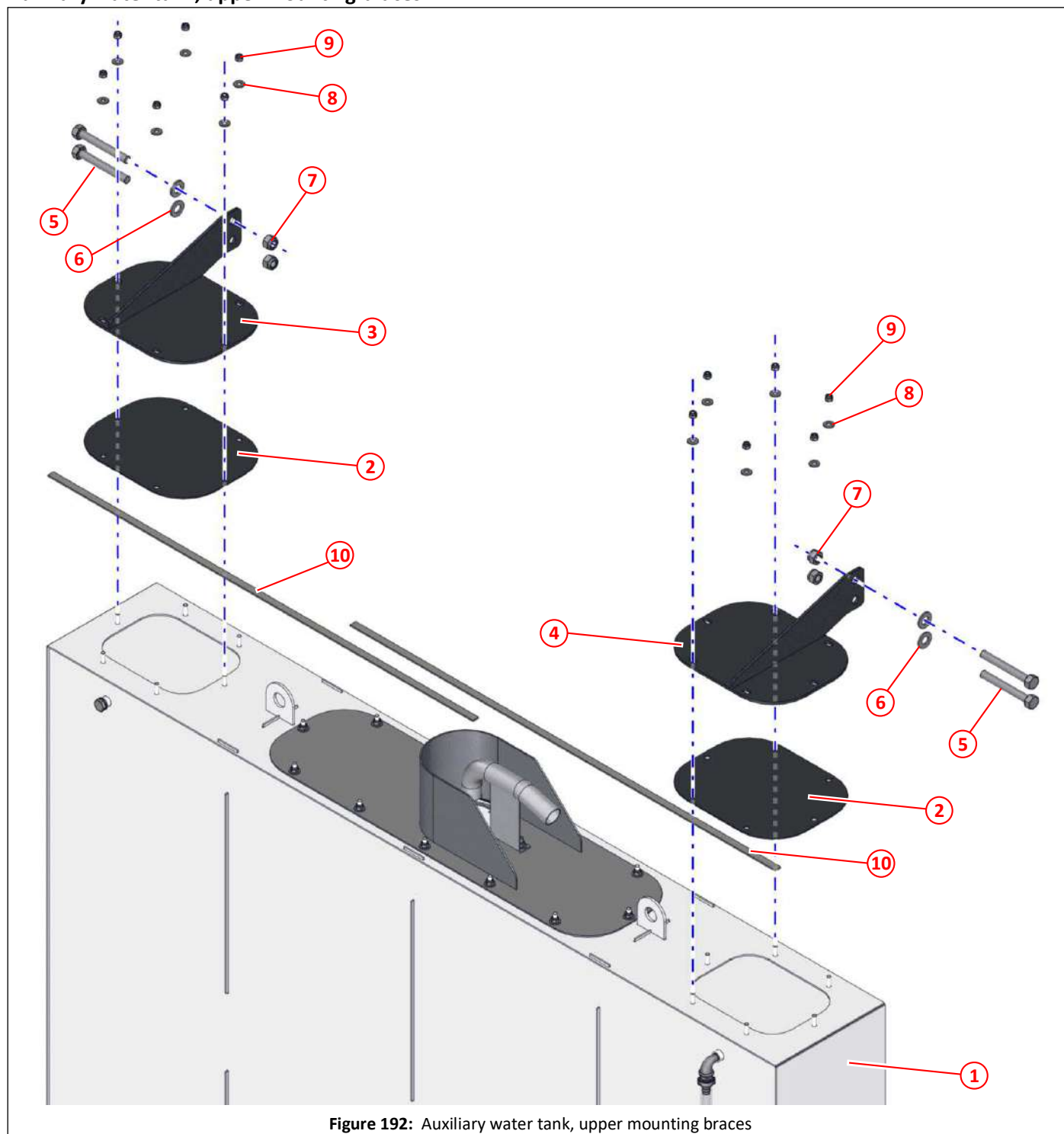

Figure 192: Auxiliary water tank, upper mounting braces

Item	Part No	Qty	Description
①	043104	1	Auxiliary water tank 650 litre (US 172 gallons), no fittings
②	039877	2	Auxiliary water tank lid, small
③	045153	1	Brace, right hand, auxiliary water tank
④	045154	1	Brace, left hand, auxiliary water tank
⑤	000184	4	Bolt M16 x 120, grade 10.9, plated
⑥	011135	4	Washer M16
⑦	011060	4	Nyloc nut T M16
⑧	000264	12	Washer M8, stainless steel
⑨	000263	12	Nyloc nut T M8, stainless steel
⑩	020362	2	Inseal strip 3 x 15, cut to 1110, placed under small lids

Auxiliary water tank, filler lid

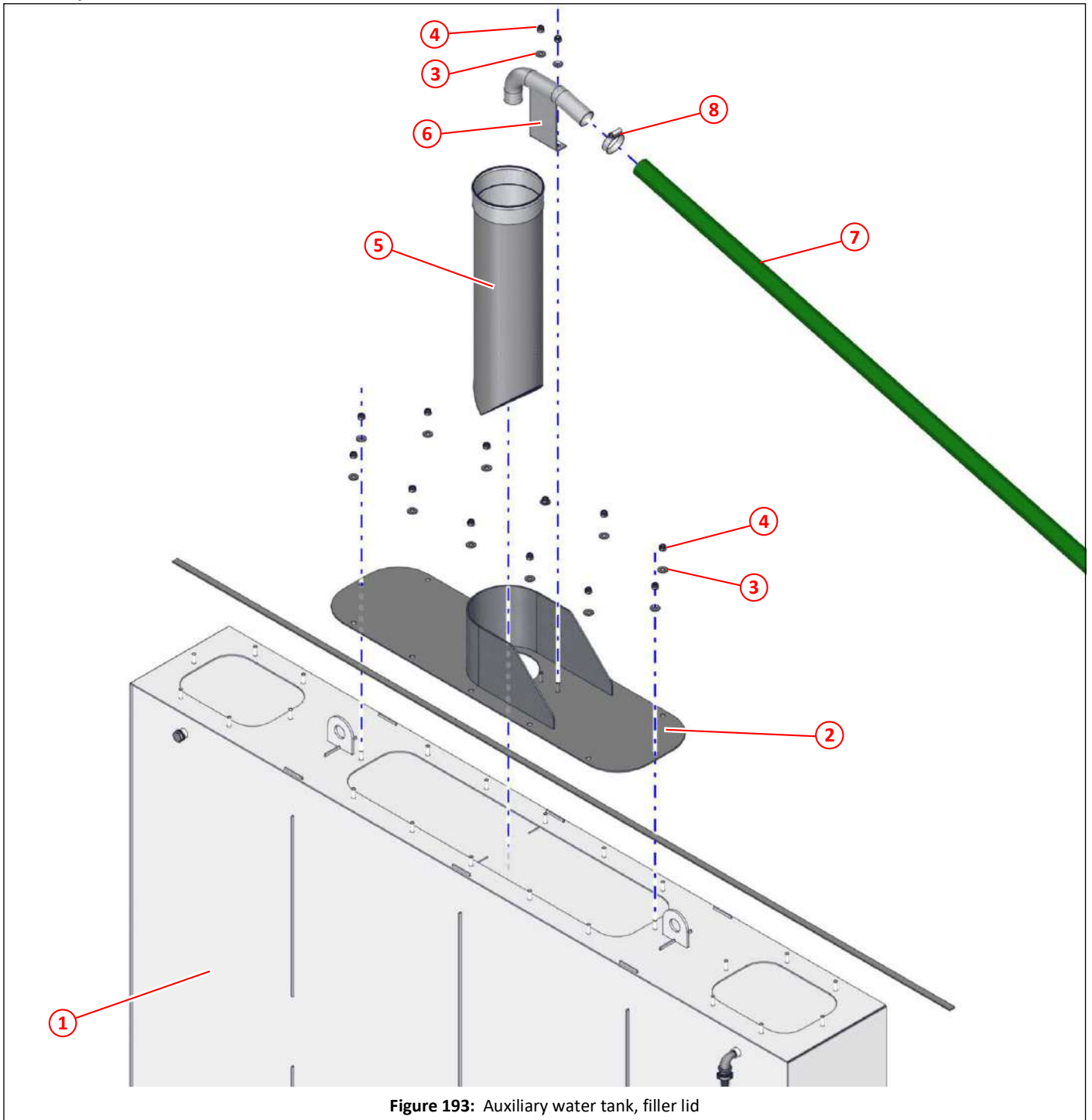

Figure 193: Auxiliary water tank, filler lid

Item	Part No	Qty	Description
①	043104	1	Auxiliary water tank 650 litre (US 172 gallons), no fittings
②	045151	1	Auxiliary water tank lid, centre
③	000264	14	Washer M8, stainless steel
④	000263	14	Nyloc nut T M8, stainless steel
⑤	032461	1	Water tank strainer
⑥	024586	1	Hydrant filler pipe
⑦	001045	1	Hose, green medium duty, $\phi 1\frac{1}{2}$ " , cut to required length
⑧	003007	1	Jubilee clip No. 2A [$\phi 35 - \phi 50$]
⑩	020362	2	Inseal strip 3 x 15, cut to 2250, placed under centre lid

Auxiliary water tank, water level sight tube

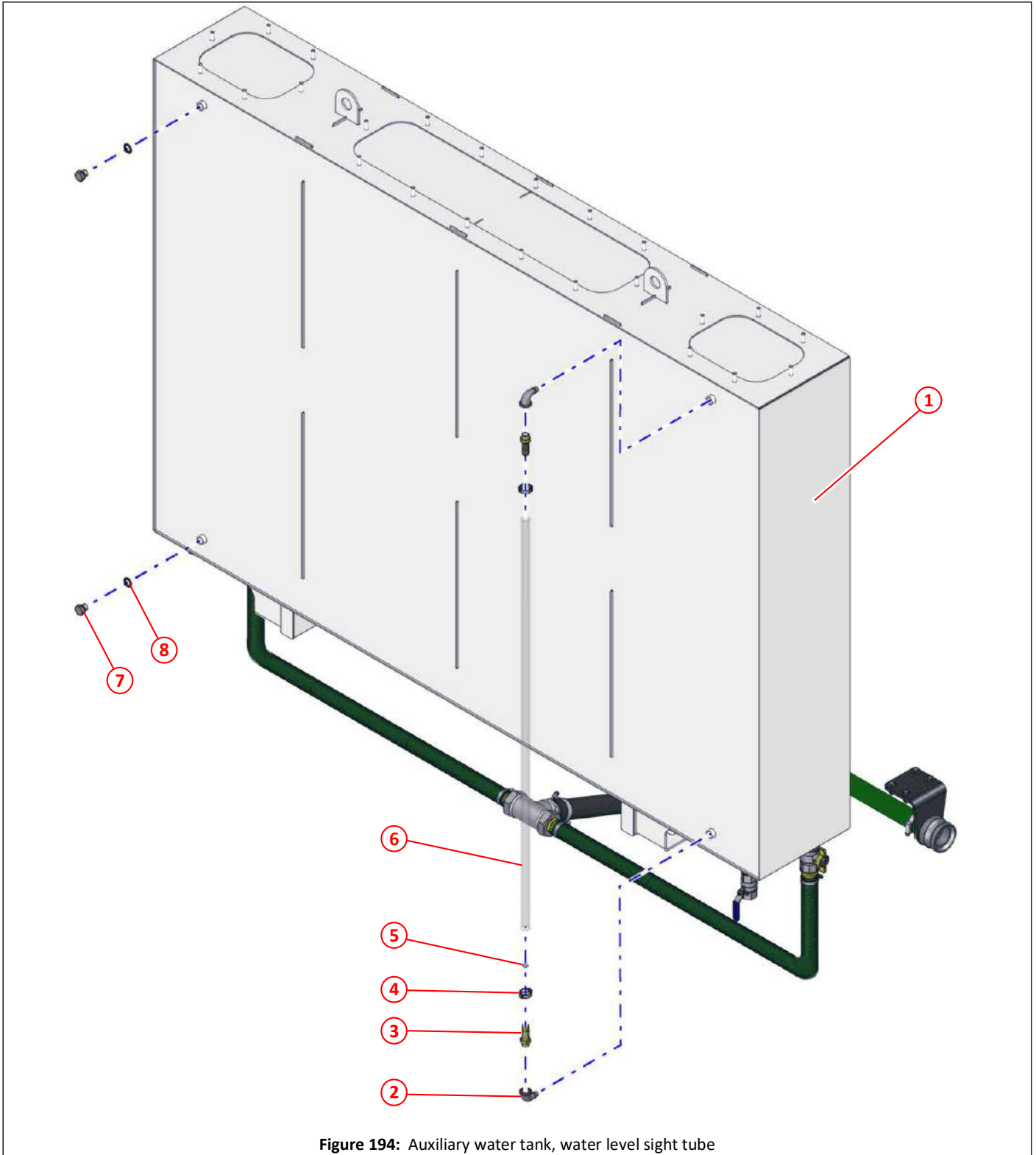

Figure 194: Auxiliary water tank, water level sight tube

Item	Part No	Qty	Description
①	043104	1	Auxiliary water tank 650 litre (US 172 gallons), no fittings
②	010913	2	Elbow, M/F, $\frac{3}{8}$ " BSP
③	010930	2	Adapter, $\frac{3}{8}$ " BSP x $\frac{5}{8}$ ", hose tail
④	000202	2	O-Clip $\frac{7}{8}$ "
⑤	025335	1	Ball, plastic, $\frac{1}{2}$ "
⑥	034465	1	PVC tube, clear, $\frac{5}{8}$ ", cut to 1500mm
⑦	011242	2	Plug, $\frac{3}{8}$ " BSP
⑧	011153	2	Dowty seal, $\frac{3}{8}$ " BSP

Auxiliary water tank, valve fittings

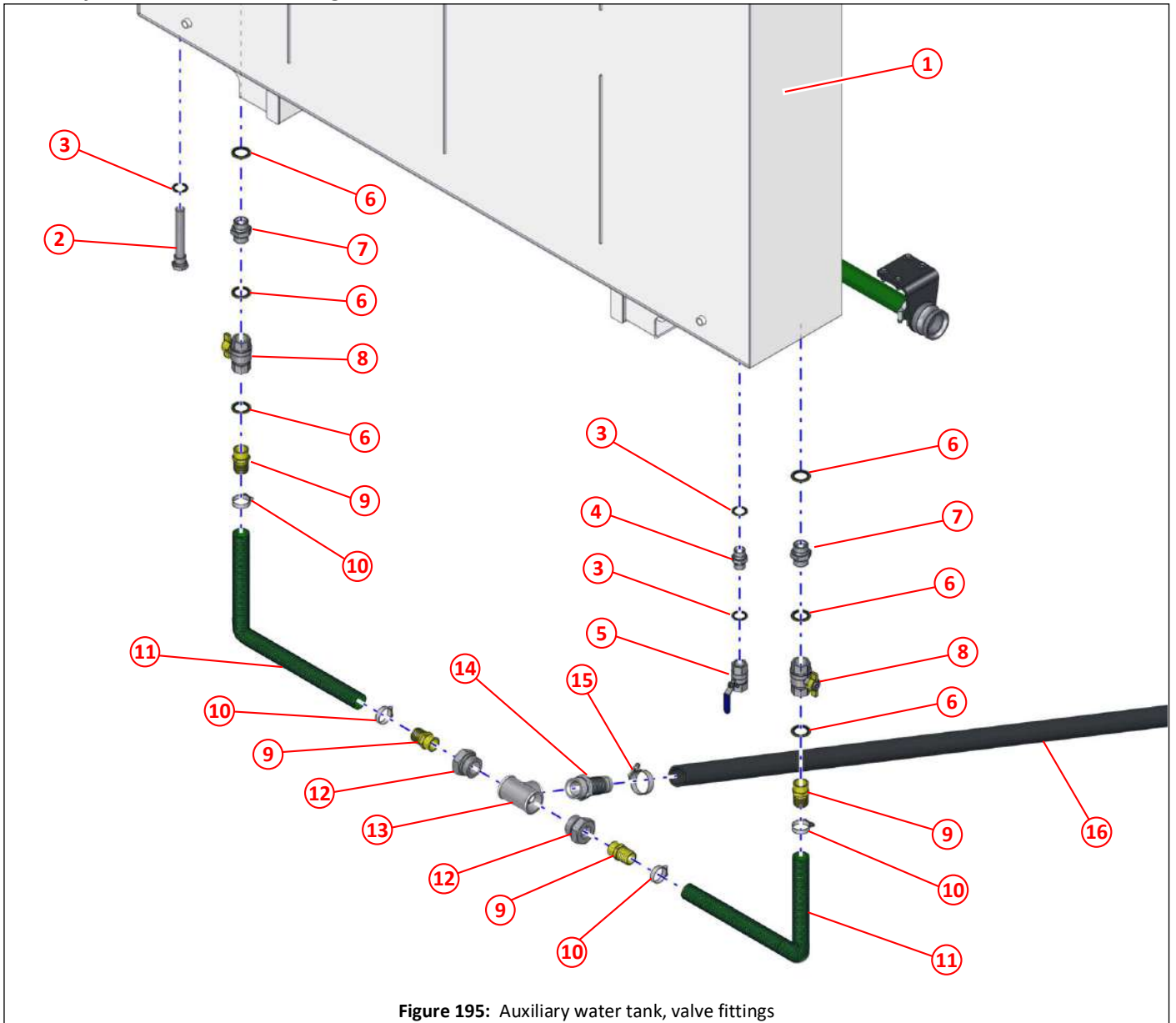

Figure 195: Auxiliary water tank, valve fittings

Item	Part No	Qty	Description
①	043104	1	Auxiliary water tank 650 litre (US 172 gallons), no fittings
②	012883	1	Sacrificial anode
③	011155	3	Dowty seal, $\frac{3}{4}$ " BSP
④	011161	1	Adapter, $\frac{3}{4}$ " BSP
⑤	013757	1	Valve , ball, $\frac{3}{4}$ " BSP, to drain tank
⑥	011156	6	Dowty seal, 1" BSP
⑦	011162	2	Adapter, 1" BSP
⑧	002050	2	Valve, ball 1" BSP, (low pressure) BVLP-16
⑨	003029	4	Adapter, 1" BSP x $1\frac{1}{4}$ " hose tail
⑩	003007	6	Jubilee clip 2A [ø35 - ø50]
⑪	001077	2	Hose, green medium duty ø1 $\frac{1}{4}$ ", cut to length required
⑫	003030	2	Reducer, $1\frac{1}{2}$ " x 1"
⑬	003043	1	Tee, $1\frac{1}{2}$ " BSP
⑭	002051	1	Adapter, $1\frac{1}{2}$ " BSP, male x $1\frac{1}{2}$ " hose tail
⑮	005081	1	Jubilee clip, high torque, size 50 [ø30 - ø50]
⑯	045968	2	Hose, SD MEGAFLEX, ø1 $\frac{1}{2}$ " ø38mm, cut to required length, to main water tank

Auxiliary water tank, hydrant filler fittings

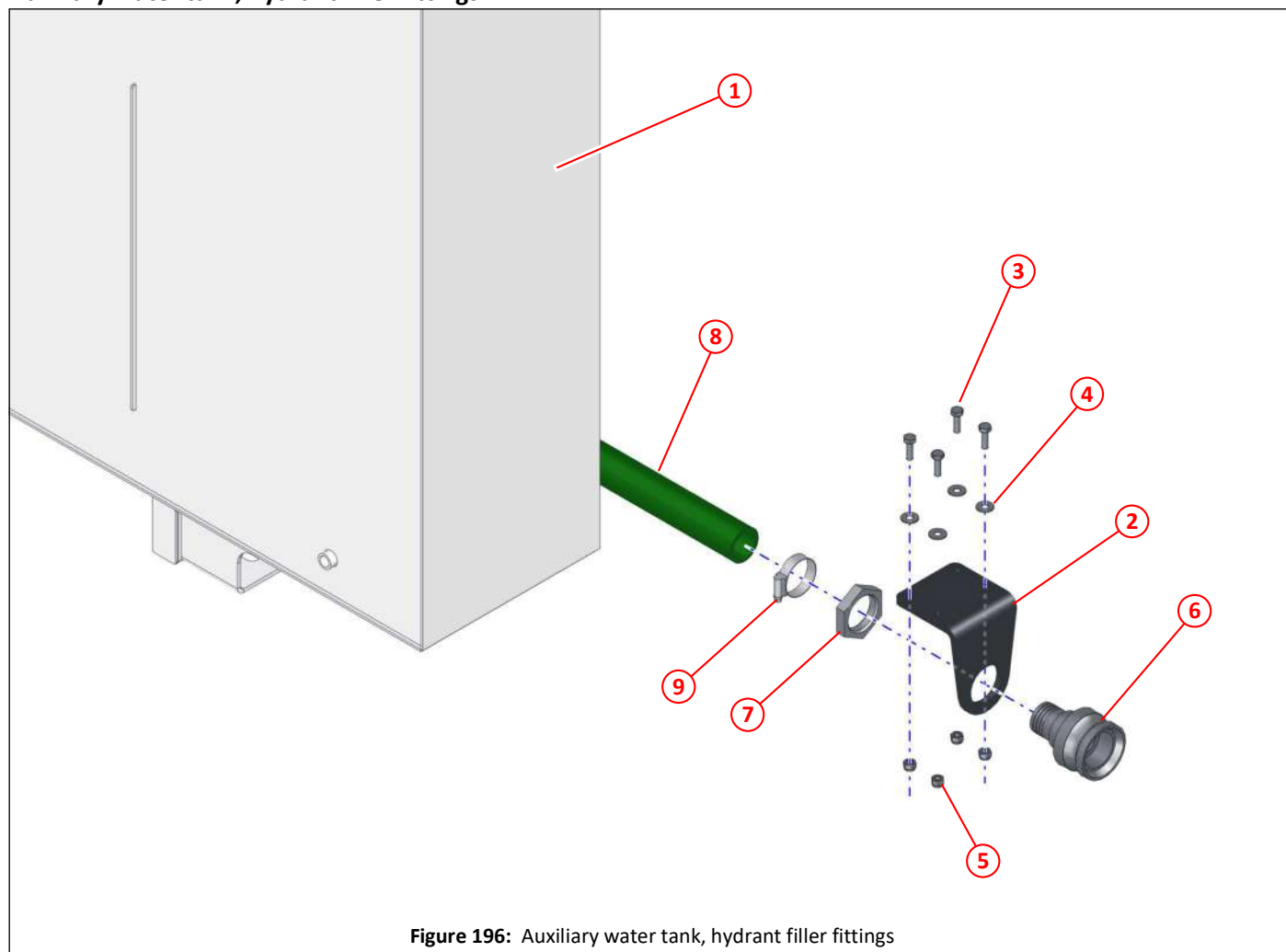

Figure 196: Auxiliary water tank, hydrant filler fittings

Item	Part No	Qty	Description
①	043104	1	Auxiliary water tank 650 litre (US 172 gallons), no fittings
②	039313	1	Adapter bracket, hydrant adapter
③	000257	4	Setscrew M8 x 25, stainless steel
④	000264	4	Washer M8, stainless steel
⑤	000263	4	Nyloc nut T M8, stainless steel
⑥	025140	1	Hydrant adapter
⑦	003026	1	Back nut 1½" BSP
⑧	001045	1	Hose, green medium duty, ø1½", cut to required length
⑨	003007	1	Jubilee clip No. 2A [ø35 - ø50]

Water strainer and fittings

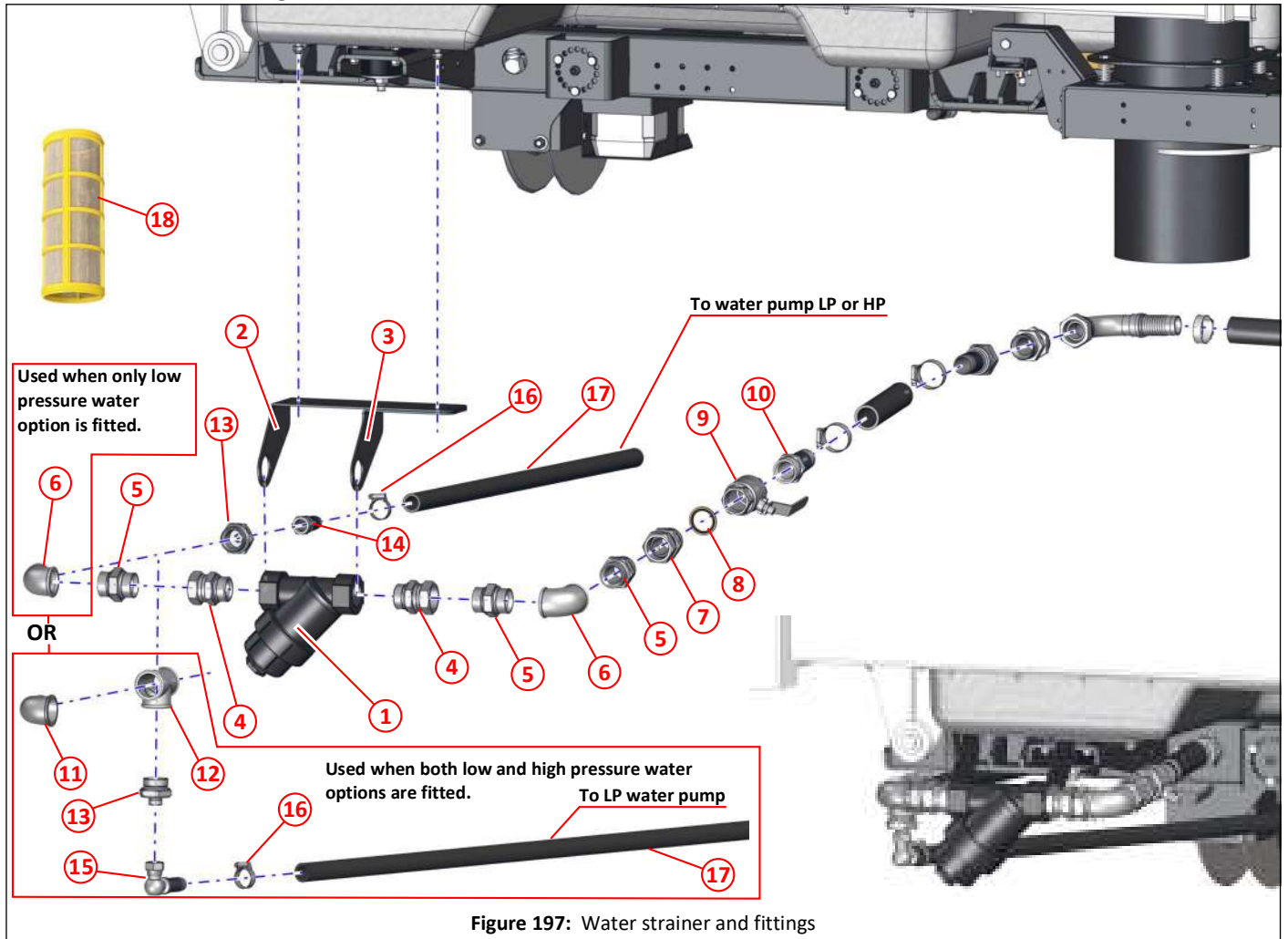

Figure 197: Water strainer and fittings

Item	Part No	Qty	Description
①	047422	1	Water strainer, 1½" BSP, complete with strainer element
②	047426	1	Water filter bracket 1
③	047427	1	Water filter bracket 2
④	002066	2	Adapter, male/female, 1½" BSP
⑤	002067	3	Adapter, 1½" BSP
⑥	003044	1	Elbow, female/female, 1½" BSP
⑦	047438	1	Air purge fitting, male/female, 1½" BSP
⑧	002072	1	Dowty seal, 1½" BSP
⑨	002065	1	Valve, ball, 1½" BSP, low pressure
⑩	002051	1	Adapter, straight, 1½" BSP x 1½" hose tail
⑪	003015	1	Elbow, male/female, 1½" BSP
⑫	003043	1	Tee, female/female/female, 1½" BSP
⑬	002069	2	Adapter, 1½" BSP x ¾" BSP
⑭	002084	1	Adapter, straight, ¾" BSPF x 1" hose tail
⑮	002203	1	Elbow, ¾" BSPP x 1" hose tail
⑯	010518	2	Jubilee clip No. 1X [ø30 - ø40]
⑰	010959	2	Hose 1", fuel, cut to required length
⑱	047423	1	Strainer element for item ①

Water strainer, water tank attachment fittings

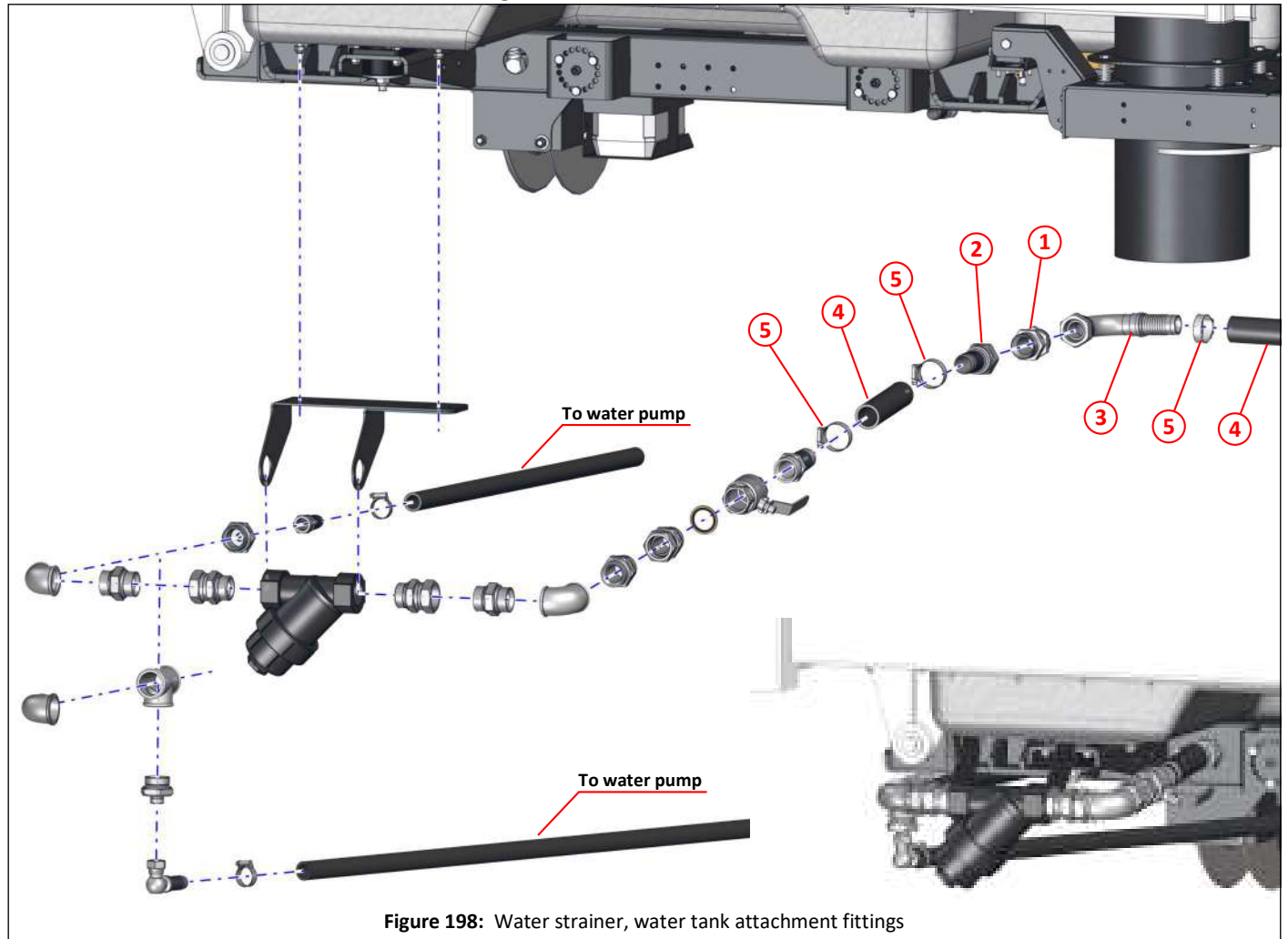

Figure 198: Water strainer, water tank attachment fittings

Item	Part No	Qty	Description
①	002285	1	Adapter, bulkhead, 1 1/2" BSP, with nut
②	002288	1	Adapter, straight, 1 1/2" BSP x 1 1/2" hose tail
③	002287	1	Elbow, 90° female 1 1/2" BSP x 1 1/2" hose tail
④	045968	2	Hose, SD MEGAFLEX, ø1 1/2" ø38mm, cut to required length
⑤	005081	3	Jubilee clip, high torque, size 50 [ø30 - ø50]

Low pressure water pump mounting

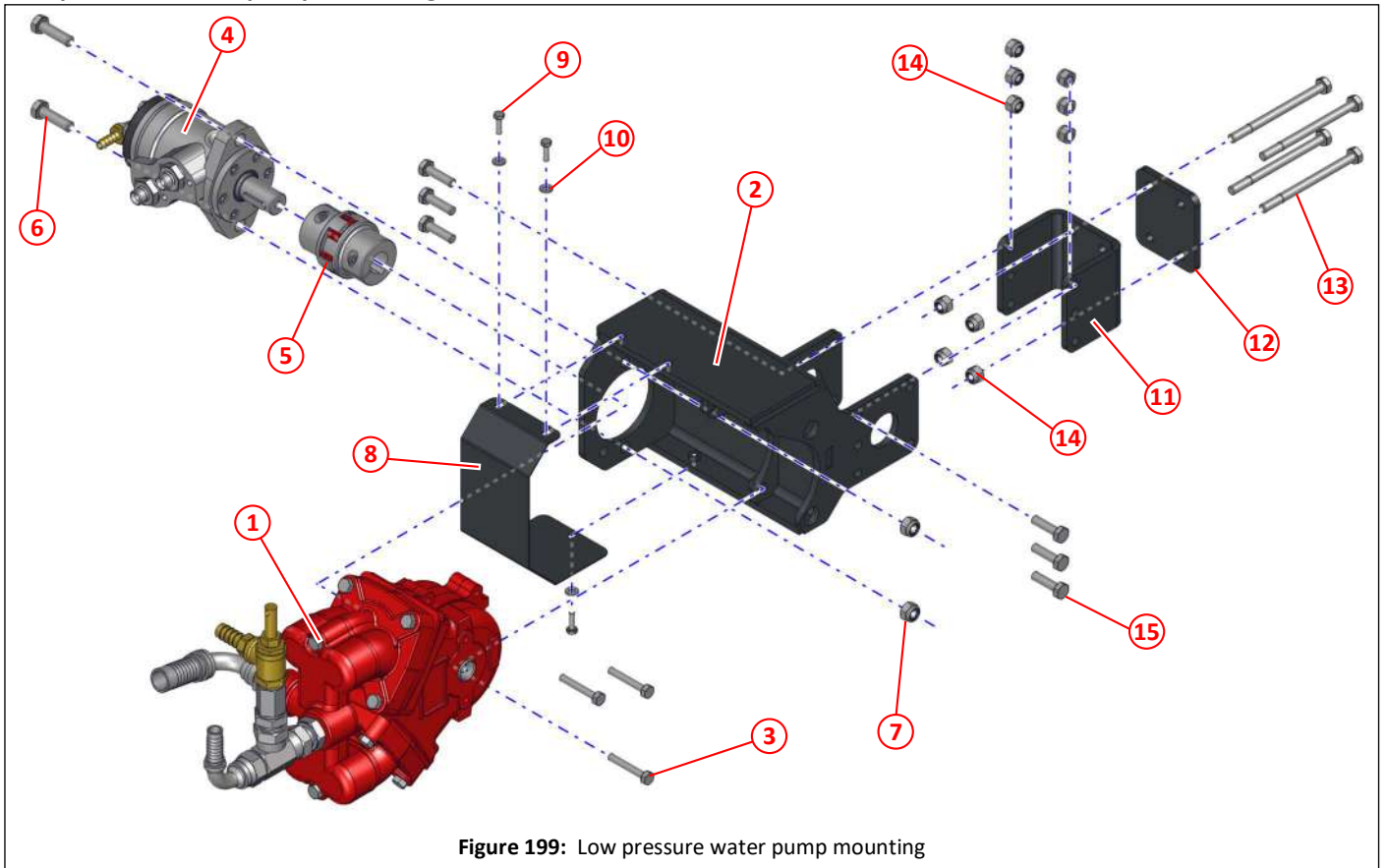

Figure 199: Low pressure water pump mounting

Item	Part No	Qty	Description
①	010208	1	Water pump, twin diaphragm, low pressure
②	045209	1	Mounting bracket, water pump, low pressure
③	011016	3	Setscrew HT M8 x 50
④	043778	1	Hydraulic motor, 40cc
⑤	043779	1	Coupling, water pump
⑥	011069	2	Bolt M12 x 40
⑦	011077	2	Nyloc nut T M12
⑧	044186	1	Cover, coupling
⑨	011067	3	Setscrew HT M6 x 20
⑩	011090	3	Washer M6
⑪	045030	1	Adapter plate, water pump mounting
⑫	045031	1	Spreader plate, water pump mounting
⑬	000075	4	Bolt HT M10 x 130
⑭	011075	10	Nyloc nut T M10
⑮	011033	6	Setscrew HT M10 x 35

Low pressure water pump fittings

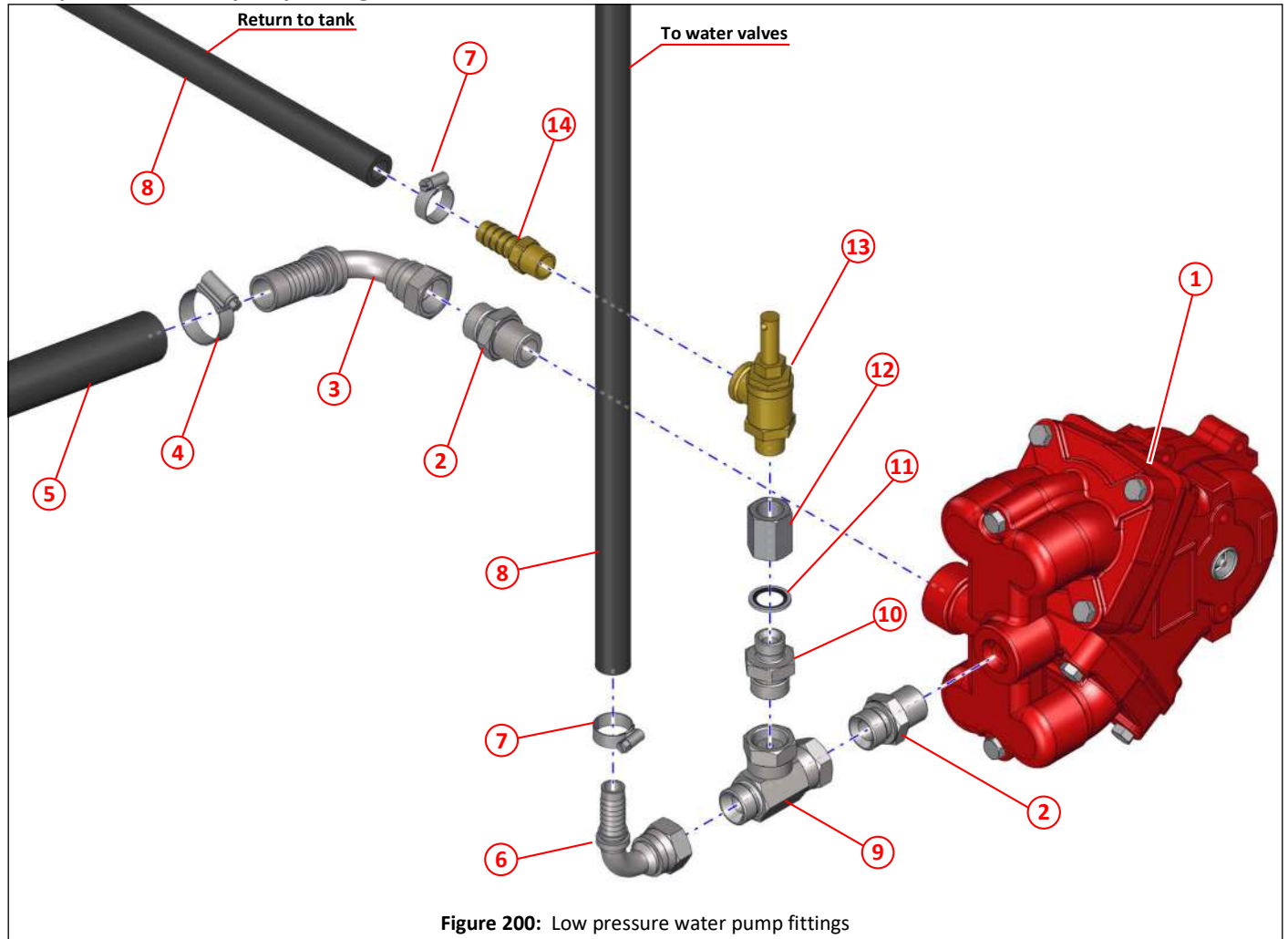

Figure 200: Low pressure water pump fittings

Item	Part No	Qty	Description
①	010208	1	Water pump, twin diaphragm, low pressure
②	002245	2	Adapter, $\frac{3}{4}$ " BSPP X $\frac{3}{4}$ " BSP, male/male
③	002079	1	Elbow, $\frac{3}{4}$ " BSP x 1" hose tail
④	010518	1	Jubilee clip No. 1X [ø30 - ø40]
⑤	010959	1	Hose 1", fuel, cut to required length, feed from water strainer
⑥	001145	1	Elbow, 90° $\frac{3}{4}$ " BSP x $\frac{5}{8}$ " hose tail
⑦	010517	2	Jubilee clip, No. 0X [ø18 - ø25]
⑧	011000	2	Hose, $\frac{5}{8}$ ", fuel SAE100R6, cut to length required
⑨	002233	1	Tee, $\frac{3}{4}$ " BSP, male/female/female, nut on branch
⑩	011166	1	Adapter, $\frac{3}{4}$ " BSP x $\frac{1}{2}$ " BSP
⑪	011154	1	Dowty seal $\frac{1}{2}$ " BSP
⑫	010900	1	Socket $\frac{1}{2}$ " BSP
⑬	045532	1	Pressure regulating valve 3300 (13.8 BAR)
⑭	003042	1	Adapter, $\frac{1}{2}$ " BSPT male x $\frac{5}{8}$ " hose tail

Water pump, twin diaphragm, low pressure, components

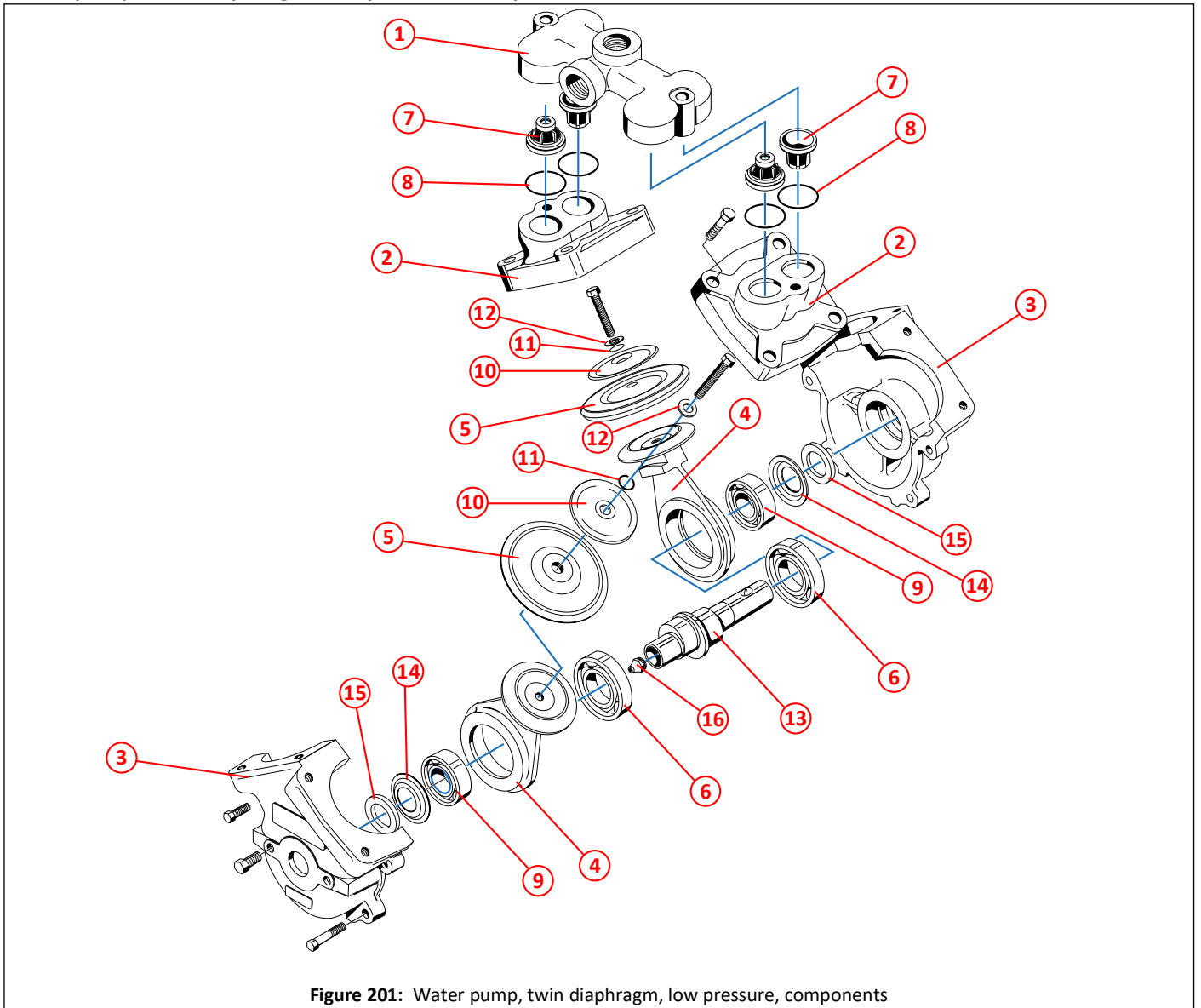

Figure 201: Water pump, twin diaphragm, low pressure, components

Item	Part No	Qty	Description
①	020460	1	Pump bridge, valve chamber
②	020463	2	Pump head, diaphragm cover
③	020461	2	Pump crankcase
④	014682	2	Connecting rod
⑤	013629	2	Diaphragm
⑥	013522	2	Bearing, ball
⑦	013627	4	Poppet valve
⑧	013628	4	Sealing ring
⑨	022726	2	Bearing, ball
⑩	014882	2	Diaphragm upper
⑪	031560	2	Seal
⑫	031561	2	Washer
⑬	048004	1	Pump eccentric
⑭	014881	2	Retainer
⑮	014879	2	Felt Washer
⑯	010903	1	Grease nipple, straight, $\frac{1}{8}$ " BSP

Water valves, low pressure, location

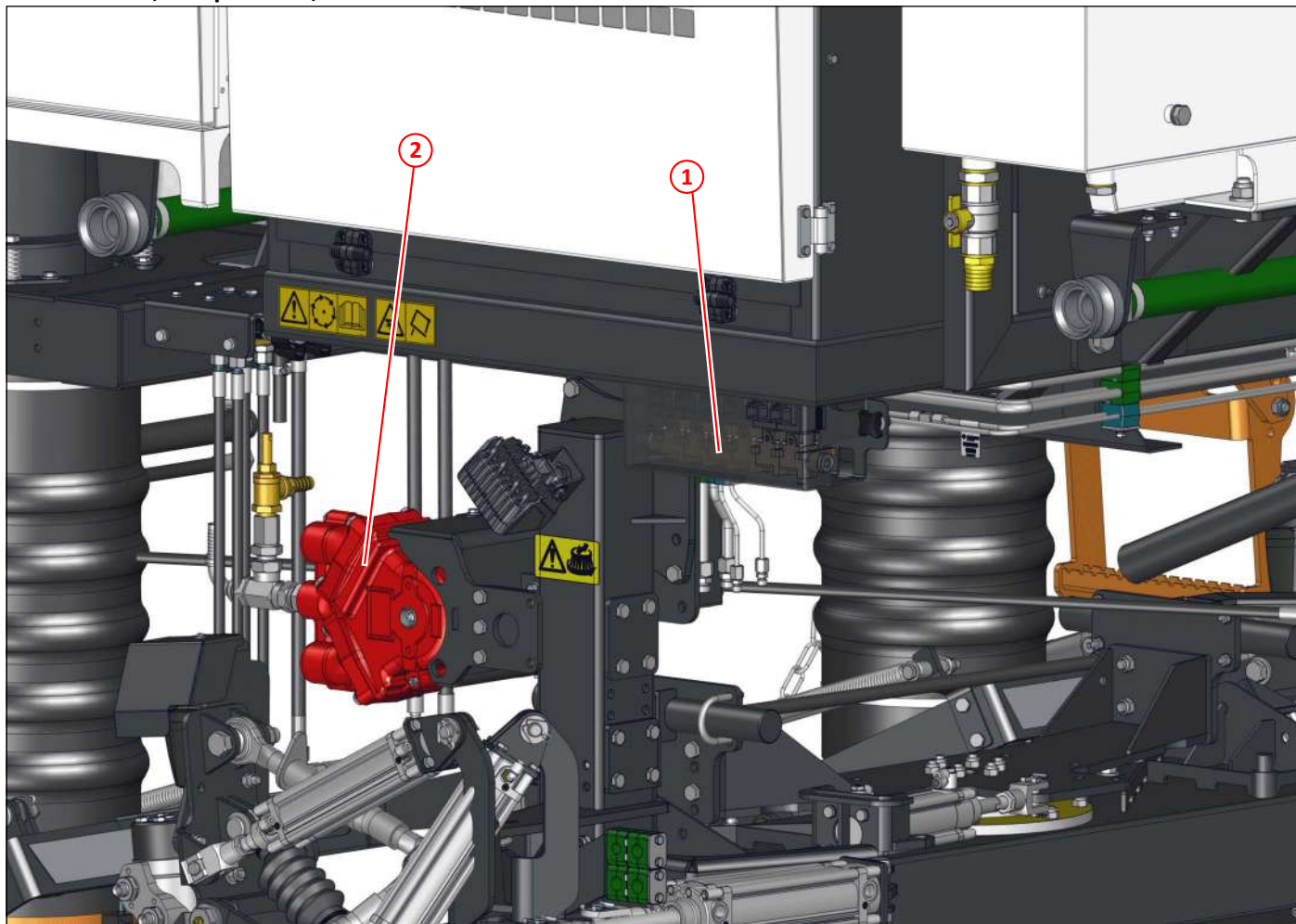

Figure 202: Water valves, low pressure, location

Item	Part No	Qty	Description	
①			Water valves, low pressure	237
②	010208	1	Water pump, twin diaphragm, low pressure	234

Water valves, low pressure, assemblies

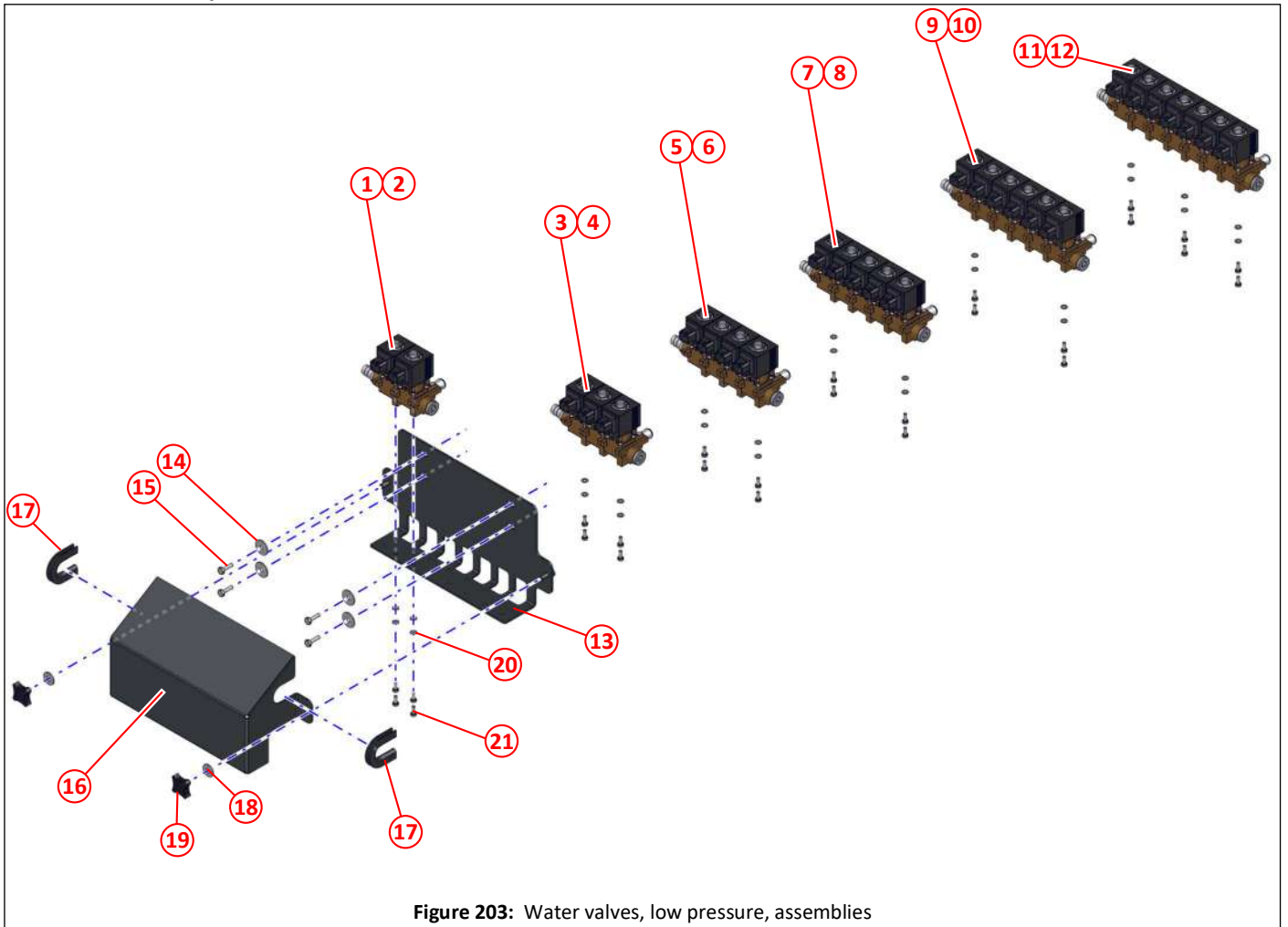
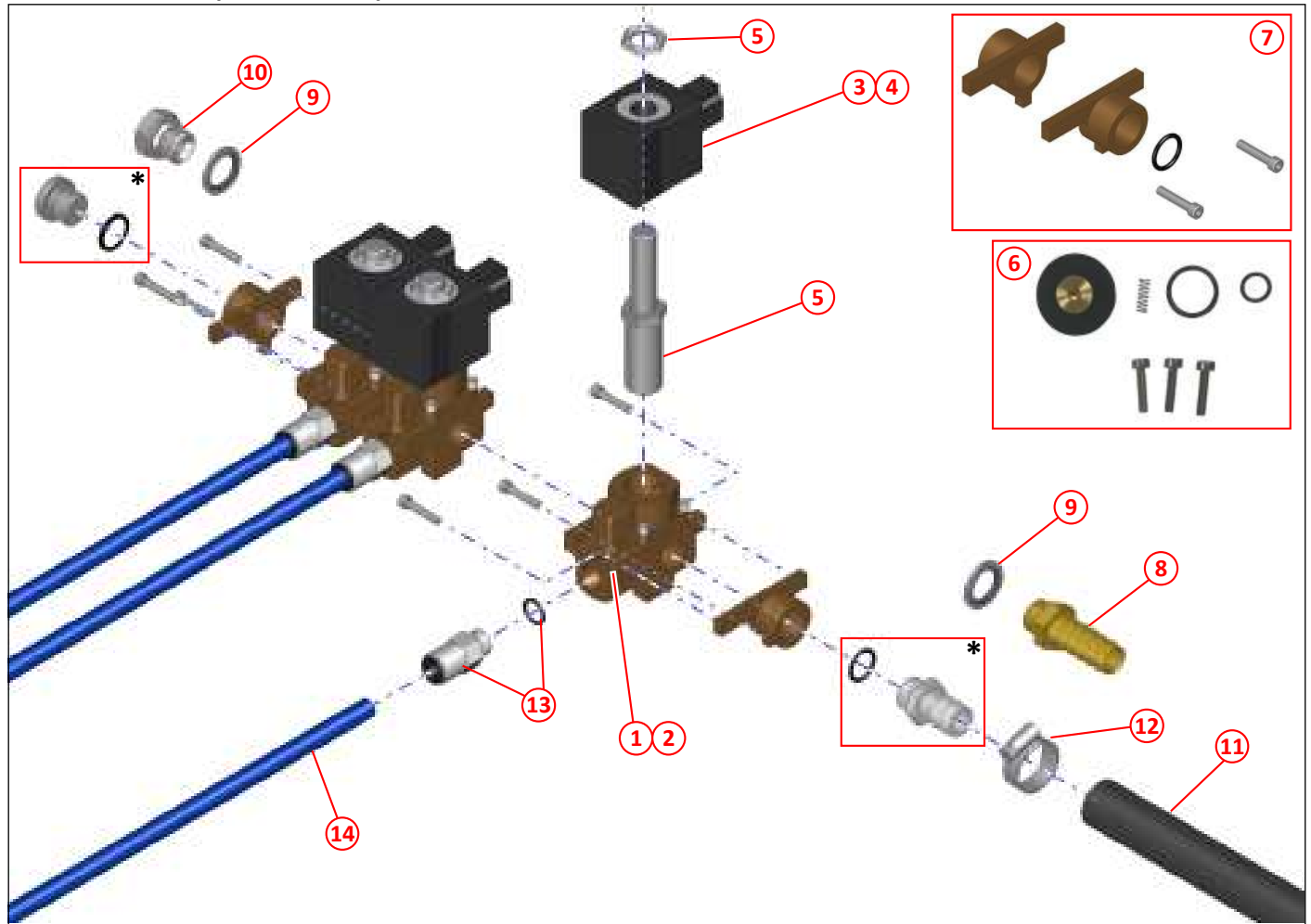

Figure 203: Water valves, low pressure, assemblies

Item	Part No	Qty	Description
①	047704	1	2 valve, water valve assembly - 12V
②	047692	1	2 valve, water valve assembly - 24V
③	047706	1	3 valve, water valve assembly - 12V
④	047694	1	3 valve, water valve assembly - 24V
⑤	047708	1	4 valve, water valve assembly - 12V
⑥	047696	1	4 valve, water valve assembly - 24V
⑦	047710	1	5 valve, water valve assembly - 12V
⑧	047698	1	5 valve, water valve assembly - 24V
⑨	047712	1	6 valve, water valve assembly - 12V
⑩	047700	1	6 valve, water valve assembly - 24V
⑪	047714	1	7 valve, water valve assembly - 12V
⑫	047702	1	7 valve, water valve assembly - 24V
⑬	043365	1	Water valve mount, low pressure
⑭	011099	4	Repair washer $\phi\frac{1}{4}$ x $\phi 1$ "
⑮	011067	4	Setscrew HT M6 x 20
⑯	043366	1	Water valve cover, low pressure
⑰	005073	2	Safety edging, TITANFAST MET106, cut to required length
⑱	011092	2	Washer M8
⑲	000248	2	Grip nut M8
⑳	000410	4 or 6	Washer M5
㉑	000097	4 or 6	Bolt M5 x 12

Water valves, low pressure, components



i * These are the original fitment parts. See items ⑧, ⑨ and ⑩ for replacements.

Figure 204: Water valves, low pressure, components

Item	Part No	Qty	Description
①	038368	1	Water valve, includes items ③ and ⑤, 12V
②	037969	1	Water valve, includes items ④ and ⑤, 24V
③	038371	1	Coil 12V/8W, Deutsch connector, 12V
④	037059	1	Coil 24V/8W, Deutsch connector, 24V
⑤	034625	1	Solenoid valve, includes nut
⑥	034624	1	Service repair kit, water valve
⑦	045753	1	Service kit, water valve
⑧	010930	1	Adapter $\frac{3}{8}$ " BSP x $\frac{5}{8}$ " hose tail
⑨	011153	2	Dowty seal $\frac{3}{8}$ " BSP
⑩	011242	1	Plug $\frac{3}{8}$ " BSP
⑪	011000	1	Hose, $\frac{5}{8}$ " , fuel SAE100R6, cut to length required, from water pump
⑫	010517	1	Jubilee clip, No. 0X [ø18 - ø25]
⑬	047715	1	Connector, push in, ø10mm x $\frac{1}{4}$ " BSP male
⑭	041031	1	Blue flexible nylon tubing, ø10mm, cut to length as required

Water spray nozzle, twin, side brushes

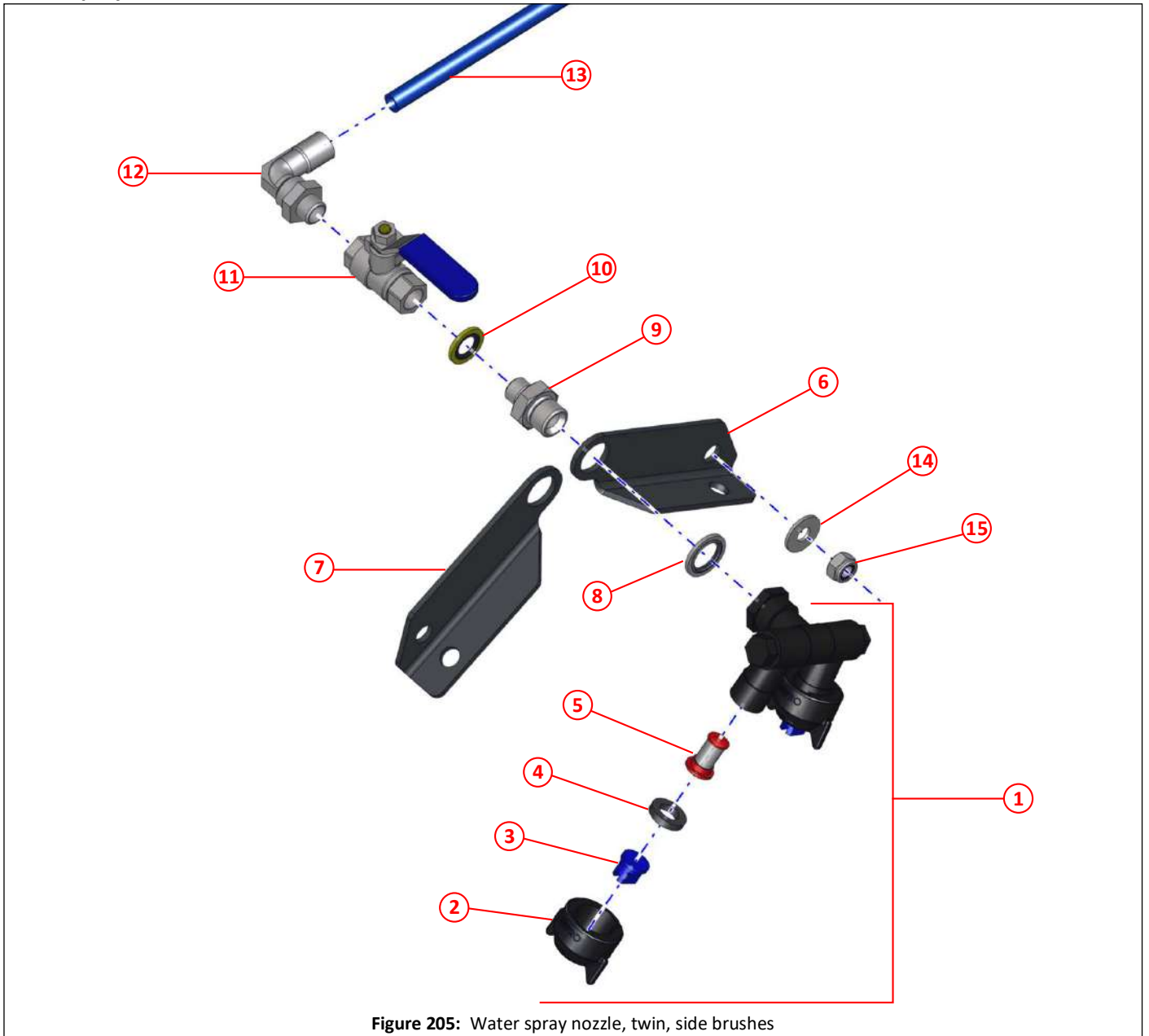

Figure 205: Water spray nozzle, twin, side brushes

Item	Part No	Qty	Description
①	036044	1	Double swivel nozzle assembly
②	030746	1	Nozzle cap, cone, per nozzle
③	030748	1	Jet, blue, per nozzle
④	030636	1	Rubber washer, per nozzle
⑤	030633	1	Filter, 100 mesh, per nozzle
⑥	036042	1	Nozzle bracket, for left hand side
⑦	036043	1	Nozzle bracket, for right hand side
⑧	011153	1	Dowty seal $\frac{3}{8}$ " BSP
⑨	011199	1	Adapter, $\frac{3}{8}$ " BSP x $\frac{1}{4}$ " BSP
⑩	011152	1	Dowty seal $\frac{1}{4}$ " BSP
⑪	011743	1	Valve, ball $\frac{1}{4}$ " BSP
⑫	047602	1	Elbow, push in, \varnothing 10mm x $\frac{1}{4}$ " BSP male
⑬	041031	1	Blue flexible nylon tubing, \varnothing 10mm, cut to length as required
⑭	011092	1	Washer M8
⑮	011073	1	Nyloc nut T M8

Water spray nozzles, suction nozzle

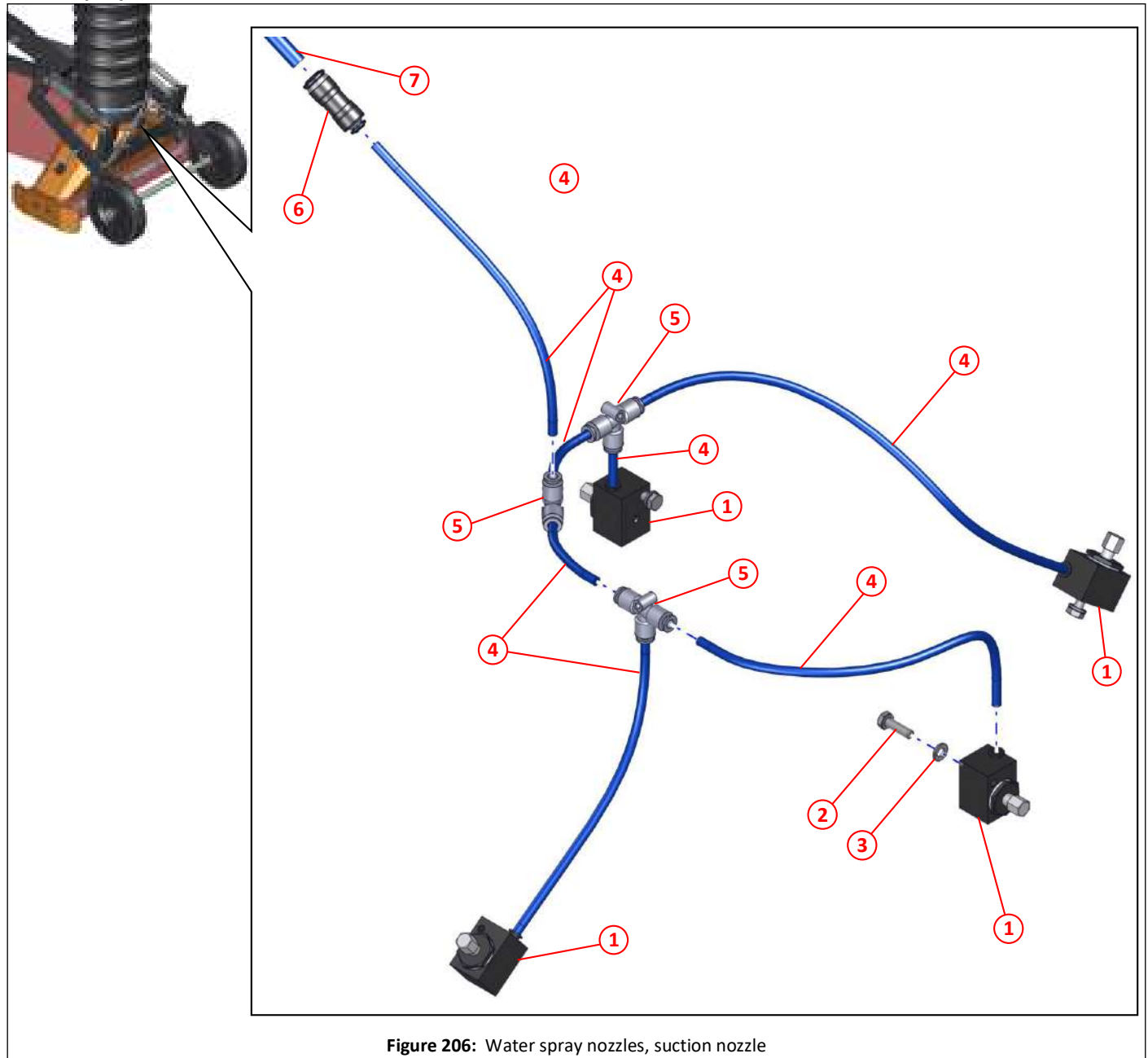

Figure 206: Water spray nozzles, suction nozzle

Item	Part No	Qty	Description
①	034342 *	4	Spray jet block
②	011067 *	4	Setscrew HT M6 x 20
③	011091 *	4	Spring washer M6
④	035733 *	7	Blue flexible nylon tubing, ø6mm, cut to length as required
⑤	024647 *	3	Tee, push in, ø6mm, grey
⑥	041029 *	1	Adapter, straight, push in, ø10mm to ø6mm
⑦	041031 *	1	Blue flexible nylon tubing, ø10mm, cut to length as required

*. Quantities shown are per suction nozzle.

Water spray nozzles, suction spigot

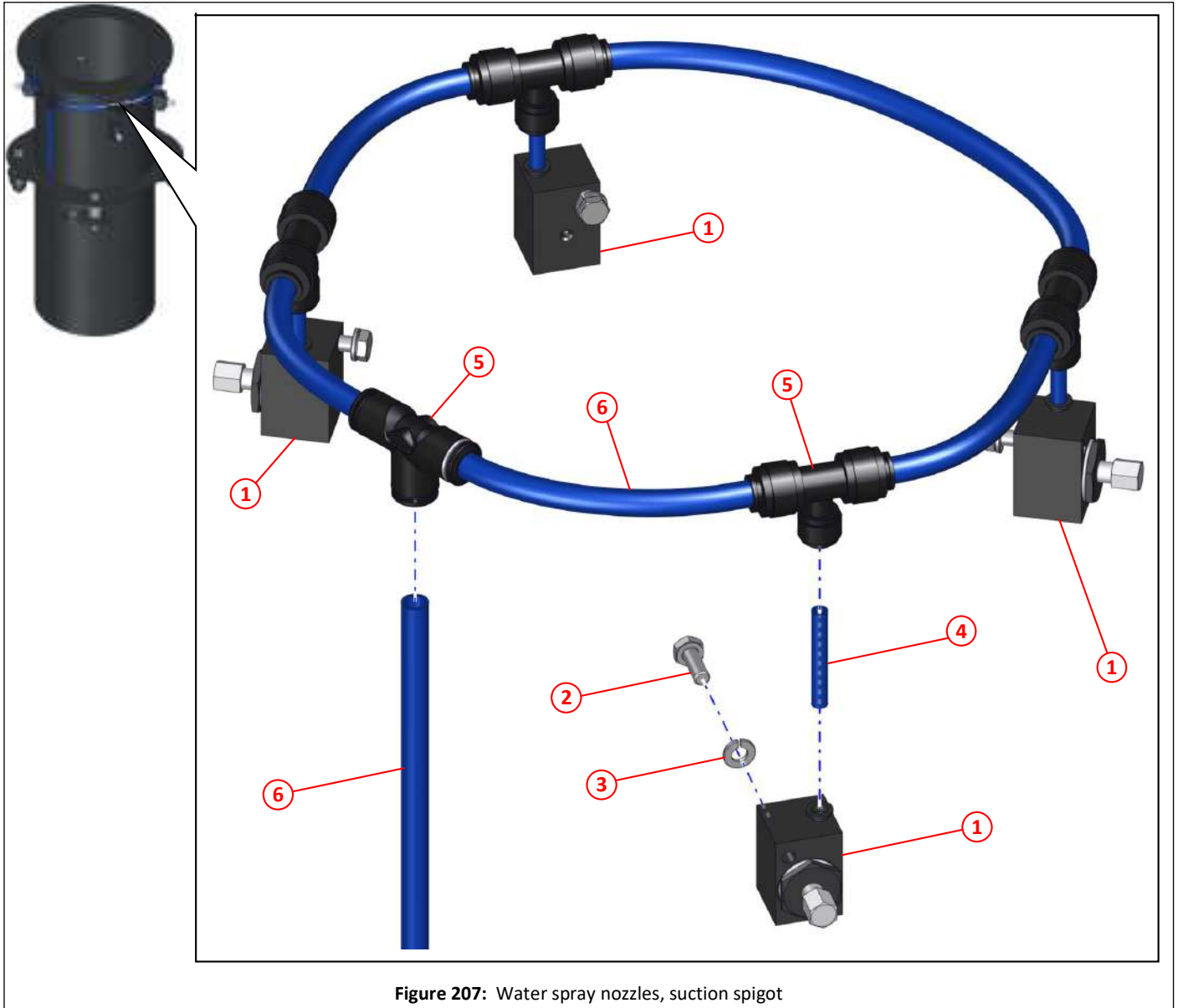

Figure 207: Water spray nozzles, suction spigot

Item	Part No	Qty	Description
①	034342 *	4	Spray jet block
②	011067 *	4	Setscrew HT M6 x 20
③	011091 *	4	Spring washer M6
④	035733 *	4	Blue flexible nylon tubing, ø6mm, cut to length as required
⑤	047778 *	5	Tee, push in, ø10 x ø10 x ø6, reducer on branch
⑥	041031 *	6	Blue flexible nylon tubing, ø10mm, cut to length as required

*. Quantities shown are per suction spigot.

Front spray bar, low pressure

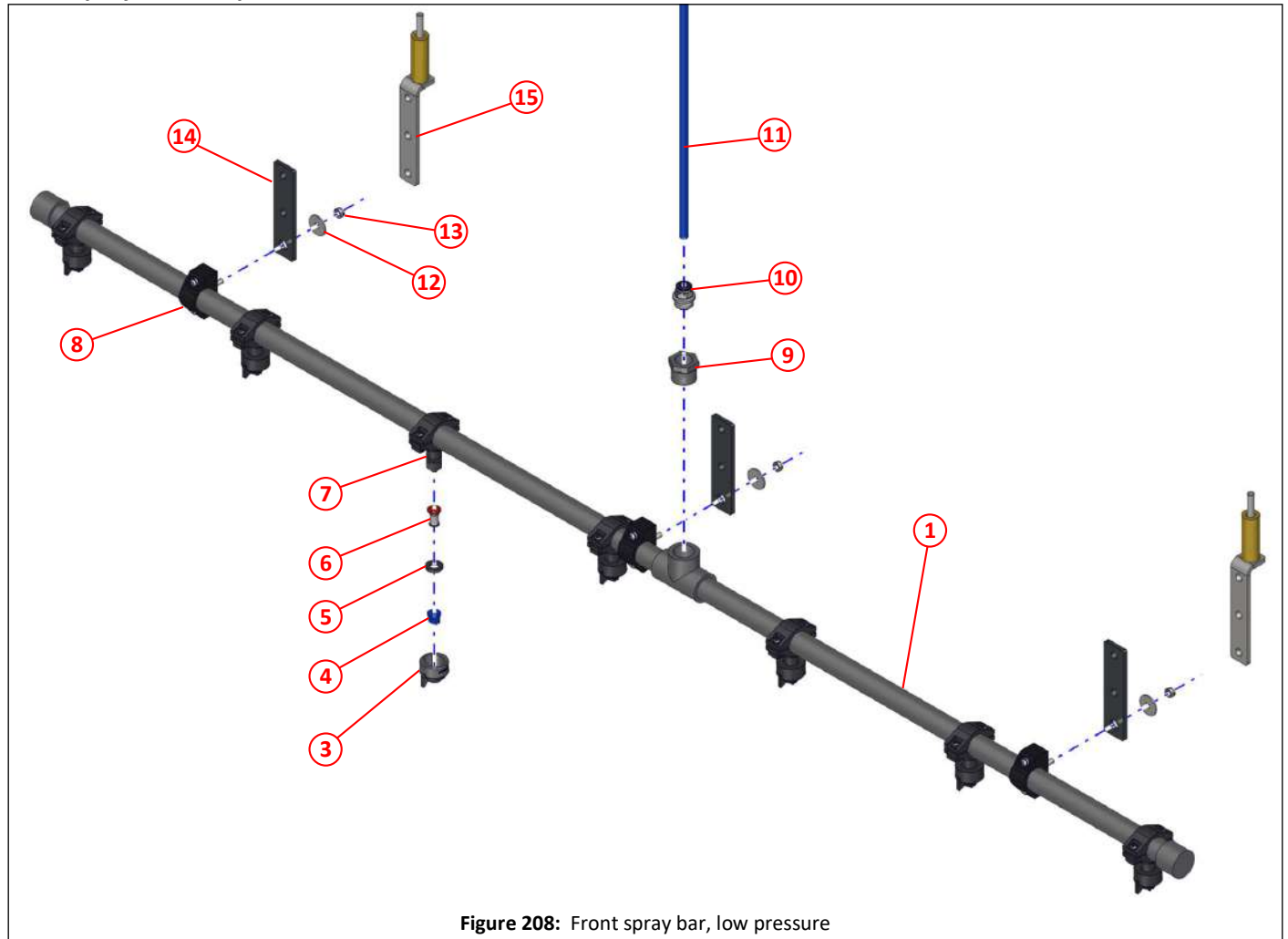

Figure 208: Front spray bar, low pressure

Item	Part No	Qty	Description
①	047716	1	Front spray bar, low pressure, includes items ③, ④, ⑤, ⑥, ⑦, and ⑧
②	047718	1	Front spray bar assembly, low pressure, includes items ①, ⑧, ⑨, and ⑩
③	030635 *	1	Nozzle cap, flat fan
④	030748 *	1	Jet, blue
⑤	030636 *	1	Rubber washer
⑥	030633 *	1	Filter, 100 mesh
⑦	030634 *	1	Nozzle holder
⑧	031338	1	Clamp
⑨	047717	1	Reducing bush, $\frac{3}{4}$ " to $\frac{1}{2}$ ", plastic
⑩	041028	1	Adapter, push in, $\frac{1}{2}$ " BSP to \varnothing 10mm
⑪	041031	6	Blue flexible nylon tubing, \varnothing 10mm, cut to length as required, from water valve
⑫	011099	1	Repair washer, $\varnothing\frac{1}{4}$ " x \varnothing 1"
⑬	011071	1	Nyloc nut T M6
⑭	030392 †	1	Bracket, spray bar
⑮	031921 †	1	Bracket, spray bar

*. Quantity per nozzle.

†. Examples of spray bar mounting brackets, contact Parts Department with chassis information.

Over head boom, dust suppression

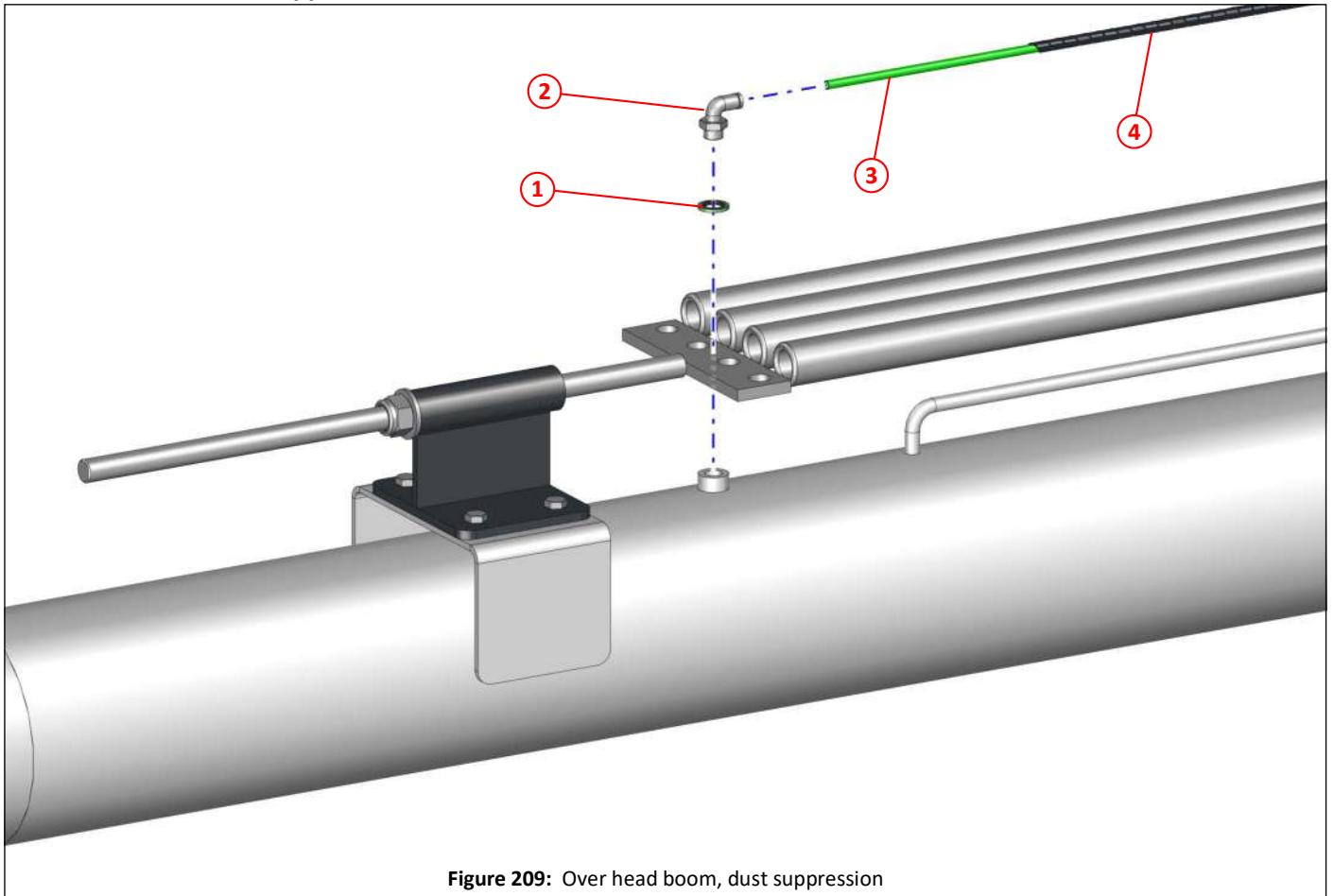

Figure 209: Over head boom, dust suppression

Item	Part No	Qty	Description	
①	011152	1	Dowty seal $\frac{1}{4}$ " BSP	
②	023203	1	Elbow, swivel, push in, $\phi 6 \times \frac{1}{4}$ " BSP	
③	024650	1	Green flexible nylon tubing, $\phi 6$ mm, cut to length as required	
④	004161	1	Flex cable conduit, split, $\phi 15.7$, cut to length as required	

High pressure water pump, mounting

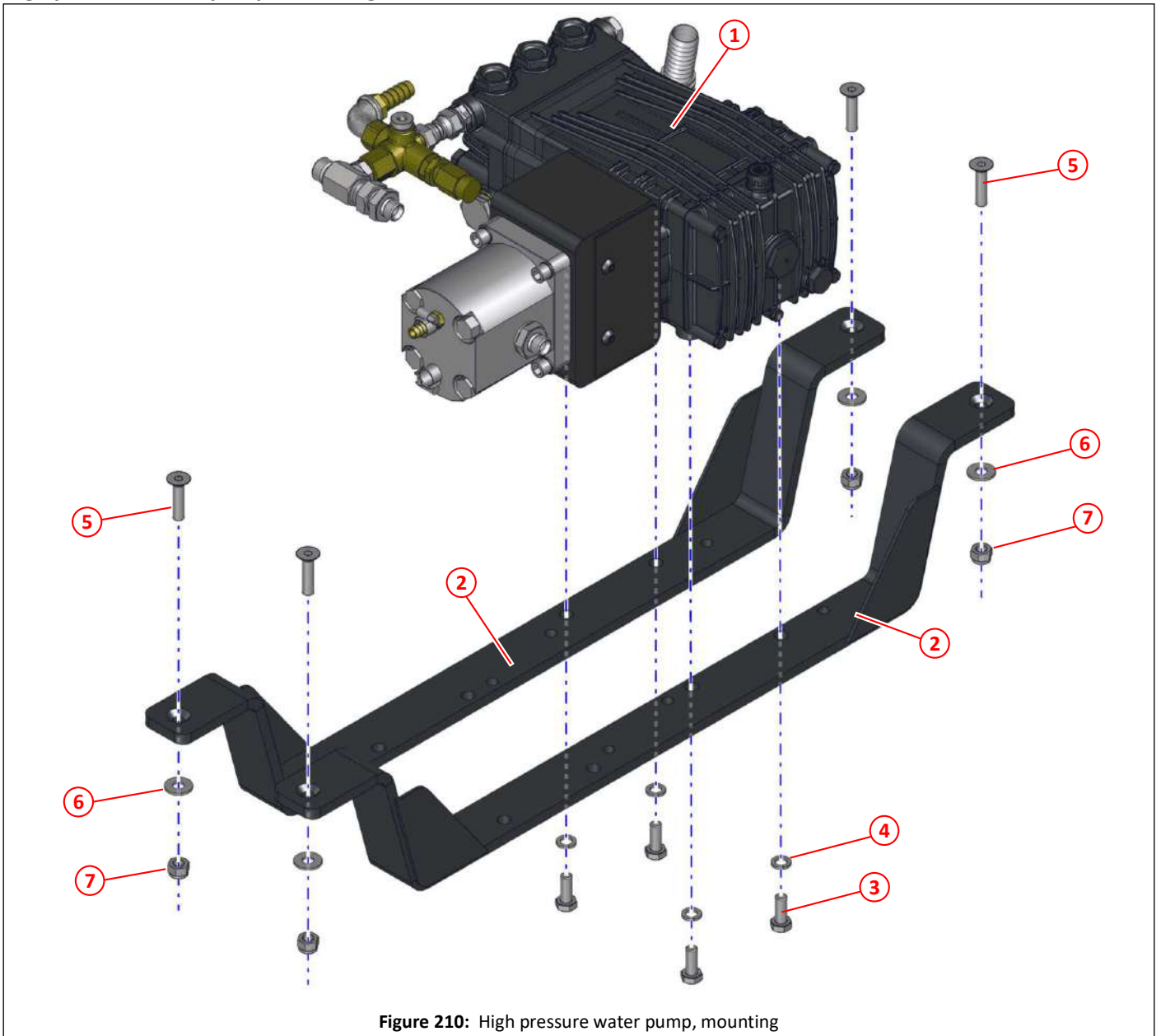

Figure 210: High pressure water pump, mounting

Item	Part No	Qty	Description	
①	047439	1	Water pump, 30 lpm, high pressure, assembly	245,246
②	022632	2	Pump support	
③	011031	4	Setscrew M10 x 25	
④	011095	4	Spring washer M10	
⑤	000167	4	Screw, countersunk M10 x 40	
⑥	011094	4	Washer M10	
⑦	011075	4	Nyloc nut T M10	

High pressure water pump, motor and fittings

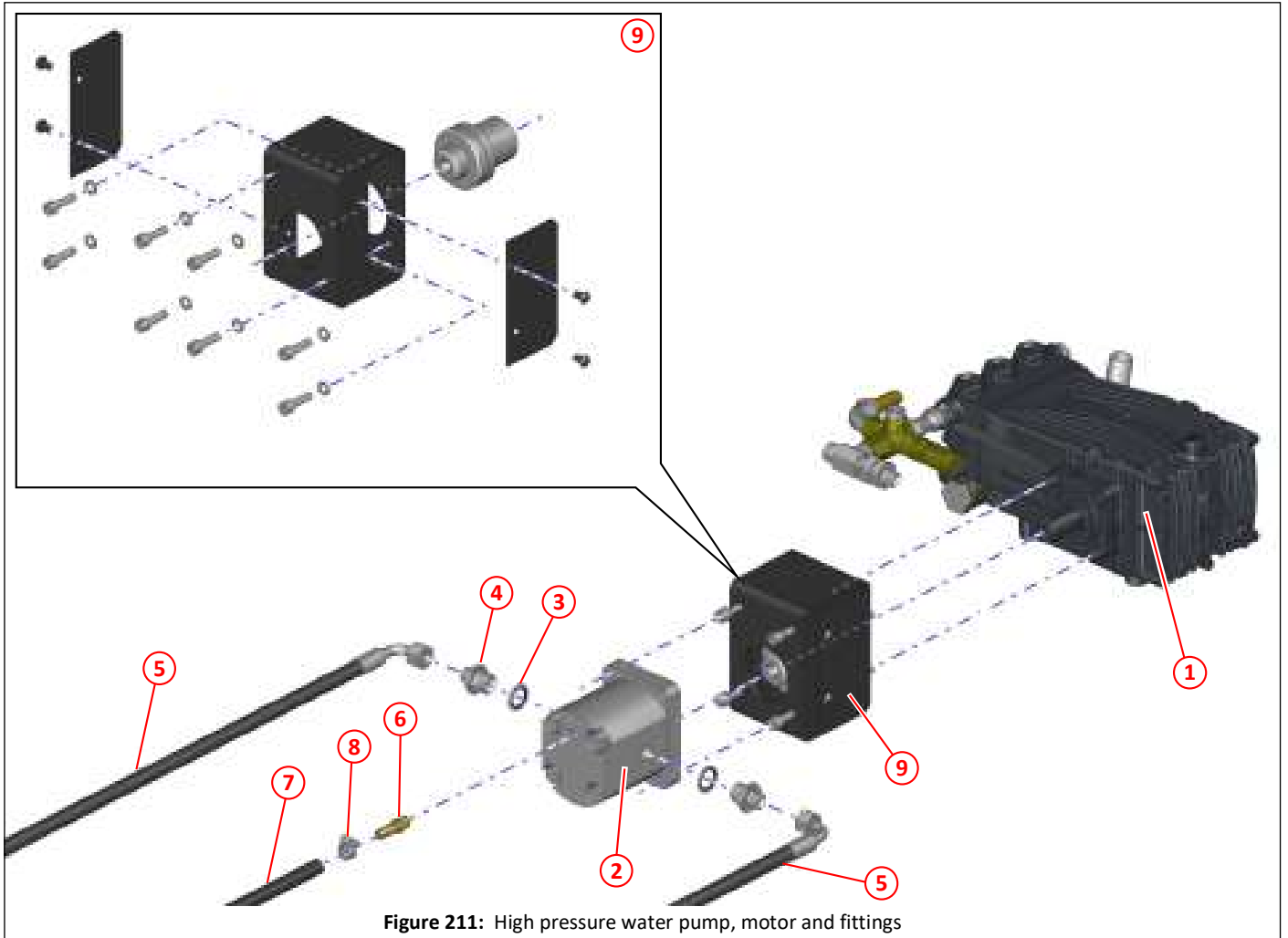

Figure 211: High pressure water pump, motor and fittings

Item	Part No	Qty	Description	
①	045366	1	Water pump (30 lpm), high pressure	244,246
②	025373	1	Motor, gear, 16cc, reversible	310
③	011154	2	Dowty seal $\frac{1}{2}$ " BSP	
④	011167	2	Adapter, $\frac{1}{2}$ " BSP x $\frac{3}{8}$ " BSP	
⑤	001149	2	Hose, $\frac{3}{8}$ " x 3550, straight and 90° connectors	
⑥	003010	1	Hosetail $\frac{1}{4}$ " BSPT x $\frac{3}{8}$ " hose	
⑦	010958	1	Hose $\frac{3}{8}$ ", cut to required length(s)	
⑧	003004	1	Jubilee clip, size 00 [ø13 - ø20]	
⑨	036654	1	Drive box kit, 30 lpm pump	

High pressure water pump, fittings and hoses

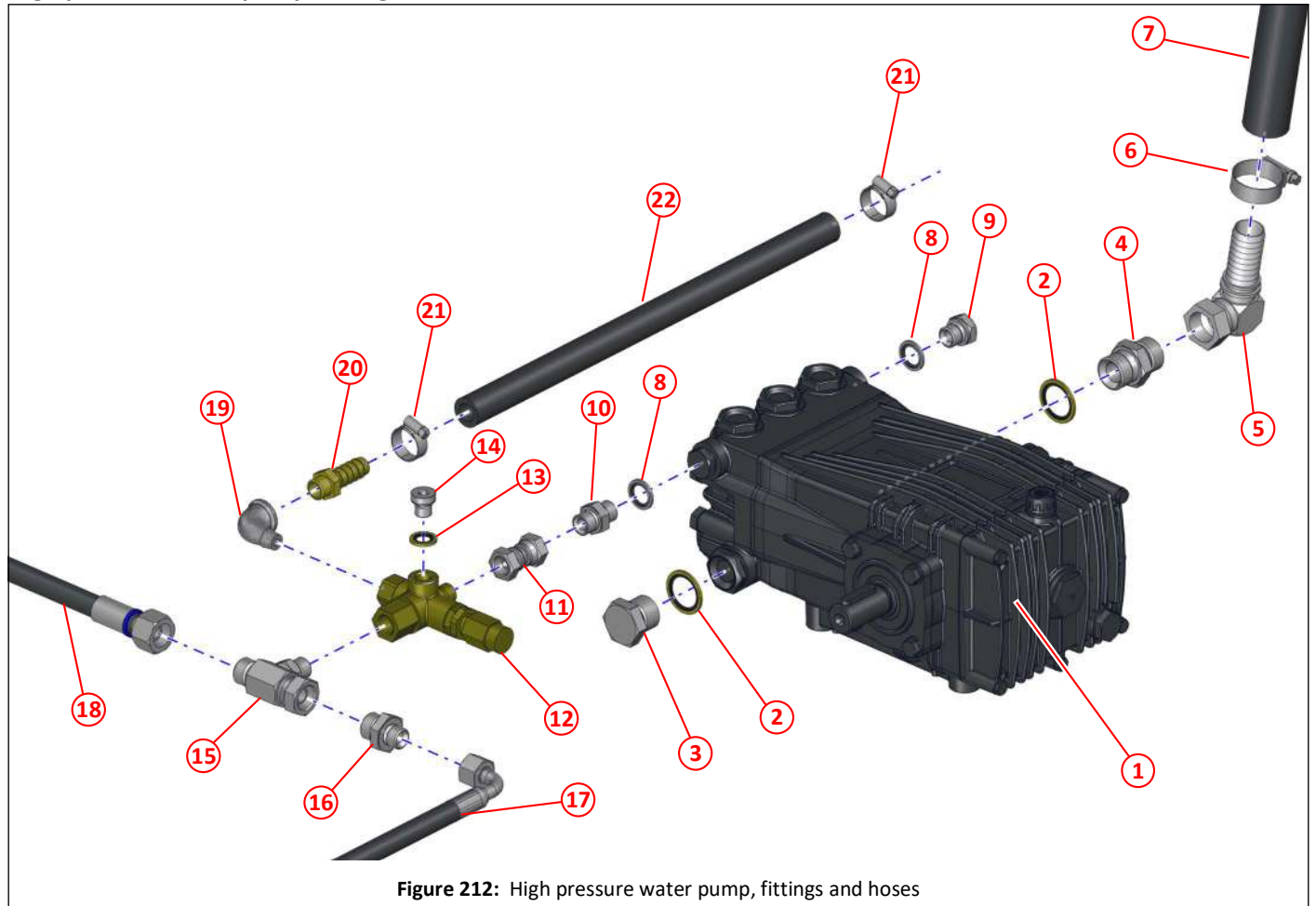

Figure 212: High pressure water pump, fittings and hoses

Item	Part No	Qty	Description	
①	045366	1	Water pump (30 lpm), high pressure	244,245
②	011155	2	Dowty seal $\frac{3}{4}$ " BSP	
③	011244	1	Plug, $\frac{3}{4}$ " BSP	
④	011161	1	Adapter, $\frac{3}{4}$ " BSP	
⑤	011210	1	Elbow, $\frac{3}{4}$ " BSPF x 1" hose tail	
⑥	005081	1	Jubilee clip, high torque, size 50 [ø30 - ø50]	
⑦	045968	1	Hose, SD MEGAFLEX, ø1½" ø38mm, cut to required length, feed from water filter	
⑧	011153	2	Dowty seal $\frac{3}{8}$ " BSP	
⑨	011242	1	Plug, $\frac{3}{8}$ " BSP	
⑩	011159	1	Adapter, $\frac{3}{8}$ " BSP	
⑪	011214	1	Adapter, $\frac{3}{8}$ " BSP, nut/nut	
⑫	010599	1	Valve, unloader, dual	
⑬	011152	1	Dowty seal $\frac{1}{4}$ " BSP	
⑭	002016	1	Plug, hex socket head, $\frac{1}{4}$ " BSP	
⑮	002110	1	Tee, $\frac{1}{2}$ " BSP male x $\frac{1}{2}$ " BSP female x $\frac{3}{8}$ " BSP male reducer on branch	
⑯	011167	1	Adapter, $\frac{1}{2}$ " BSP x $\frac{3}{8}$ " BSP	
⑰	001373	1	Hose, $\frac{3}{8}$ " x 900, straight and 90° connectors, feed to hose reel	
⑱	001370	1	Hose, $\frac{1}{2}$ " x 2430, straight and 90° connectors, feed to HP water valve manifold	
⑲	010913	1	Elbow, $\frac{3}{8}$ " BSP, male and female	
⑳	010930	1	Adapter $\frac{3}{8}$ " BSP x $\frac{5}{8}$ " hose tail	
㉑	010517	1	Jubilee clip, No OX [ø18 - ø25]	
㉒	011000	1	Hose, $\frac{5}{8}$ " , fuel SAE100R6, cut to length required, return to tank	

High pressure water pump 30lpm, seal and repair kits

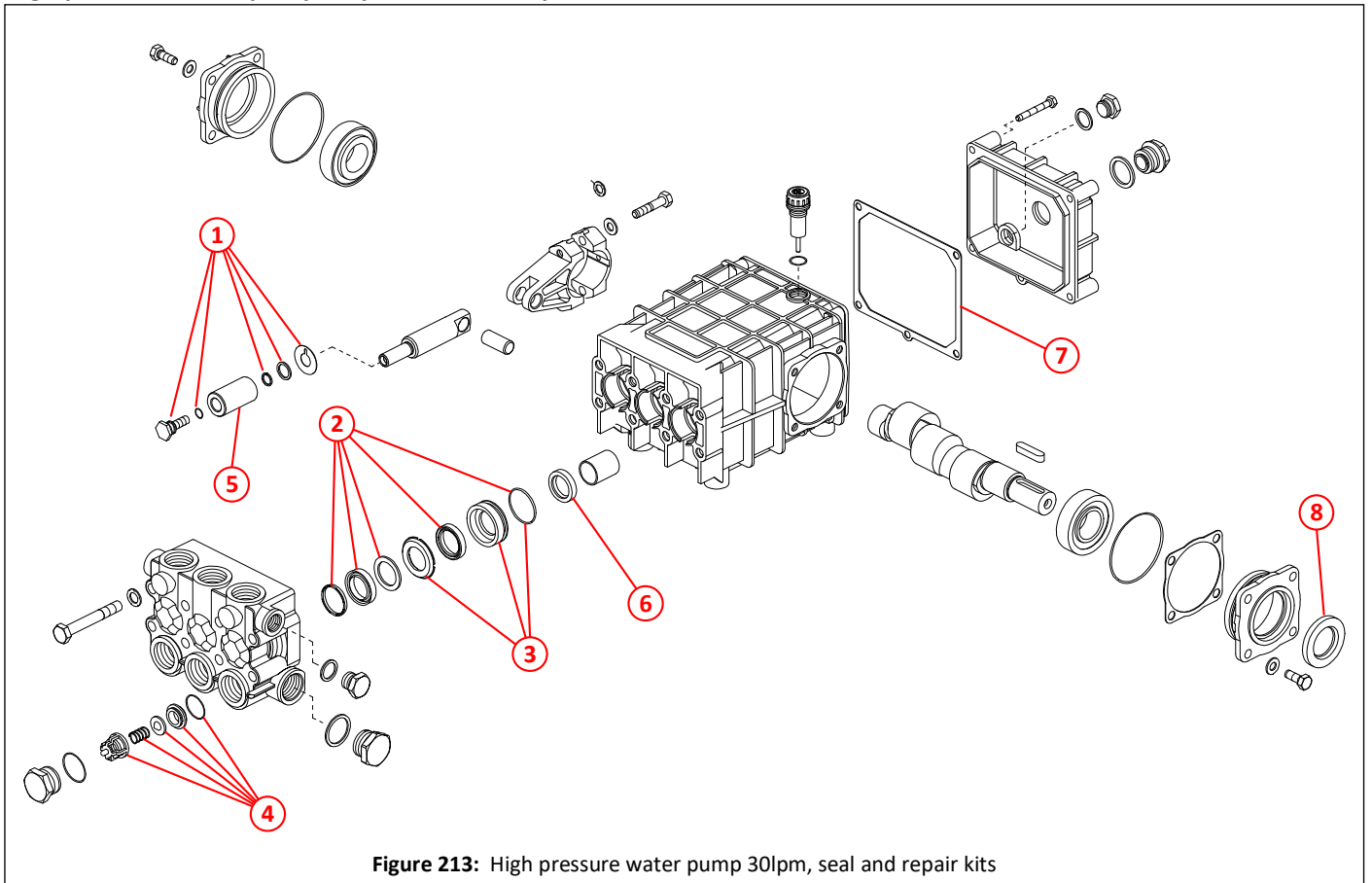

Figure 213: High pressure water pump 30lpm, seal and repair kits

Item	Part No	Qty	Description
①	045356	1	Piston bolt repair (Kit 6), PUCP 606106
②	045357	1	Water seal (Kit 11), PUWS 606111
③	045358	1	Brass insert (Kit 18), PUPB
④	045359	1	Valve (kit 3), PUVA 606103
⑤	045360	1	Ceramic piston, PUCP 120533
⑥	045361	1	Piston oil seal, PUOS 000743
⑦	045362	1	Crankcase cover gasket, PUGA 060275
⑧	045363	1	Shaft oil seal, PUOS 000738

Water manifold (HP) label plate

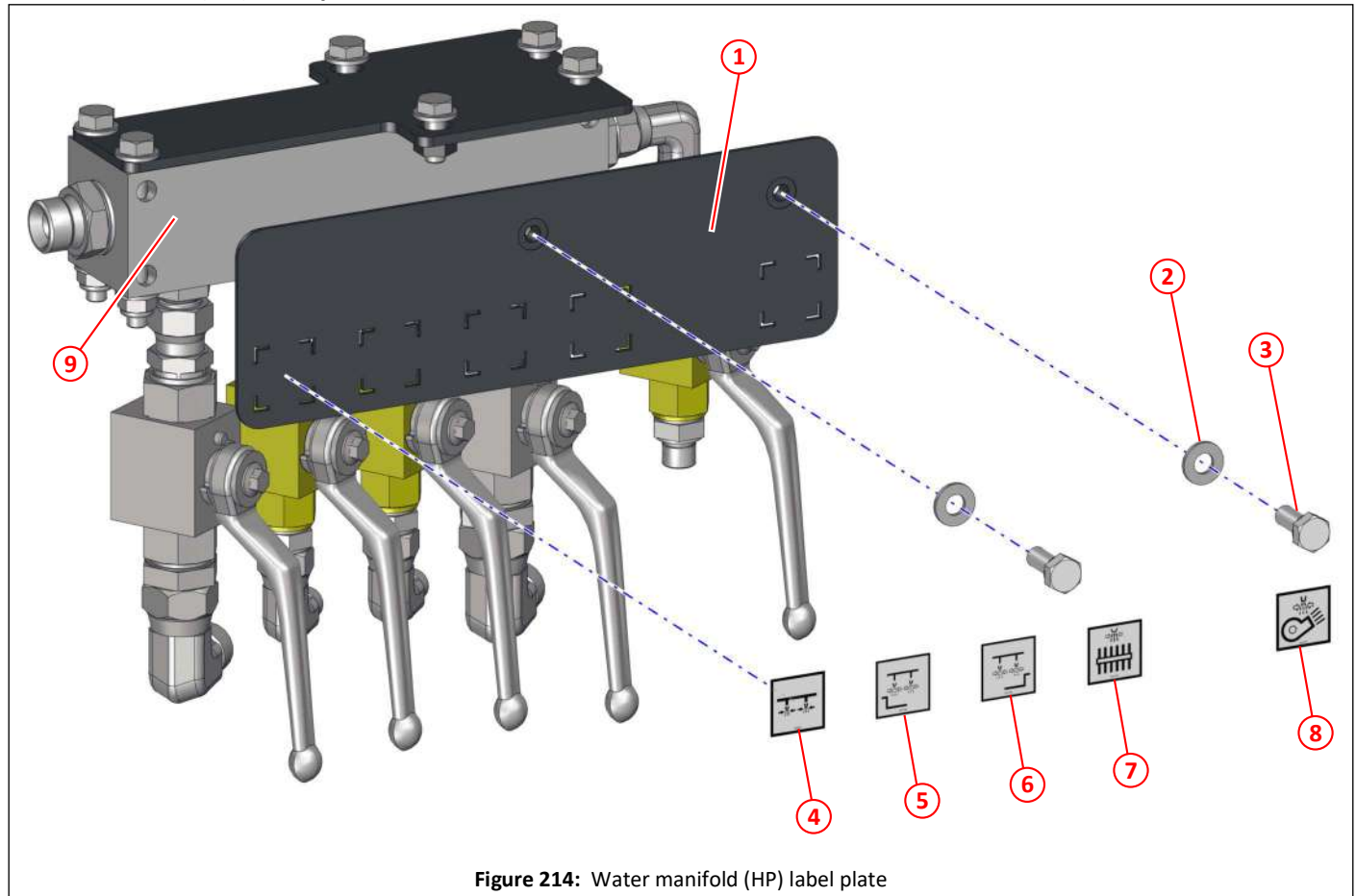

Figure 214: Water manifold (HP) label plate

Item	Part No	Qty	Description
①	047375	1	Label plate, water manifold
②	000419	2	Washer M8, OD ϕ 17
③	000256	2	Setscrew M8 x 20, stainless steel
④	039547	1	Label - High pressure front spray bar
⑤	047788	1	Label - Left hand suction nozzle box high pressure spray bar
⑥	047789	1	Label - Right hand suction nozzle box high pressure spray bar
⑦	047790	1	Label - Central brush (wide sweep) high pressure spray bar
⑧	047791	1	Label - Fan wash
⑨	047247	1	Manifold, 2 x $\frac{1}{2}$ " BSP ports and 4 x $\frac{3}{8}$ " BSP ports

Water manifold (HP) mounting bracket

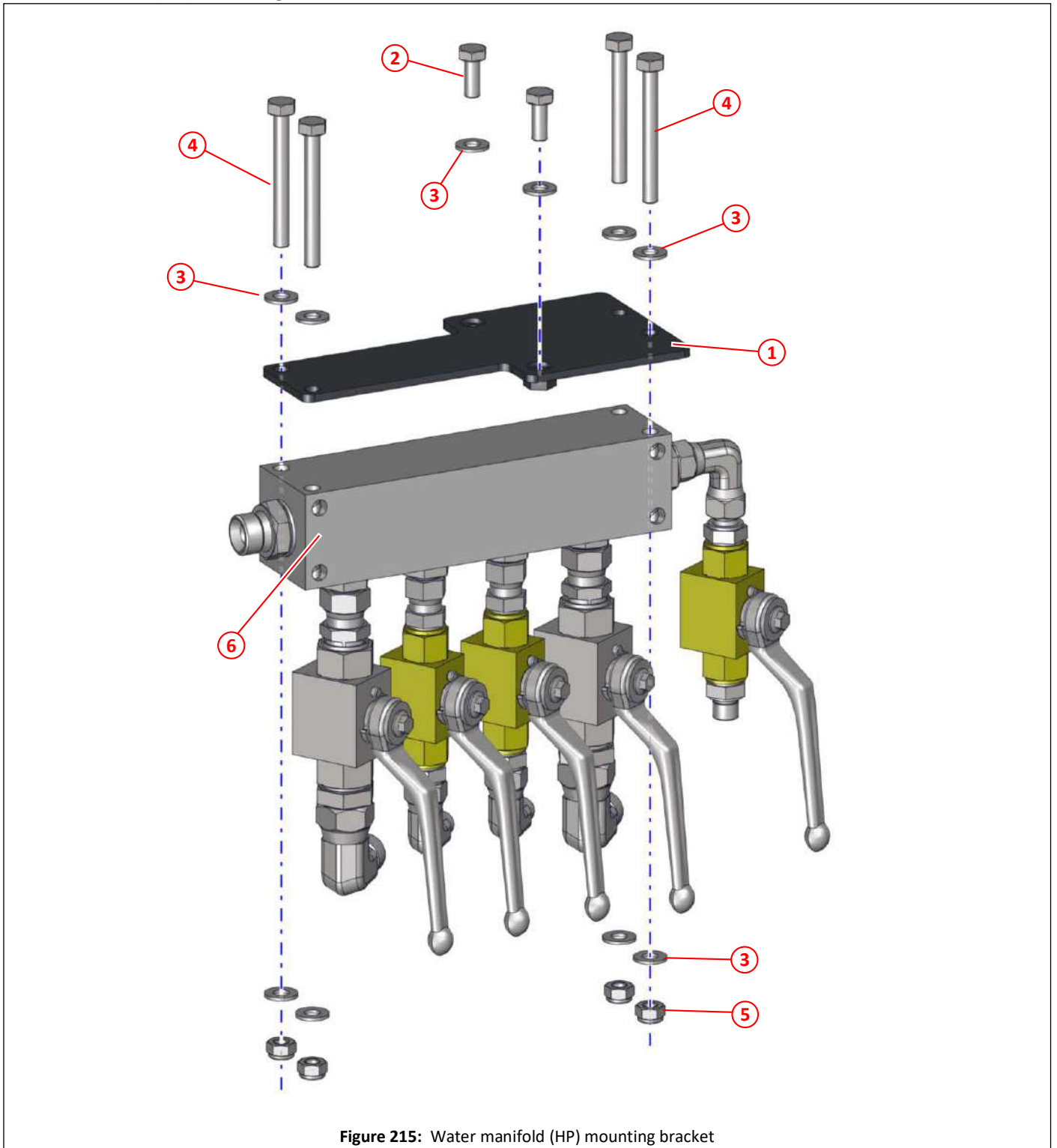

Figure 215: Water manifold (HP) mounting bracket

Item	Part No	Qty	Description
①	047248	1	Mount, water manifold
②	011010	2	Setscrew M8 x 20
③	000419	10	Washer M8, OD ϕ 17
④	011018	4	Bolt M8 x 70
⑤	011073	4	Nyloc nut T M8
⑥	047247	1	Manifold, 2 x $\frac{1}{2}$ " BSP ports and 4 x $\frac{3}{8}$ " BSP ports

Water manifold (HP) fittings, valves, and hoses

i This illustration shows a fully populated water manifold. The actual arrangement of valves and associated fittings could be different depending on the options fitted to the sweeper.

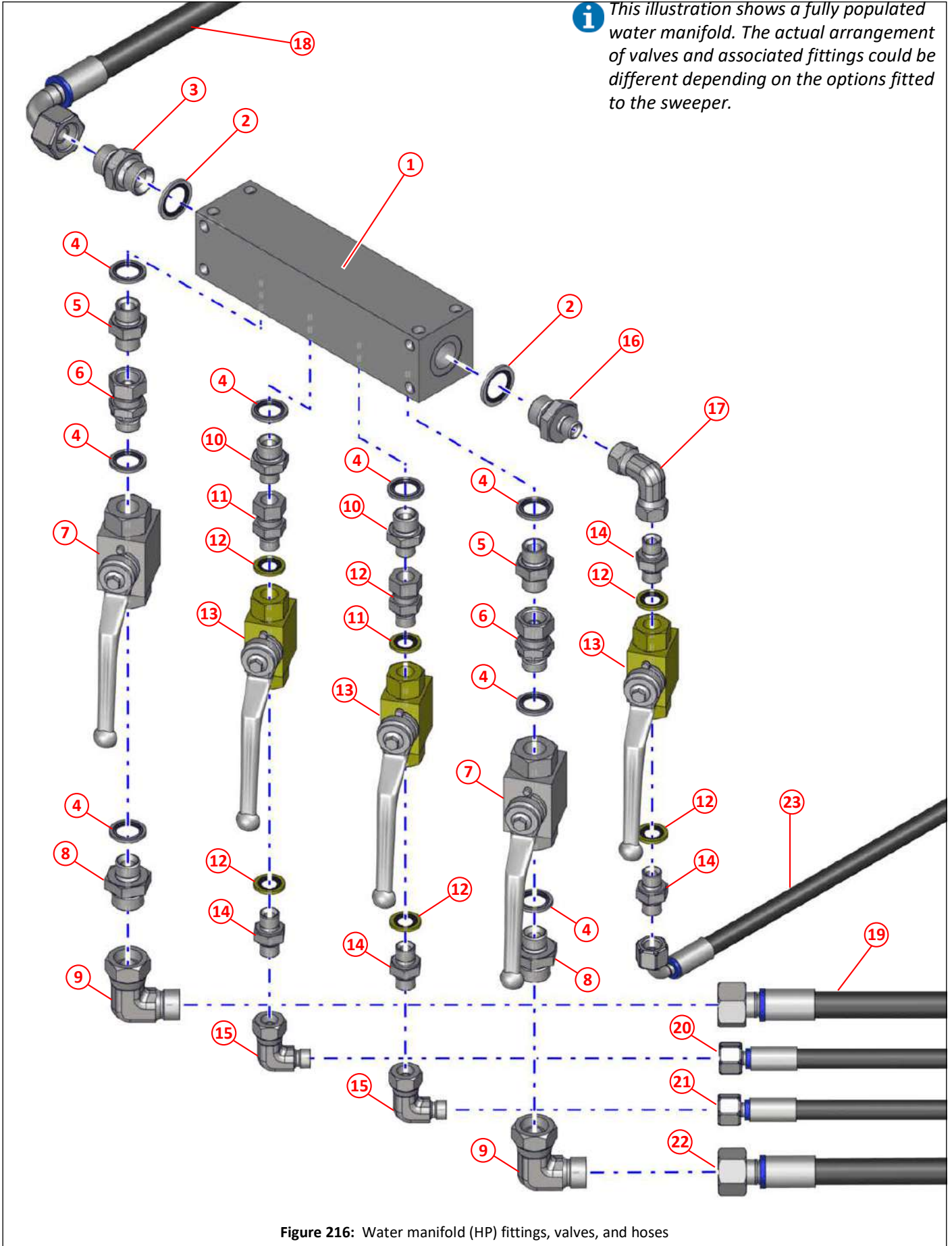
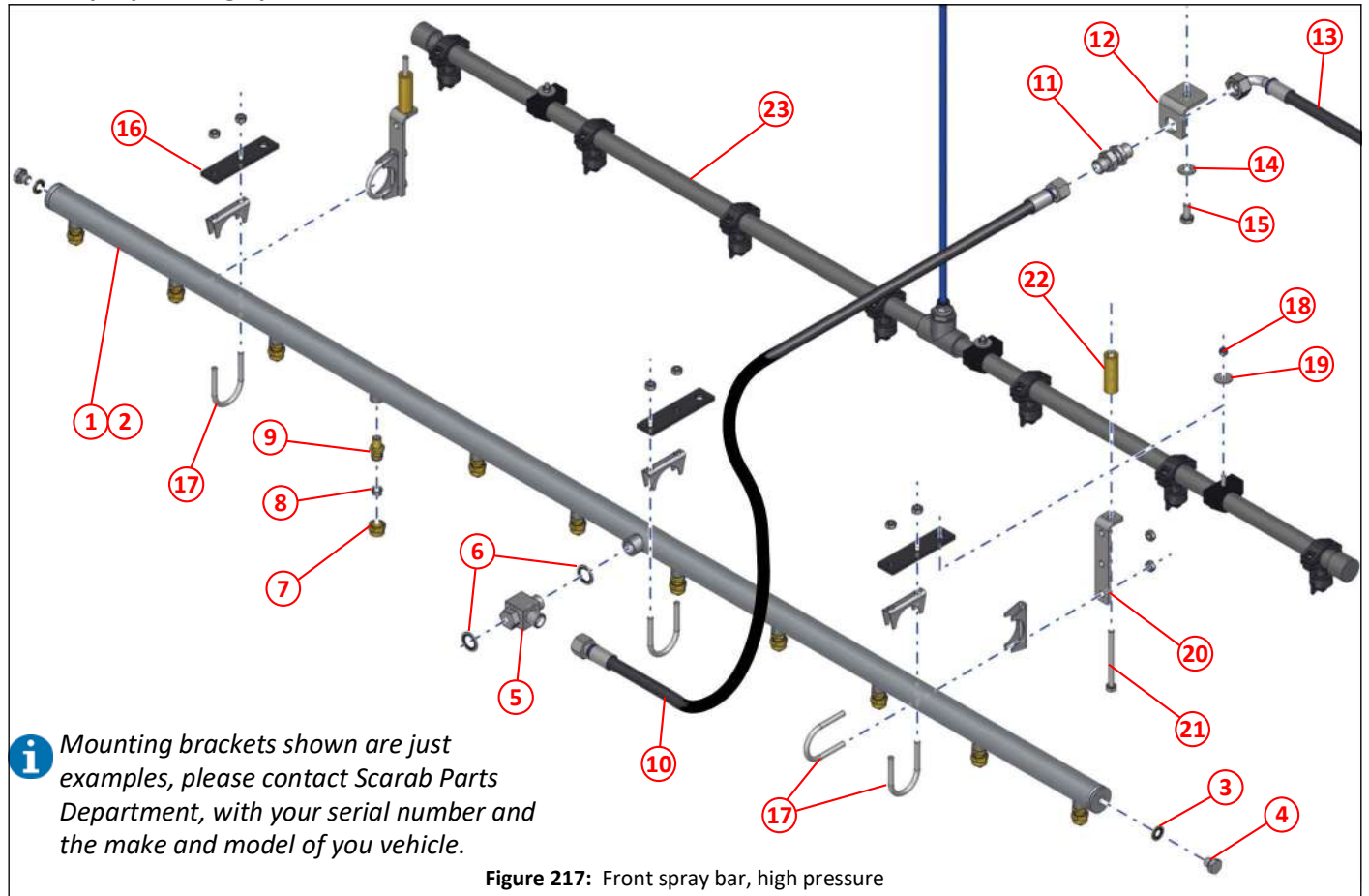

Figure 216: Water manifold (HP) fittings, valves, and hoses

Item	Part No	Qty	Description
①	047247	1	Manifold, 2 x $\frac{1}{2}$ " BSP ports and 4 x $\frac{3}{8}$ " BSP ports
②	011154	1	Dowty seal $\frac{1}{2}$ " BSP
③	011160	1	Adapter, $\frac{1}{2}$ " BSP
④	011153	8	Dowty seal $\frac{3}{8}$ " BSP
⑤	011159	2	Adapter, $\frac{3}{8}$ " BSP
⑥	002144	2	Adapter, swivel, $\frac{3}{8}$ " BSP, male/female
⑦	043201	2	Valve, ball, $\frac{3}{8}$ " BSP, high pressure
⑧	011167	2	Adapter, $\frac{1}{2}$ " BSP x $\frac{3}{8}$ " BSP
⑨	011173	2	Elbow, swivel, $\frac{1}{2}$ " BSP, male/female
⑩	011199	2	Adapter, $\frac{3}{8}$ " BSP x $\frac{1}{4}$ " BSP
⑪	002012	2	Adapter, swivel, $\frac{1}{4}$ " BSP, male/female
⑫	011152	6	Dowty seal $\frac{1}{4}$ " BSP
⑬	011257	3	Valve, ball, $\frac{1}{4}$ " BSP, high pressure
⑭	011158	4	Adapter, $\frac{1}{4}$ " BSP
⑮	011171	2	Elbow, swivel, $\frac{1}{4}$ " BSP, male/female
⑯	011165	1	Adapter, $\frac{1}{2}$ " BSP x $\frac{1}{4}$ " BSP
⑰	011169	1	Elbow, swivel, $\frac{1}{4}$ " BSP, female/female
⑱	001370	1	Hose $\frac{1}{2}$ " x 2430, straight/90° ends, from HP water pump
⑲	030992	1	Hose $\frac{1}{2}$ " x 1100, straight/90° ends, to front HP spray bar
⑳	001104	1	Hose $\frac{1}{4}$ " x 900, straight/90° ends, to left hand suction nozzle boost spray bar
㉑	001376	1	Hose $\frac{1}{4}$ " x 3400, straight/90° ends, to right hand suction nozzle boost spray bar
㉒	001242	1	Hose $\frac{1}{2}$ " x 1750, straight/straight ends, to central brush boost spray bar
㉓	001281	1	Hose $\frac{1}{4}$ " x 2800, straight/90° ends, to fan wash

Front spray bar, high pressure



i Mounting brackets shown are just examples, please contact Scarab Parts Department, with your serial number and the make and model of you vehicle.

Figure 217: Front spray bar, high pressure

Item	Part No	Qty	Description
①	031779	1	Front spray bar, high pressure, complete, includes ②, ③, ④, ⑤, ⑥, ⑦, ⑧, & ⑨
②	020405	1	Front spray bar, high pressure, no fittings
③	011152	2	Dowty seal 1/4" BSP
④	011241	2	Plug 1/4" BSP
⑤	011188	1	Banjo 1/2" BSP
⑥	011154	2	Dowty seal 1/2" BSP
⑦	030951	11	Nozzle cap
⑧	023377	11	Spray jet
⑨	010112	11	Nozzle body
⑩	001066	1	Hose 1/2" x 3000, straight ends
⑪	011268	1	Adapter, bulkhead, 1/2" BSP
⑫	025007	1	Angle bracket
⑬	030992	1	Hose, 1/2" x 1100, straight/90° ends, from water manifold (HP)
⑭	011094	1	Washer M10
⑮	011030	1	Setscrew HT M10 x 20
⑯	030392	3	Bracket, spray bar
⑰	014983	5	'U' clamp 1 5/8"
⑱	011071	3	Nyloc nut T M6
⑲	011099	3	Repair washer, 1/4" x ø1"
⑳	031921	2	Bracket, HP and LP spray bar
㉑	011019	2	Bolt HT M8 x 90
㉒	012943	2	Spacer, ø10.5 x ø20 x 57
㉓	047716	1	Front spray bar, low pressure

Hose reel, high pressure

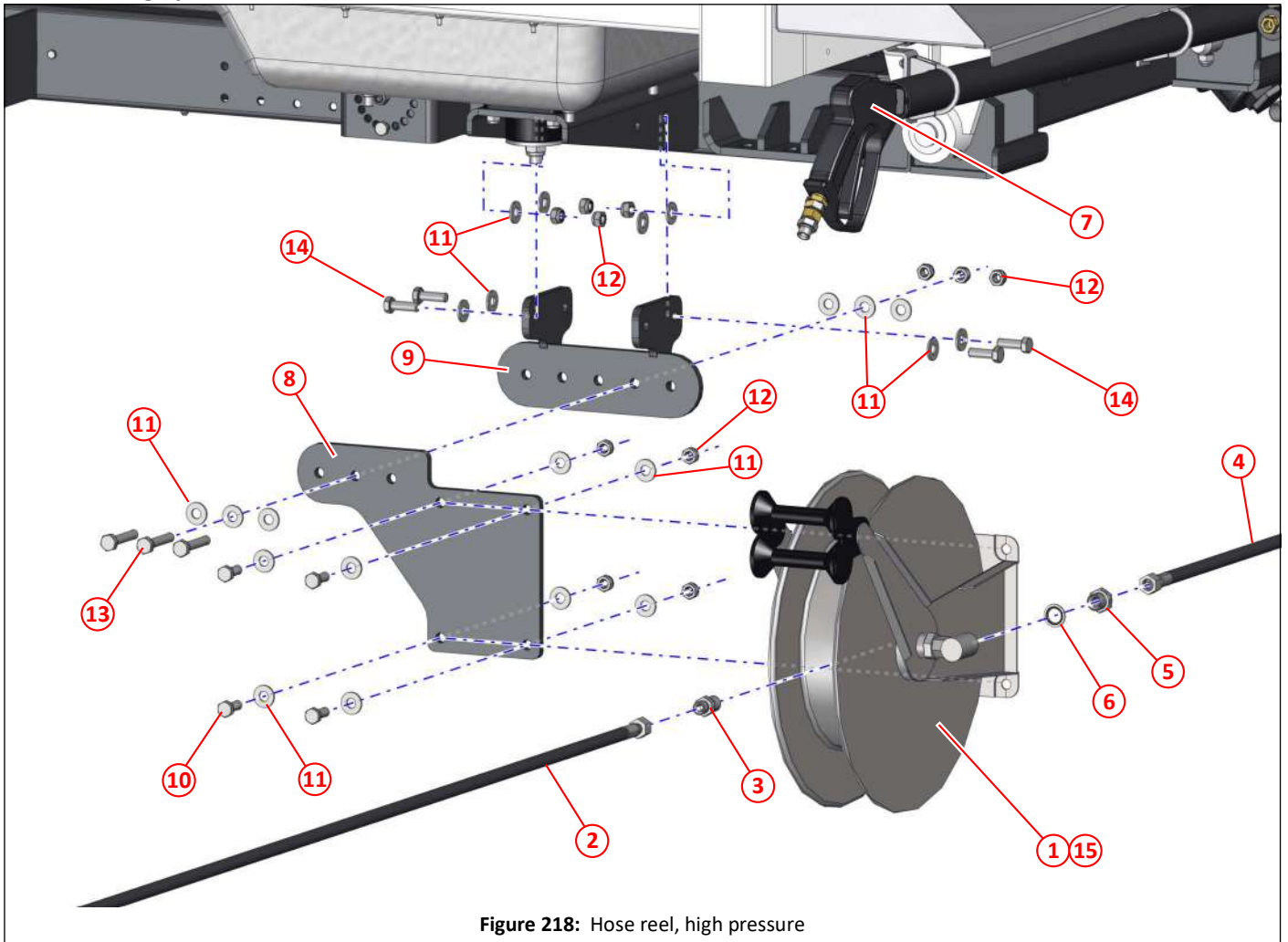

Figure 218: Hose reel, high pressure

Item	Part No	Qty	Description	
①	020451	1	Hose reel, retracting, no hose	
②	010601	1	Hose, $\frac{3}{8}$ " x 13 Meters	
③	002204	1	Adapter, $\frac{3}{8}$ " BSP x $\frac{1}{2}$ " NPT, straight	
④	001373	1	Hose, $\frac{3}{8}$ " x 900, straight/90° ends, from high pressure water pump	
⑤	011167	1	Adapter, $\frac{1}{2}$ " BSP x $\frac{3}{8}$ " BSP	
⑥	011154	1	Dowty seal $\frac{1}{2}$ " BSP	
⑦	010748	1	Hand lance, water gun	255
⑧	048206	1	Mounting plate, hose reel	
⑨	048205	1	Bracket, option interface	
⑩	011052	4	Setscrew HT M12 x 30	
⑪	011096	22	Washer M12	
⑫	011077	11	Nyloc nut T M12	
⑬	011055	3	Bolt HT M12 x 65	
⑭	011053	4	Setscrew HT M12 x 35	
⑮	026753	1	Re-coil spring, replacement	

Detergent kit

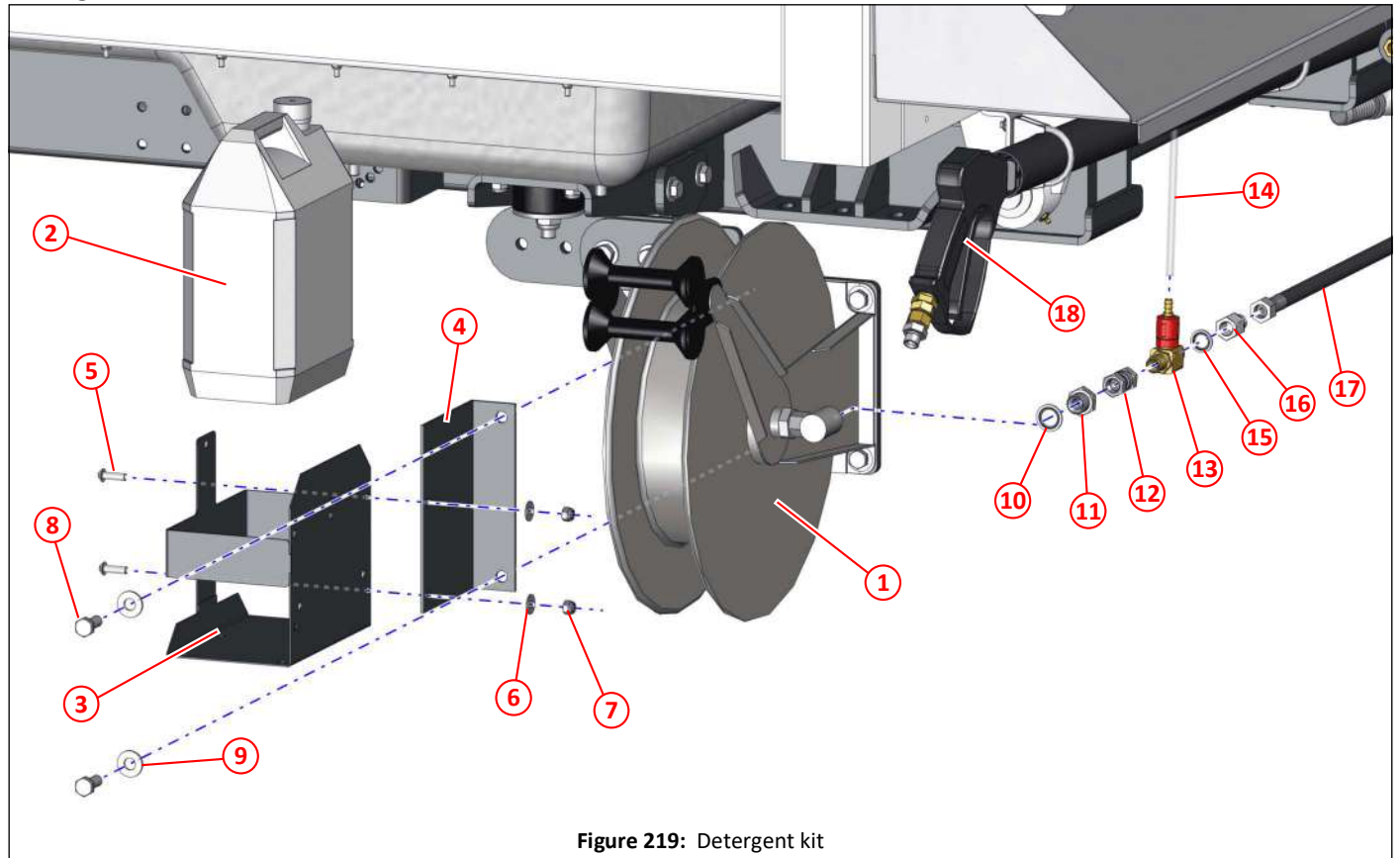

Figure 219: Detergent kit

Item	Part No	Qty	Description	
①	020451	1	Hose reel, retracting, no hose	253
②	013553	1	Detergent bottle, clear	
③	010393	1	Bracket, detergent bottle	
④	028250	1	Support bracket, detergent bottle bracket	
⑤	000281	2	Socket button head screw HD M8 x 25, stainless steel	
⑥	000264	2	Washer M8, stainless steel	
⑦	000263	2	Nyloc nut T M8, stainless steel	
⑧	011052	2	Setscrew HT M12 x 30	
⑨	011096	2	Washer M12	
⑩	011154	1	Dowty seal $\frac{1}{2}$ " BSP	
⑪	011167	1	Adapter, $\frac{1}{2}$ " BSP x $\frac{3}{8}$ " BSP	
⑫	011214	1	Adapter, $\frac{3}{8}$ " BSP, nut/nut	
⑬	013573	1	Detergent nozzle injector	
⑭	013575	1	Detergent silicone tube, cut to required length	
⑮	011153	1	Dowty seal $\frac{3}{8}$ " BSP	
⑯	002173	1	Adapter, fixed, $\frac{3}{8}$ " BSP, male/female	
⑰	001373	1	Hose, $\frac{3}{8}$ " x 900, straight/90° ends, from high pressure water pump	
⑱	010748	1	Hand lance, water gun	255

Hand lance, water gun

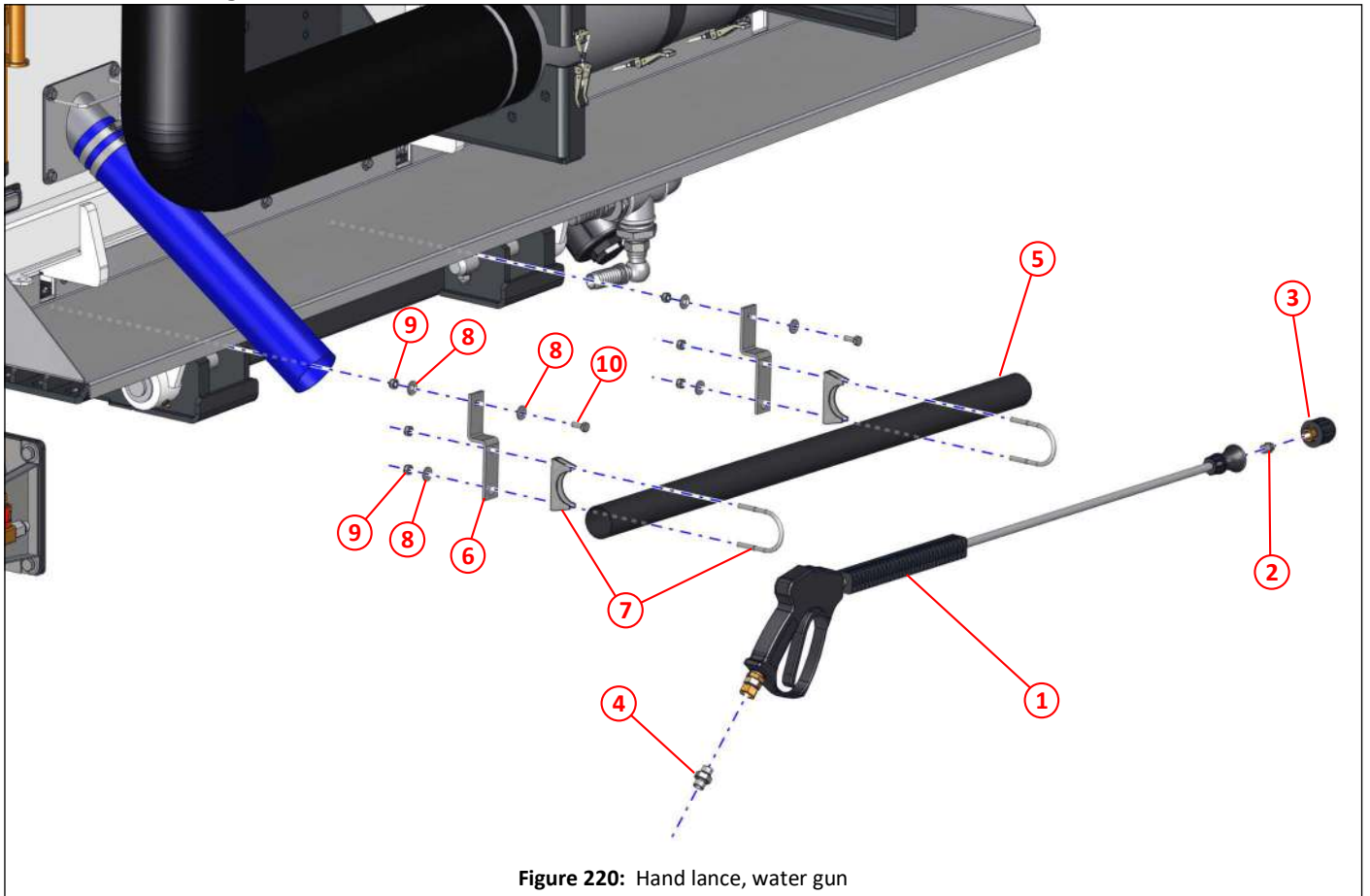

Figure 220: Hand lance, water gun

Item	Part No	Qty	Description	
①	010748	1	Hand lance, water gun	
②	020758	1	Nozzle 1520	
③	013574	1	Detergent nozzle	
④	011159	1	Adapter, $\frac{3}{8}$ " BSP, to hose from hose reel	
⑤	025473	1	Lance stowage	
⑥	032265	2	Lance holder mount, short	
⑦	012901	2	'U' clamp, 2", please note that the original nuts are replaced with item ⑧ and ⑨	
⑧	011092	6	Washer M8	
⑨	011073	6	Nyloc nut T M8	
⑩	011010	2	Setscrew HT M8 x 20	

Boost spray bar - Rear of LH suction nozzle

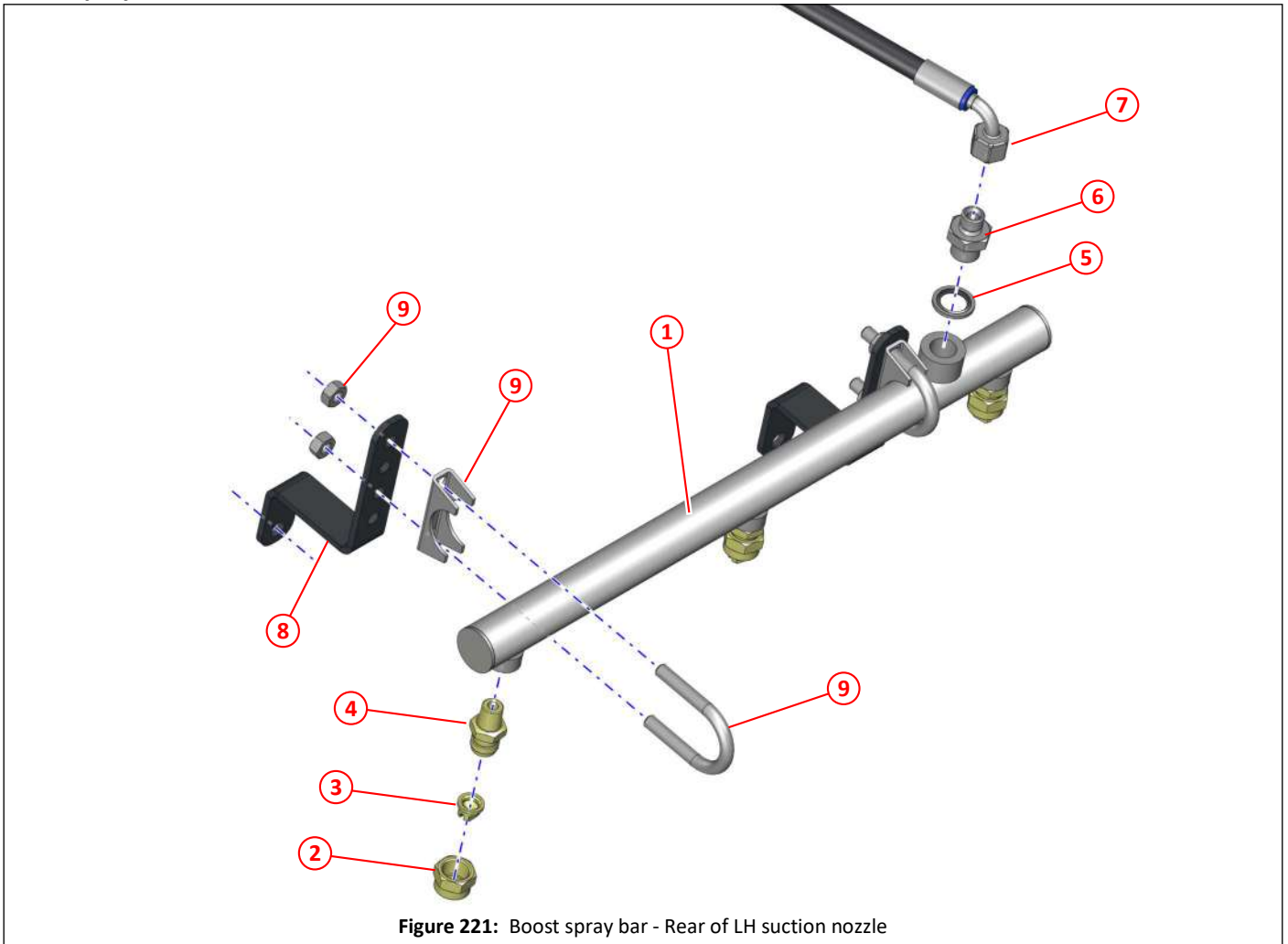

Figure 221: Boost spray bar - Rear of LH suction nozzle

Item	Part No	Qty	Description
①	047314	1	Boost spray bar, suction nozzle
②	030951 *	1	Nozzle cap
③	012316 *	1	Spray jet TPU-8004
④	010112 *	1	Nozzle body
⑤	011153	1	Dowty seal $\frac{3}{8}$ " BSP
⑥	011199	1	Adapter, $\frac{3}{8}$ " BSP x $\frac{1}{4}$ " BSP
⑦	001104	1	Hose $\frac{1}{4}$ " x 1020, straight/90° ends, MEGAFLEX, from water manifold (HP)
⑧	047358	2	Bracket, boost spray bar, suction nozzle, uses existing bolts in suction nozzle
⑨	020774	2	'U' clamp $\frac{1}{4}$ "

*. Quantity per nozzle

Boost spray bar - Rear of RH suction nozzle

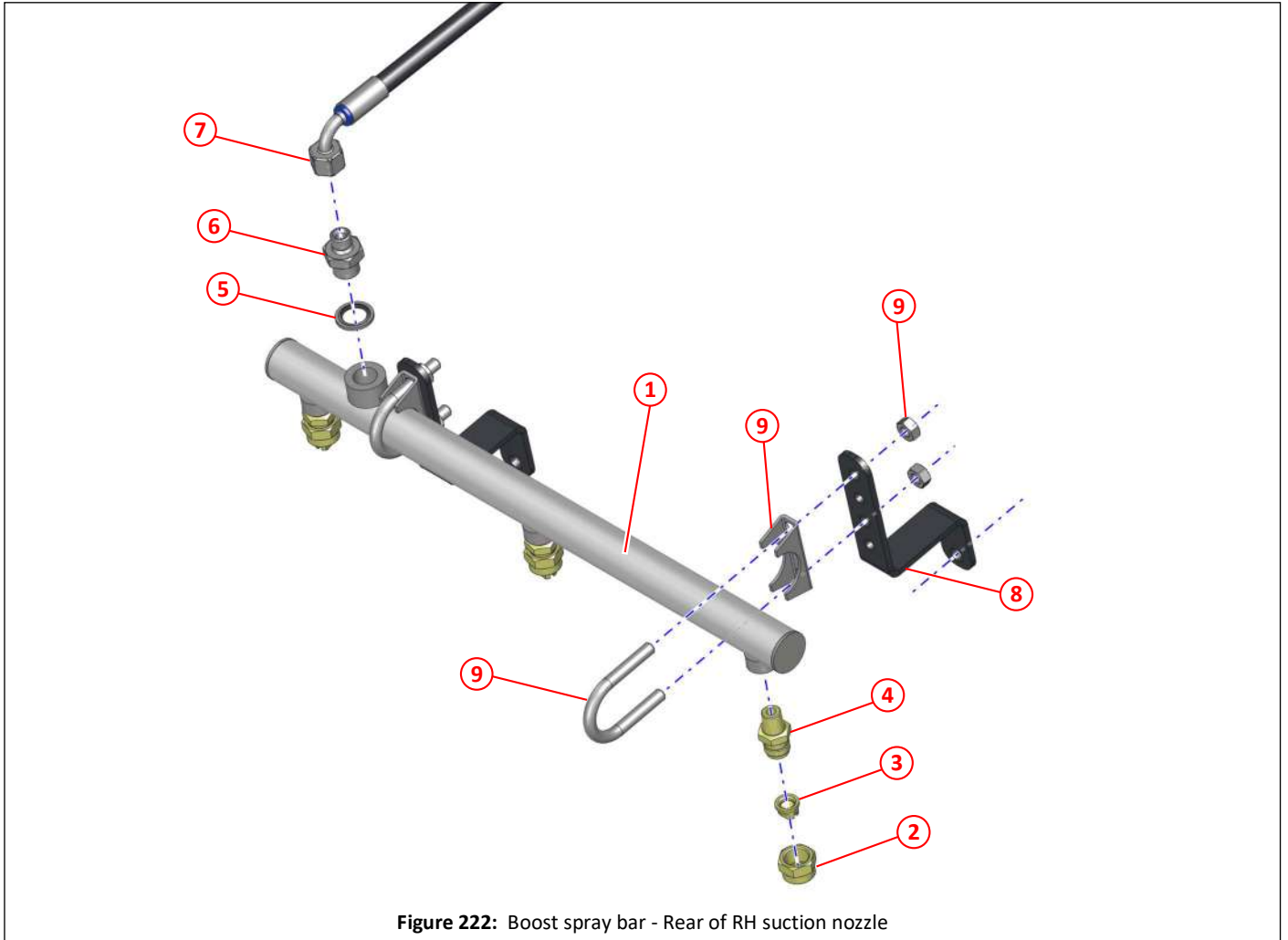

Figure 222: Boost spray bar - Rear of RH suction nozzle

Item	Part No	Qty	Description
①	047314	1	Boost spray bar, suction nozzle
②	030951 *	1	Nozzle cap
③	012316 *	1	Spray jet TPU-8004
④	010112 *	1	Nozzle body
⑤	011153	1	Dowty seal $\frac{3}{8}$ " BSP
⑥	011199	1	Adapter, $\frac{3}{8}$ " BSP x $\frac{1}{4}$ " BSP
⑦	001104	1	Hose $\frac{1}{4}$ " x 1020, straight/90° ends, MEGAFLEX, from water manifold (HP)
⑧	047358	2	Bracket, boost spray bar, suction nozzle, uses existing bolts in suction nozzle
⑨	020774	2	'U' clamp $1\frac{1}{4}$ "

*. Quantity per nozzle

Boost spray bar - Rear of central brush (wide sweep)

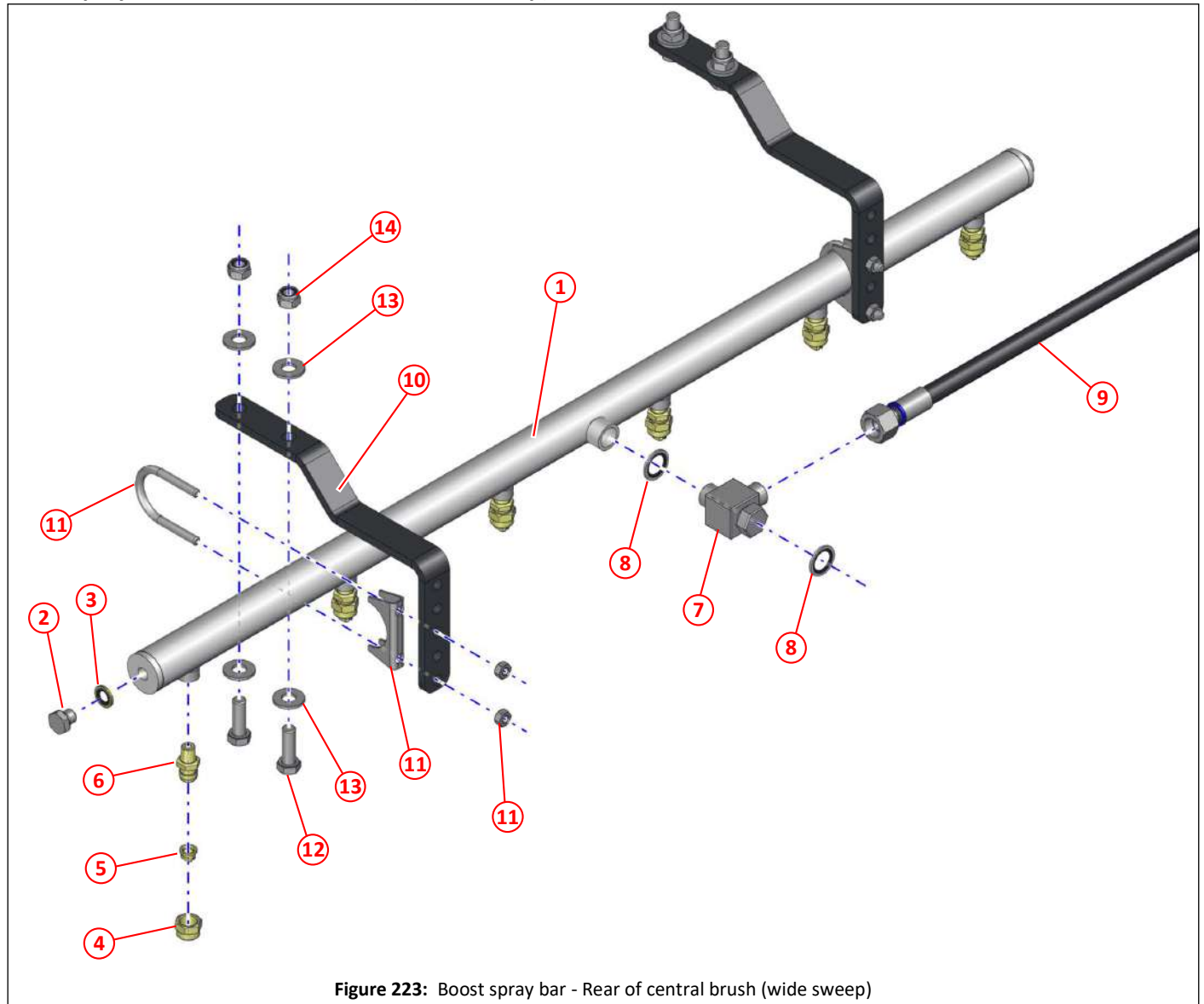

Figure 223: Boost spray bar - Rear of central brush (wide sweep)

Item	Part No	Qty	Description
①	041451	1	Boost spray bar, rear of central brush (wide sweep)
②	011241	2	Plug $\frac{1}{4}$ " BSP
③	011152	2	Dowty seal $\frac{1}{4}$ " BSP
④	030951 *	1	Nozzle cap
⑤	012316 *	1	Spray jet TPU-8004
⑥	010112 *	1	Nozzle body
⑦	011188	1	Banjo, $\frac{1}{2}$ " BSP
⑧	011154	2	Dowty seal $\frac{1}{2}$ " BSP
⑨	001242	1	Hose $\frac{1}{2}$ " x 1750, straight ends
⑩	041452	2	Bracket, central brush (wide sweep) spray bar mounting
⑪	014983	2	'U' clamp $1\frac{5}{8}$ "
⑫	011053	4	Setscrew HT M12 x 35
⑬	011096	8	Washer M12
⑭	011077	4	Nyloc nut T M12

*. Quantity per nozzle

Suction fan wash assist

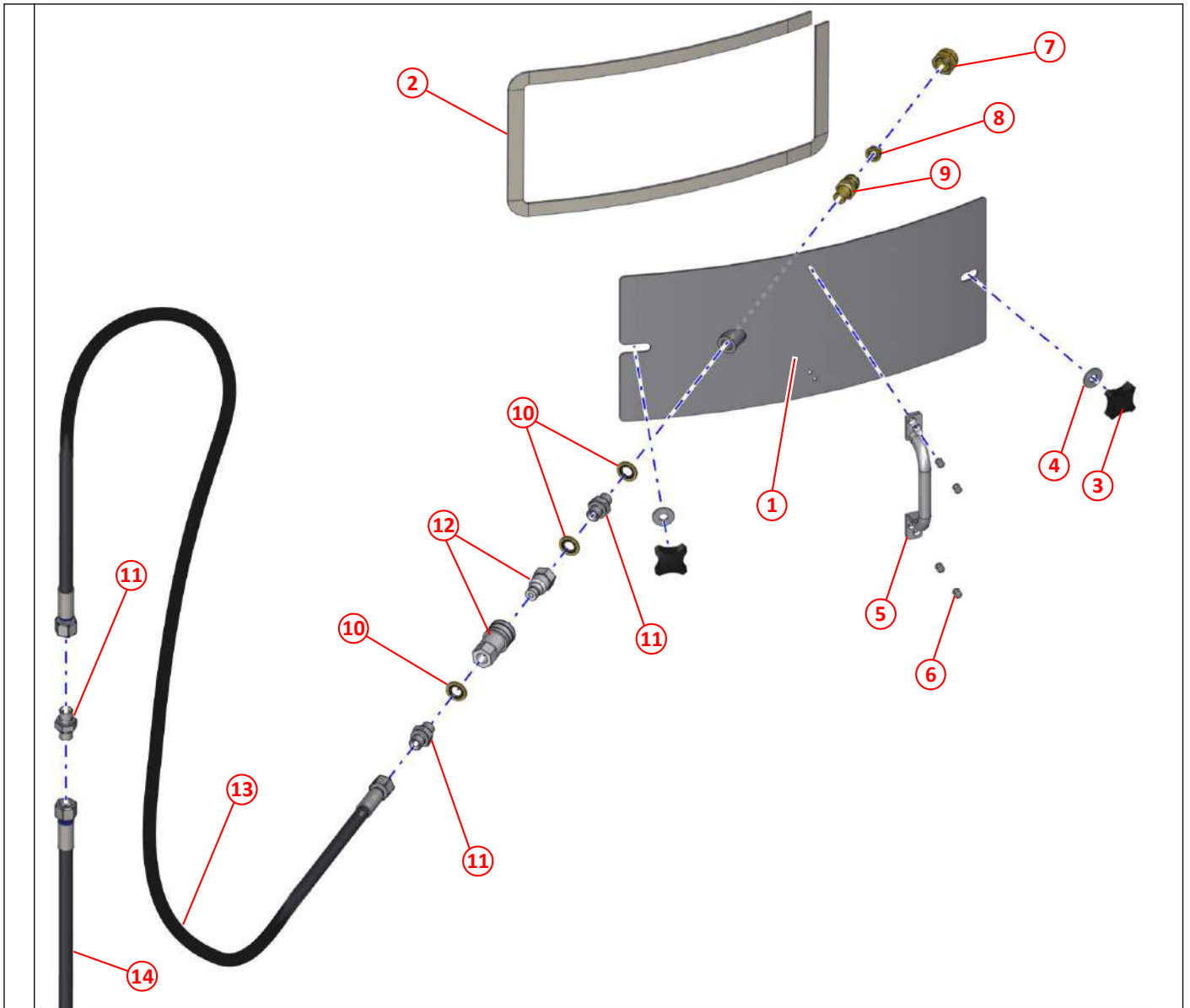

Figure 224: Suction fan wash assist

Item	Part No	Qty	Description
①	030731	1	Cover plate, quick release, fan wash assist
②	005020	1	Sealing strip, expanding, 25 x 15, cut to required length
③	000248	2	Grip nut, M8, with brass insert
④	000264	2	Washer M8, stainless steel
⑤	010502	1	Pull handle
⑥	011124	4	Blind rivet, $\phi 4.0 \times 10$
⑦	030951	1	Nozzle cap
⑧	012926	1	Spray jet TPU-8006
⑨	010112	1	Nozzle body
⑩	011152	3	Dowty seal $\frac{1}{4}$ " BSP
⑪	011158	3	Adapter $\frac{1}{4}$ " BSP
⑫	012985	1	Quick release coupling, $\frac{1}{4}$ " BSP
⑬	001002	1	Hose, $\frac{1}{4}$ " x 3700, straight ends
⑭	001281	1	Hose, $\frac{1}{4}$ " x 2800, straight/90° ends

Water tank filler arrangement

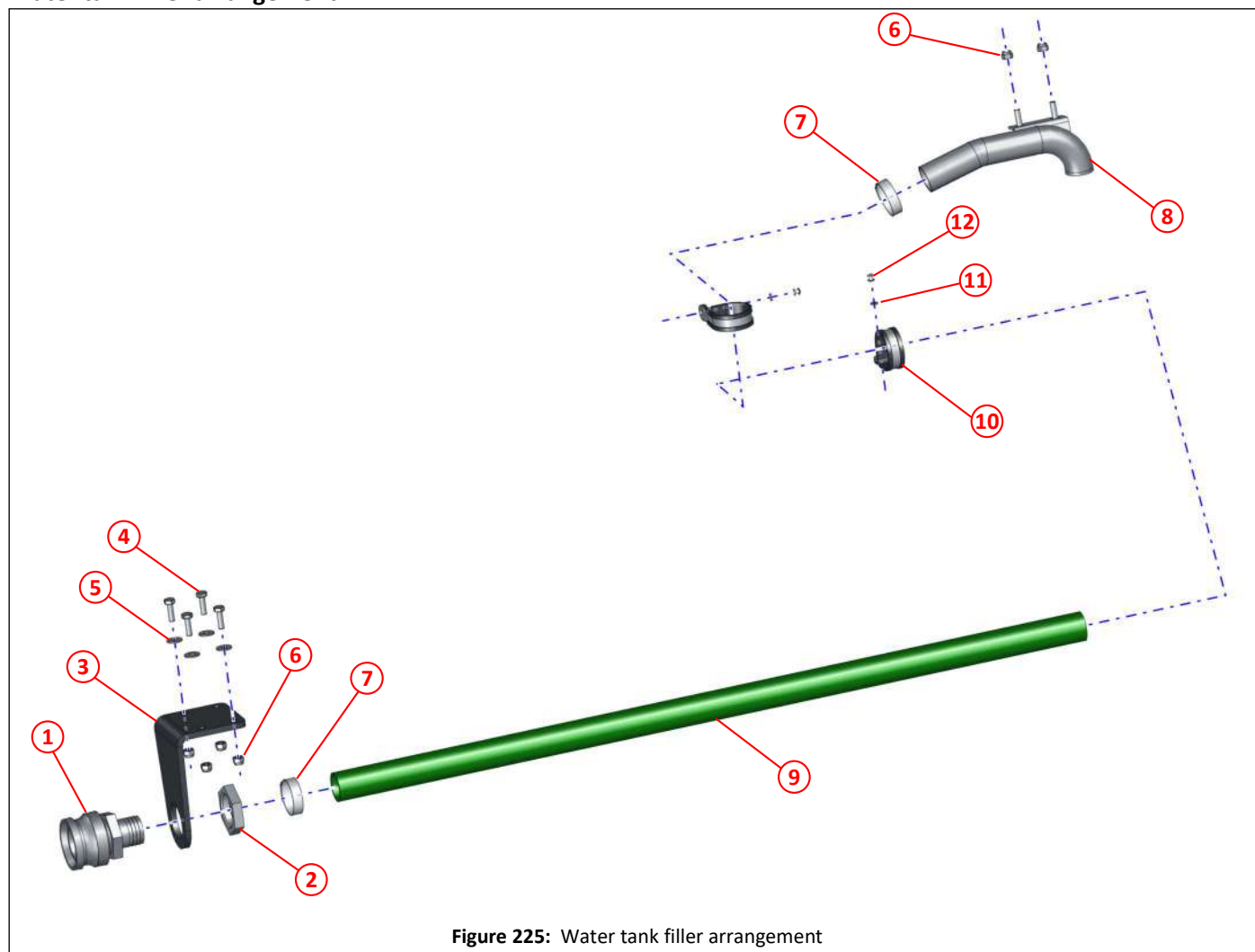

Figure 225: Water tank filler arrangement

Item	Part No	Qty	Description
①	025140	1	Hydrant adapter
②	003026	1	Back nut, 1½" BSP
③	044758	1	Bracket, hydrant adapter
④	000257	4	Setscrew M8 x 25, stainless steel
⑤	000264	4	Washer M8, stainless steel
⑥	000263	6	Nyloc nut T M8, stainless steel
⑦	003007	2	Jubilee clip No. 2A [ø35 - ø50]
⑧	034388	1	Filler pipe
⑨	001045	1	Hose, green medium duty, ø1½", cut to required length
⑩	005055	2	Clip ø50
⑪	000410	2	Washer M5
⑫	011131	2	Seal blind rivet ø4.8 x 18

Hydraulics

<i>Description</i>	<i>Page</i>
Engine frame hydraulics	262
Hydraulic tank arrangement	262
Hydraulic tank hoses	263
Hydraulic tank hose fittings	264
Hydraulic tank filters and fittings	265
Hydraulic fan pump and gear pumps	266
Hydraulic fan pump hoses	267
Hydraulic fan pump hose fittings	268
Hydraulic gear pump hoses	269
Hydraulic gear pump hose fittings	270
Hydraulic flow control valve hoses	271
Hydraulic flow control valve fittings	272
Hydraulic high pressure oil filters	273
Hydraulic fan and suction nozzle tilt control valve block, coils and solenoids	274
Hydraulic fan and suction nozzle tilt control valve block, hoses and fittings	275
Main and option valve blocks in hydraulic cabinet	276
Main valve block, coils, solenoids, check valves and plugs - 12 volt systems	277
Main valve block, coils, solenoids, check valves and plugs - 24 volt systems	278
Main valve block, fittings	279
Main valve block, pipes and hoses	280
Option valve block, coils, solenoids, check valves and plugs - 12 volt systems	281
Option valve block, coils, solenoids, check valves and plugs - 24 volt systems	282
Option valve block, fittings	283
Option valve block, pipes and hoses	284
Hopper and subframe hydraulics	285
Hopper and rear door control valve	285
Hopper and rear door control valve - hoses	286
Hydraulic hand pump	287
Hopper lift ram	288
Hopper door ram	289
Suction fan motor	290
Steel pipes for suction fan - hopper rear left mounted	292
Steel pipes for hopper rear door ram and suction fan drain - hopper rear right mounted	294
Hopper door locking arrangement	296
Sequence and pilot check valve block, hopper door locking	297
Hopper door locking assembly, middle and left side	298
Hopper door locking assembly, right side	299
Door locking manifolds and pressure relief valve	300
Steel pipes, fittings and hoses for dual sweep brushes	301
Clamps for steel pipes for dual sweep brushes	302
Steel pipes, fittings and hoses for right hand sweep brushes	303
Clamps for steel pipes for right hand sweep brushes	304
Steel pipes, fittings and hoses for left hand sweep brushes	305
Clamps for steel pipes left hand sweep brushes	306
Side brush motor	307
Central brush (wide sweep) motor	308
Low pressure water pump motor	309
High pressure water pump motor	310
Side brush lift ram	311
Suction nozzle tilt ram	312

Engine frame hydraulics

Hydraulic tank arrangement

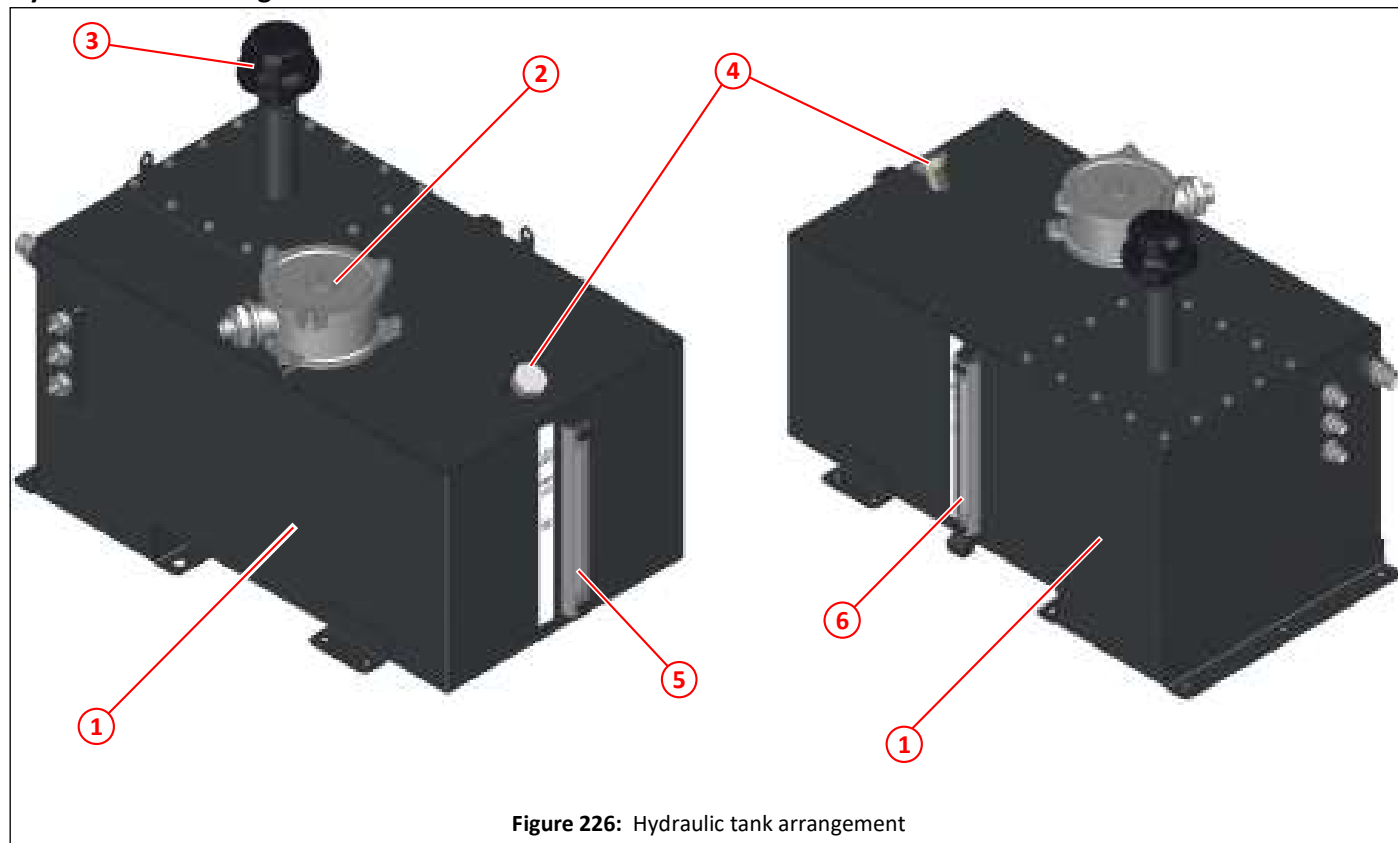

Figure 226: Hydraulic tank arrangement

Item	Part No	Qty	Description
①	046937	1	Hydraulic oil tank
②	013123	1	Filter, return
③	045445	1	Breather, filler
④	011136	1	Plug, filler 1" BSP
⑤	023155	1	Fluid level gauge
⑥	024039	1	Fluid level gauge, with switch

Hydraulic tank hoses

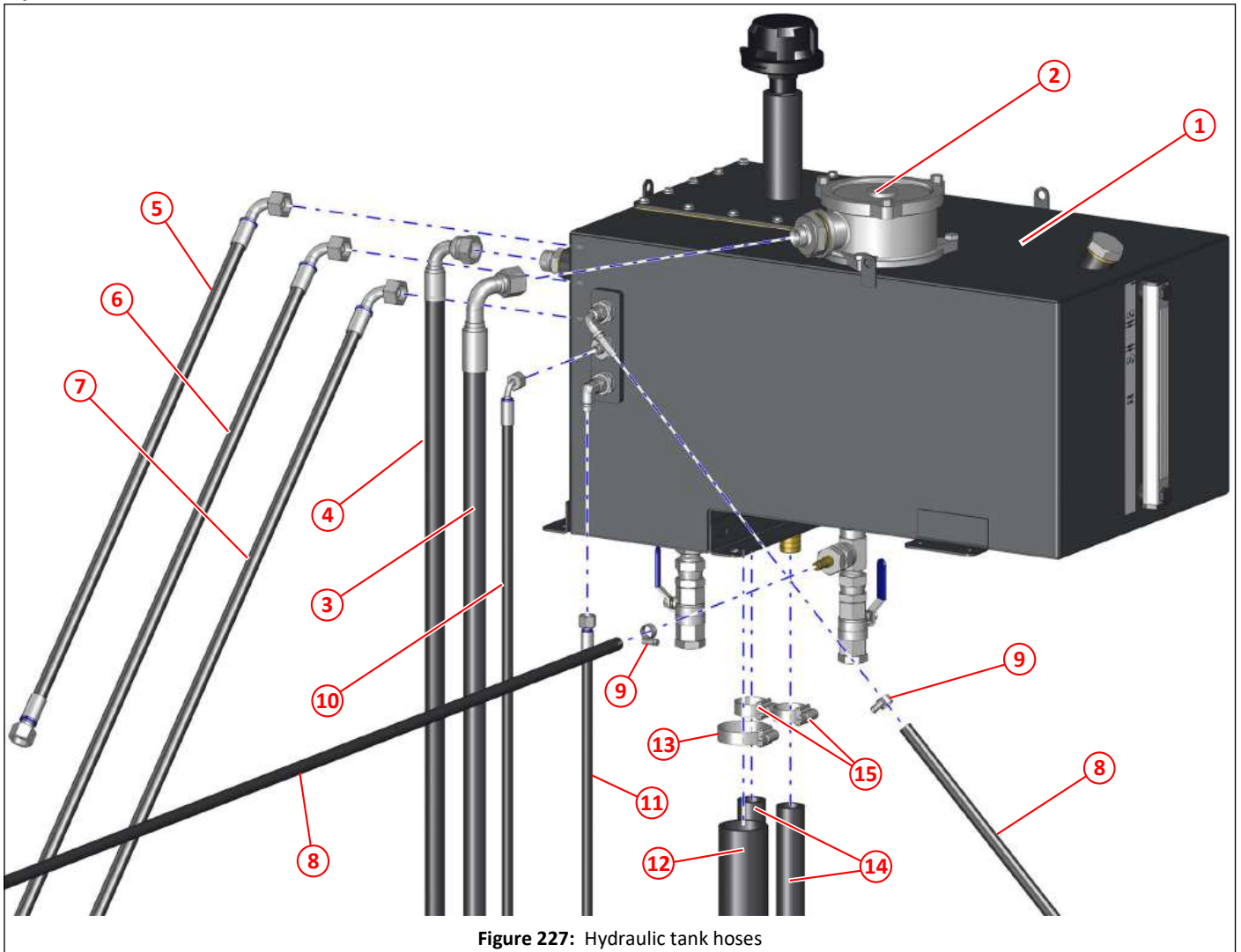

Figure 227: Hydraulic tank hoses

Item	Part No	Qty	Description
①	046937	1	Hydraulic oil tank
②	013123	1	Filter, return
③	001375	1	Hose $\frac{3}{4}$ " x 6225, straight and 90° ends, return from suction fan
④	001073	1	Hose $\frac{5}{8}$ " x 1600, with $\frac{3}{4}$ " BSP straight and 90° ends
⑤	001368	1	Hose $\frac{1}{2}$ " x 3370, straight and 90° ends
⑥	001345	1	Hose $\frac{1}{2}$ " x 2900, straight and 90° ends, from option valve block
⑦	001348	1	Hose $\frac{1}{2}$ " x 1400, straight and 90° ends
⑧	010958	2	Hose $\frac{3}{8}$ ", cut to required length(s)
⑨	010516	2	Jubilee clip No. MOO [ø11-ø16mm]
⑩	001104	1	Hose $\frac{1}{4}$ " x 1020, straight and 90° ends
⑪	001378	1	Hose $\frac{1}{4}$ " x 5425, straight and 90° ends
⑫	047366	1	Hose SD MEGAFLEX ø2" ø51mm, cut to required length
⑬	028778	1	Jubilee clip, high torque size 70 [ø55-ø70mm]
⑭	014827	2	Hose ø1", cut to required length(s)
⑮	014828	2	Jubilee clip, high torque, size 40 [ø30-ø40mm]

Hydraulic tank hose fittings

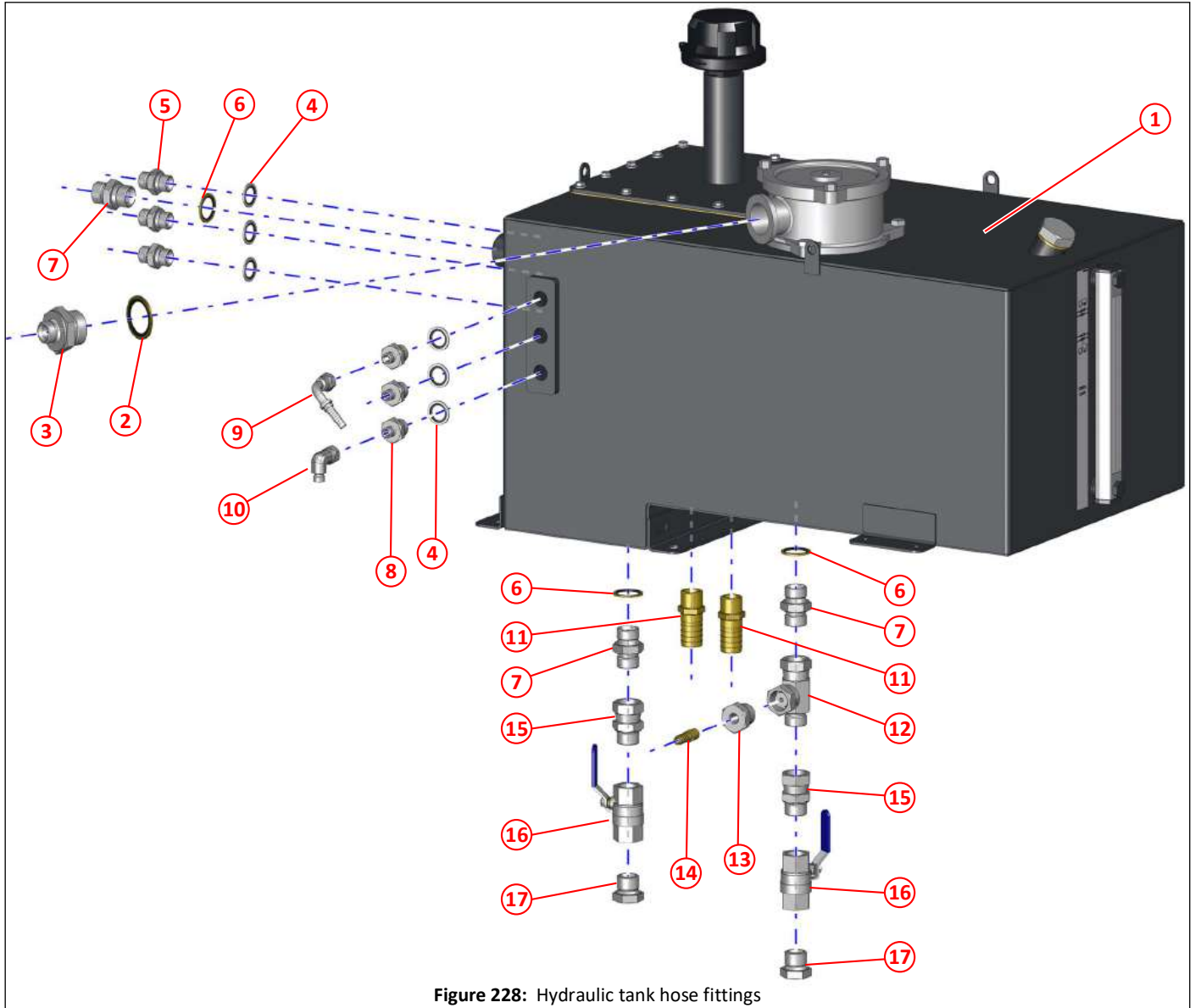

Figure 228: Hydraulic tank hose fittings

Item	Part No	Qty	Description
①	046937	1	Hydraulic oil tank
②	011150	1	Dowty seal 1 1/4" BSP
③	011184	1	Adapter 1 1/4" x 3/4" reducer
④	011154	6	Dowty seal 1/2" BSP
⑤	011160	3	Adapter 1/2" BSP, male/male
⑥	011155	3	Dowty seal 3/4" BSP
⑦	011161	3	Adapter 3/4" BSP
⑧	011165	1	Adapter 1/2" x 1/4" BSP
⑨	002237	1	Hosetail 1/4" BSPF x 3/8" hose, 90°
⑩	011171	1	Elbow, swivel, 1/4" BSP, male/female
⑪	010931	1	Hosetail 3/4" male x 1" hosetail
⑫	002233	1	Tee 3/4" BSP, male/female/female, nut on branch
⑬	021524	1	Filler plug 3/4" BSP X 1/4" BSPT, reducer
⑭	003010	1	Hosetail 1/4" BSPT x 3/8" hose
⑮	012228	2	Adapter 3/4" BSP x 3/4" BSP, male/female
⑯	013757	2	Valve, ball 3/4" BSP
⑰	011244	2	Plug 3/4" BSP

Hydraulic tank filters and fittings

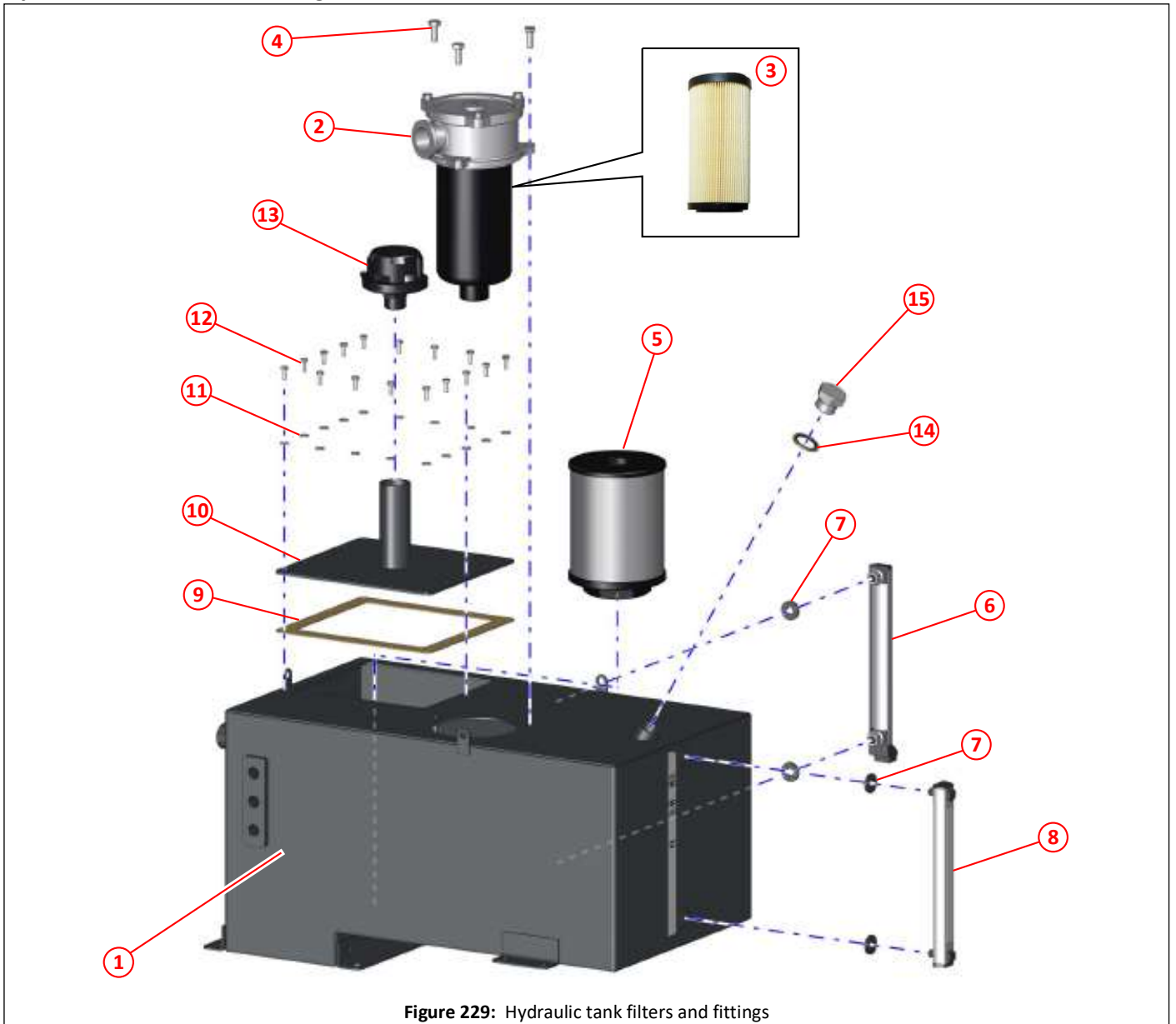

Figure 229: Hydraulic tank filters and fittings

Item	Part No	Qty	Description
①	046937	1	Hydraulic oil tank
②	013123	1	Filter, return, includes filter element
③	013125	1	Filter element, return filter
④	011031	3	Setscrew M10 x 25
⑤	048212	1	Strainer filter - 2.5" BSP ø150, 90 micron
⑥	024039	1	Fluid level gauge, with switch
⑦	036794	4	Rubber sealing washer ø30 x ø12 x 4
⑧	023155	1	Fluid level gauge
⑨	046938	1	Gasket, oil tank
⑩	046939	1	Oil tank lid
⑪	011090	16	Washer M6
⑫	011001	16	Setscrew M6 x 16
⑬	045445	1	Breather, filler
⑭	011156	1	Dowty seal 1" BSP
⑮	011136	1	Plug 1" BSP

Hydraulic fan pump and gear pumps

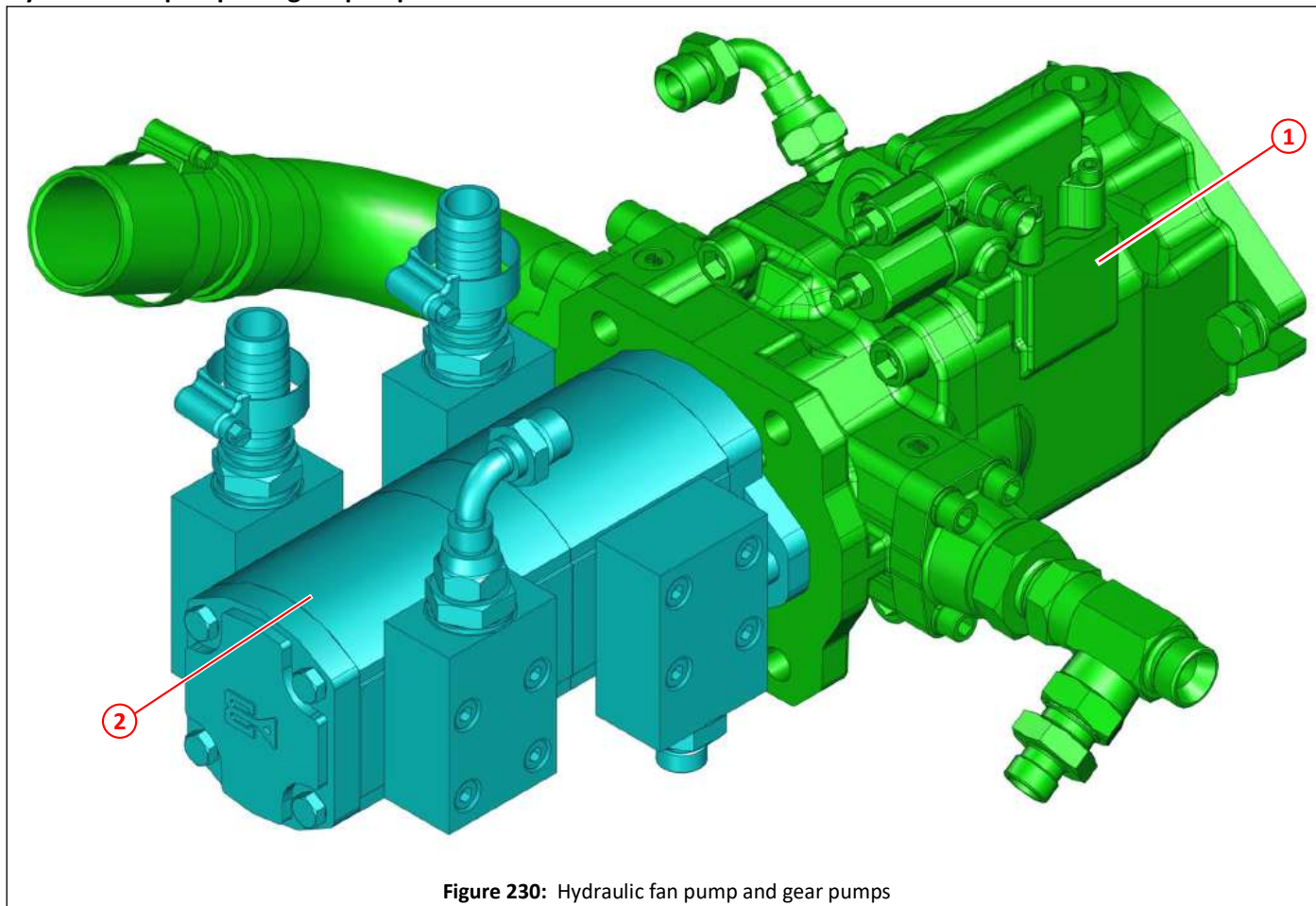

Figure 230: Hydraulic fan pump and gear pumps

Item	Part No	Qty	Description	
①	026235	1	Fan pump, A10VO60	
②	031970	1	Gear pump 23cc double	
NI	031971	1	Gear pump 23cc single	

Hydraulic fan pump hoses

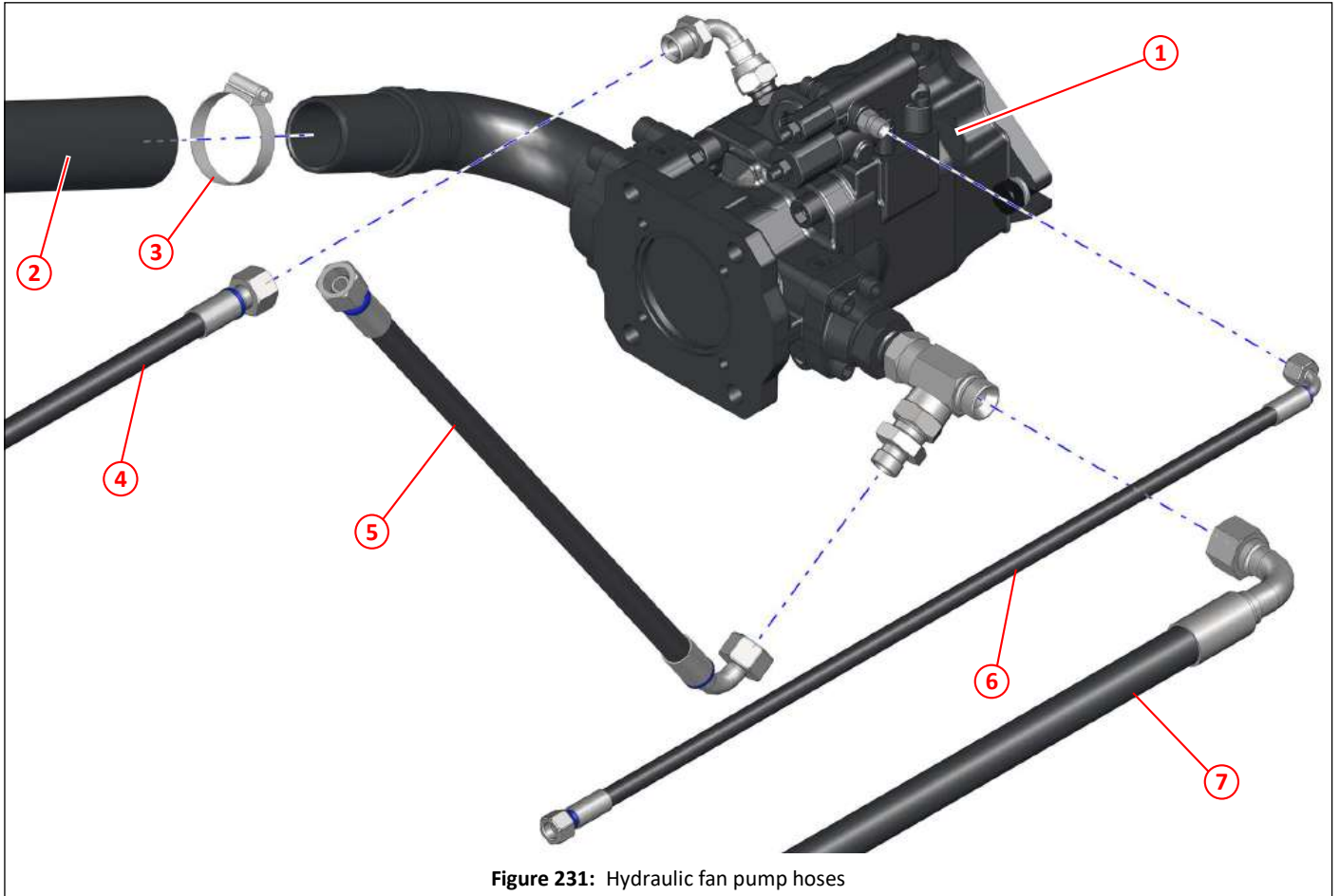

Figure 231: Hydraulic fan pump hoses

Item	Part No	Qty	Description	
①	026235	1	Fan pump, A10VO60	
②	047366	1	Hose SD MEGAFLEX $\phi 2''$ $\phi 51\text{mm}$, cut to required length	
③	012928	1	Jubilee clip No. 2X [$\phi 45 - \phi 60$]	
④	001348	1	Hose $\frac{1}{2}''$ x 1400, straight and 90° ends	
⑤	001076	1	Hose $\frac{1}{2}''$ x 600, straight and 90° ends	
⑥	001287	1	Hose $\frac{1}{4}''$ x 715, straight and 90° ends	
⑦	001374	1	Hose $\frac{3}{4}''$ x 5900, straight and 90° ends	

Hydraulic fan pump hose fittings

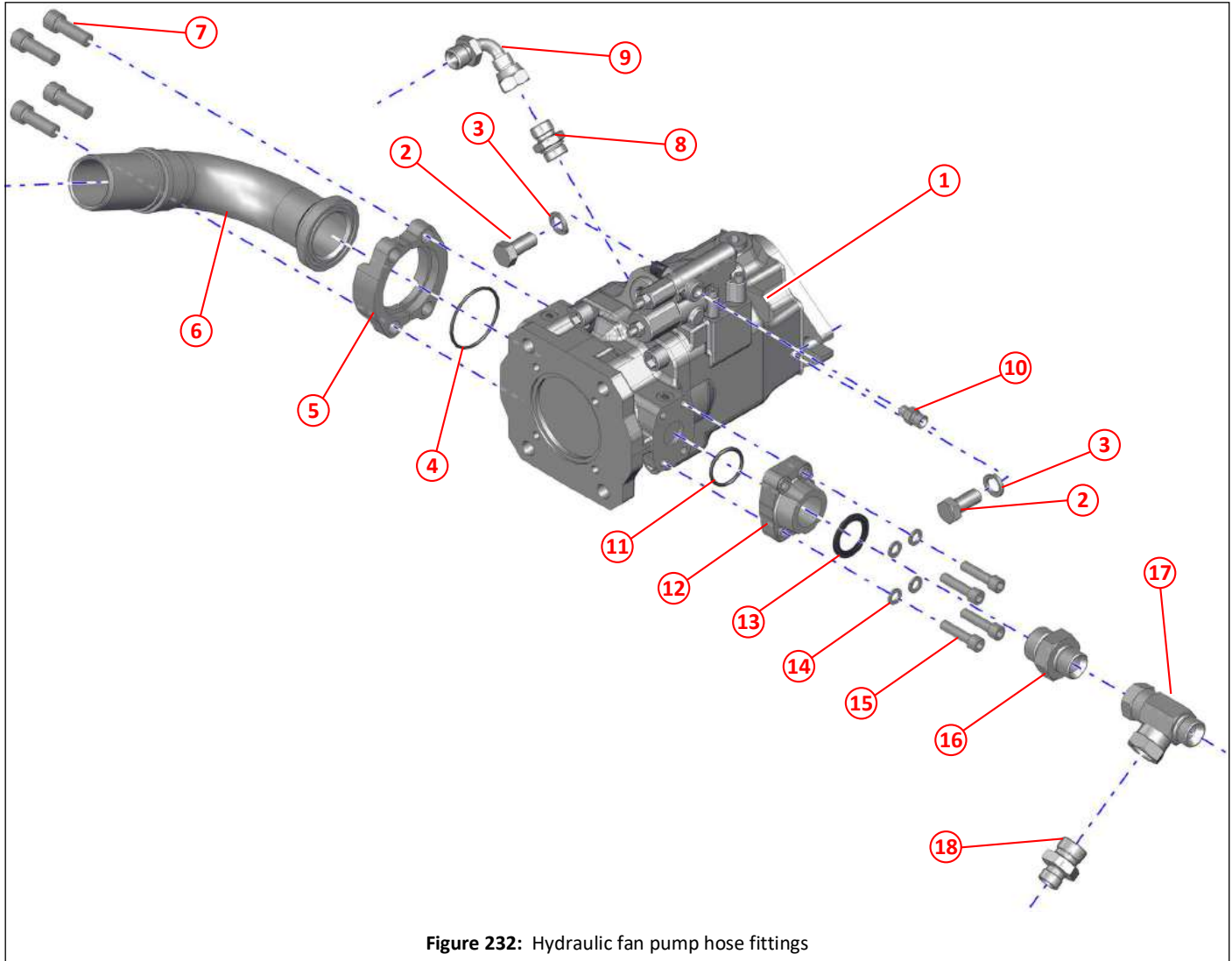

Figure 232: Hydraulic fan pump hose fittings

Item	Part No	Qty	Description
①	026235	1	Fan pump, A10VO60
②	000477	2	Setscrew HT M14 x 2 x 30 10.9, black
③	011106	2	Spring washer M14
④	002264	1	2" SAE O ring
⑤	002263	1	Flange 2" SAE split kit 3000 PSI
⑥	002298	1	Elbow, swept, 2" SAE TO 2" hose
⑦	011108	4	Socket cap head screw, 1/2" UNC x 1 1/2"
⑧	011226	1	Adapter 7/8" SAE x 1/2" BSP, complete with O ring
⑨	011176	1	Sweep elbow 1/2" BSP
⑩	011227	1	Adapter 7/16" SAE x 1/4" BSP, complete with O ring
⑪	013517	1	O ring, 1" SAE, BS 219 NITRILE 90 SHORE
⑫	014105	1	Flange 1" SAE 1" BSP
⑬	011156	1	Dowty seal 1" BSP
⑭	011406	4	Spring washer 3/8"
⑮	000045	4	Socket cap head screw 3/8" UNC x 1 1/2"
⑯	011193	1	Adapter 1" x 3/4" BSP
⑰	002233	1	Tee 3/4" BSP, male/female/female, nut on branch
⑱	011166	1	Adapter 3/4" x 1/2" BSP

Hydraulic gear pump hoses

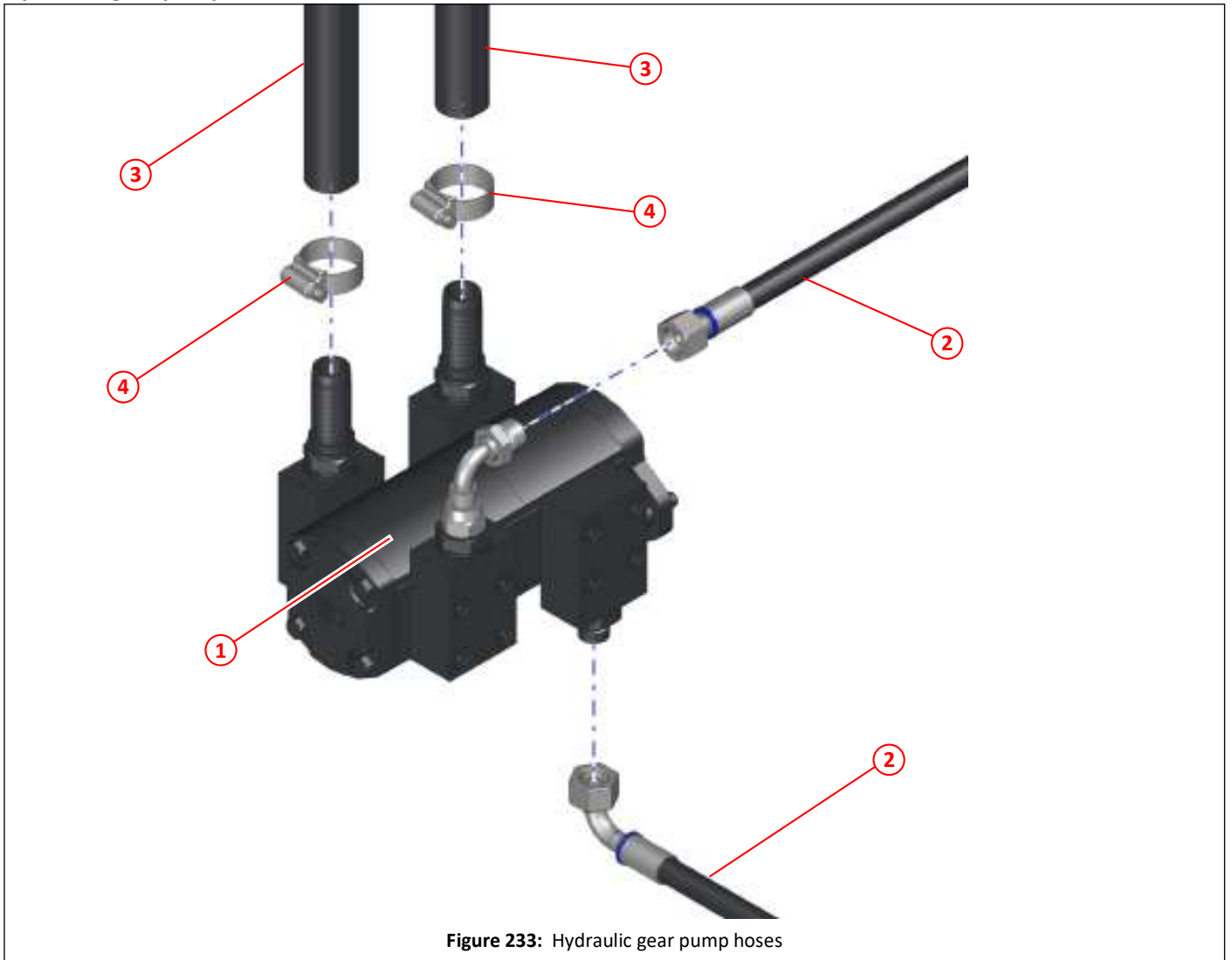
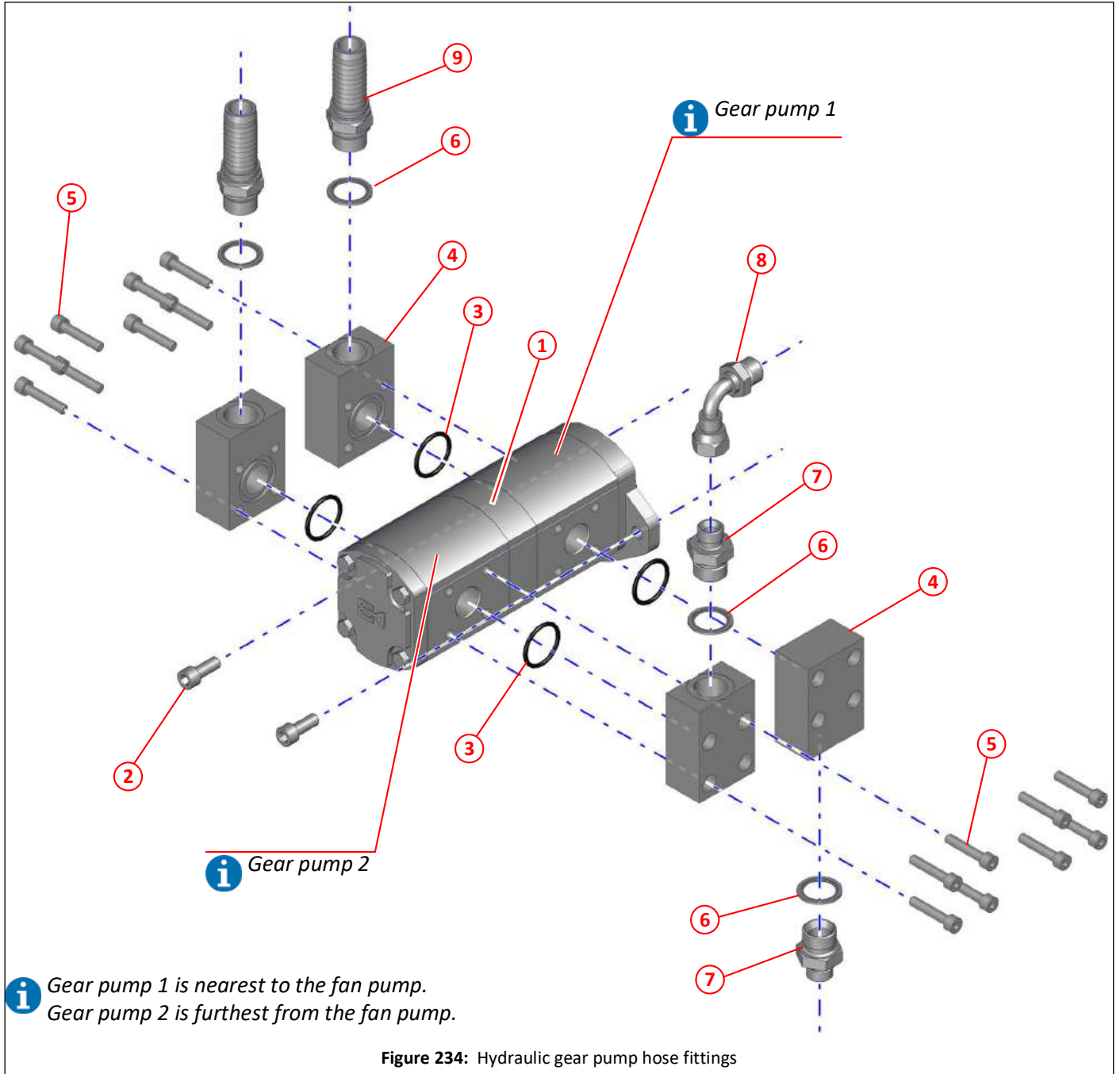

Figure 233: Hydraulic gear pump hoses

Item	Part No	Qty	Description	
①	031970	1	Gear pump 23cc double	
②	001165	2	Hose ½" x 670, straight and 90° ends	
③	014827	2	Hose ø1", cut to required length(s)	
④	014828	2	Jubilee clip, high torque, size 40 [ø30-ø40mm]	

Hydraulic gear pump hose fittings



Item	Part No	Qty	Description
①	031970 *	1	Gear pump 23cc double
②	011028	2	Socket cap head screw M10 x 25
③	013517	4	O ring, 1" SAE, BS 219 NITRILE 90 SHORE
④	026335	4	Adapter block, gear pump
⑤	000096	16	Socket cap head screw M8 x 40
⑥	011155	4	Dowty seal $\frac{3}{4}$ " BSP
⑦	011166	2	Adapter $\frac{3}{4}$ " x $\frac{1}{2}$ " BSP
⑧	011176	1	Elbow, sweep, $\frac{1}{2}$ " BSP
⑨	002252	2	Hosetail $\frac{3}{4}$ " BSP male x 1" hose

NI *	030629	1	Seal kit, gear pump 23cc double
*	031971	1	Gear pump 23cc single
NI *	030628	1	Seal kit, gear pump 23cc single

Hydraulic flow control valve hoses

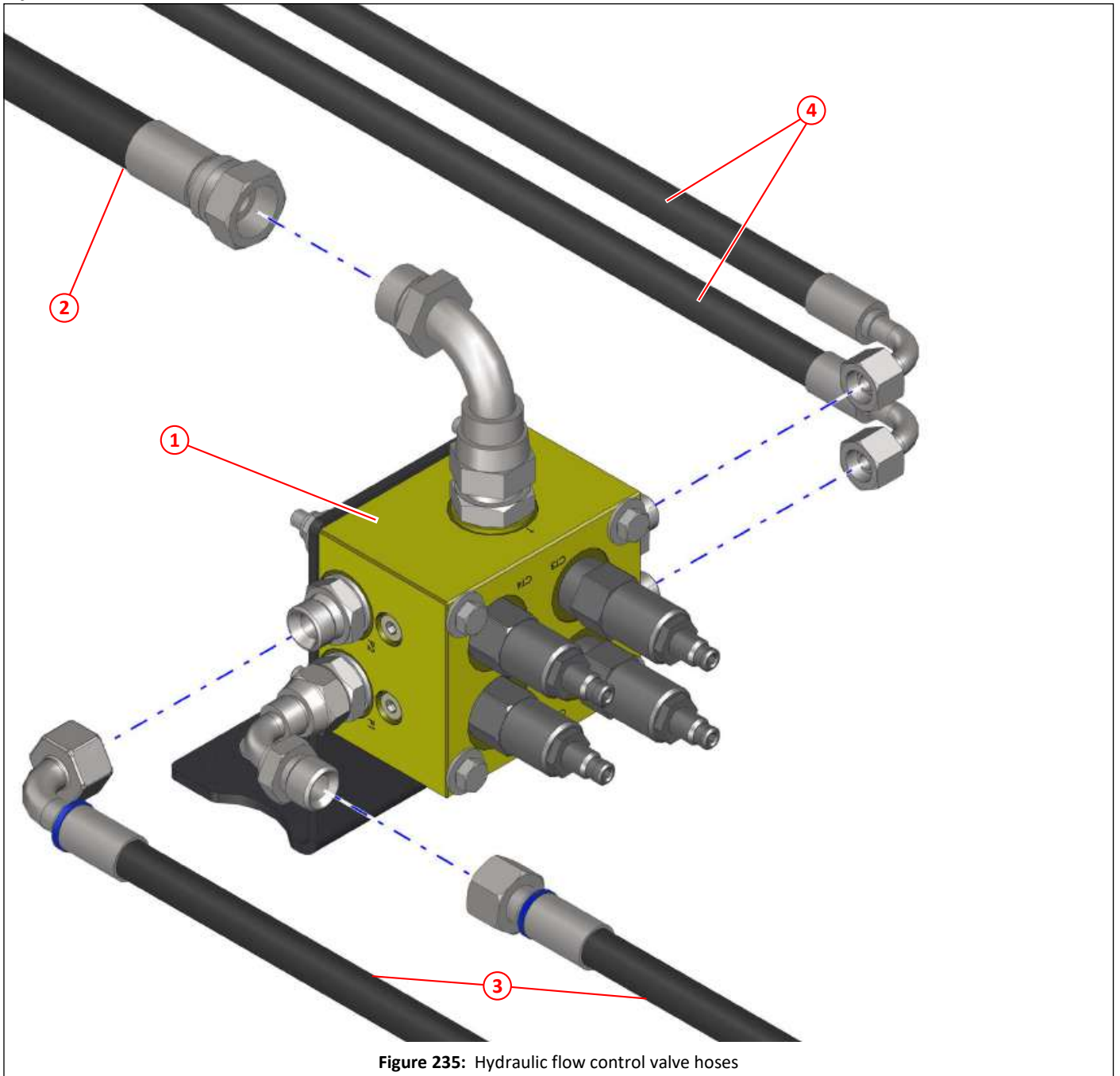

Figure 235: Hydraulic flow control valve hoses

Item	Part No	Qty	Description	
①	038513	1	Flow control, remote mounted, assembly	272,375
②	001073	1	Hose $\frac{5}{8}$ " x 1600, with $\frac{3}{4}$ " BSP straight and 90° ends	
③	001165	2	Hose $\frac{1}{2}$ " x 670, straight and 90° ends	
④	001360	2	Hose $\frac{3}{8}$ " x 940, straight and 90° ends	

Hydraulic flow control valve fittings

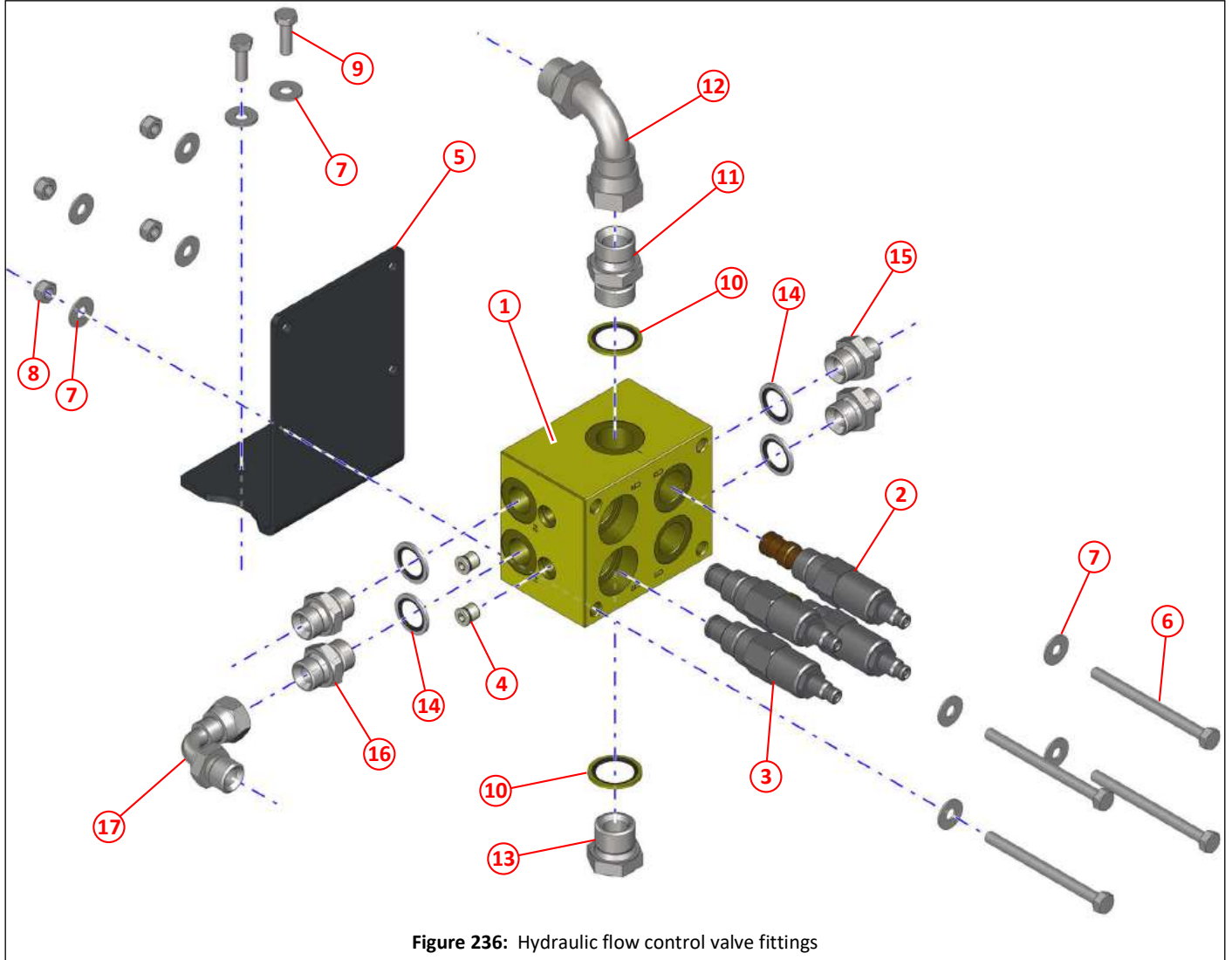

Figure 236: Hydraulic flow control valve fittings

Item	Part No	Qty	Description	
①	038513	1	Flow control, remote mounted, assembly, includes items ②, ③ and ④	271,375
②	040288	2	Flow regulator (PFR2-10-S-0-9.00)	
③	039063	2	Relief valve (RV5-10-S-0-35/30)	
④	039061	2	Hex plug, hollow, 1/4" SAE	
⑤	046973	1	Bracket, flow control, remote mounted	
⑥	011020	4	Bolt, M8 x 80	
⑦	011092	10	Washer M8	
⑧	011073	4	Nyloc nut T M8	
⑨	011011	2	Setscrew M8 x 25	
⑩	011155	2	Dowty seal 3/4" BSP	
⑪	011161	1	Adapter, male/male, 3/4" BSP	
⑫	011196	1	Elbow, swept 90°, male/female, 3/4" BSP	
⑬	011244	1	Plug 3/4" BSP	
⑭	011154	4	Dowty seal 3/4" BSP	
⑮	011167	2	Adapter 1/2" x 3/8" BSP	
⑯	011160	2	Adapter 1/2" BSP, male/male	
⑰	011176	1	Elbow, sweep, 1/2" BSP	

Hydraulic high pressure oil filters

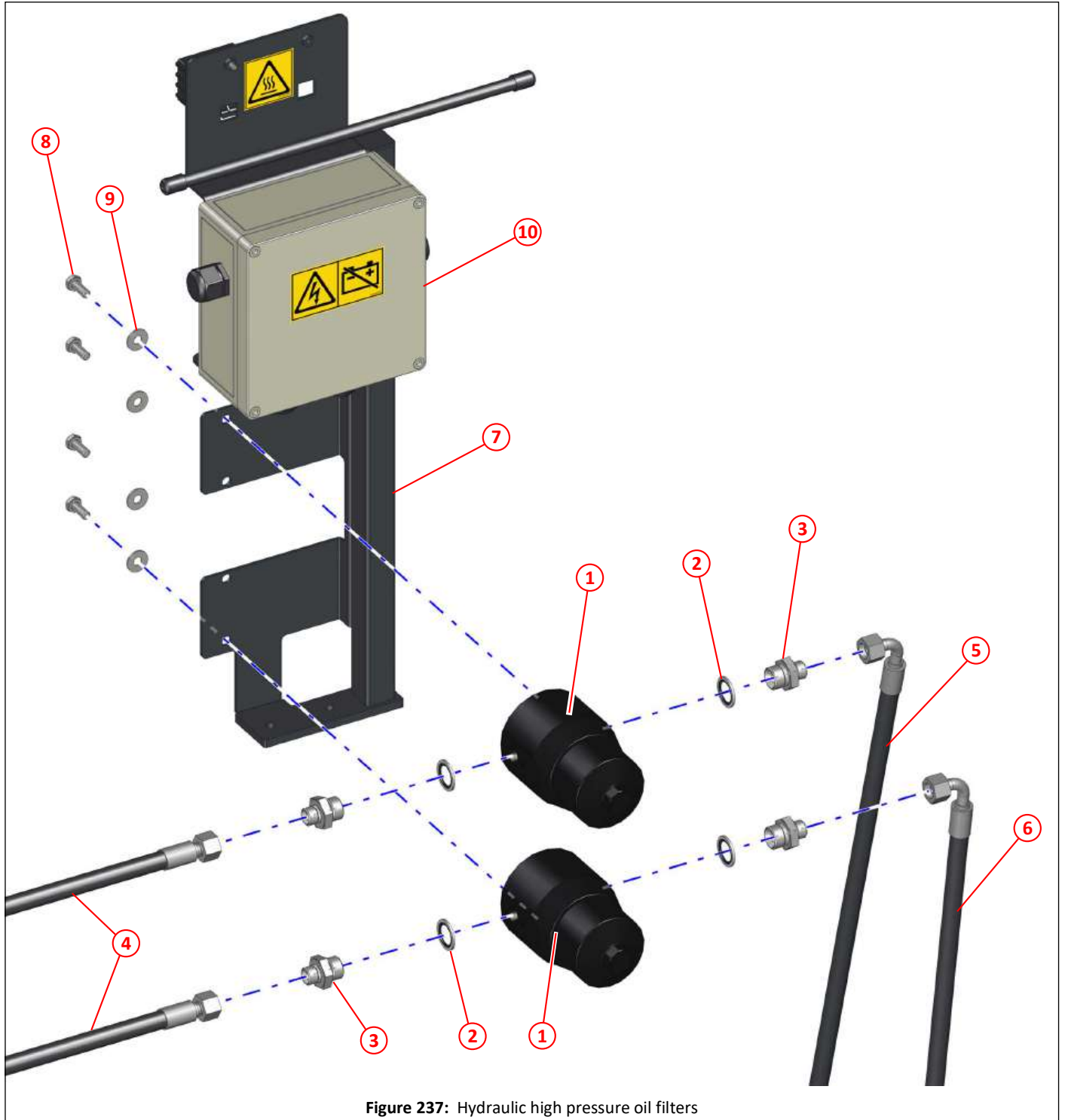

Figure 237: Hydraulic high pressure oil filters

Item	Part No	Qty	Description	
①	025103	2	Filter high pressure	
②	011154	4	Dowty seal $\frac{3}{4}$ " BSP	
③	011167	4	Adapter $\frac{1}{2}$ " x $\frac{3}{8}$ " BSP	
④	001360	2	Hose $\frac{3}{8}$ " x 940, straight and 90° ends	
⑤	001162	1	Hose $\frac{3}{8}$ " x 1150, straight and 90° ends, to Port P on Options valve block	
⑥	001164	1	Hose $\frac{3}{8}$ " x 1400, straight and 90° ends, to Port P on Main valve block	280
⑦	042957	1	Junction box, mount	
⑧	011010	4	Setscrew M8 x 20	
⑨	011092	4	Washer M8	
⑩	043350	1	Battery junction box for DEUTZ	

Hydraulic fan and suction nozzle tilt control valve block, coils and solenoids

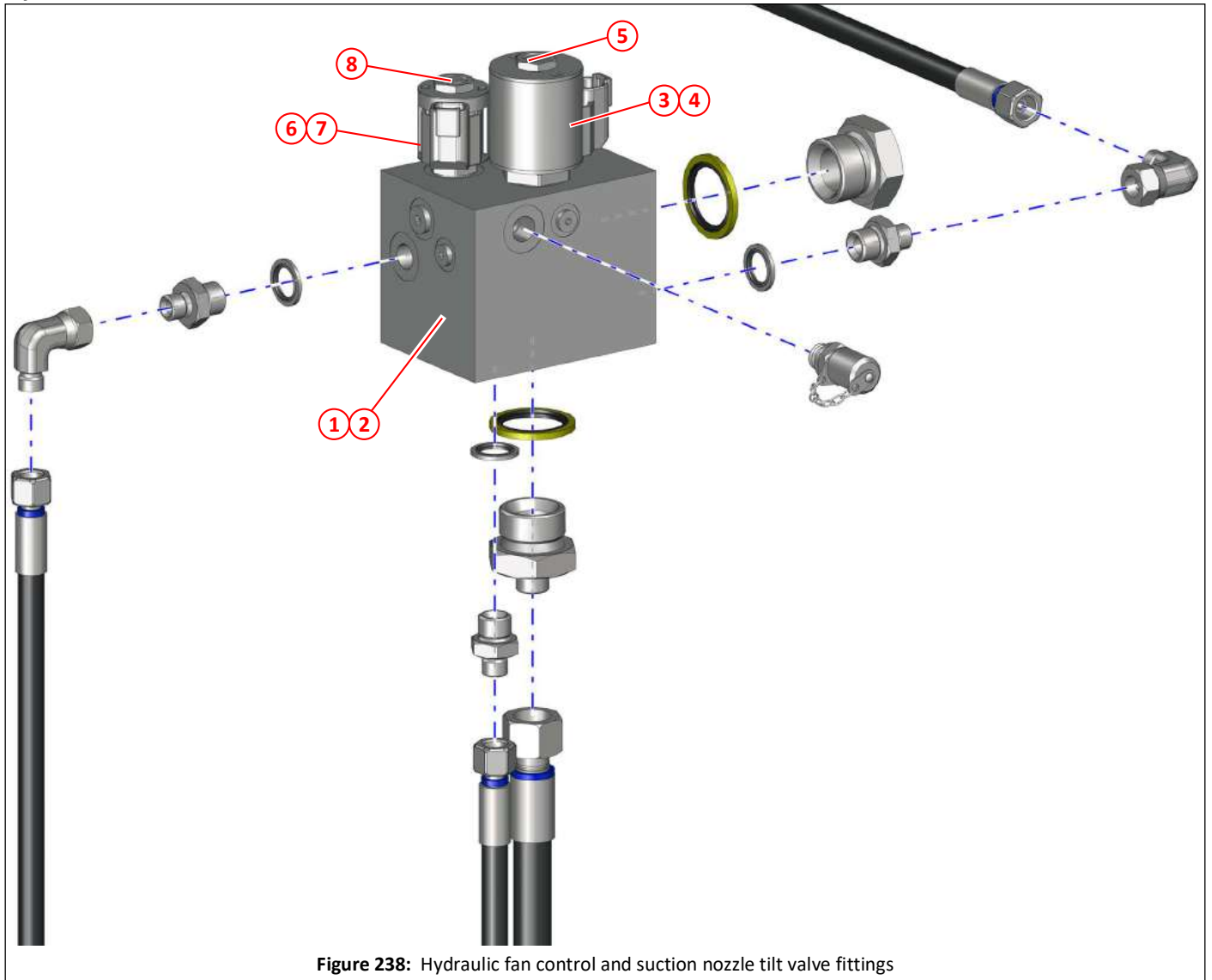

Figure 238: Hydraulic fan control and suction nozzle tilt valve fittings

Item	Part No	Qty	Description
①	048012	1	Manifold, fan drive, nozzle tilt 12V, includes items ③, ⑤ and ⑥
②	047751	1	Manifold, fan drive, nozzle tilt 24V, includes items ④, ⑤ and ⑦
③	041224	1	Coil, 4304112 E SERIES, 12V
④	044048	1	Coil, 4304124 E SERIES, 24V
⑤	044499	1	Solenoid SV58-30-0-P-00
⑥	041225	1	Coil, 4304012 E SERIES, 12V
⑦	044049	1	Coil, 4304024 E SERIES, 24V
⑧	048478		Solenoid SF08-22-0-P-00

Hydraulic fan and suction nozzle tilt control valve block, hoses and fittings

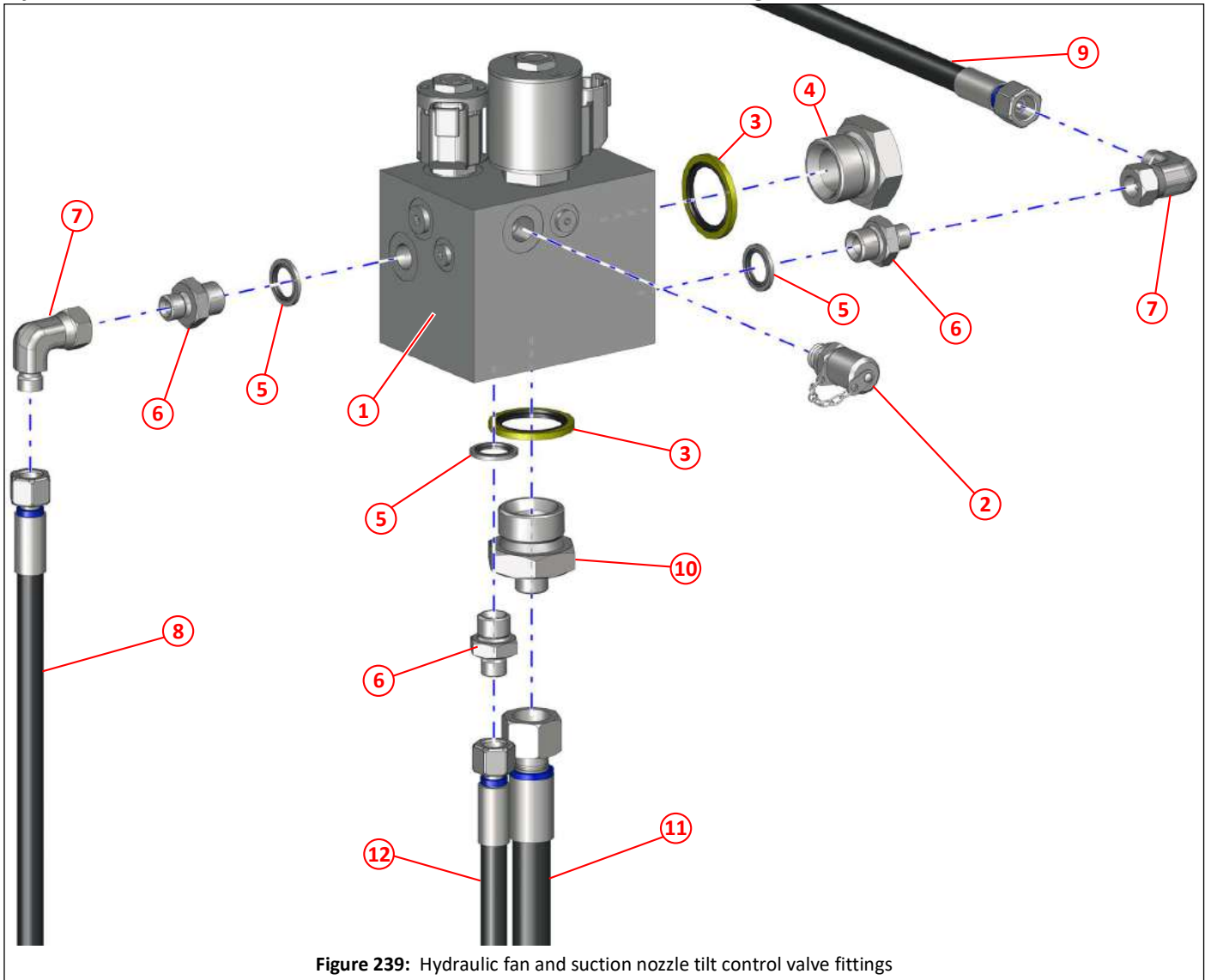

Figure 239: Hydraulic fan and suction nozzle tilt control valve fittings

Item	Part No	Qty	Description	
①		1	Manifold, fan drive, nozzle tilt	274
②	013036	1	Test point, $\frac{1}{4}$ " BSP	
③	011156	2	Dowty seal 1" BSP	
④	011136	1	Plug 1" BSP	
⑤	011153	3	Dowty seal $\frac{3}{8}$ " BSP	
⑥	011199	3	Adapter $\frac{3}{8}$ " x $\frac{1}{4}$ " BSP	
⑦	011171	2	Elbow, swivel $\frac{1}{4}$ " BSP, male/female	
⑧	001287	1	Hose $\frac{1}{4}$ " x 715, straight and 90° ends	
⑨	001104	1	Hose $\frac{1}{4}$ " x 1020, straight and 90° ends	
⑩	002294	1	Adapter 1" BSP x $\frac{3}{8}$ " BSP male/male	
⑪	001076	1	Hose $\frac{1}{2}$ " x 600, straight and 90° ends	
⑫	001367	1	Hose $\frac{1}{4}$ " x 2220, straight end and 90° stand pipe 6mm end	

Main and option valve blocks in hydraulic cabinet

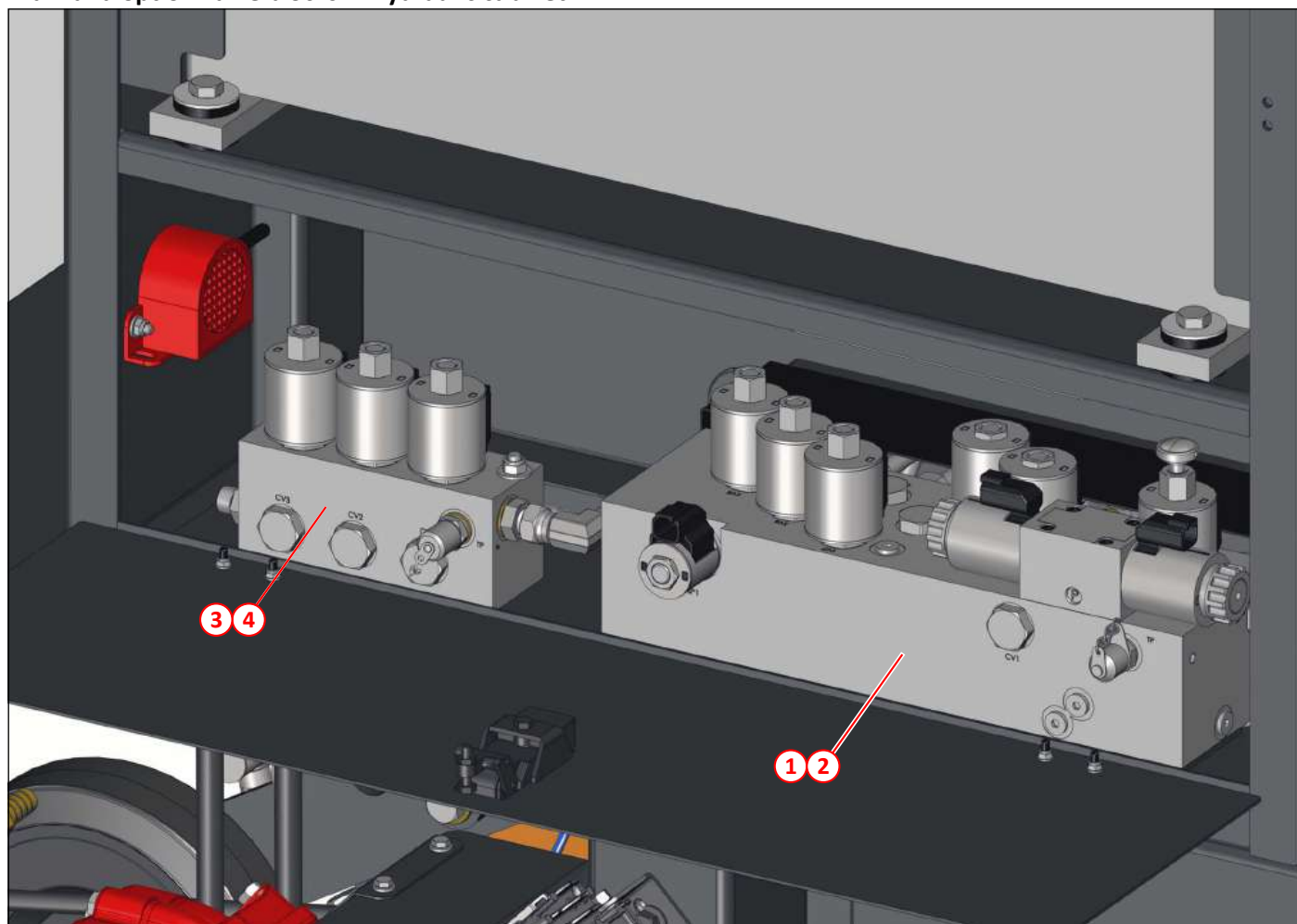
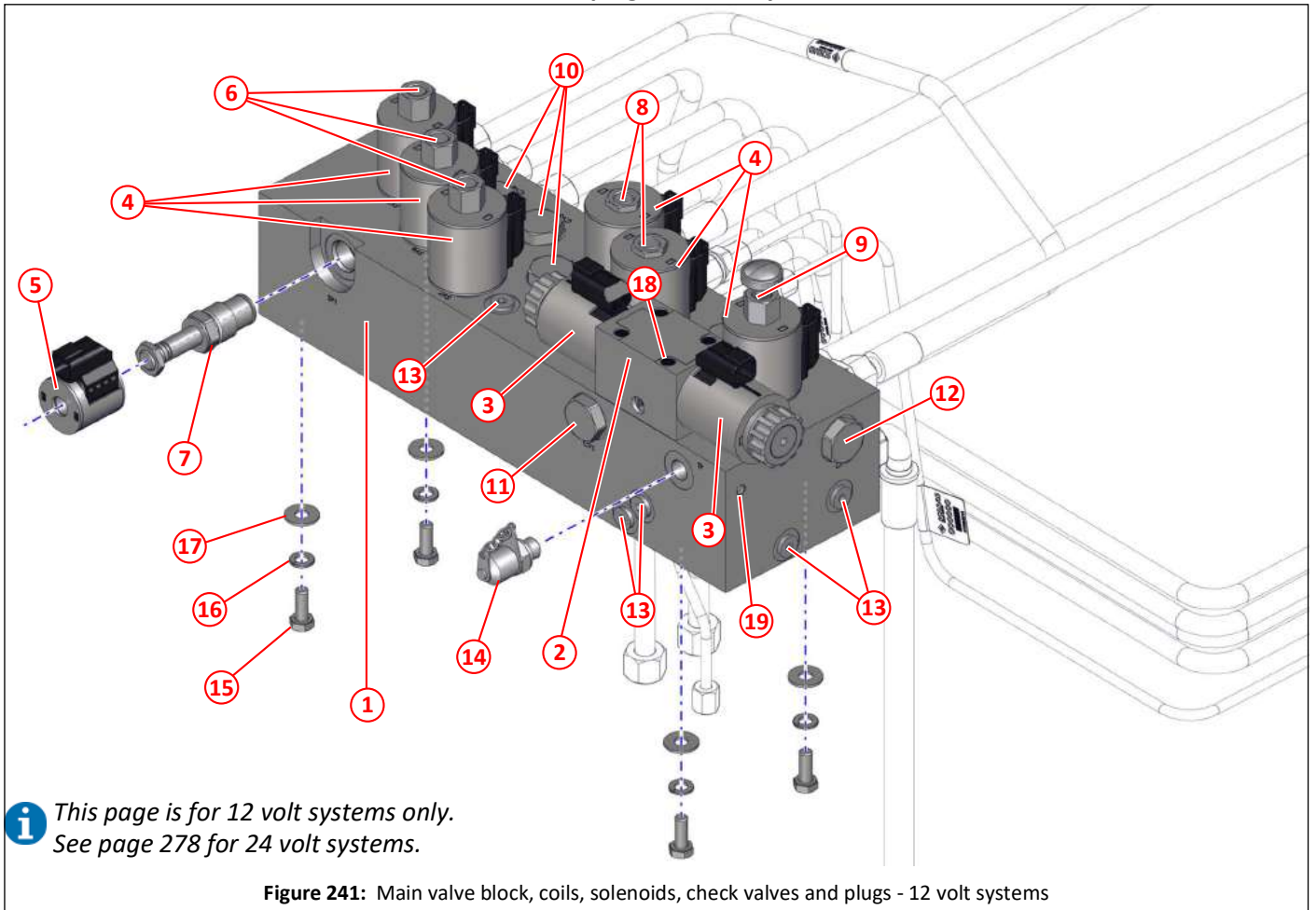

Figure 240: Main and option valve block in hydraulic cabinet

Item	Part No	Qty	Description
①	044485	1	Main valve block assembly, populated, 12V
②	043393	1	Main valve block assembly, populated, 24V
③	044487	1	Option valve block assembly, populated, 12V
④	043394	1	Option valve block assembly, populated, 24V

Main valve block, coils, solenoids, check valves and plugs - 12 volt systems



i This page is for 12 volt systems only.
See page 278 for 24 volt systems.

Figure 241: Main valve block, coils, solenoids, check valves and plugs - 12 volt systems

Item	Part No	Qty	Description
①	044045	1	Main valve block, bare
②	044046	1	Directional control valve, SVD03-47C-N-00
③	044497	2	Coil 12V, E Series, 4302692
④	041224	6	Coil 12V, E Series, 4304112
⑤	041225	1	Coil 12V, E Series, 4304012
⑥	044053	3	Solenoid valve, SV10-21-0-N-00
⑦	044051	1	Solenoid valve, SP08-20-0-N-00
⑧	044052	2	Solenoid valve, SV10-20-0-N-00
⑨	044054	1	Solenoid valve, manual override, SV10-21K-0-N-00
⑩	044055	3	Cartridge check valve, CV10-20-0-N-100
⑪	045534	1	Cartridge check valve, CV10-20-0-N-05
⑫	044056	1	Cavity plug, CP10-20-N
⑬	044058	15	SAE plug, 6103004
⑭	013036	1	Test point adapter
⑮	011010	4	Setscrew HT M8 x 20
⑯	011093	4	Spring washer M8
⑰	011092	4	Washer M8
⑱	044050	4	Cap head bolt, directional control valve, 4190021
⑲	044059	1	Expander plug

i Please see 'Resistors for hydraulic coils, 12V' on page 349 for resistor usage on some of these coils.

Main valve block, coils, solenoids, check valves and plugs - 24 volt systems

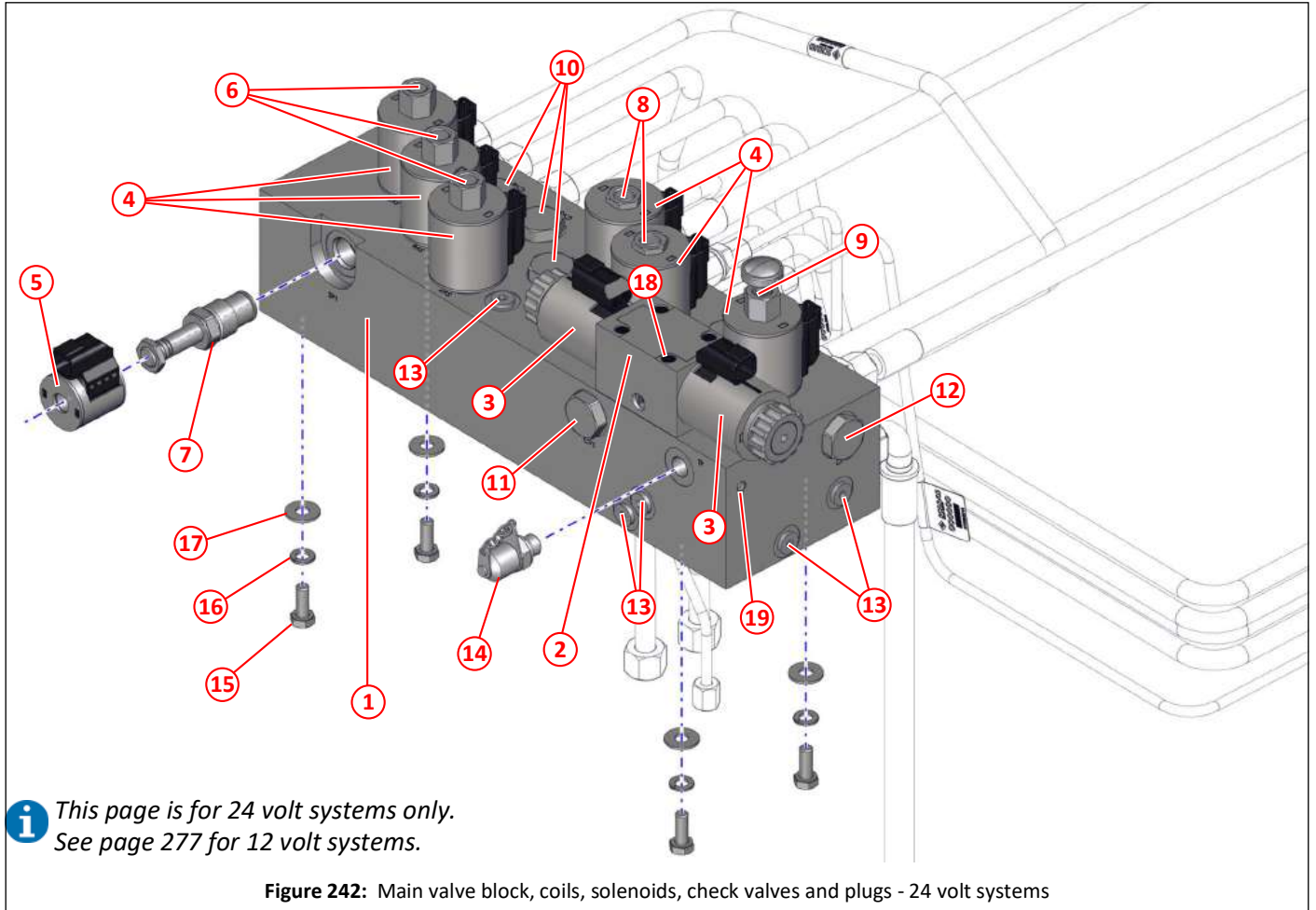

Figure 242: Main valve block, coils, solenoids, check valves and plugs - 24 volt systems

Item	Part No	Qty	Description
①	044045	1	Main valve block, bare
②	044046	1	Directional control valve, SVD03-47C-N-00
③	044047	2	Coil 24V, E Series, 4302694
④	044048	6	Coil 24V, E Series, 4304124
⑤	044049	1	Coil 24V, E Series, 4304024
⑥	044053	3	Solenoid valve, SV10-21-0-N-00
⑦	044051	1	Solenoid valve, SP08-20-0-N-00
⑧	044052	2	Solenoid valve, SV10-20-0-N-00
⑨	044054	1	Solenoid valve, manual override, SV10-21K-0-N-00
⑩	044055	3	Cartridge check valve, CV10-20-0-N-100
⑪	045534	1	Cartridge check valve, CV10-20-0-N-05
⑫	044056	1	Cavity plug, CP10-20-N
⑬	044058	15	SAE plug, 6103004
⑭	013036	1	Test point adapter
⑮	011010	4	Setscrew HT M8 x 20
⑯	011093	4	Spring washer M8
⑰	011092	4	Washer M8
⑱	044050	4	Cap head bolt, directional control valve, 4190021
⑲	044059	1	Expander plug

Main valve block, fittings

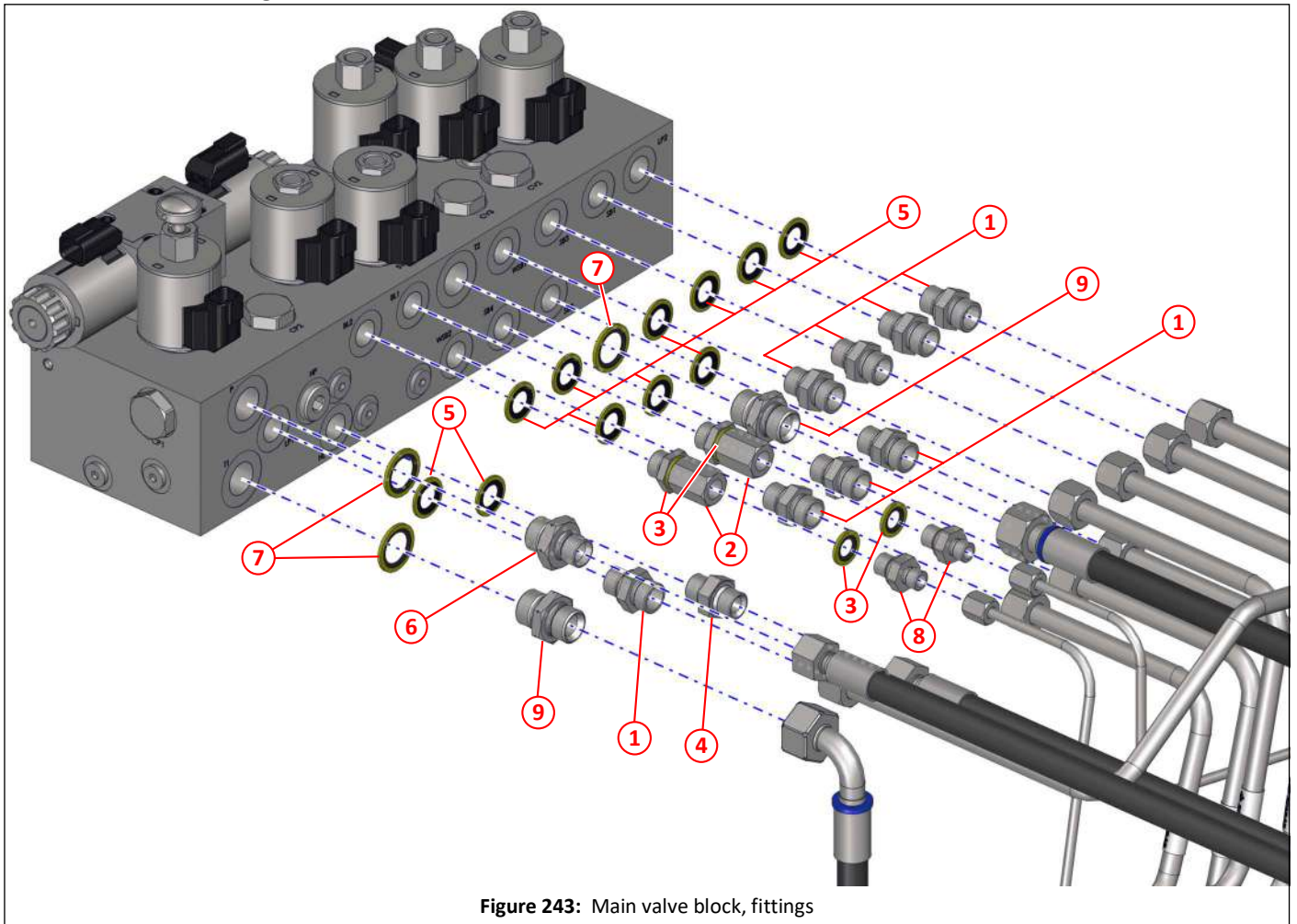

Figure 243: Main valve block, fittings

Item	Part No	Qty	Description
①	002175	8	Male stud 12L to M16 x 1.5
②	002176	2	Adapter, M/F, M16 x 1.5 to 1/4" BSP, 2 parts (adapter M/M and adapter F/F)
③	011152	4	Dowty seal 1/4" BSP
④	011186	1	Adapter M16 x 1.5 to 3/8" BSP
⑤	011217	11	Dowty seal M16
⑥	011266	1	Adapter M20 x 1.5 to 3/8" BSP
⑦	011267	3	Dowty seal M20
⑧	020902	2	Male stud 6L x 1/4" BSP
⑨	037741	2	Adapter 1/2" BSP male to M20 x 1.5 male

Main valve block, pipes and hoses

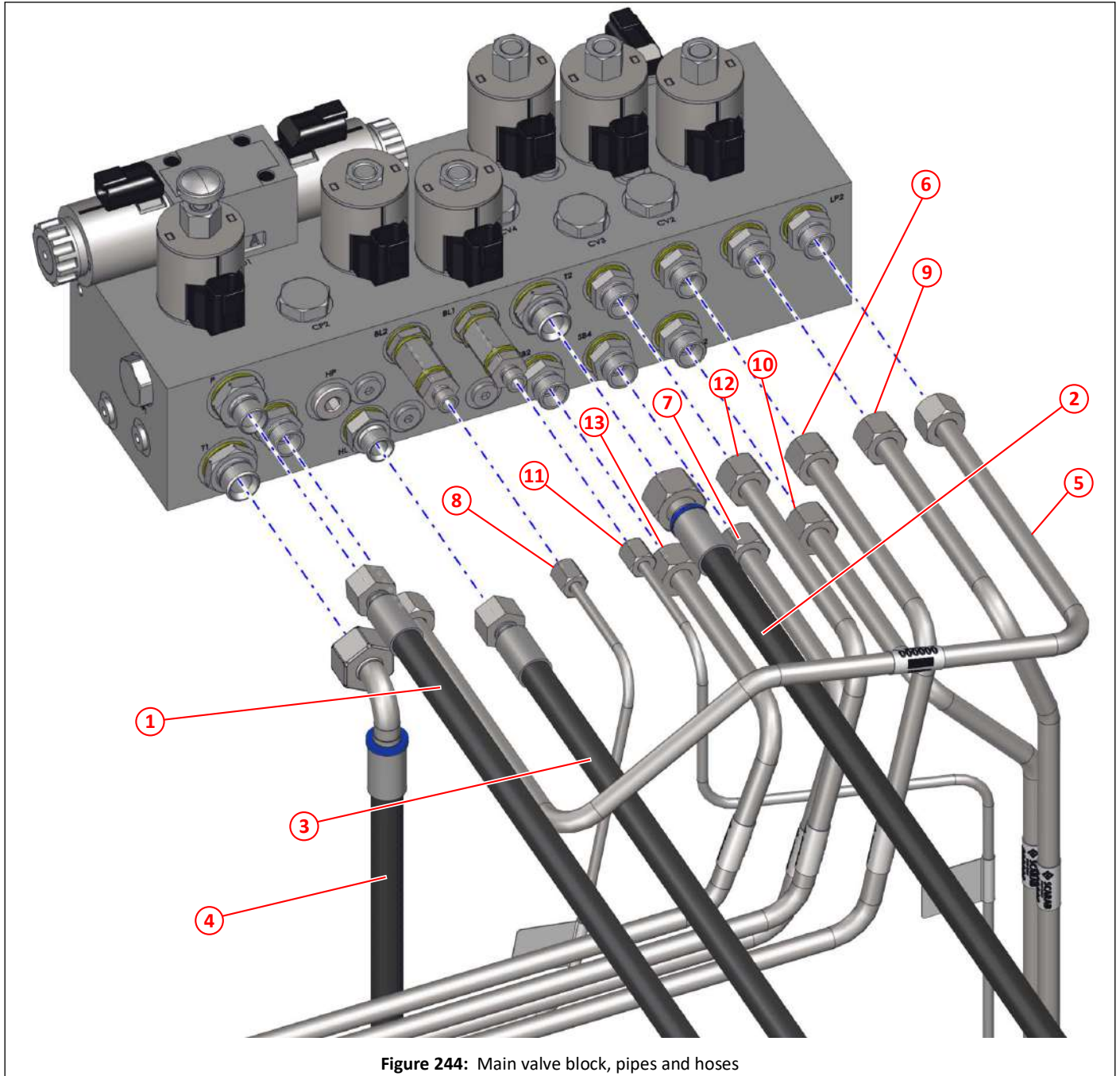
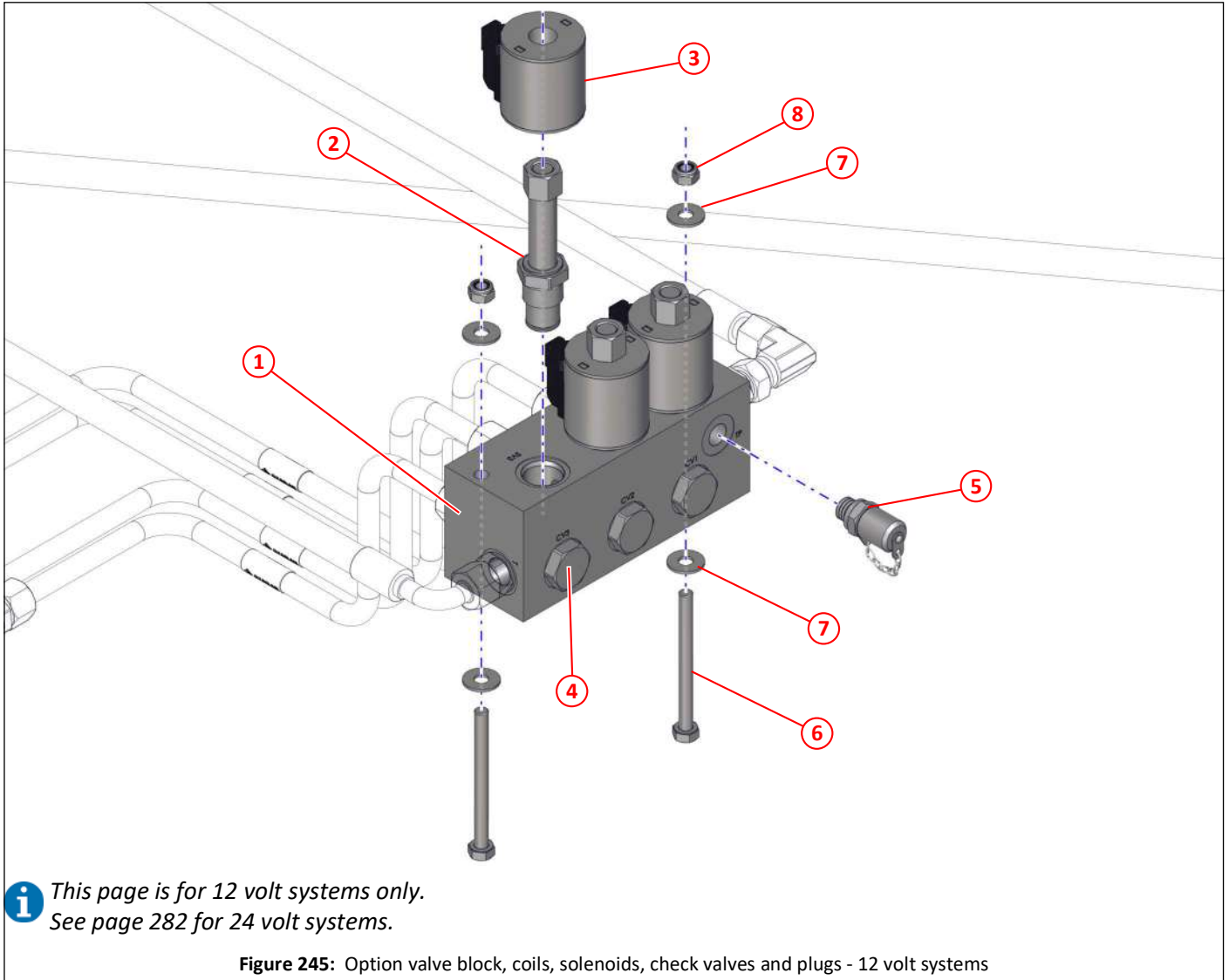

Figure 244: Main valve block, pipes and hoses

Item	Part No	Qty	Description	
①	001164	1	Hose $\frac{3}{8}$ " x 1400, straight and 90° ends, from oil filter	273
②	001328	1	Hose $\frac{1}{2}$ " x 810, straight/90°, to oil cooler	416
③	011311	1	Hose $\frac{3}{8}$ " x 1100, straight/90°, from hand pump/hopper control valves	
④	030992	1	Hose $\frac{1}{2}$ " x 1100, straight/90°, to oil cooler	416
⑤	040127	1	Link pipe, steel, LP1/LP2	
⑥	043405	1	Pipe, steel, left hand brush feed, part 1	
⑦	043407	1	Pipe, steel, left hand brush return, part 1	
⑧	043409	1	Pipe, steel, left hand brush lift, part 1	
⑨	043412	1	Pipe, steel, right hand brush feed	
⑩	043413	1	Pipe, steel, right hand brush return	
⑪	043414	1	Pipe, steel, right hand brush lift	
⑫	043416	1	Pipe, steel, central (wide sweep) brush feed, part 1	
⑬	043418	1	Pipe, steel, central (wide sweep) brush return, part 1	

Option valve block, coils, solenoids, check valves and plugs - 12 volt systems



Item	Part No	Qty	Description
①	044486	1	Options valve block assembly, populated with ②, ③ and ④, 12V
②	044053	3	Solenoid valve, SV10-21-0-N-00
③	041224	3	Coil 12V, E Series, 4304112
④	044055	3	Cartridge check valve, CV10-20-0-N-100
⑤	013036	1	Test point adapter
⑥	011019	2	Bolt M8 x 90
⑦	011092	4	Washer M8
⑧	011073	2	Nyloc nut T M8

i Please see 'Resistors for hydraulic coils, 12V 'on page 349 for resistor usage on some of these coils.

Option valve block, coils, solenoids, check valves and plugs - 24 volt systems

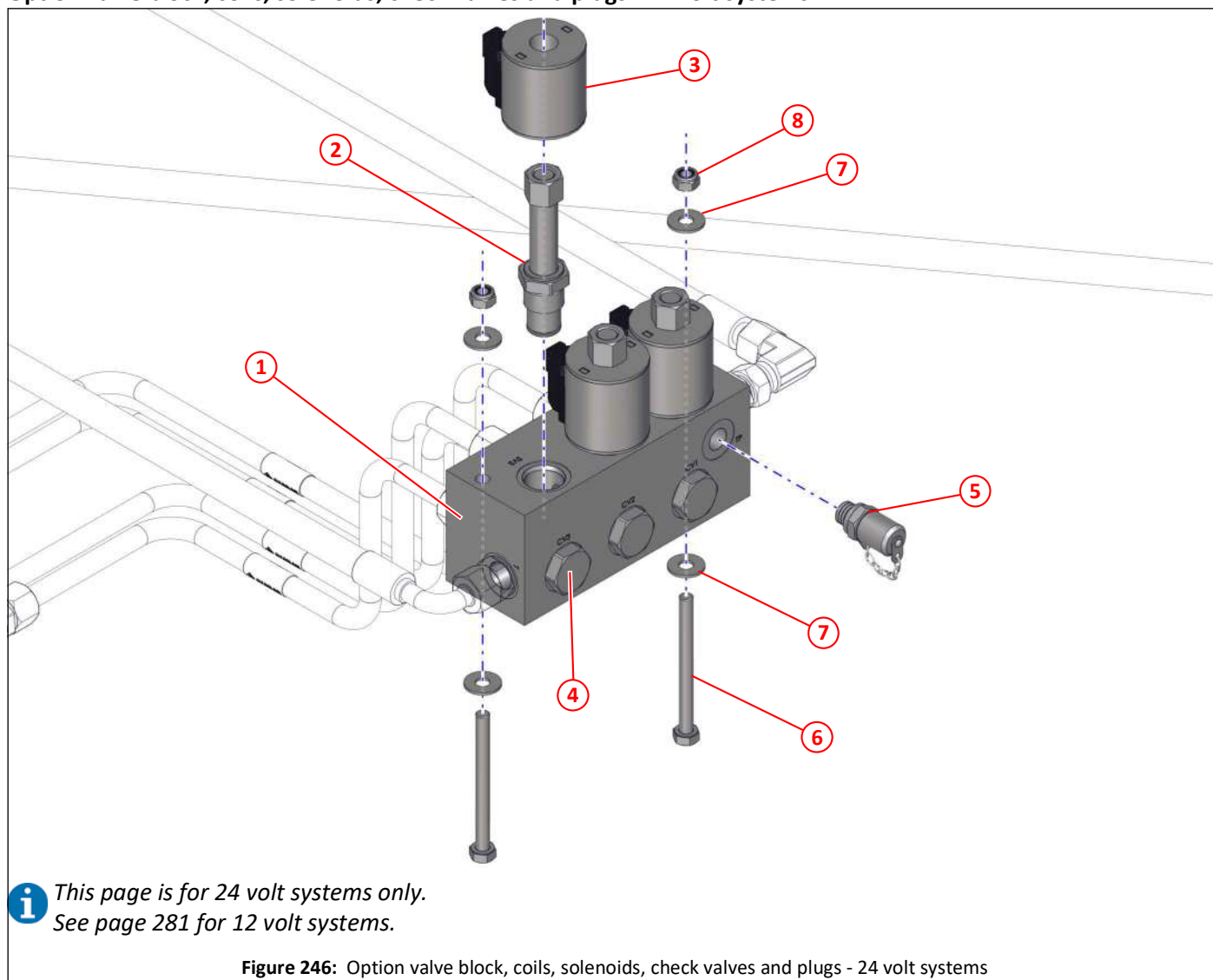

i This page is for 24 volt systems only.
See page 281 for 12 volt systems.

Figure 246: Option valve block, coils, solenoids, check valves and plugs - 24 volt systems

Item	Part No	Qty	Description
①	042616	1	Options valve block assembly, populated with ②, ③ and ④, 24V
②	044053	3	Solenoid valve, SV10-21-0-N-00
③	044048	3	Coil 24V, E Series, 4304124
④	044055	3	Cartridge check valve, CV10-20-0-N-100
⑤	013036	1	Test point adapter
⑥	011019	2	Bolt M8 x 90
⑦	011092	4	Washer M8
⑧	011073	2	Nyloc nut T M8

Option valve block, fittings

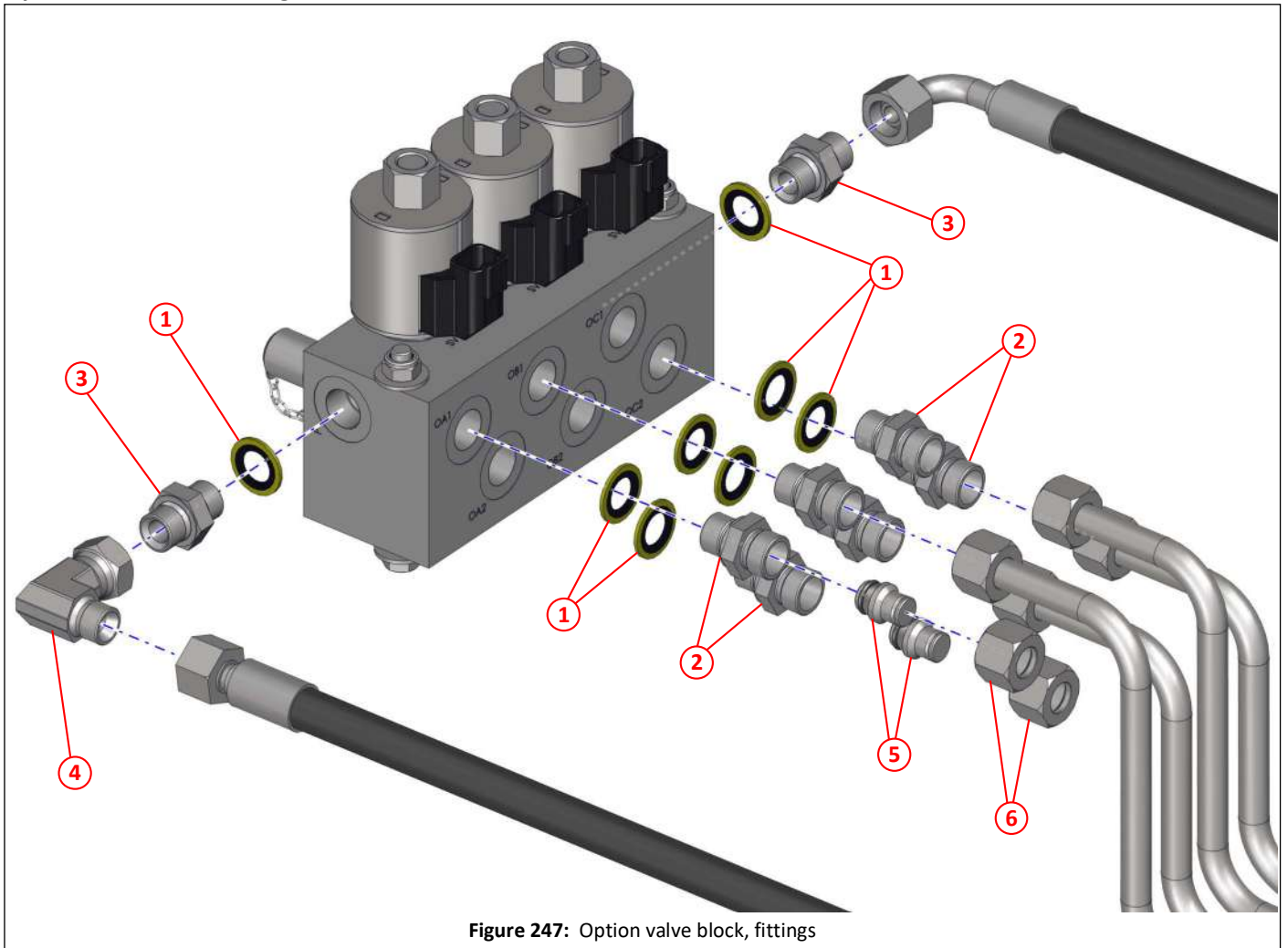

Figure 247: Option valve block, fittings

Item	Part No	Qty	Description
①	011217	8	Dowty seal M16
②	002175	6	Male stud M16 x 1.5 x 12
③	011186	2	Adapter M16 x 1.5 x $\frac{3}{8}$ " BSP
④	011172	1	Elbow, swivel, $\frac{3}{8}$ " BSP, male/female
⑤	002236	2	Blanking plug 12mm
⑥	002130	2	Compression nut 12mm

Option valve block, pipes and hoses

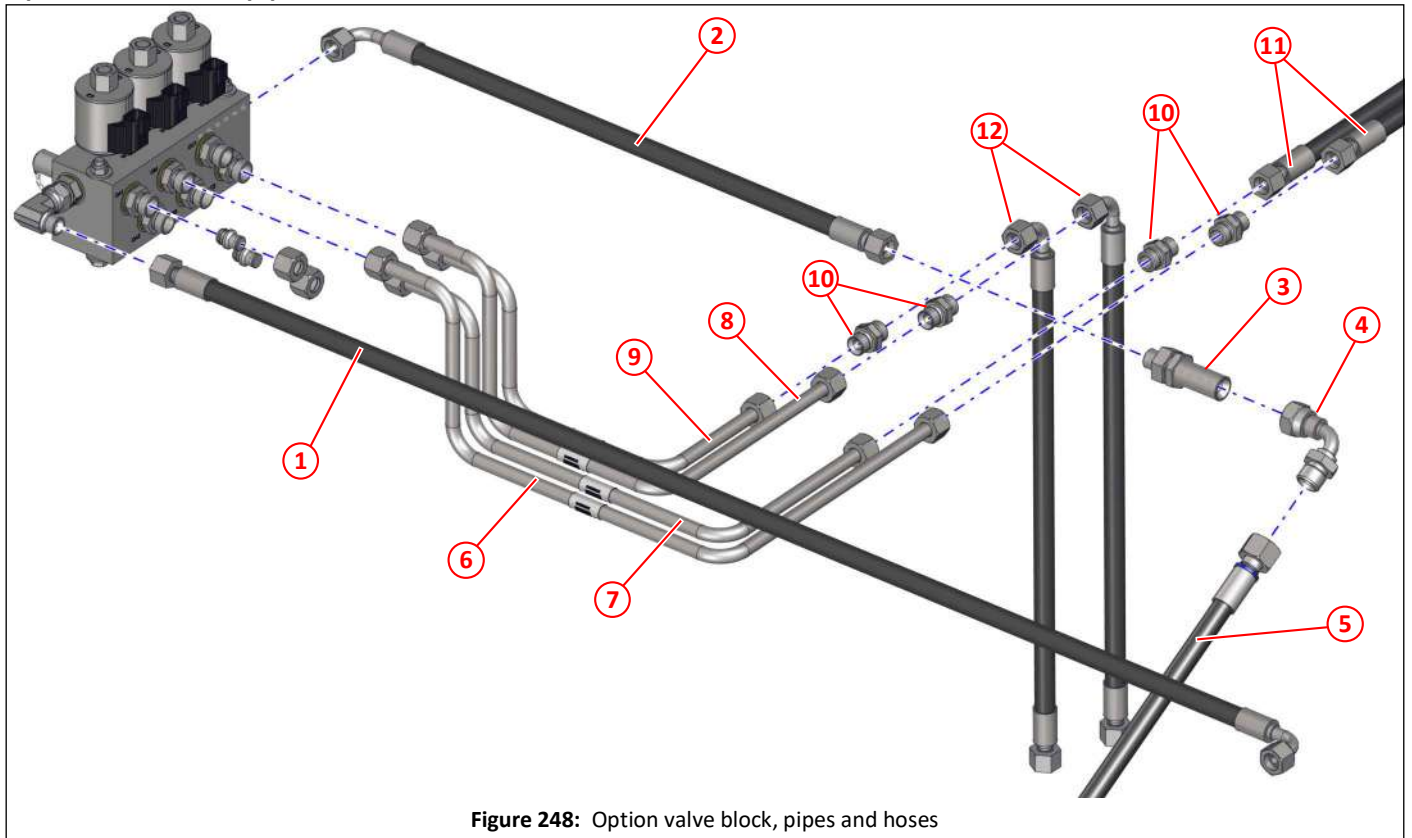

Figure 248: Option valve block, pipes and hoses

Item	Part No	Qty	Description
①	001162	1	Hose $\frac{3}{8}$ " x 1150, straight and 90° ends, from HP oil filter to Port P
②	001226	1	Hose $\frac{3}{8}$ " x 530, straight and 90° ends, from Port T to tank return
③	002255	1	Bulkhead adapter, extended, $\frac{3}{8}$ " x $\frac{1}{2}$ " BSP, complete with nut
④	011176	1	Sweep elbow $\frac{1}{2}$ " BSP
⑤	001345	1	Hose $\frac{1}{2}$ " x 2900, straight and 90° ends, to tank return
⑥	043401	1	Steel pipe, high pressure water pump, feed
⑦	043402	1	Steel pipe, high pressure water pump, return
⑧	043399	1	Steel pipe, low pressure water pump, feed
⑨	043400	1	Steel pipe, low pressure water pump, return
⑩	020903	4	Male stud 12 x $\frac{3}{8}$ " BSP
⑪	001149	2	Hose $\frac{3}{8}$ " x 3550, straight and 90° ends, high pressure water pump
⑫	001294	2	Hose $\frac{3}{8}$ " x 500, straight and 90° ends, low pressure water pump

Hopper and subframe hydraulics

Hopper and rear door control valve

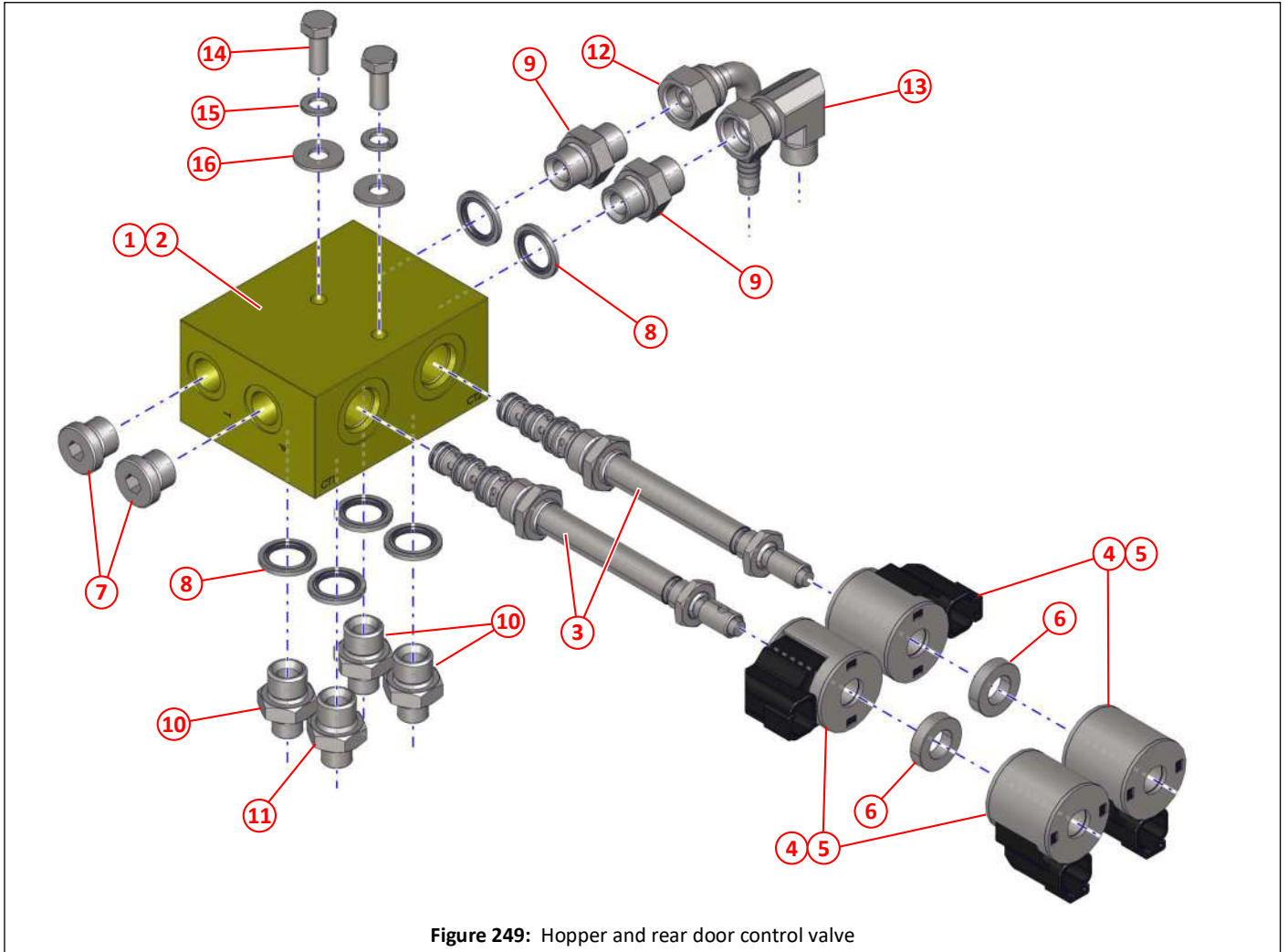

Figure 249: Hopper and rear door control valve

Item	Part No	Qty	Description
①	044491	1	Hopper control valve, 12V, includes items ③, ④ and ⑥
②	039703	1	Hopper control valve, 24V, includes items ③, ⑤ and ⑥
③	039746	2	Solenoid valve
④	041225	4	Coil, 12V / 17.2 WATTS-ELZ
⑤	039747	4	Coil, 24V with diode
⑥	039748	2	Coil spacer
⑦	035242	2	Port plug $\frac{3}{8}$ " BSP
⑧	011153	6	Dowty seal $\frac{3}{8}$ " BSP
⑨	011159	2	Adapter $\frac{3}{8}$ " BSP
⑩	011199	3	Adapter $\frac{3}{8}$ " x $\frac{1}{4}$ " BSP
⑪	040217	1	Restrictor $\frac{1}{4}$ " x $\frac{3}{8}$ " BSP $\frac{3}{64}$ " ORANGE
⑫	002048	1	Elbow, swept, hosetail, $\frac{3}{8}$ " BSPF $\frac{3}{8}$ " hose
⑬	011172	1	Elbow, swivel $\frac{3}{8}$ " BSP M/F
⑭	011010	2	Setscrew HT M8 X 20
⑮	011093	2	Spring washer M8
⑯	011092	2	Washer M8

Hopper and rear door control valve - hoses

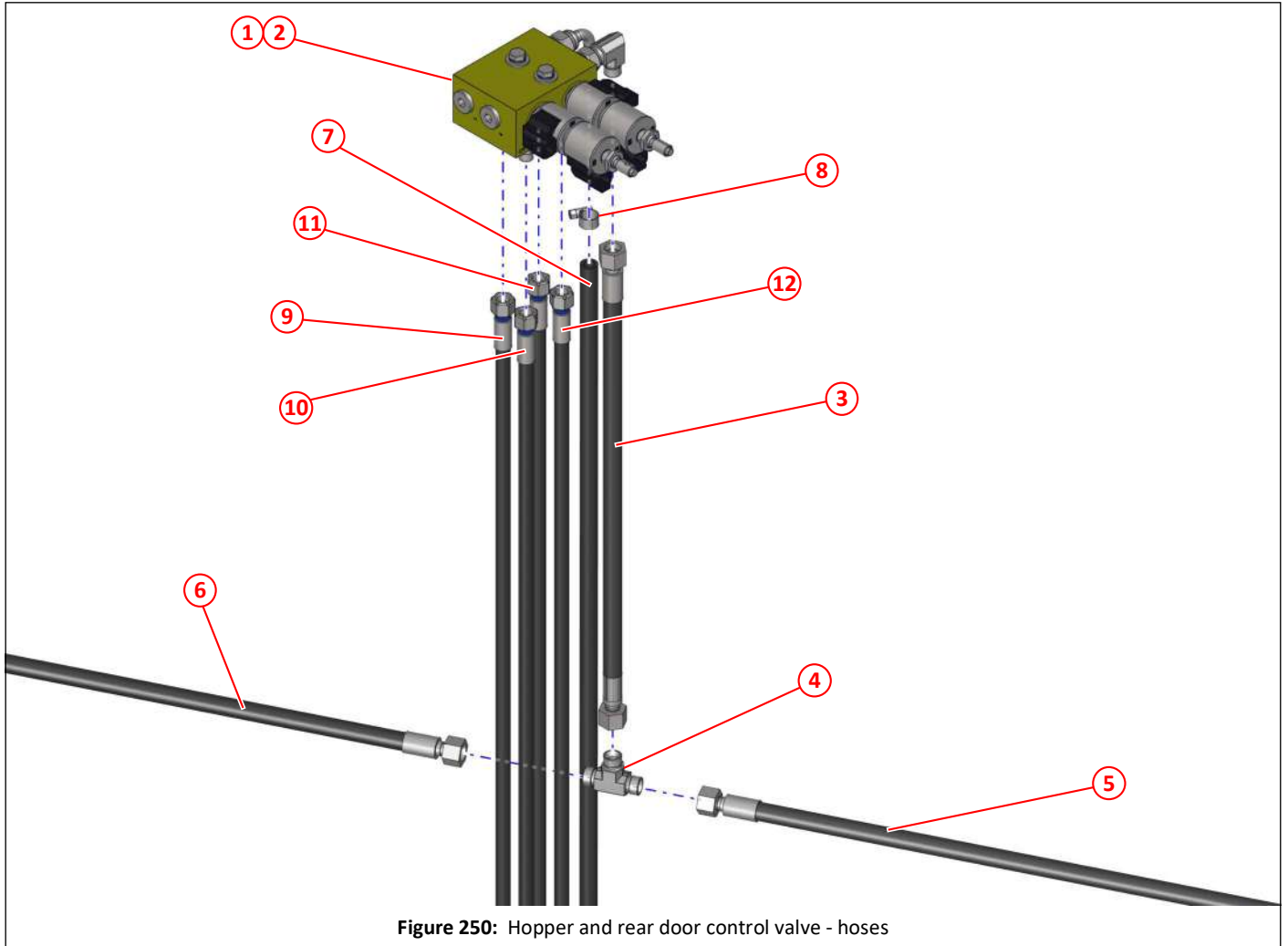

Figure 250: Hopper and rear door control valve - hoses

Item	Part No	Qty	Description	
①	044491	1	Hopper control valve, 12V	285
②	039703	1	Hopper control valve, 24V	285
③	011308	1	Hose $\frac{3}{8}$ " x 500, Port P to hand pump/main valve block Port HL	
④	011198	1	Tee $\frac{3}{8}$ " BSP, male/male/male	
⑤	011344	1	Hose $\frac{3}{8}$ " x 2100, from main valve block Port HL	
⑥	001023	1	Hose $\frac{3}{8}$ " x 710, straight and 90° ends, to hand pump	
⑦	010958	1	Hose $\frac{3}{8}$ ", cut to length as required, return to tank	
⑧	010516	1	Jubilee clip No. MOO [ø11 - ø16]	
⑨	001036	1	Hose $\frac{1}{4}$ " x 4100, Port A to hopper door ram close	
⑩	001036	1	Hose $\frac{1}{4}$ " x 4100, Port B to hopper door ram open	
⑪	011329	1	Hose $\frac{1}{4}$ " x 1200, Port C to hopper lift ram lower	
⑫	011329	1	Hose $\frac{1}{4}$ " x 1200, Port D to hopper lift ram raise	

Hydraulic hand pump

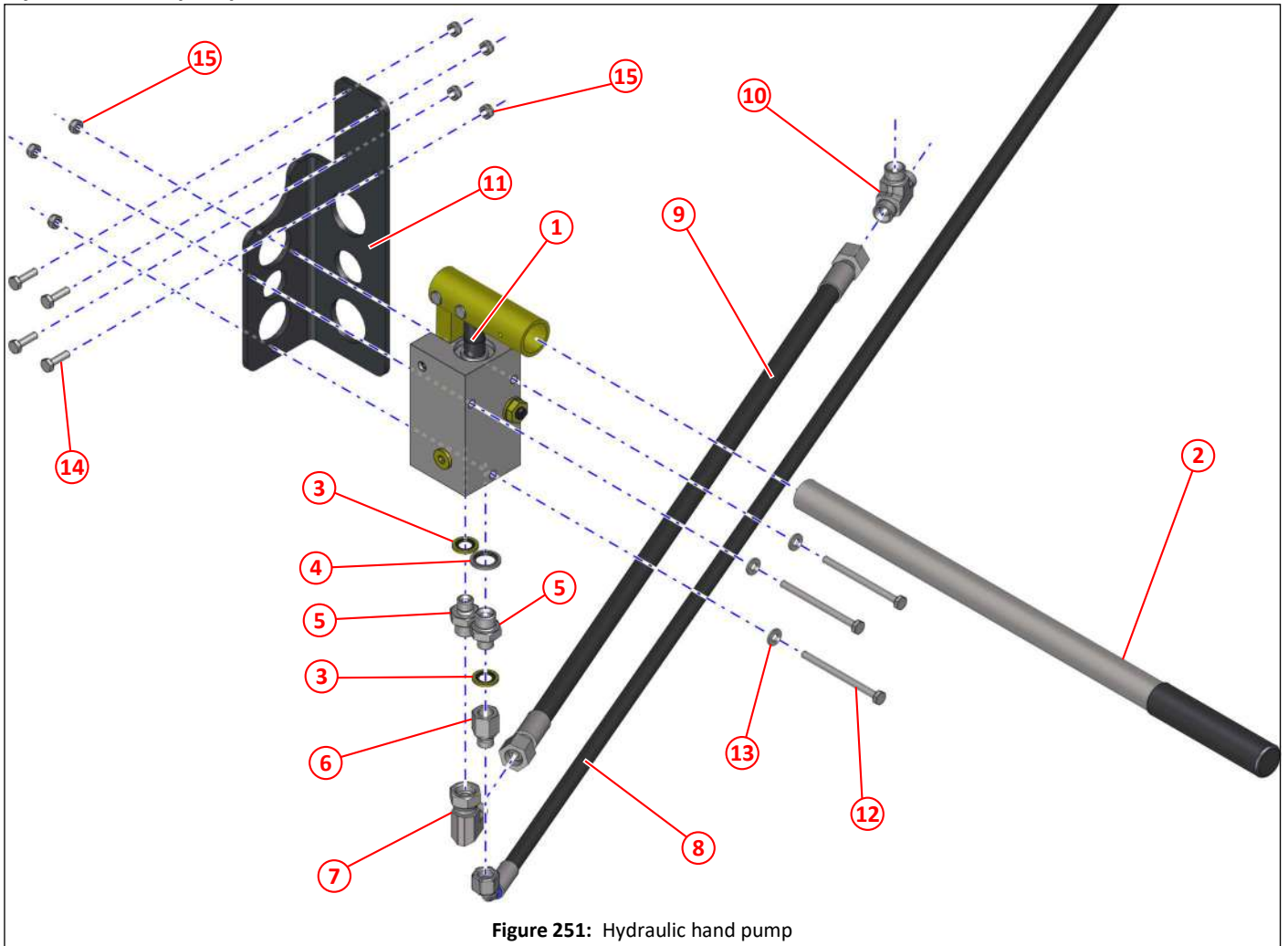

Figure 251: Hydraulic hand pump

Item	Part No	Qty	Description
①	023006	1	Hydraulic hand pump
②	038657	1	Handle
③	011152	2	Dowty seal $\frac{1}{4}$ " BSP
④	011153	1	Dowty seal $\frac{3}{8}$ " BSP
⑤	011199	2	Adapter $\frac{3}{8}$ " x $\frac{1}{4}$ " BSP
⑥	002014	1	Adapter, fixed, $\frac{1}{4}$ " BSP male/female
⑦	011172	1	Elbow, swivel $\frac{3}{8}$ " BSP M/F
⑧	001106	1	Hose $\frac{1}{4}$ " x 1820, straight and 90° ends, Port T to tank return
⑨	001023	1	Hose $\frac{3}{8}$ " x 710, straight and 90° ends, Port P to hopper control valve
⑩	011198	1	Tee $\frac{3}{8}$ " BSP, male/male/male
⑪	038257	1	Bracket, hand pump
⑫	000221	3	Bolt M6 x 80
⑬	011090	3	Washer M6
⑭	011067	4	Setscrew HT M6 x 20
⑮	011071	7	Nyloc nut R M6

Hopper lift ram

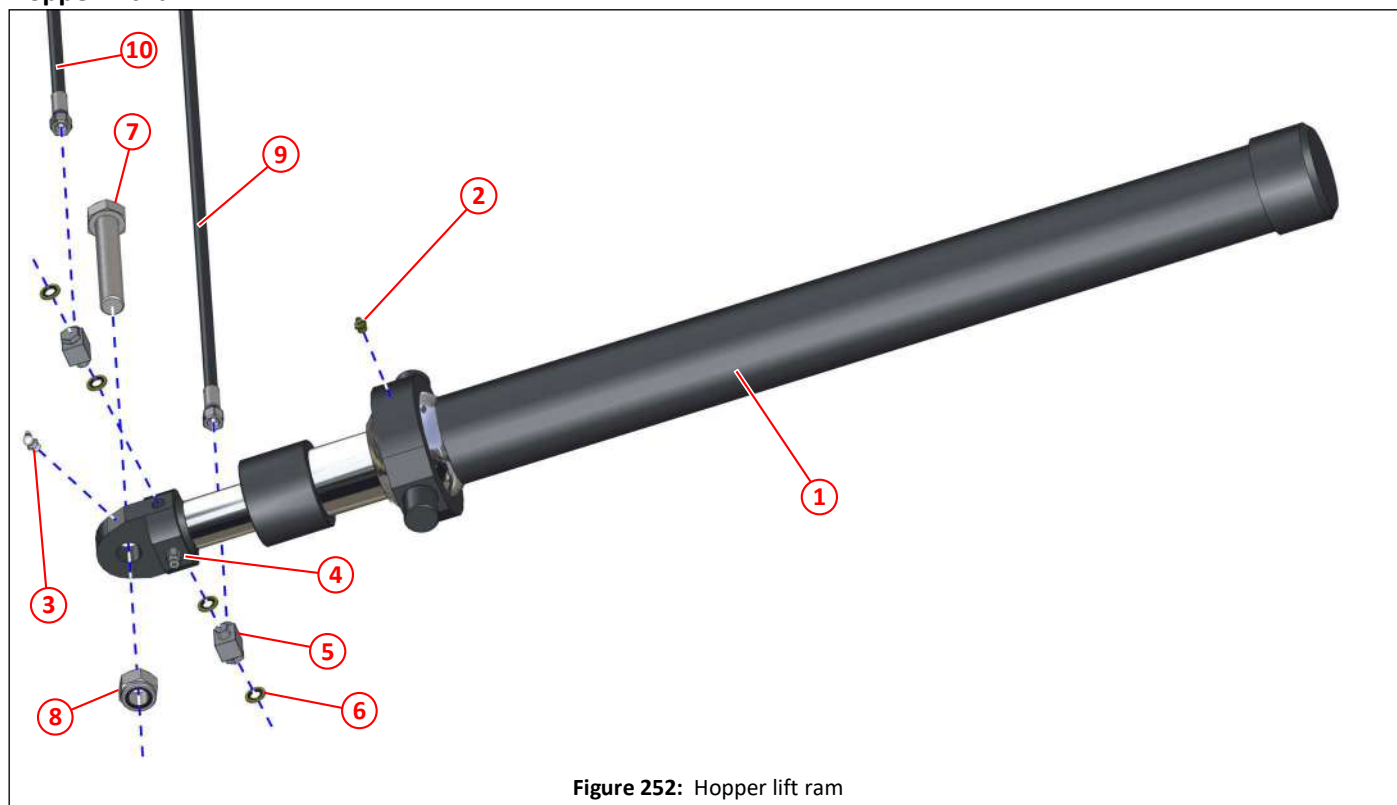

Figure 252: Hopper lift ram

Item	Part No	Qty	Description
①	024249	1	Ram, dual acting, hopper lift
②	010903	1	Grease nipple $\frac{1}{8}$ " BSP straight
③	010902	1	Grease nipple $\frac{1}{8}$ " BSP 90°
④	028178	2	Check valve 1CE 30F35S5
⑤	002017	2	Banjo adapter $\frac{1}{4}$ " BSP
⑥	011152	4	Dowty seal $\frac{1}{4}$ " BSP
⑦	000241	1	Bolt HT M24 x 130
⑧	000008	1	Nyloc nut T M24
⑨	011329	1	Hose $\frac{1}{4}$ " x 1200, from Port C hopper control valve to hopper lift ram lower
⑩	011329	1	Hose $\frac{1}{4}$ " x 1200, from Port D hopper control valve to hopper lift ram raise

Hopper door ram

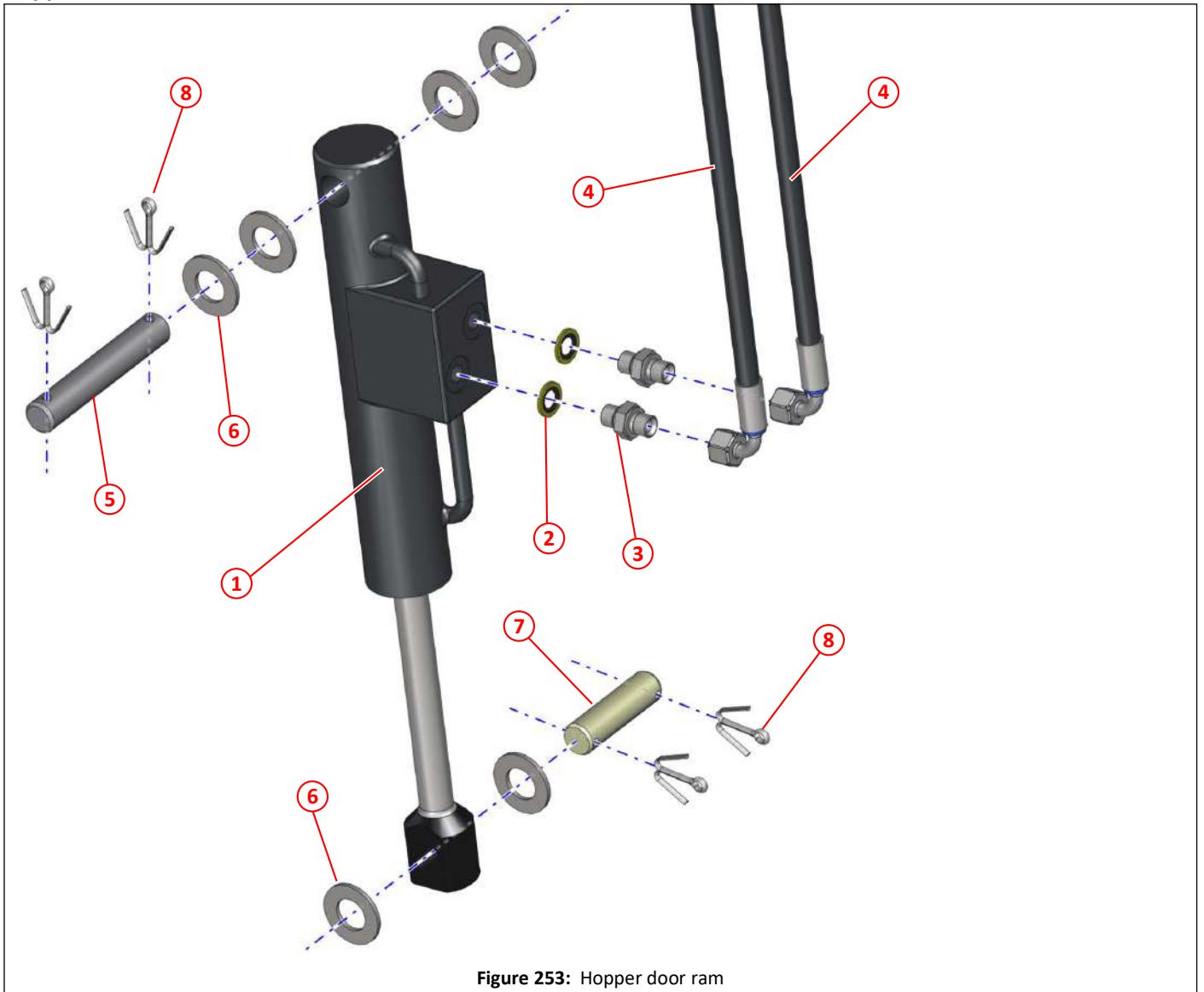
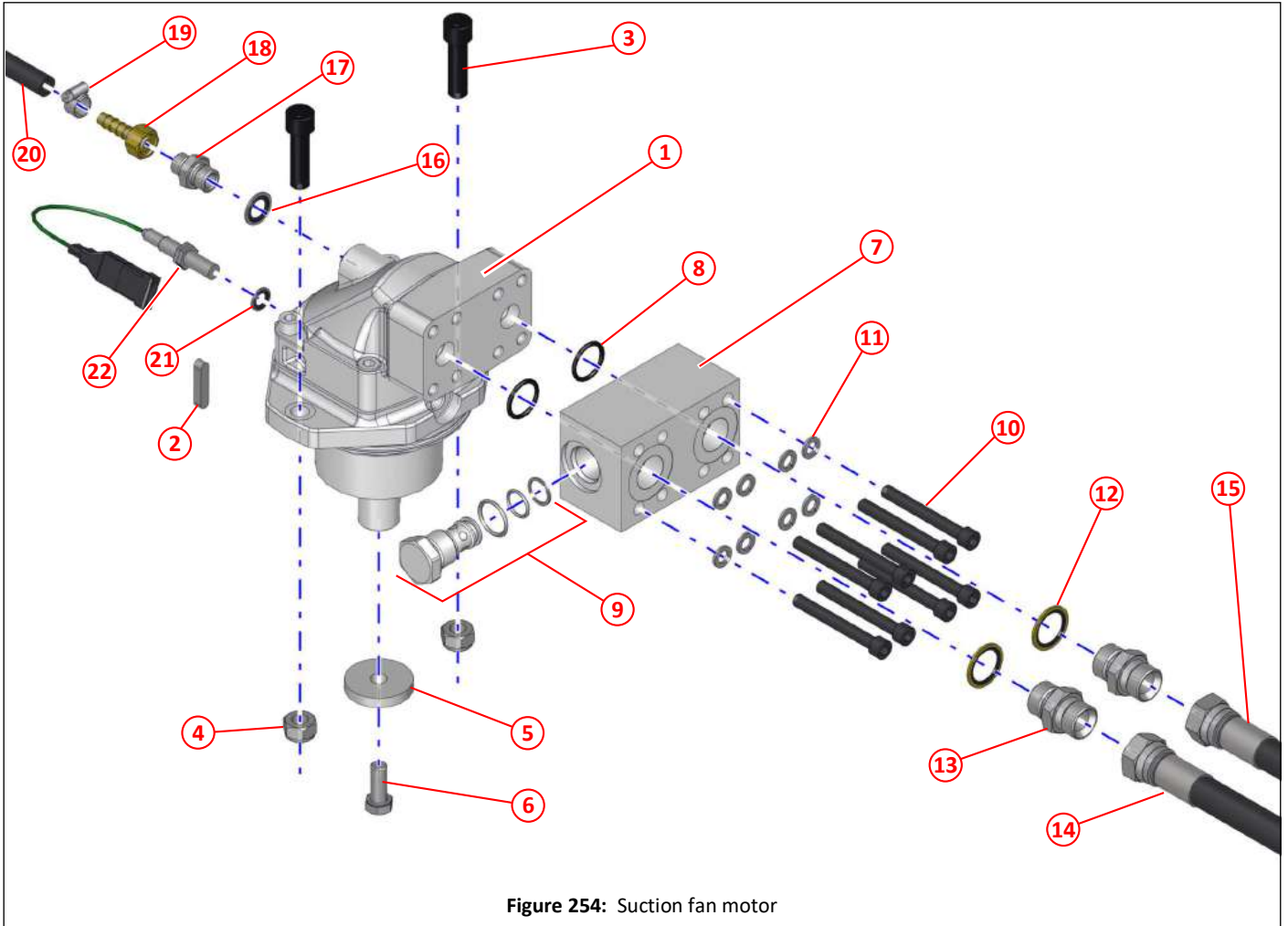

Figure 253: Hopper door ram

Item	Part No	Qty	Description
①	022511	1	Ram, hopper door
②	011152	2	Dowty seal $\frac{1}{4}$ " BSP
③	011158	2	Adapter $\frac{1}{4}$ " BSP
④	001216	2	Hose $\frac{1}{4}$ " x 1450, straight and 90° ends
⑤	022558	1	Ram pin, rear door
⑥	011102	6	Washer M20
⑦	014038	1	Pin 20 x 70
⑧	011122	4	Split pin, $\frac{3}{16}$ " x $1\frac{1}{2}$ "

Suction fan motor



Item	Part No	Qty	Description
①	024641	1	Motor F12-030-MF-CH-K-000-000-P
②	013292	1	Key for item ①
③	000343	2	Socket cap head bolt M14 x 50, black
④	011127	2	Nyloc nut T M14
⑤	044926	1	Washer $\varnothing 50 \times \varnothing 12.5 \times 8$, stainless steel
⑥	011052	1	Setscrew M12 x 30
⑦	041633 *	1	Manifold
⑧	041634 *	2	'O' ring
⑨	041635 *	1	Check valve HCV12-20, includes seals
⑩	000048	8	Socket cap head screw M10 x 80
⑪	011095	8	Spring washer M10
⑫	011155	2	Dowty seal $\frac{3}{4}$ " BSP
⑬	011161	2	Adapter $\frac{3}{4}$ " BSP
⑭	001322	1	Hose $\frac{5}{8}$ " x 1550 with $\frac{3}{4}$ " BSP straight ends
⑮	001323	1	Hose $\frac{5}{8}$ " x 1700 with $\frac{3}{4}$ " BSP straight ends
⑯	011247	1	Dowty seal M18
⑰	011248	1	Adapter M18 x $\frac{3}{8}$ " BSP
⑱	010921	1	$\frac{3}{8}$ " BSP x $\frac{3}{8}$ " hose end, complete with nut
⑲	010516	1	Hose clip, worm drive, No MOO [$\varnothing 11$ - $\varnothing 16$]
⑳	010958	1	Hose, $\frac{3}{8}$ ", fuel, length as required
㉑	011215	1	Dowty seal M12
㉒	025184	1	Speed sensor
*	041564	1	Anti-cavitation valve assembly, includes items ⑦, ⑧ and ⑨

Steel pipes for suction fan - hopper rear left mounted

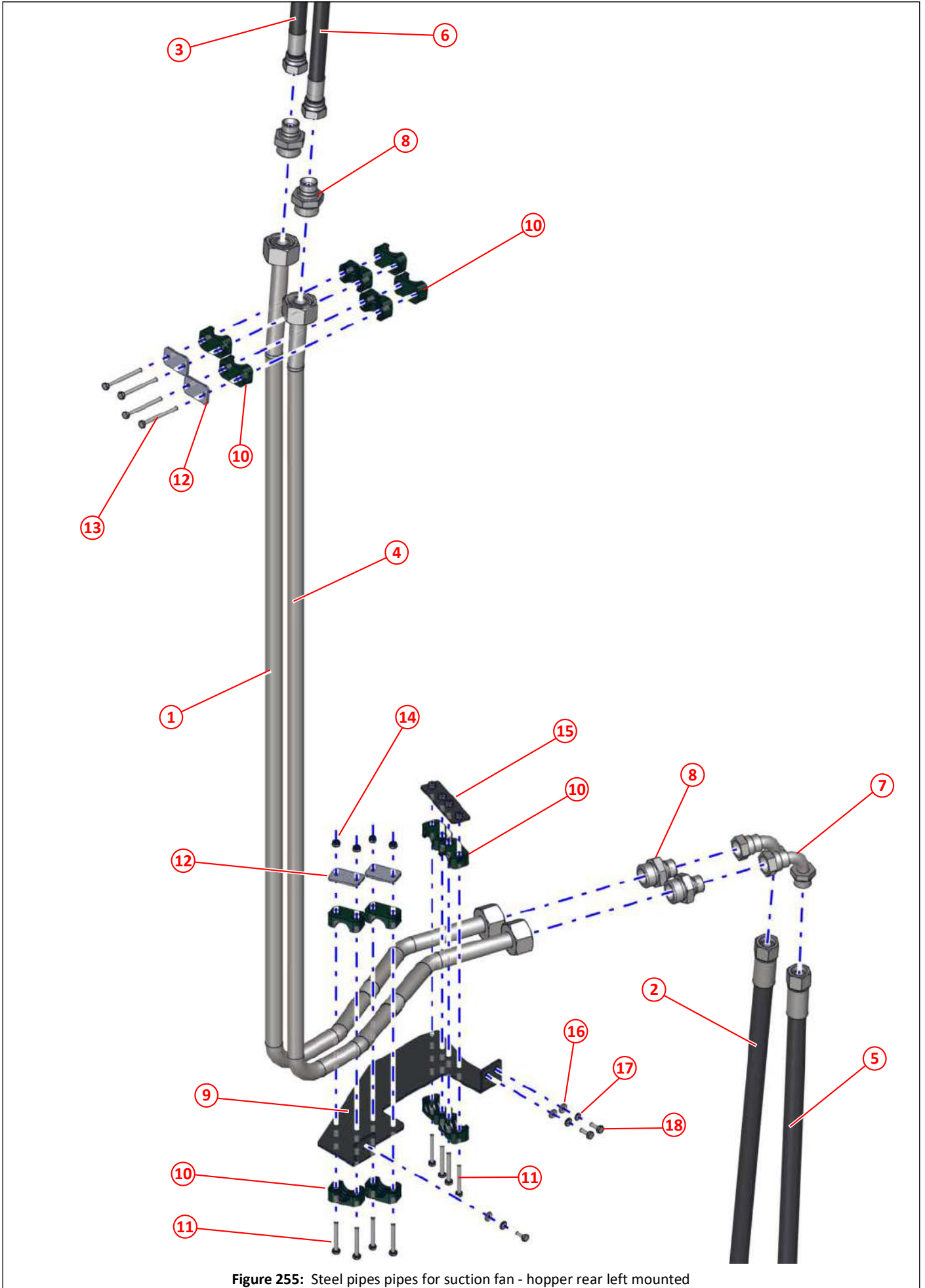

Figure 255: Steel pipes for suction fan - hopper rear left mounted

Item	Part No	Qty	Description
①	047043	1	Steel pipe, suction fan, feed, hopper
②	001374	1	Hose $\frac{3}{4}$ " x 5900, straight and 90° ends, from fan pump
③	001322	1	Hose $\frac{5}{8}$ " x 1550, straight $\frac{3}{4}$ " BSP ends, to suction fan motor
④	047044	1	Steel pipe, suction fan, return, hopper
⑤	001375	1	Hose $\frac{3}{4}$ " x 6225, straight and 90° ends, return to tank
⑥	001223	1	Hose $\frac{5}{8}$ " x 2500, straight $\frac{3}{4}$ " BSP ends, from suction fan motor
⑦	011196	2	Elbow, swept, $\frac{3}{4}$ " BSP, male/female 90°
⑧	002280	4	Male stud 25 x $\frac{3}{4}$ " BSP
⑨	048669	1	Support, steel pipe, suction fan
⑩	027982	14	Pipe clamp block, single \varnothing 25
⑪	011003	8	Setscrew HT M6 x 50
⑫	027990	4	Top plate, Pipe clamp, 2 holes, large
⑬	011143	4	Setscrew HT M6 x 70
⑭	011071	4	Nyloc nut T M6
⑮	047047	1	Clamp plate, fan steel pipe
⑯	011090	3	Washer M6
⑰	011091	3	Spring washer M6
⑱	011001	3	Setscrew M6 x 16

Steel pipes for hopper rear door ram and suction fan drain - hopper rear right mounted

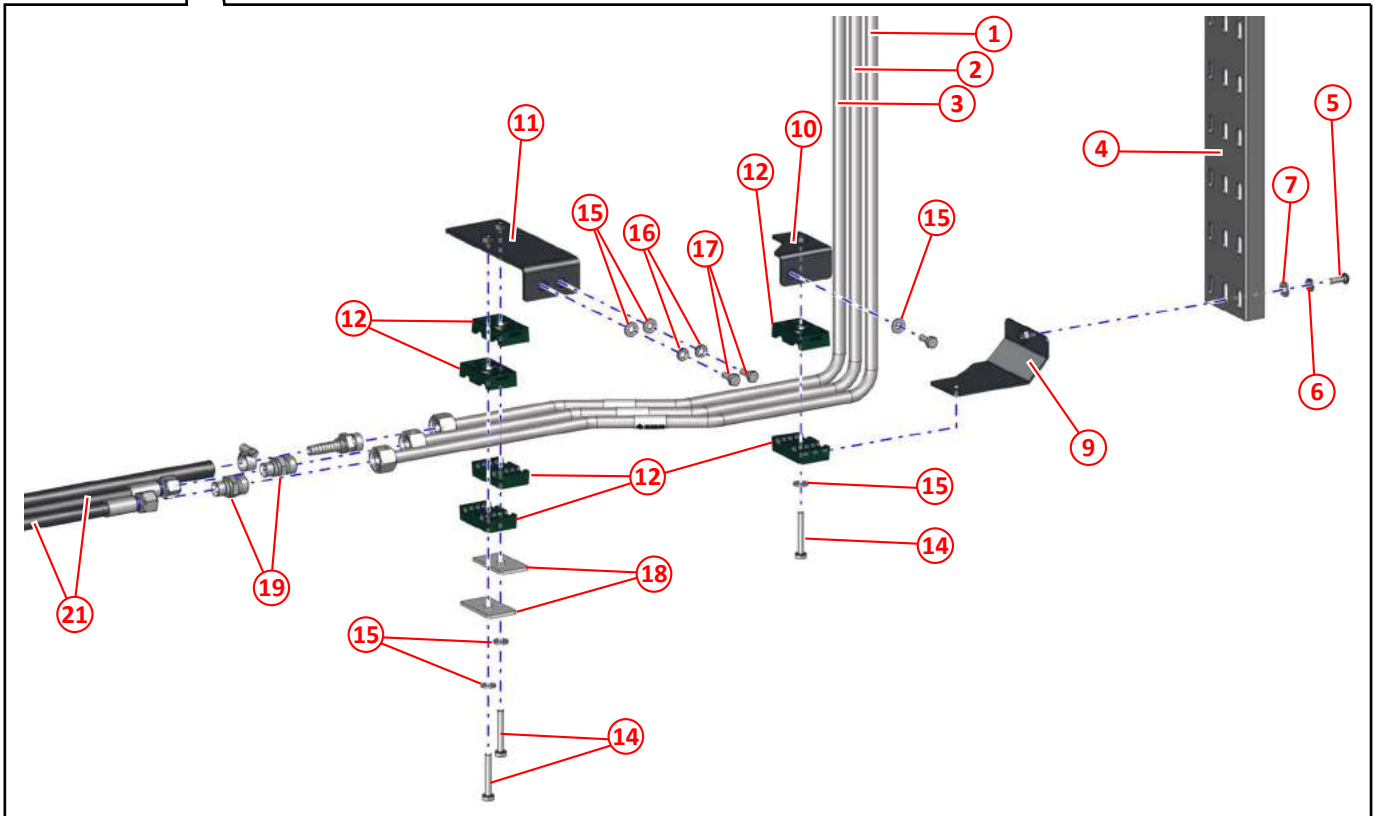
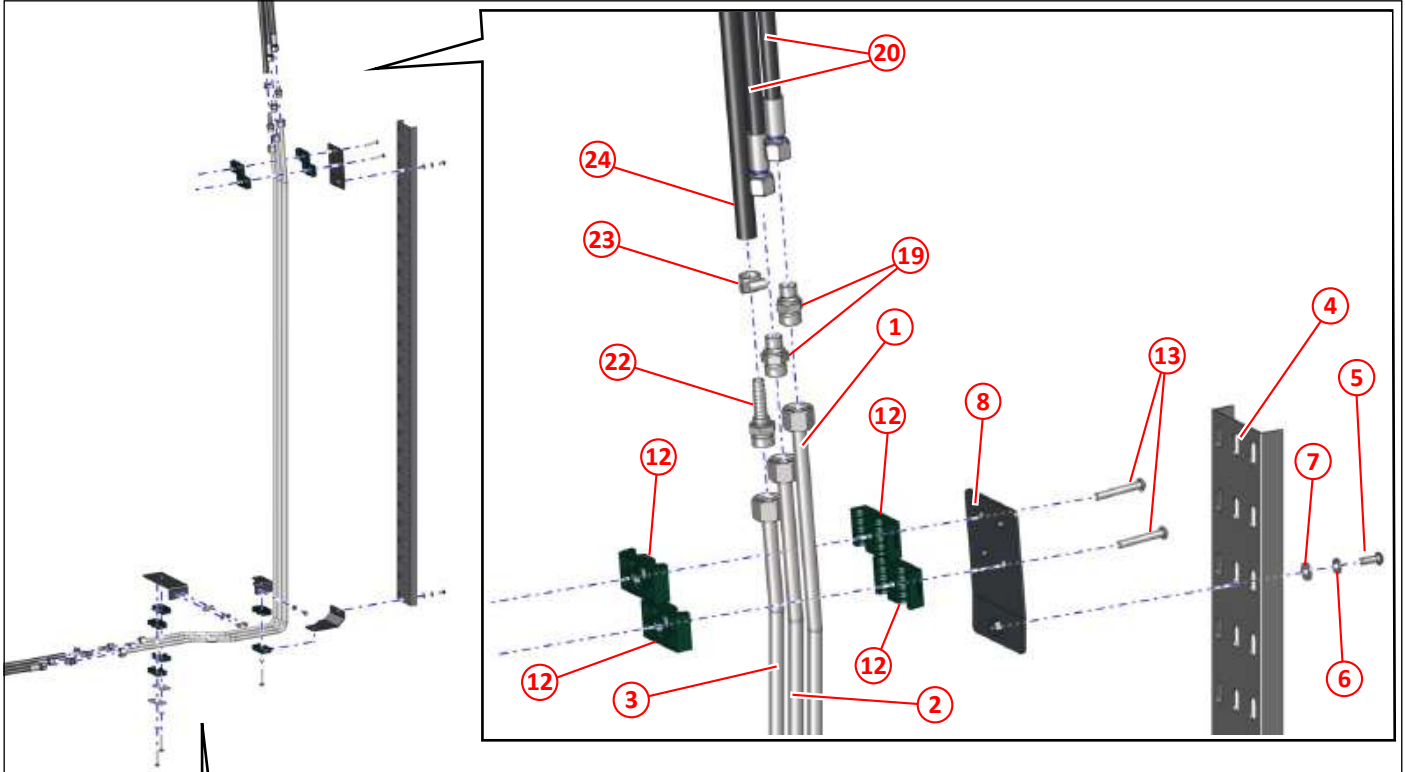

Figure 256: Steel pipes for hopper rear door ram and suction fan drain - hopper rear right mounted

Item	Part No	Qty	Description
①	047045	1	Pipe, steel, door open (hopper)
②	048005	1	Pipe, steel, door close (hopper)
③	048006	1	Pipe, steel, door services
④	048365	1	Plastic cable tray
⑤	000373	2	Socket dome head screw M6 x 16, stainless steel
⑥	000255	2	Spring washer M6, stainless steel
⑦	000254	2	Washer M6, stainless steel
⑧	048363	1	Mounting, upper, plastic cable tray
⑨	048361	1	Mounting, lower, plastic cable tray
⑩	048362	1	Support, plastic cable tray
⑪	047048	1	Bracket, support, door services
⑫	043590	10	Pipe clamp block, $\varnothing 12.7 \times \varnothing 12.7$, double
⑬	000479	2	Socket dome head screw M6 x 40, plated
⑭	000021	3	Setscrew HT M6 x 40
⑮	011090	6	Washer M6
⑯	011091	2	Spring washer M6
⑰	011001	3	Setscrew HT M6 x 16
⑱	046465	2	Clamp plate flat, 52 x 30 x 3
⑲	002086	4	Stud, male 12 x $\frac{1}{4}$ " BSP
⑳	001216	2	Hose $\frac{1}{4}$ " x 1450, straight and 90° ends
㉑	001036	2	Hose $\frac{1}{4}$ " x 4100, straight ends
㉒	002274	2	Adapter, $\varnothing 12\text{MM}$ 24° cone seat x $\frac{3}{8}$ " hose tail
㉓	010516	2	Jubilee clip No. MOO [$\varnothing 11$ - $\varnothing 16\text{mm}$]
㉔	010958	2	Hose $\frac{3}{8}$ ", cut to required length(s), suction fan drain

Hopper door locking arrangement

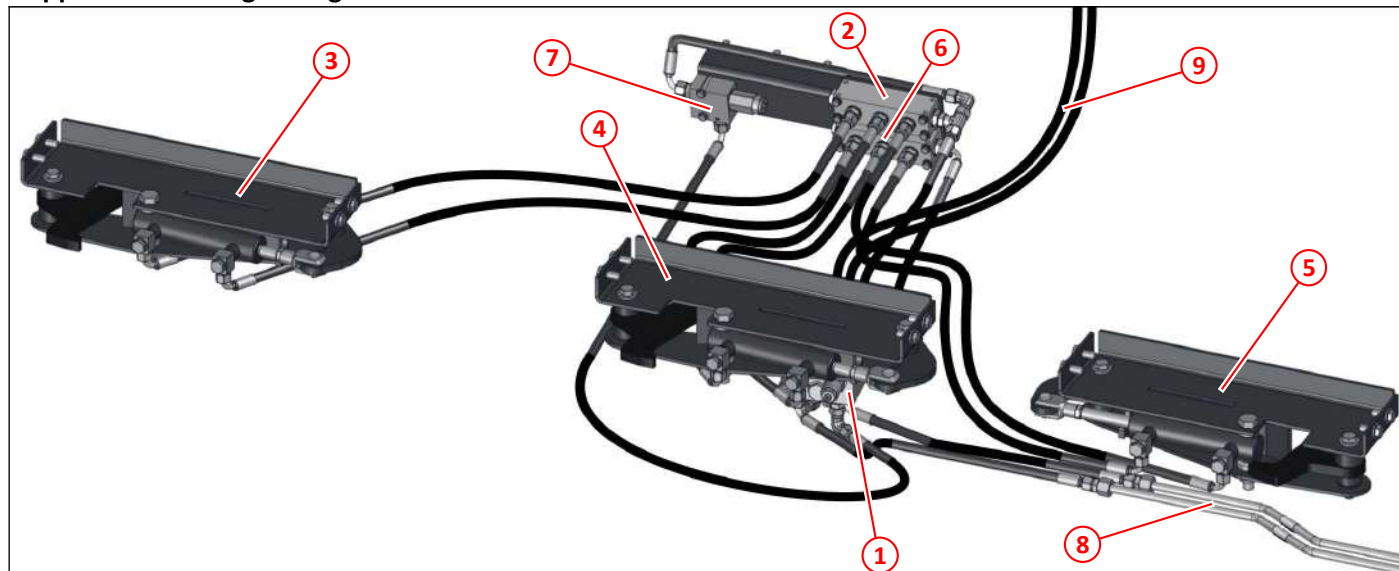

Figure 257: Hopper door locking arrangement

Item	Part No	Qty	Description	
①			Valve sequence and pilot check block, door locking and opening	297
②			Manifold $\frac{1}{4}$ " (3 x out) $\frac{3}{8}$ " (1 x in), ram(s) open	
③			Door locking, left side	
④			Door locking, middle	
⑤			Door locking, right side	
⑥			Manifold $\frac{1}{4}$ " (3 x out) $\frac{3}{8}$ " (1 x in), ram(s) close	
⑦			Pressure relief valve	
⑧			Steel pipes, door open/close	
⑨			Feed and return hoses from hopper/door controller	

Sequence and pilot check valve block, hopper door locking

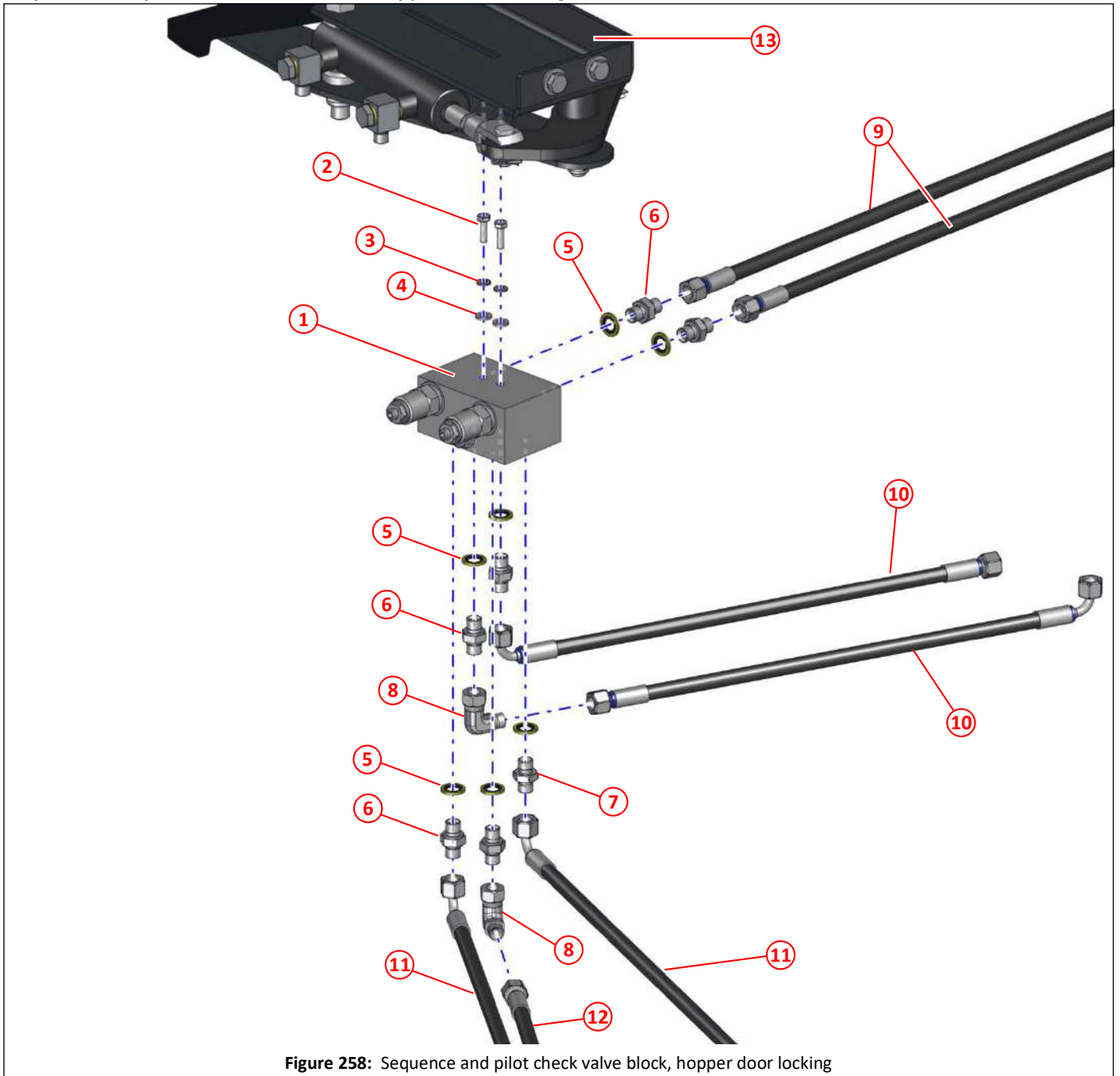

Figure 258: Sequence and pilot check valve block, hopper door locking

Item	Part No	Qty	Description
①	023483	1	Valve sequence and pilot check block, door locking and opening
②	011067	2	Setscrew HT M6 x 20
③	011091	2	Spring Washer M6
④	011090	2	Washer M6
⑤	011152	7	Dowty seal 1/4" BSP
⑥	011158	6	Adapter 1/4" BSP
⑦	012539	1	Restrictor No 5, 1/4" BSP x 1/4" BSP x 1/32", white
⑧	011171	2	Elbow, swivel, male/female, 1/4" BSP
⑨	001036	2	Hose, 1/4" x 4100, straight ends, from/to hopper controller
⑩	001100	2	Hose, 1/4" x 460, straight and 90° ends, from/to manifolds (in)
⑪	001251	2	Hose, 1/4" x 600, straight and 90° ends, from/to door open ram
⑫	001104	1	Hose, 1/4" x 1020, straight and 90° ends, to pressure relief valve
⑬			Door locking, middle

Hopper door locking assembly, middle and left side

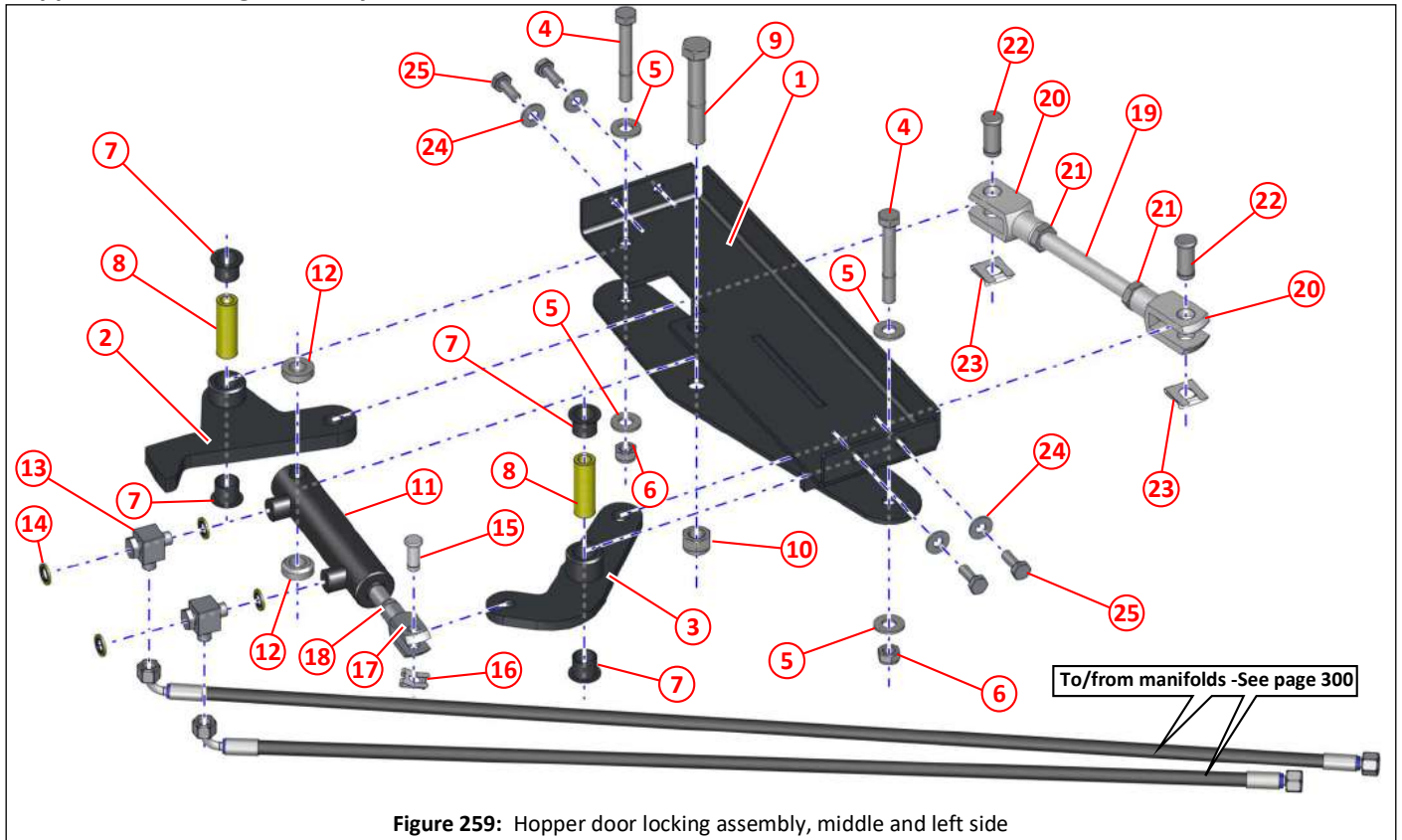

Figure 259: Hopper door locking assembly, middle and left side

Item	Part No	Qty	Description
①	048020	1	Mount, rear door locking, middle and left side
②	048021	1	Latch, rear door locking
③	046892	1	Operating lever, rear door locking
④	000139	2	Bolt M12 x 90 (10.9)
⑤	011096	4	Washer M12
⑥	011077	2	Nyloc nut T M12
⑦	013488	4	Bush
⑧	022451	2	Spacer $\varnothing 20 \times \varnothing 12.5 \times 60$
⑨	011133	1	Bolt HT M16 x 100
⑩	011060	1	Nyloc nut T M16
⑪	022350	1	Ram, Rear door locking
⑫	022639	2	Spacer $\varnothing 30 \times \varnothing 16 \times 10$
⑬	002017	2	Banjo adapter, $\frac{1}{4}$ " BSP
⑭	011152	4	Dowty seal $\frac{1}{4}$ " BSP
⑮	023270	1	Clevis pin $\varnothing 12$
⑯	023269	1	Clip, retaining, $\varnothing 12$
⑰	014469	1	Clevis M12
⑱	000211	1	Locknut, M12 x 1.25
⑲	047029	1	Connecting link, rear door locking
⑳	020299	2	Clevis M16 x 1.5
㉑	000138	2	Locknut M16 x 1.5
㉒	022673	2	Clevis pin (turned)
㉓	022674	2	Clip, retaining, M16
㉔	000270	4	Washer M10, stainless steel
㉕	000280	4	Setscrew M10 x 25, stainless steel

Hopper door locking assembly, right side

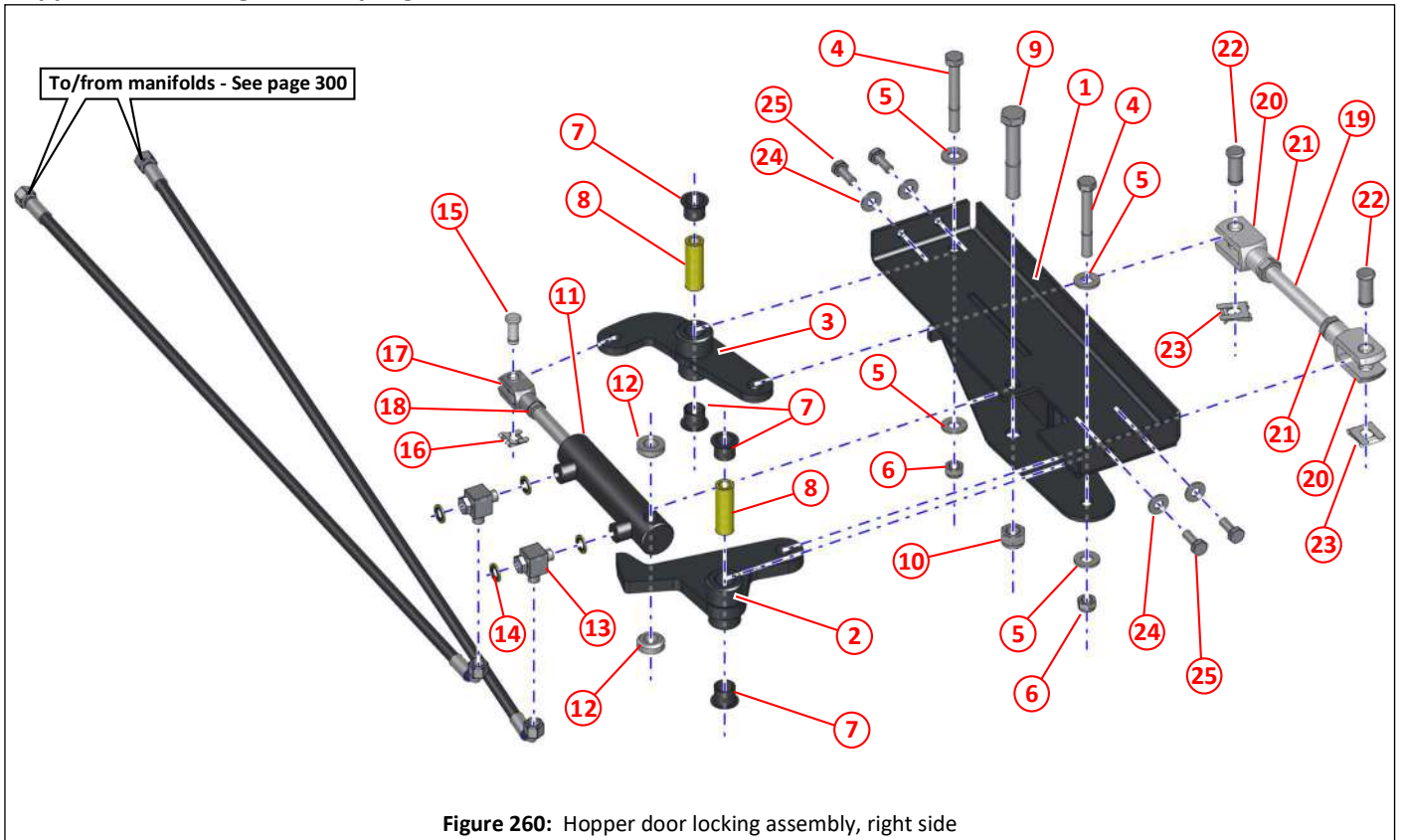

Figure 260: Hopper door locking assembly, right side

Item	Part No	Qty	Description
①	048019	1	Mount, rear door locking, right site
②	048021	1	Latch, rear door locking
③	046892	1	Operating lever, rear door locking
④	000139	2	Bolt M12 x 90 (10.9)
⑤	011096	4	Washer M12
⑥	011077	2	Nyloc nut T M12
⑦	013488	4	Bush
⑧	022451	2	Spacer $\varnothing 20 \times \varnothing 12.5 \times 60$
⑨	011133	1	Bolt HT M16 x 100
⑩	011060	1	Nyloc nut T M16
⑪	022350	1	Ram, Rear door locking
⑫	022639	2	Spacer $\varnothing 30 \times \varnothing 16 \times 10$
⑬	002017	2	Banjo adapter, $\frac{1}{4}$ " BSP
⑭	011152	4	Dowty seal $\frac{1}{4}$ " BSP
⑮	023270	1	Clevis pin $\varnothing 12$
⑯	023269	1	Clip, retaining, $\varnothing 12$
⑰	014469	1	Clevis M12
⑱	000211	1	Locknut, M12 x 1.25
⑲	047029	1	Connecting link, rear door locking
⑳	020299	2	Clevis M16 x 1.5
㉑	000138	2	Locknut M16 x 1.5
㉒	022673	2	Clevis pin (turned)
㉓	022674	2	Clip, retaining, M16
㉔	000270	4	Washer M10, stainless steel
㉕	000280	4	Setscrew M10 x 25, stainless steel

Door locking manifolds and pressure relief valve

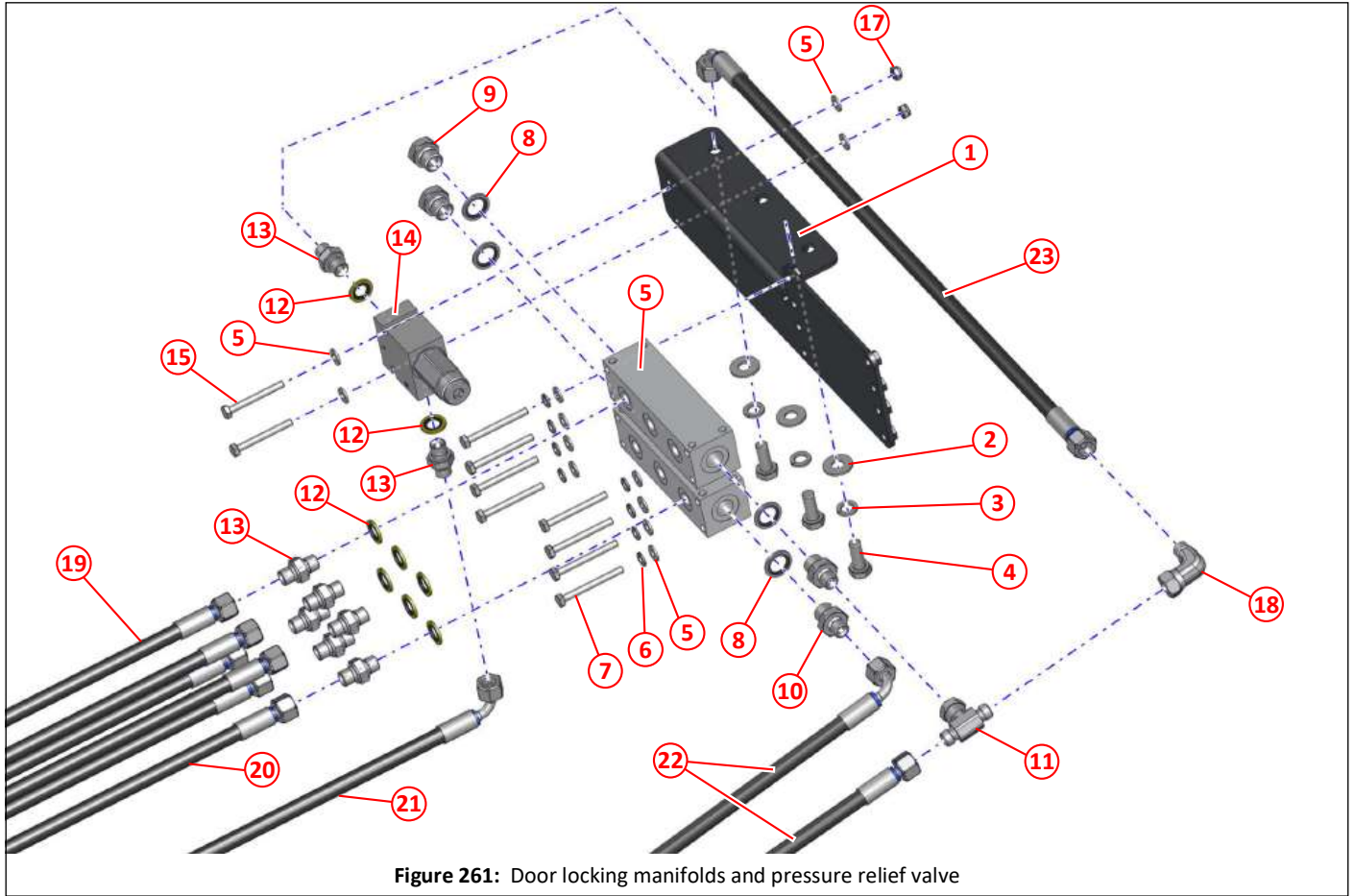

Figure 261: Door locking manifolds and pressure relief valve

Item	Part No	Qty	Description
①	048477	1	Bracket, manifolds, rear door locking
②	011094	3	Washer M10
③	011095	3	Spring washer M10
④	011031	3	Setscrew HT M10 x 25
⑤	011090	12	Washer M6
⑥	011091	8	Spring washer M6
⑦	000018	8	Setscrew HT M6 x 55
⑧	011153	4	Dowty seal $\frac{3}{8}$ " BSP
⑨	011242	2	Plug $\frac{3}{8}$ " BSP
⑩	011199	2	Adapter $\frac{3}{8}$ " x $\frac{1}{4}$ " BSP
⑪	002009	1	Tee, $\frac{1}{4}$ " BSP, nut on branch
⑫	011152	8	Dowty seal $\frac{1}{4}$ " BSP
⑬	011158	8	Adapter $\frac{1}{4}$ " BSP
⑭	043941	1	Pressure relief valve
⑮	011003	2	Setscrew HT M6 x 50
⑯	047243	2	Manifold $\frac{1}{4}$ " (3 x out) $\frac{3}{8}$ " (1 x in), ram(s) open/close
⑰	011071	2	Nyloc nut T M6
⑱	011171	1	Elbow, $\frac{1}{4}$ " BSP, swivel, male/female
⑲	001101	3	Hose $\frac{1}{4}$ " x 1125, straight and 90° ends, door locking ram extend
⑳	001202	3	Hose $\frac{1}{4}$ " x 1000, straight and 90° ends, door locking ram retract
㉑	001104	1	Hose $\frac{1}{4}$ " x 1020, straight and 90° ends, from sequence valve block port DR
㉒	001100	2	Hose $\frac{1}{4}$ " x 460, straight and 90° ends, from sequence valve block ports A and D
㉓	001251	1	Hose $\frac{1}{4}$ " x 600, straight and 90° ends, from pressure relief valve port 1

Steel pipes, fittings and hoses for dual sweep brushes

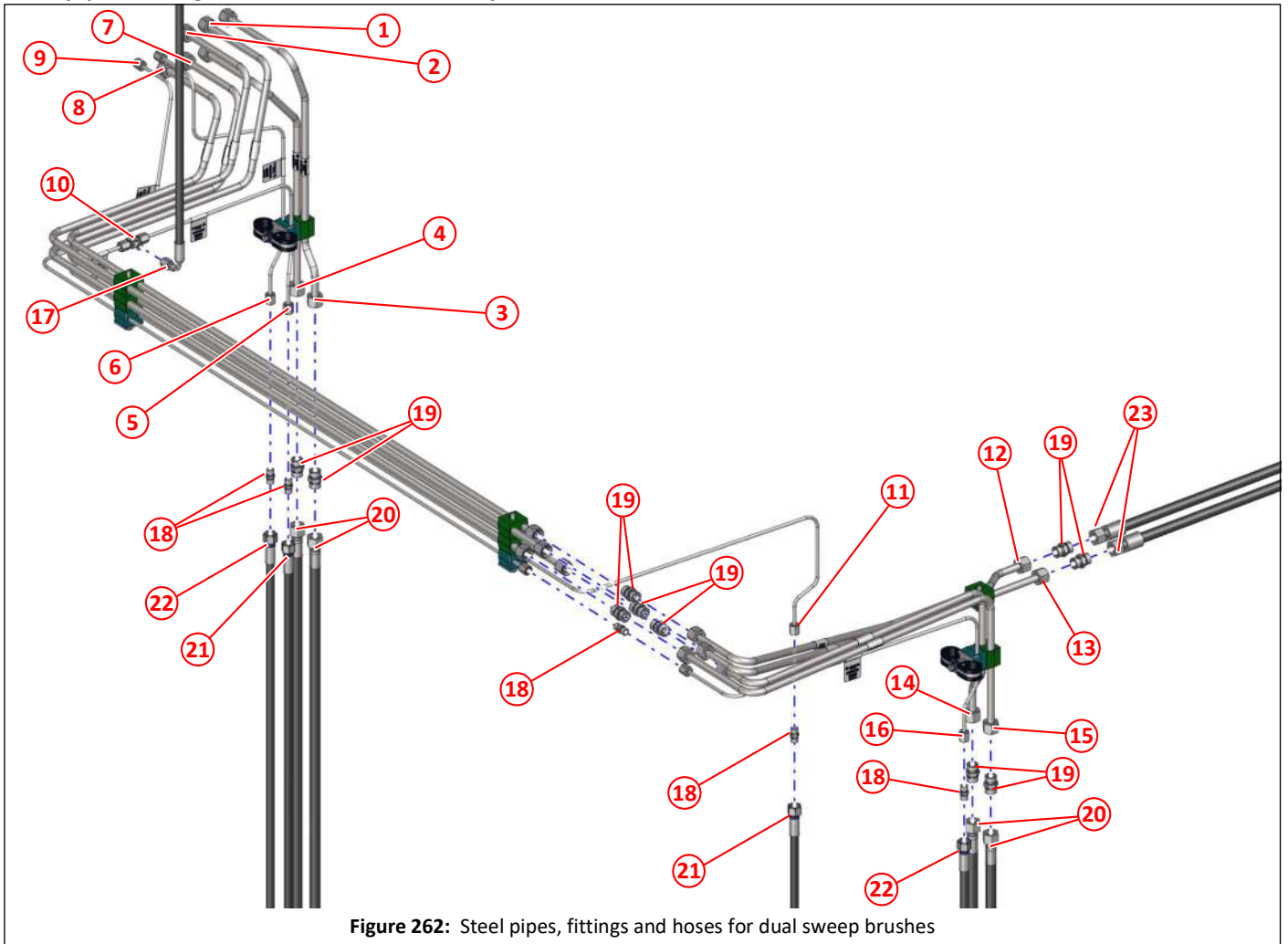

Figure 262: Steel pipes, fittings and hoses for dual sweep brushes

Item	Part No	Qty	Description	
①	043405	1	Steel pipe, left hand brush motor feed PT 1	
②	043416	1	Steel pipe, central brush motor feed PT 1	
③	043412	1	Steel pipe, right hand brush motor feed	
④	043413	1	Steel pipe, right hand brush motor return	
⑤	043415	1	Steel pipe, right hand suction nozzle tilt ram	
⑥	043414	1	Steel pipe, right hand brush lift ram	
⑦	043407	1	Steel pipe, left hand brush motor return PT 1	
⑧	043418	1	Steel pipe, central brush motor return PT 1	
⑨	043409	1	Steel pipe, left hand brush lift ram PT 1	
⑩	002085	1	Union tee 6mm, body only	
⑪	043411	1	Steel pipe, left hand suction nozzle tilt ram	
⑫	043417	1	Steel pipe, central brush motor feed PT 2	
⑬	043419	1	Steel pipe, central brush motor return PT 2	
⑭	043406	1	Steel pipe, left hand brush motor feed PT 2	
⑮	043408	1	Steel pipe, left hand brush motor return PT 2	
⑯	043410	1	Steel pipe, left hand brush lift ram	
⑰	001367	1	Hose 1/4" x 2220, straight end and 90° stand pipe 6mm end, from control valve block	274
⑱	002052	5	Union tube/tube 6mm x 6mm, body only	
⑲	002088	10	Union tube/tube 12mm x 12mm, body only	
⑳	001372	4	Hose 3/8" BSP x 1400, straight and 45°, to and from side brush motor	
㉑	001101	2	Hose 1/4" BSP x 1125, straight and 90°, to suction nozzle tilt	
㉒	001371	2	Hose 1/4" BSP x 1225, straight and 90°, to side brush lift	
㉓	001167	2	Hose 3/8" BSP x 1200, straight, to and from central brush motor	

Clamps for steel pipes for dual sweep brushes

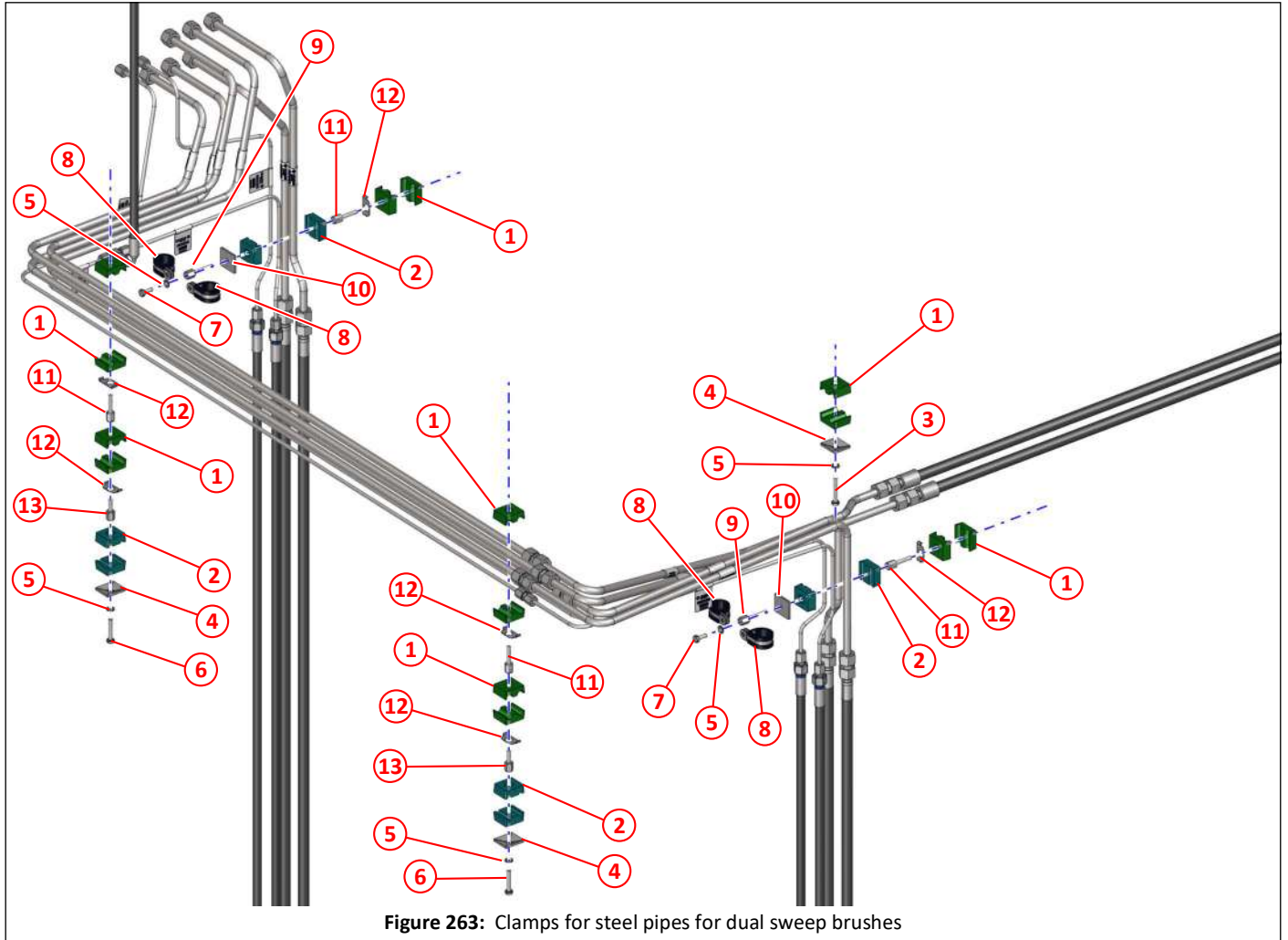

Figure 263: Clamps for steel pipes for dual sweep brushes

Item	Part No	Qty	Description
①	027984	14	Pipe clamp block 12 x 12 double
②	027983	8	Pipe clamp block 6 x 6 double
③	000021	1	Setscrew HT M6 x 40
④	027996	3	Pipe clamp top plate, 1 hole, small
⑤	011091	5	Spring washer M6
⑥	011068	2	Bolt HT M6 x 35
⑦	011001	2	Setscrew HT M6 x 16
⑧	003001	4	Clip ø22, rubber insert
⑨	000470	2	Stacking bolt 35, (AF4)
⑩	028771	2	Hose clamp plate, steel pipe-sub frames
⑪	000469	4	Stacking bolt 30, (AF3)
⑫	000472	6	Locking plate, SIG1
⑬	000467	2	Stacking bolt 20, (AF1)

Steel pipes, fittings and hoses for right hand sweep brushes

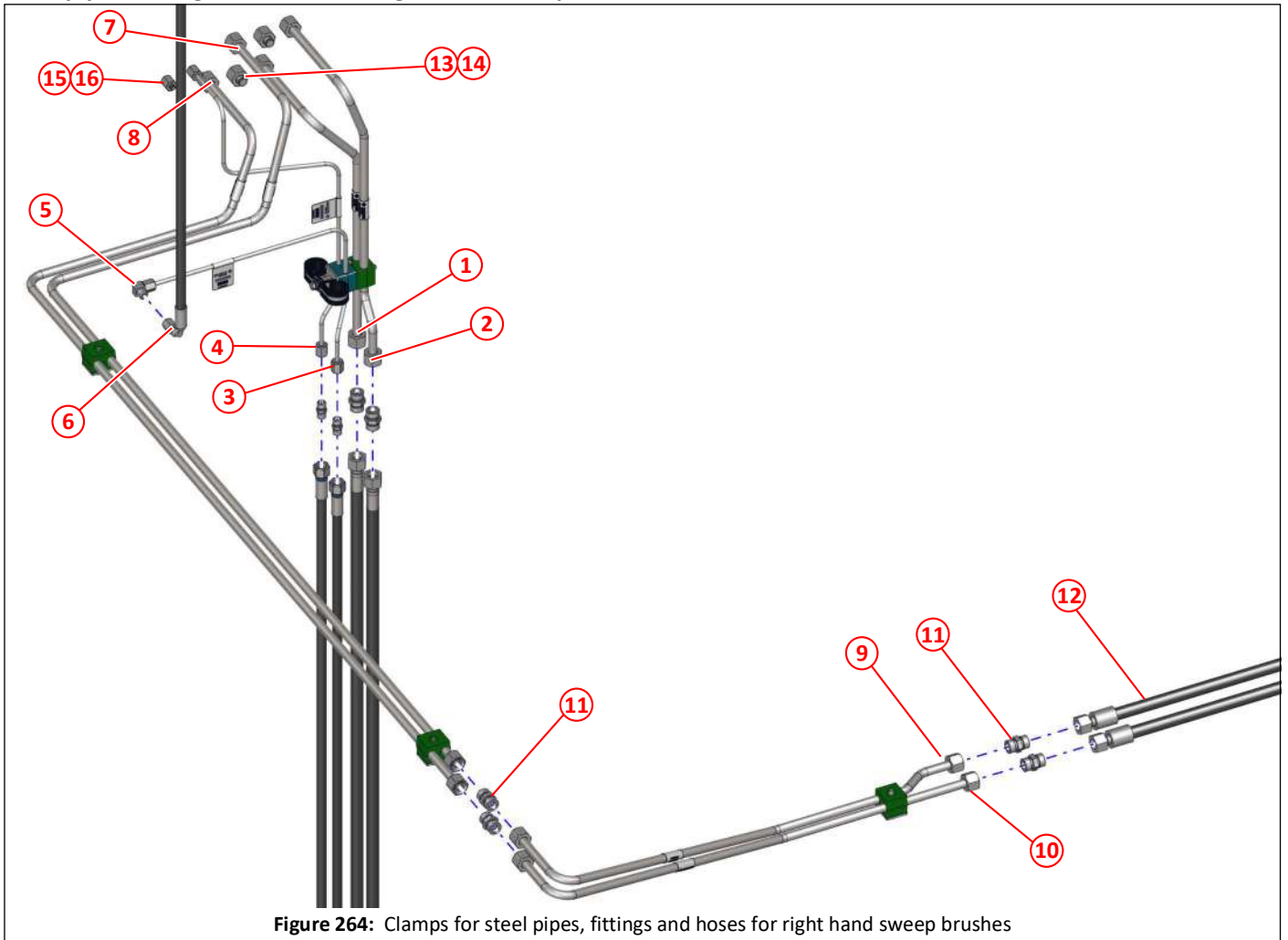

Figure 264: Clamps for steel pipes, fittings and hoses for right hand sweep brushes

Item	Part No	Qty	Description	
①	043413	1	Steel pipe, right hand brush motor return	
②	043412	1	Steel pipe, right hand brush motor feed	
③	043415	1	Steel pipe, right hand suction nozzle tilt ram	
④	043414	1	Steel pipe, right hand brush lift ram	
⑤	002053	1	Union elbow 6mm x 6mm, body only	
⑥	001367	1	Hose $\frac{1}{4}$ " x 2220, straight end and 90° stand pipe 6mm end, from control valve block	274
⑦	043416	1	Steel pipe, central brush motor feed PT 1	
⑧	043418	1	Steel pipe, central brush motor return PT 1	
⑨	043417	1	Steel pipe, central brush motor feed PT 2	
⑩	043419	1	Steel pipe, central brush motor return PT 2	
⑪	002088	4	Union tube/tube 12mm x 12mm, body only	
⑫	001167	2	Hose $\frac{3}{8}$ " BSP x 1200, straight, to and from central brush motor	
⑬	002236	2	Blanking plug 12mm	
⑭	002130	2	Compression nut 12mm	
⑮	002235	1	Blanking plug 6mm	
⑯	002132	1	Compression nut 6mm	

Clamps for steel pipes for right hand sweep brushes

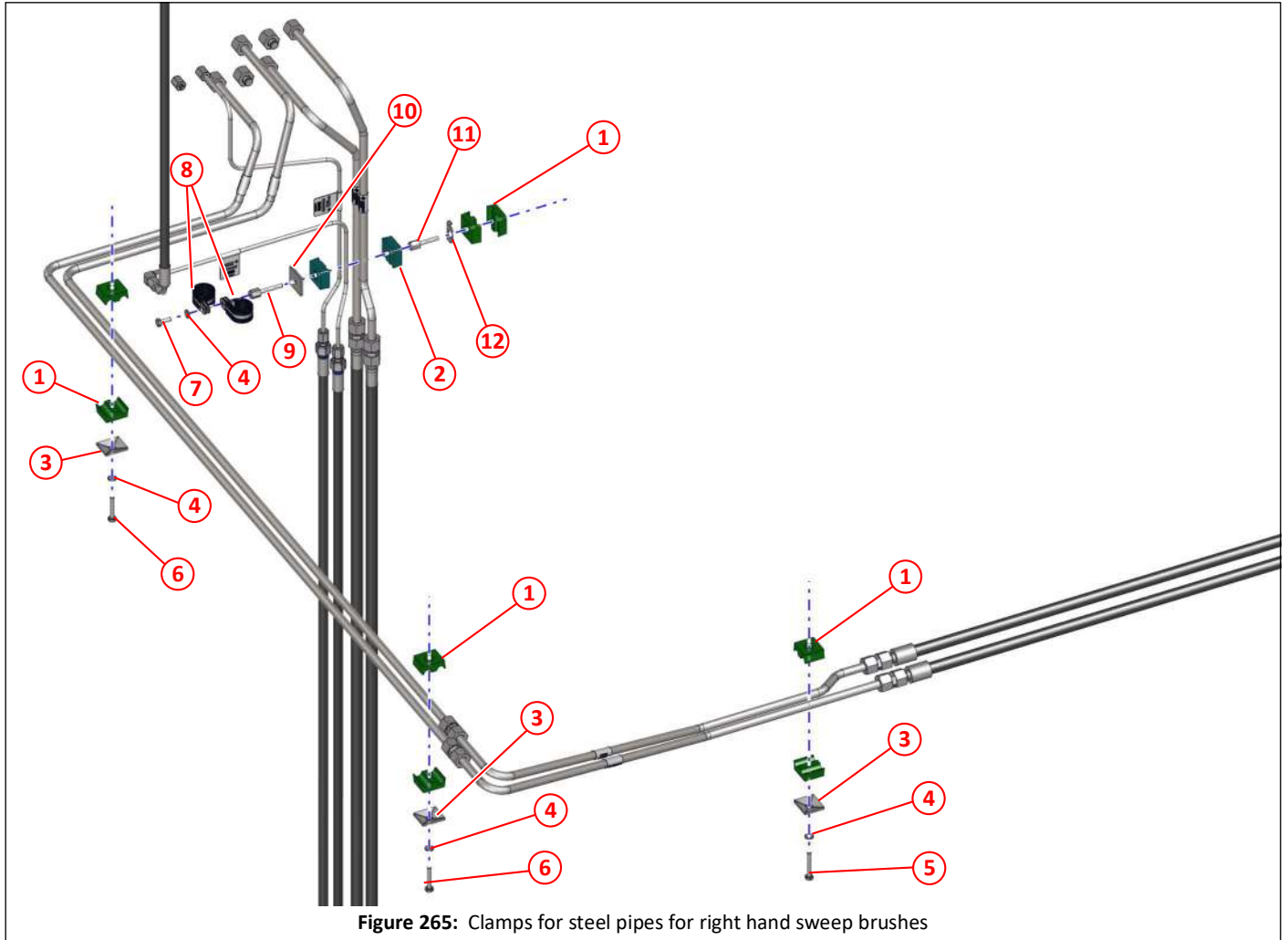

Figure 265: Clamps for steel pipes for right hand sweep brushes

Item	Part No	Qty	Description
①	027984	8	Pipe clamp block 12 x 12 double
②	027983	2	Pipe clamp block 6 x 6 double
③	027996	3	Pipe clamp top plate, 1 hole, small
④	011091	4	Spring washer M6
⑤	000021	1	Setscrew HT M6 x 40
⑥	011068	2	Bolt HT M6 x 35
⑦	011001	1	Setscrew HT M6 x 16
⑧	003001	2	Clip ø22, rubber insert
⑨	000470	1	Stacking bolt 35, (AF4)
⑩	028771	1	Hose clamp plate, steel pipe-sub frames
⑪	000469	1	Stacking bolt 30, (AF3)
⑫	000472	1	Locking plate, SIG1

Steel pipes, fittings and hoses for left hand sweep brushes

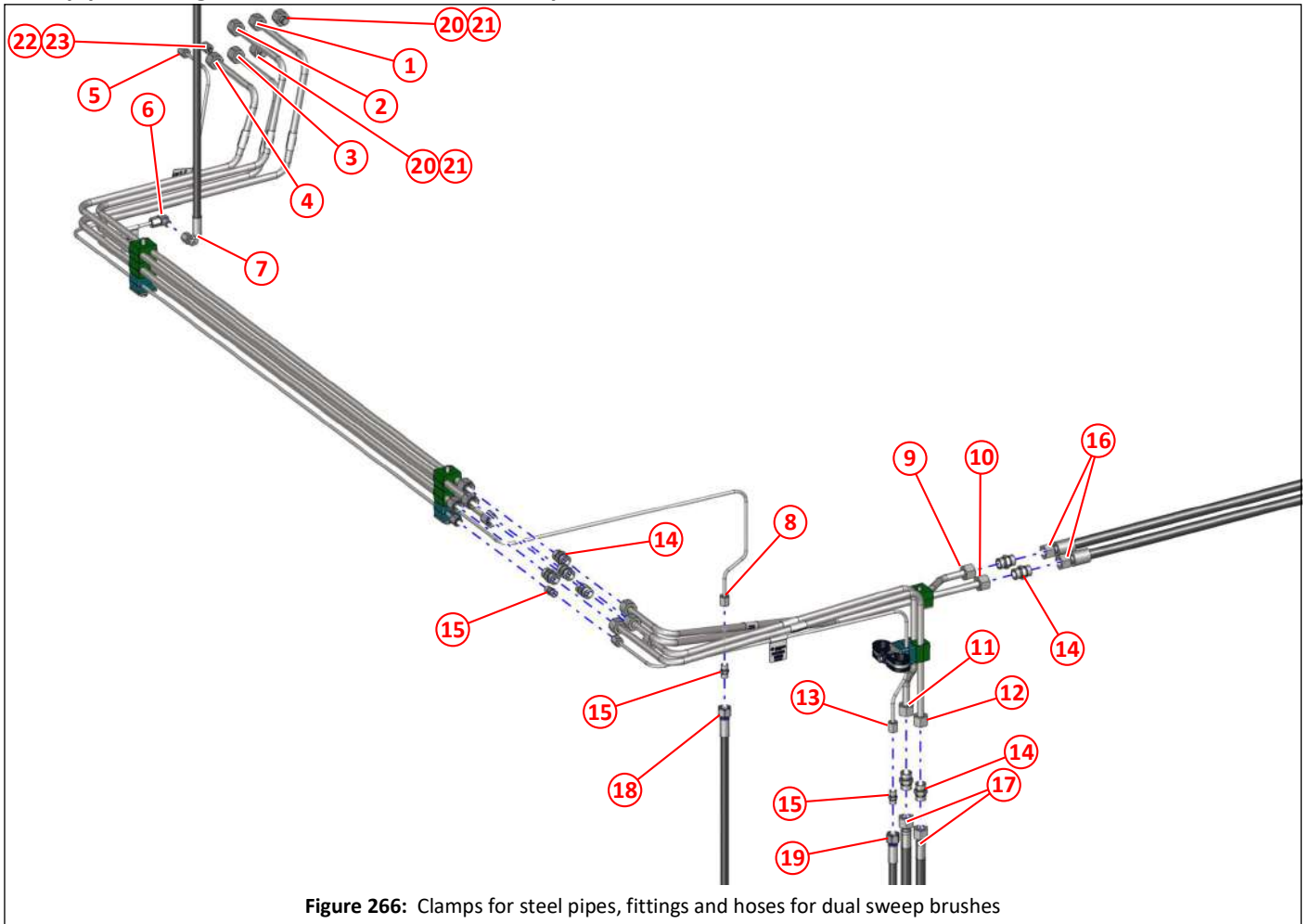

Figure 266: Clamps for steel pipes, fittings and hoses for dual sweep brushes

Item	Part No	Qty	Description	
①	043405	1	Steel pipe, left hand brush motor feed, part 1	
②	043416	1	Steel pipe, central brush motor feed, part 1	
③	043407	1	Steel pipe, left hand brush motor return, part 1	
④	043418	1	Steel pipe, central brush motor return, part 1	
⑤	043409	1	Steel pipe, left hand brush lift ram, part 1	
⑥	002053	1	Union elbow 6mm x 6mm, body only	
⑦	001367	1	Hose $\frac{1}{4}$ " x 2220, straight end and 90° stand pipe 6mm end, from control valve block	274
⑧	043411	1	Steel pipe, left hand suction nozzle tilt ram	
⑨	043417	1	Steel pipe, central brush motor feed, part 2	
⑩	043419	1	Steel pipe, central brush motor return, part 2	
⑪	043406	1	Steel pipe, left hand brush motor feed, part 2	
⑫	043408	1	Steel pipe, left hand brush motor return, part 2	
⑬	043410	1	Steel pipe, left hand brush lift ram	
⑭	002088	8	Union tube/tube 12mm x 12mm, body only	
⑮	002052	3	Union tube/tube 6mm x 6mm, body only	
⑯	001167	2	Hose $\frac{3}{8}$ " BSP x 1200, straight, to and from central brush motor	
⑰	001372	4	Hose $\frac{3}{8}$ " BSP x 1400, straight and 45°, to and from side brush motor	
⑱	001372	4	Hose $\frac{3}{8}$ " BSP x 1400, straight and 45°, to and from side brush motor	
⑲	001371	2	Hose $\frac{1}{4}$ " BSP x 1225, straight and 90°, to side brush lift	
⑳	002236	2	Blanking plug 12mm	
㉑	002130	2	Compression nut 12mm	
㉒	002235	1	Blanking plug 6mm	
㉓	002132	1	Compression nut 6mm	

Clamps for steel pipes left hand sweep brushes

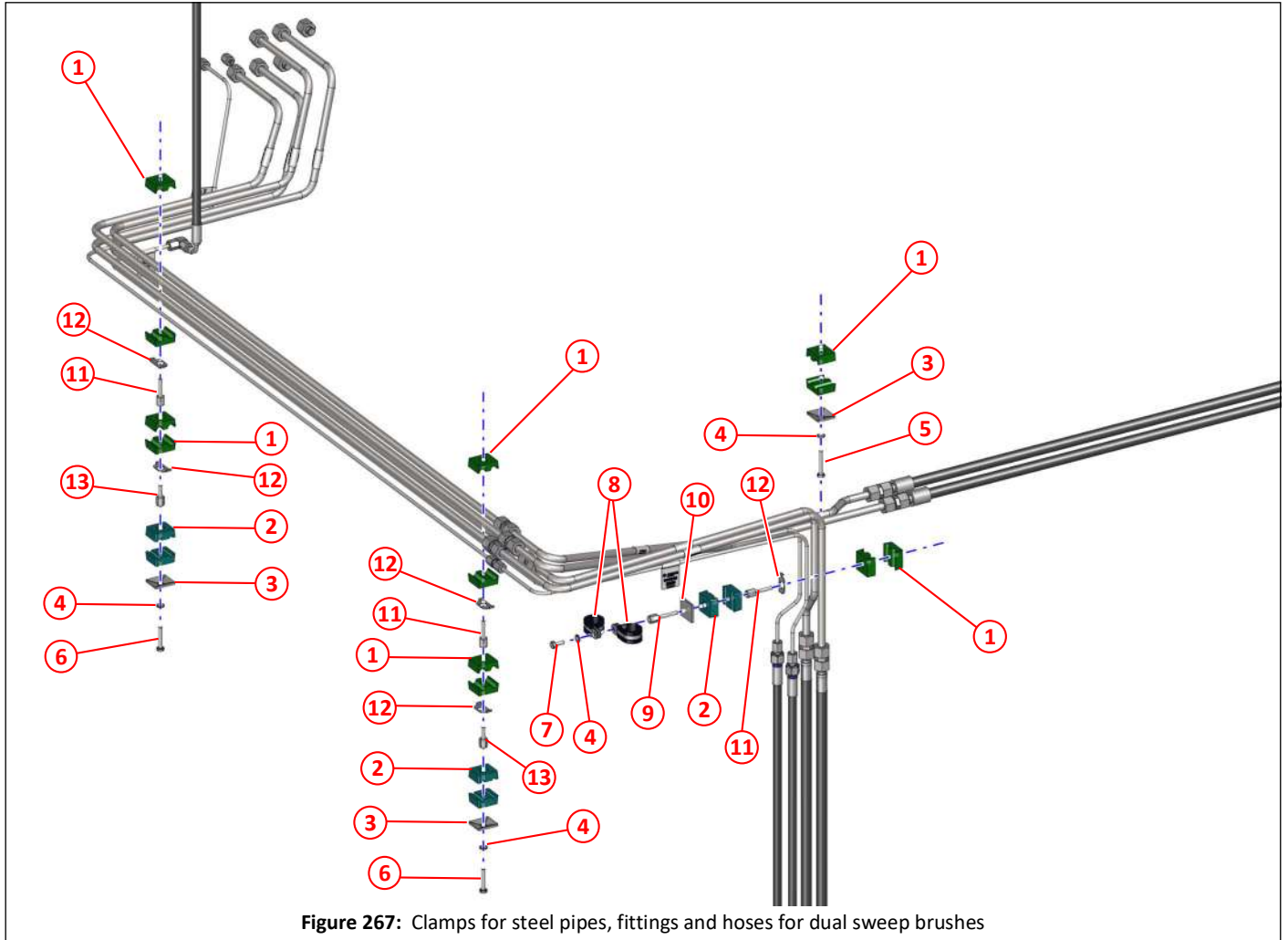

Figure 267: Clamps for steel pipes, fittings and hoses for dual sweep brushes

Item	Part No	Qty	Description
①	027984	12	Pipe clamp block 12 x 12 double
②	027983	6	Pipe clamp block 6 x 6 double
③	027996	3	Pipe clamp top plate, 1 hole, small
④	011091	4	Spring washer M6
⑤	000021	1	Setscrew HT M6 x 40
⑥	011068	2	Bolt HT M6 x 35
⑦	011001	1	Setscrew HT M6 x 16
⑧	003001	2	Clip ø22, rubber insert
⑨	000470	1	Stacking bolt 35, (AF4)
⑩	028771	1	Hose clamp plate, steel pipe-sub frames
⑪	000469	3	Stacking bolt 30, (AF3)
⑫	000472	5	Locking plate, SIG1
⑬	000467	2	Stacking bolt 20, (AF1)

Side brush motor

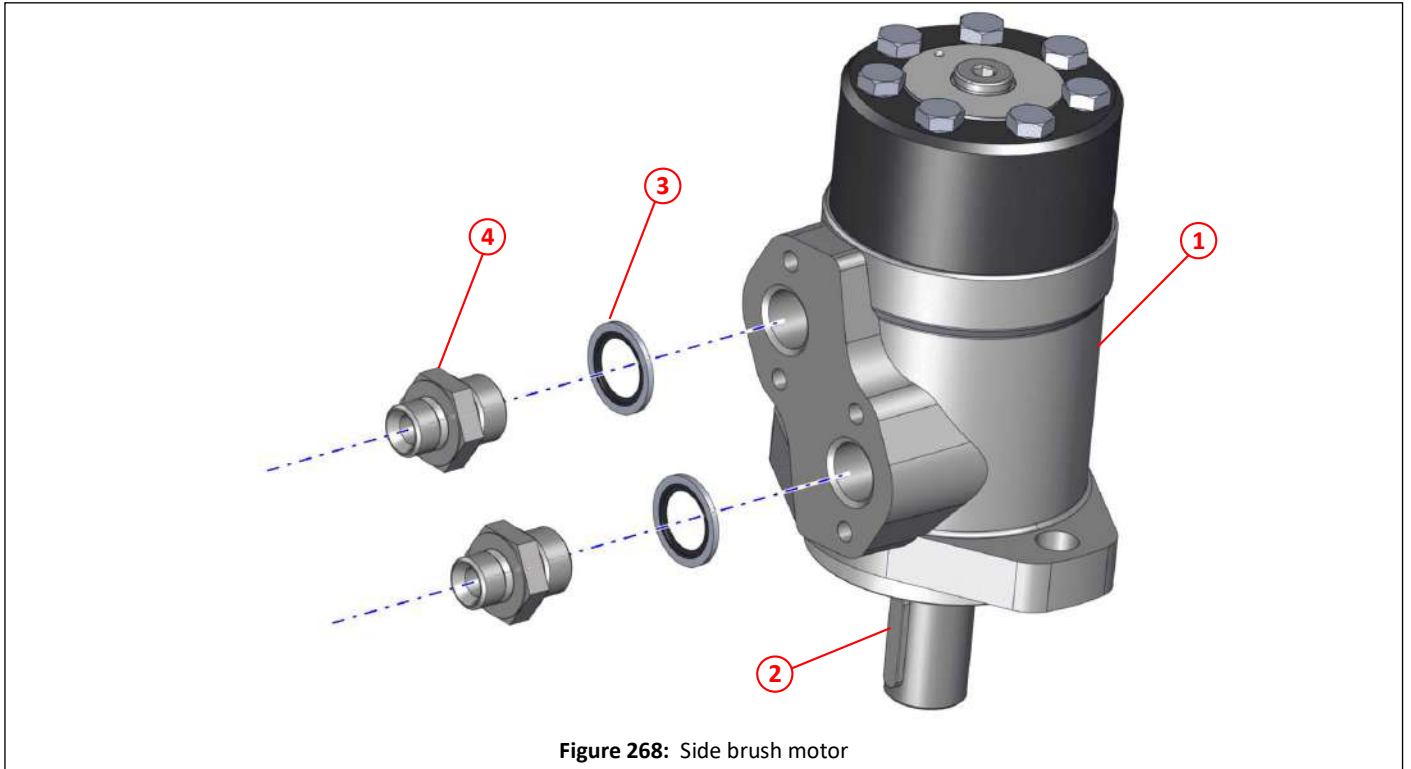

Figure 268: Side brush motor

Item	Part No	Qty	Description
①	010749	1	Motor 3597 (OMP 200)
②	011515	1	Key for motor
③	011154	2	Dowty seal $\frac{1}{2}$ " BSP
④	011167	2	Adapter $\frac{1}{2}$ " x $\frac{3}{8}$ " BSP

Central brush (wide sweep) motor

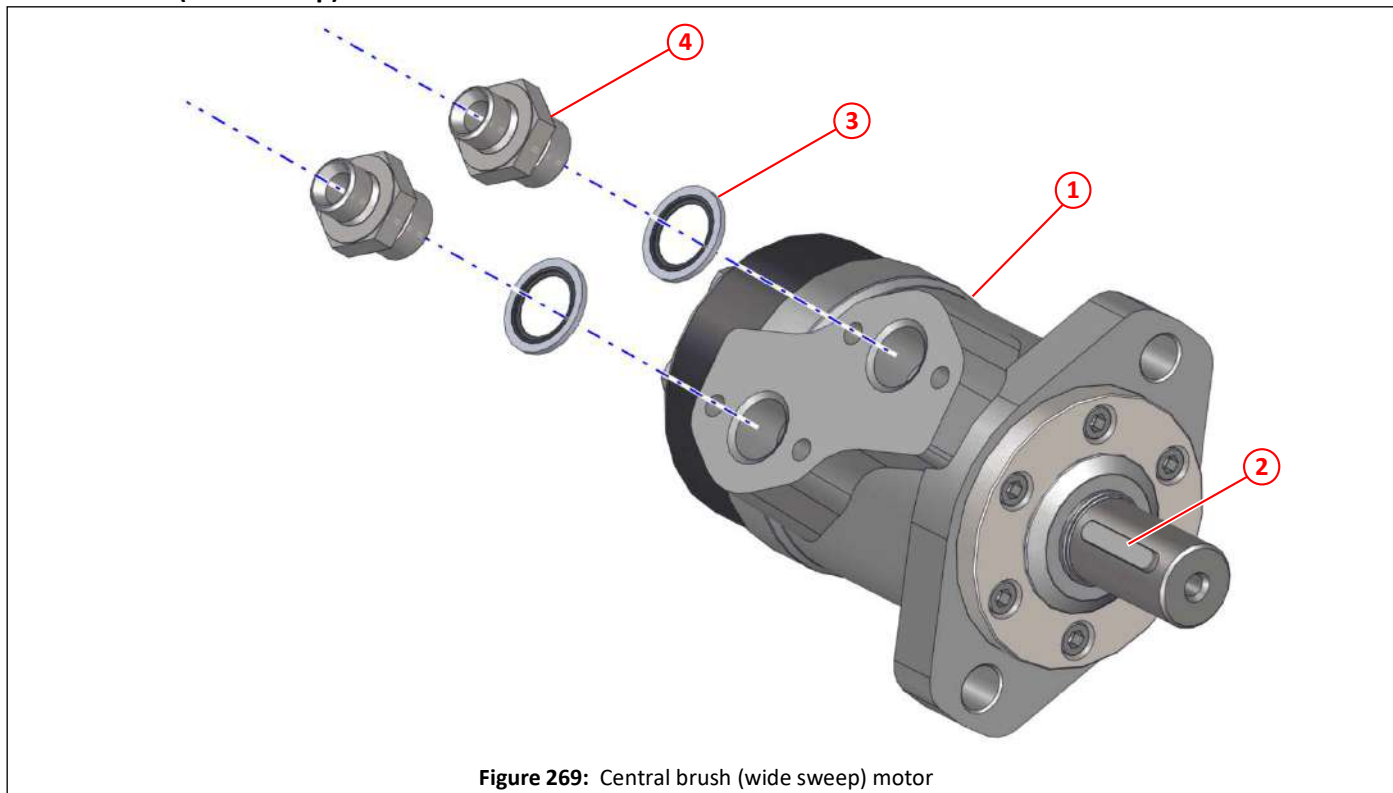

Figure 269: Central brush (wide sweep) motor

Item	Part No	Qty	Description	
①	010566	1	Motor 3596 (OMP 100)	72
②	011515	1	Key for motor	
③	011154	2	Dowty seal $\frac{1}{2}$ " BSP	
④	011167	2	Adapter $\frac{1}{2}$ " x $\frac{3}{8}$ " BSP	

Low pressure water pump motor

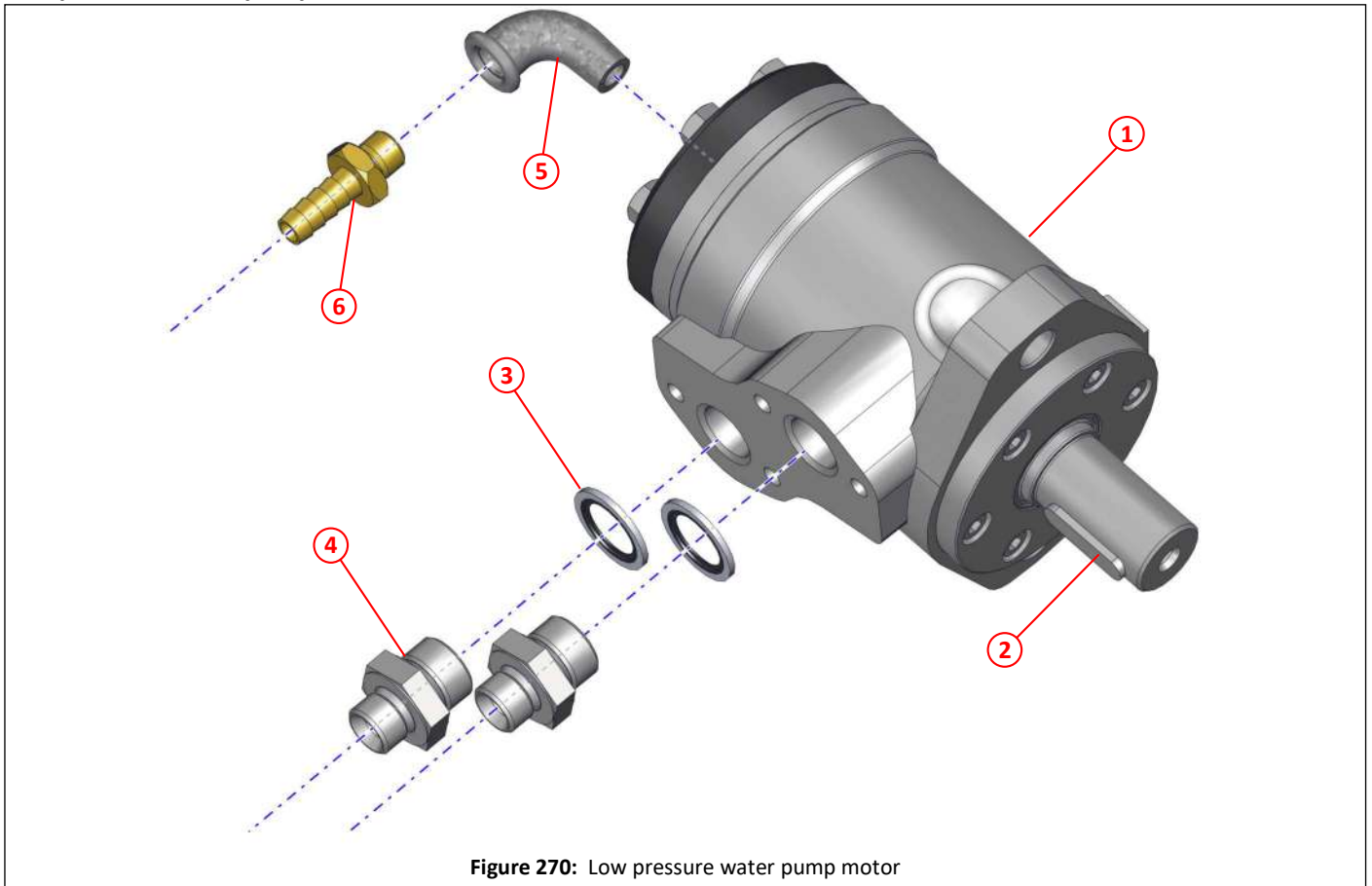

Figure 270: Low pressure water pump motor

Item	Part No	Qty	Description	
①	043778	1	Motor 40cc	33,36,54,57
②	011515	1	Key for motor	
③	011154	2	Dowty seal $\frac{1}{2}$ " BSP	
④	011167	2	Adapter $\frac{1}{2}$ " x $\frac{3}{8}$ " BSP	
⑤	010910	1	Elbow, $\frac{1}{4}$ " BSP, male/female	
⑥	010922	1	Adapter $\frac{1}{4}$ " BSP x $\frac{3}{8}$ " hose tail	

High pressure water pump motor

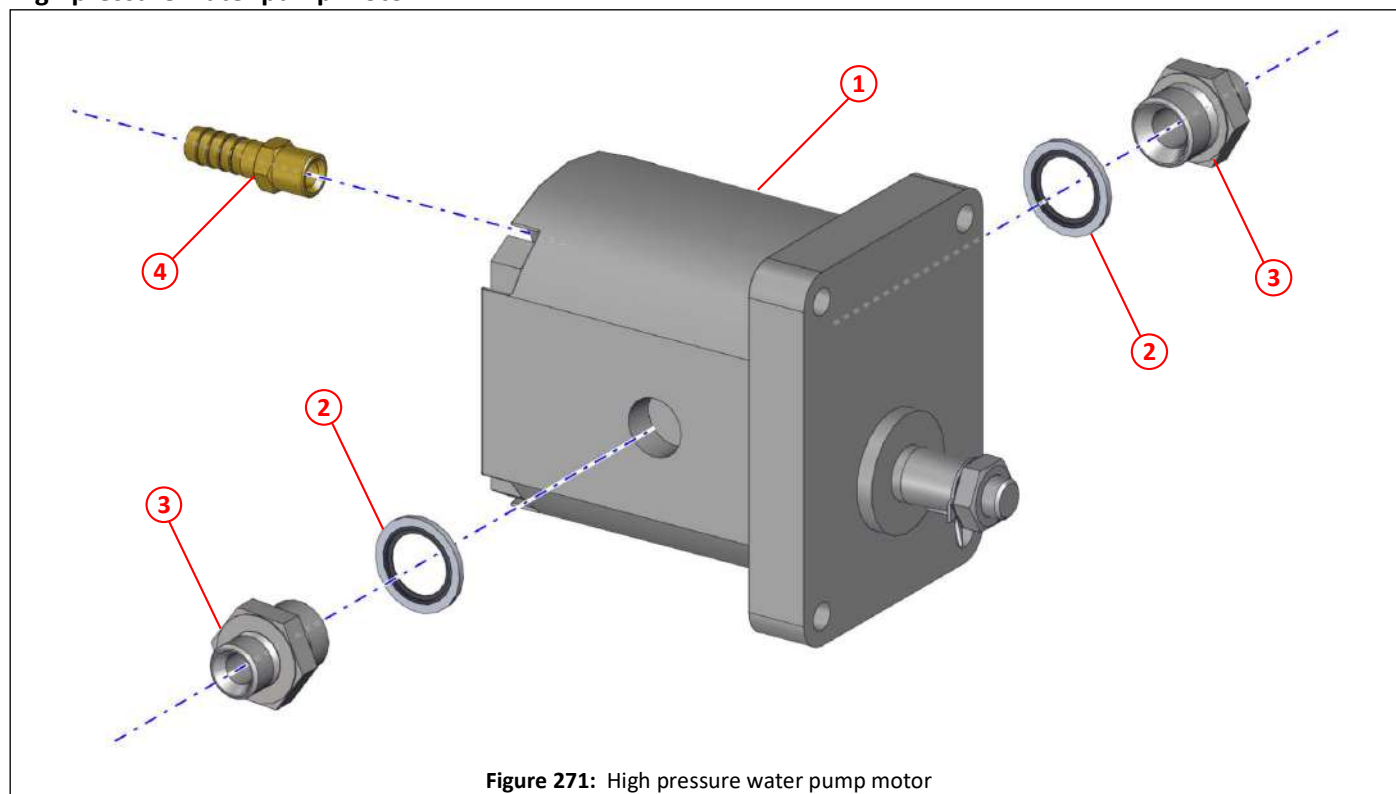

Figure 271: High pressure water pump motor

Item	Part No	Qty	Description	
①	025373	1	Motor 16cc	245
②	011154	2	Dowty seal $\frac{1}{2}$ " BSP	
③	011167	2	Adapter $\frac{1}{2}$ " x $\frac{3}{8}$ " BSP	
④	003010	1	Adapter $\frac{1}{4}$ " BSPT x $\frac{3}{8}$ " hose tail	

Side brush lift ram

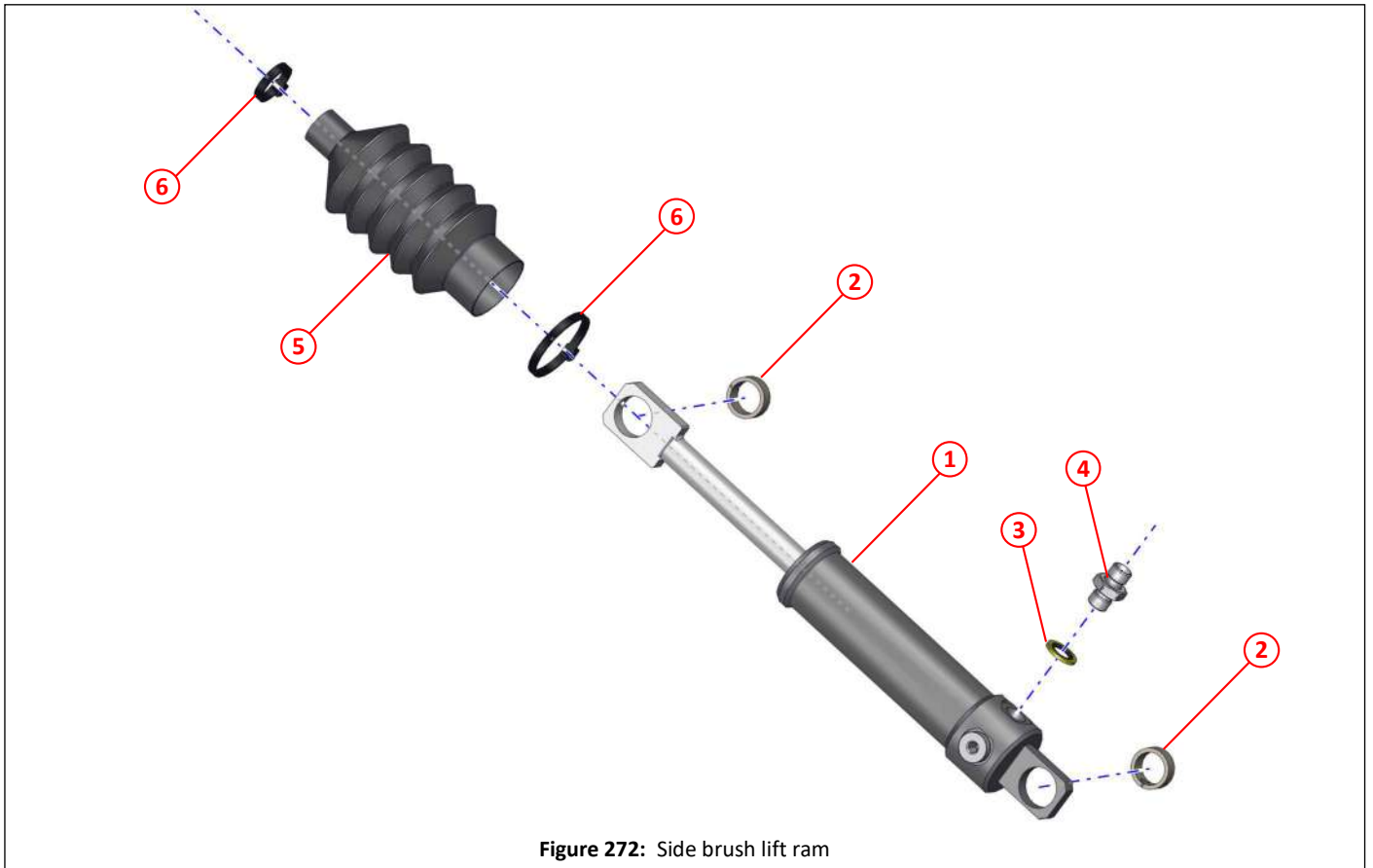

Figure 272: Side brush lift ram

Item	Part No	Qty	Description	
①	010009	1	Ram 240/340	
②	024682	2	Bush $\phi 25 \times \phi 20 \times 10$	
③	011152	1	Dowty seal $\frac{1}{4}$ " BSP	
④	012539	1	Restrictor No 5, $\frac{1}{4}$ " x $\frac{1}{4}$ " BSP, $\frac{1}{32}$ ", white	
⑤	014473	1	Bellows	
⑥	005018	2	Cable tie, black x80R	

Suction nozzle tilt ram

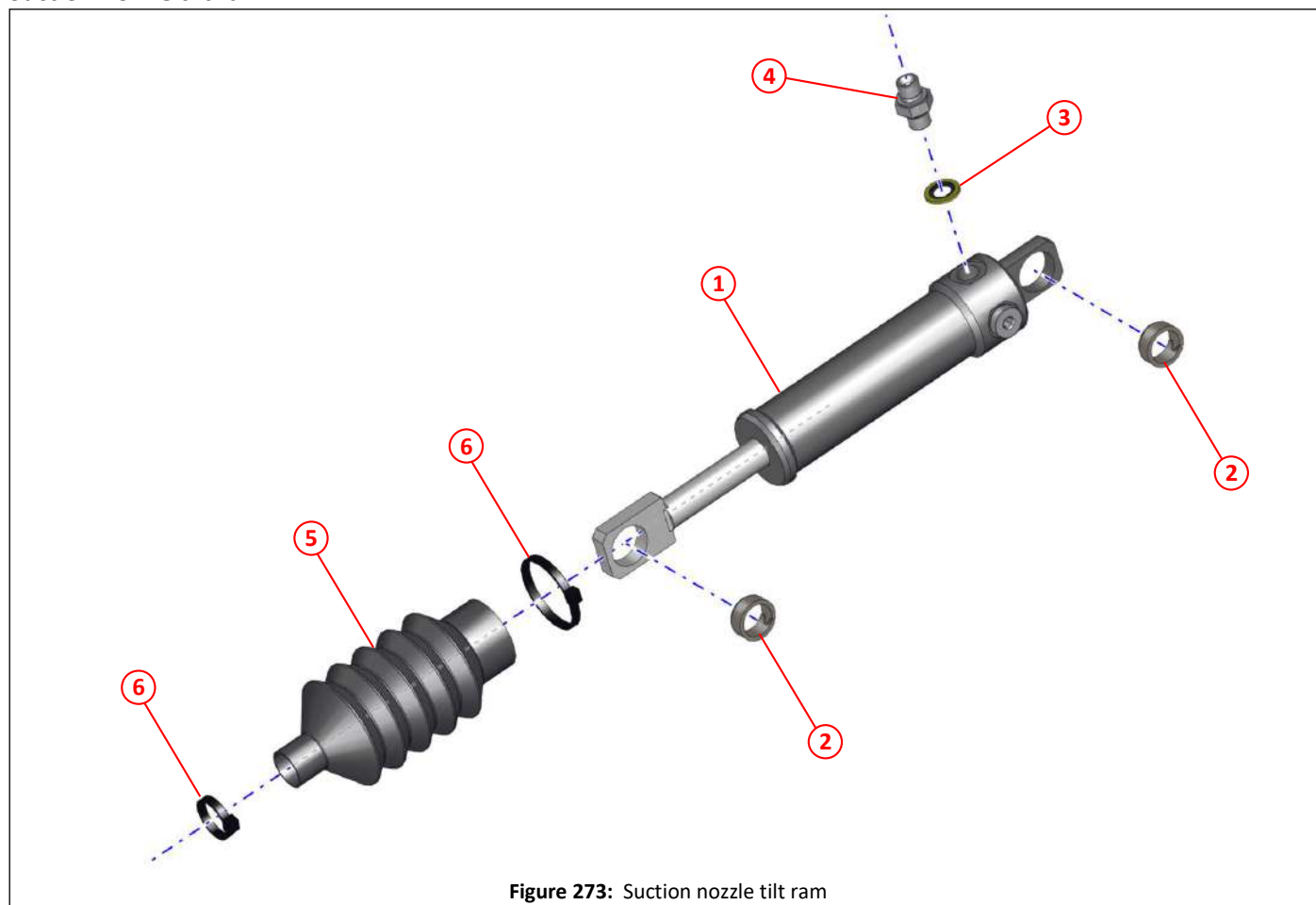

Figure 273: Suction nozzle tilt ram

Item	Part No	Qty	Description
①	041954	1	Ram No. 12, 240/340
②	024682	2	Bush $\varnothing 25 \times \varnothing 20 \times 10$
③	011152	1	Dowty seal $\frac{1}{4}$ " BSP
④	027188	1	Restrictor 0.6mm x $\frac{1}{4}$ " BSP
⑤	014473	1	Bellows
⑥	005018	2	Cable tie, black x80R

Pneumatics

<i>Description</i>	<i>Page</i>
Pneumatic control block and valves, 12V	314
Pneumatic control block and valves, 24V	316
5/2 HT spring valve body and 15mm HT solenoid valve	318
5/2 HT spring valve body	319
15mm HT solenoid valve,	320
5/2 pilot/pilot HT valve	321
5/3 pilot/pilot HT valve	322
Valve, OR gate	323
Seals and gaskets	324
Breather and relief valves	325
Air purge valve	326
Pressure regulator valve and gauge, central brush (wide sweep)	327
Brush pressure valve, gauge and controls - Typical arrangement in the Cab	328
Pneumatic air regulator and filter	329
Pneumatic cylinder, central brush (wide sweep) raise/lower	330
Pneumatic cylinder, central brush (wide sweep) slew	331
Pneumatic cylinder, side brush swing in/out	332
Pneumatic cylinder, side brush pressure	333
Pneumatic cylinder, suction nozzle raise/lower	334
Pneumatic cylinder, auto blanking	335
Pneumatic cylinder, hopper safety prop, kicker	336

Pneumatic control block and valves, 12V

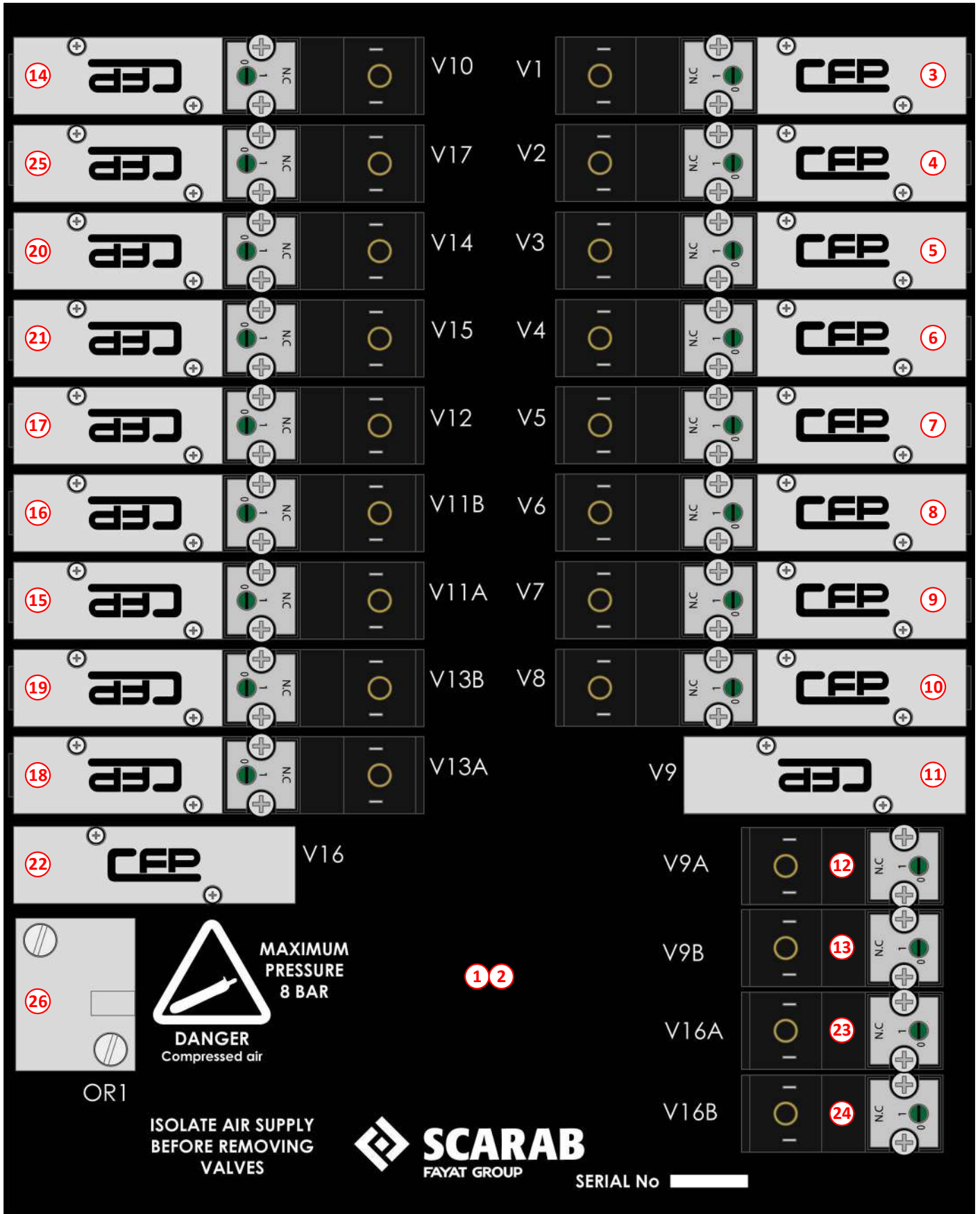

Figure 274: Pneumatic control block and valves, 12V

Item	Part No	Qty	Description
①	045303	1	Pneumatic control block (HAF), populated, 12V
②	045474	1	Pneumatic control block (HAF), bare
③	045406	1	V1 - 5/2 HT solenoid & spring valve 12V, LH side brush in/out
④	045406	1	V2 - 5/2 HT solenoid & spring valve 12V, LH suction nozzle lift/lower
⑤	045406	1	V3 - 5/2 HT solenoid & spring valve 12V, LH auto blanking flap open/close
⑥	045406	1	V4 - 5/2 HT solenoid & spring valve 12V, RH auto blanking flap open/close
⑦	045406	1	V5 - 5/2 HT solenoid & spring valve 12V, RH suction nozzle open/close
⑧	045406	1	V6 - 5/2 HT solenoid & spring valve 12V, RH side brush in/out
⑨	045406	1	V7 - 5/2 HT solenoid & spring valve 12V, central brush (wide sweep) swivel/slew
⑩	045406	1	V8 - 5/2 HT solenoid & spring valve 12V, rear boom flap
⑪	045383	1	V9 - 5/2 HT pilot/pilot valve, full pressure side brush
⑫	045382	1	V9A - 5/2 HT 15mm solenoid 12V, full pressure side brush down
⑬	045382	1	V9B - 5/2 HT 15mm solenoid 12V, full pressure side brush up
⑭	045406	1	V10 - 5/2 HT solenoid & spring valve 12V, hopper prop
⑮	045406	1	V11A - 5/2 HT solenoid & spring valve 12V, side brush pressure up
⑯	045406	1	V11B - 5/2 HT solenoid & spring valve 12V, side brush pressure down
⑰	045406	1	V12 - 5/2 HT solenoid & spring valve 12V, central brush (wide sweep) lift/lower
⑱	045406	1	V13A - 5/2 HT solenoid & spring valve 12V, central brush (wide sweep) up pressure
⑲	045406	1	V13B - 5/2 HT solenoid & spring valve 12V, central brush (wide sweep) down pressure
⑳	045406	1	V14 - 5/2 HT solenoid & spring valve 12V, auxiliary brush slide out
㉑	045406	1	V15 - 5/2 HT solenoid & spring valve 12V, auxiliary brush lower
㉒	045384	1	V16 - 5/3 HT pilot/pilot valve, air operated rear boom
㉓	045382	1	V16A - 5/2 HT 15mm solenoid 12V, air operated rear boom raise
㉔	045382	1	V16B - 5/2 HT 15mm solenoid 12V, air operated rear boom lower
㉕	045406	1	V17 - 5/2 HT solenoid/spring valve 12V, auxiliary brush swing in/out
㉖	032710	1	OR1 - OR gate valve

Pneumatic control block and valves, 24V

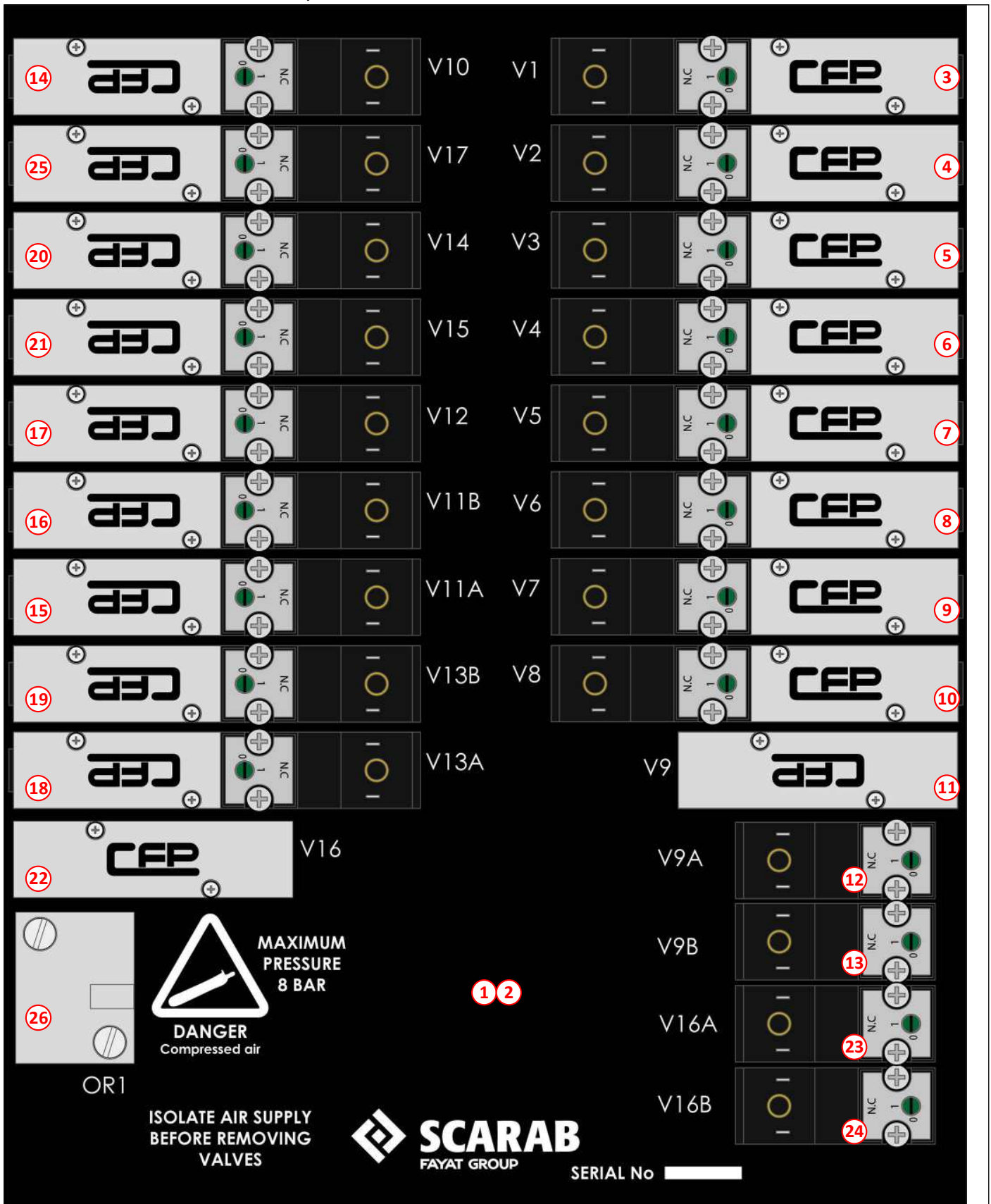

Figure 275: Pneumatic control block and valves, 24V

Item	Part No	Qty	Description
①	045293	1	Pneumatic control block (HAF), populated, 24V
②	045474	1	Pneumatic control block (HAF), bare
③	045385	1	V1 - 5/2 HT solenoid & spring valve 24V, LH side brush in/out
④	045385	1	V2 - 5/2 HT solenoid & spring valve 24V, LH suction nozzle lift/lower
⑤	045385	1	V3 - 5/2 HT solenoid & spring valve 24V, LH auto blanking flap open/close
⑥	045385	1	V4 - 5/2 HT solenoid & spring valve 24V, RH auto blanking flap open/close
⑦	045385	1	V5 - 5/2 HT solenoid & spring valve 24V, RH suction nozzle open/close
⑧	045385	1	V6 - 5/2 HT solenoid & spring valve 24V, RH side brush in/out
⑨	045385	1	V7 - 5/2 HT solenoid & spring valve 24V, central brush (wide sweep) swivel/slew
⑩	045385	1	V8 - 5/2 HT solenoid & spring valve 24V, rear boom flap
⑪	045383	1	V9 - 5/2 HT pilot/pilot valve, full pressure side brush
⑫	045381	1	V9A - 5/2 HT 15mm solenoid 24V, full pressure side brush down
⑬	045381	1	V9B - 5/2 HT 15mm solenoid 24V, full pressure side brush up
⑭	045385	1	V10 - 5/2 HT solenoid & spring valve 24V, hopper prop
⑮	045385	1	V11A - 5/2 HT solenoid & spring valve 24V, side brush pressure up
⑯	045385	1	V11B - 5/2 HT solenoid & spring valve 24V, side brush pressure down
⑰	045385	1	V12 - 5/2 HT solenoid & spring valve 24V, central brush (wide sweep) lift/lower
⑱	045385	1	V13A - 5/2 HT solenoid & spring valve 24V, central brush (wide sweep) up pressure
⑲	045385	1	V13B - 5/2 HT solenoid & spring valve 24V, central brush (wide sweep) down pressure
⑳	045385	1	V14 - 5/2 HT solenoid & spring valve 24V, auxiliary brush slide out
㉑	045385	1	V15 - 5/2 HT solenoid & spring valve 24V, auxiliary brush lower
㉒	045384	1	V16 - 5/3 HT pilot/pilot valve, air operated rear boom
㉓	045381	1	V16A - 5/2 HT 15mm solenoid 24V, air operated rear boom raise
㉔	045381	1	V16B - 5/2 HT 15mm solenoid 24V, air operated rear boom lower
㉕	045385	1	V17 - 5/2 HT solenoid/spring valve 24V, auxiliary brush swing in/out
㉖	032710	1	OR1 - OR gate valve

5/2 HT spring valve body and 15mm HT solenoid valve

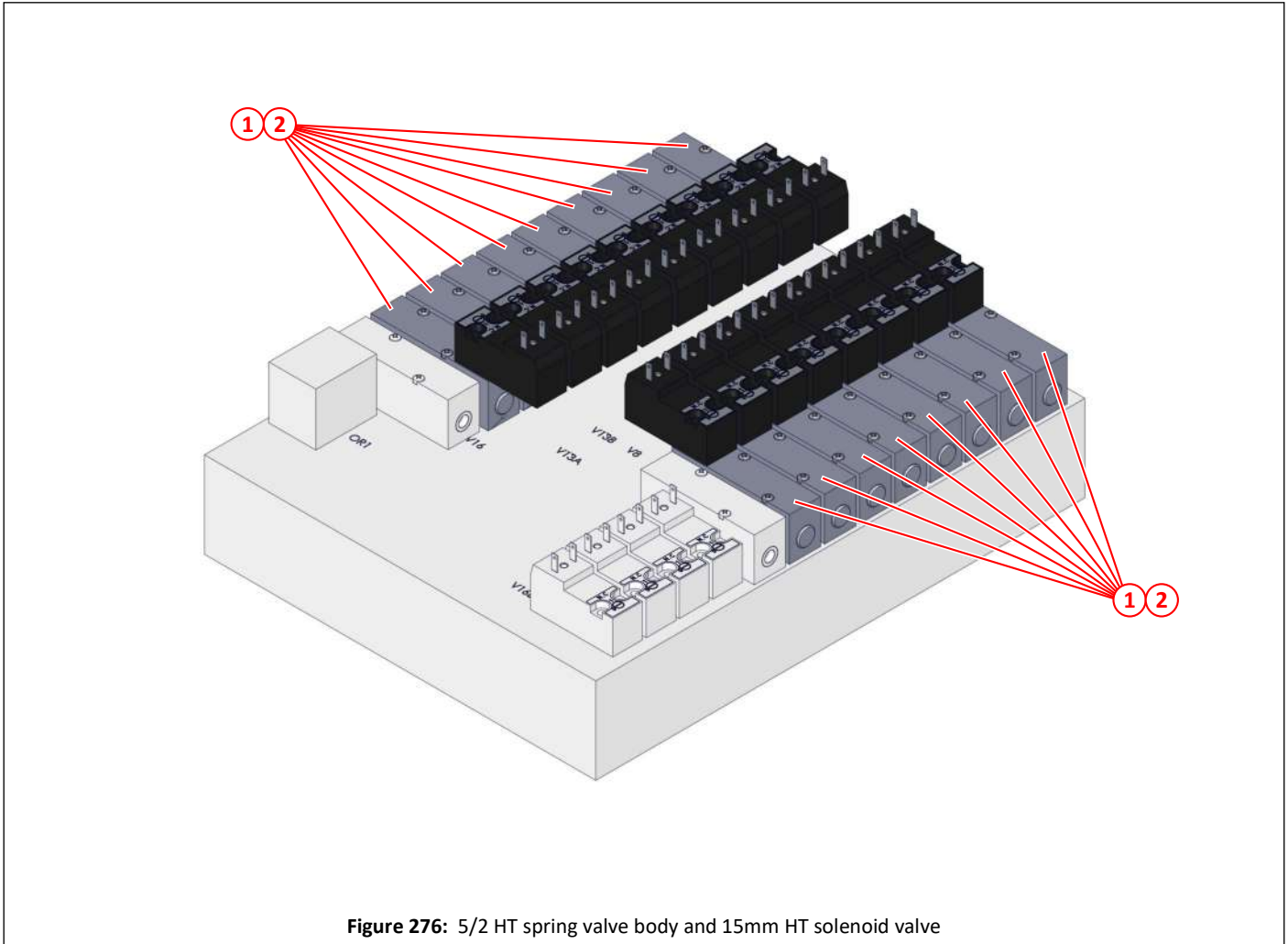

Figure 276: 5/2 HT spring valve body and 15mm HT solenoid valve

Item	Part No	Qty	Description	
①	045406	17	5/2 HT spring valve body and 15mm HT solenoid valve, 12V	
②	045385	17	5/2 HT spring valve body and 15mm HT solenoid valve, 24V	

5/2 HT spring valve body

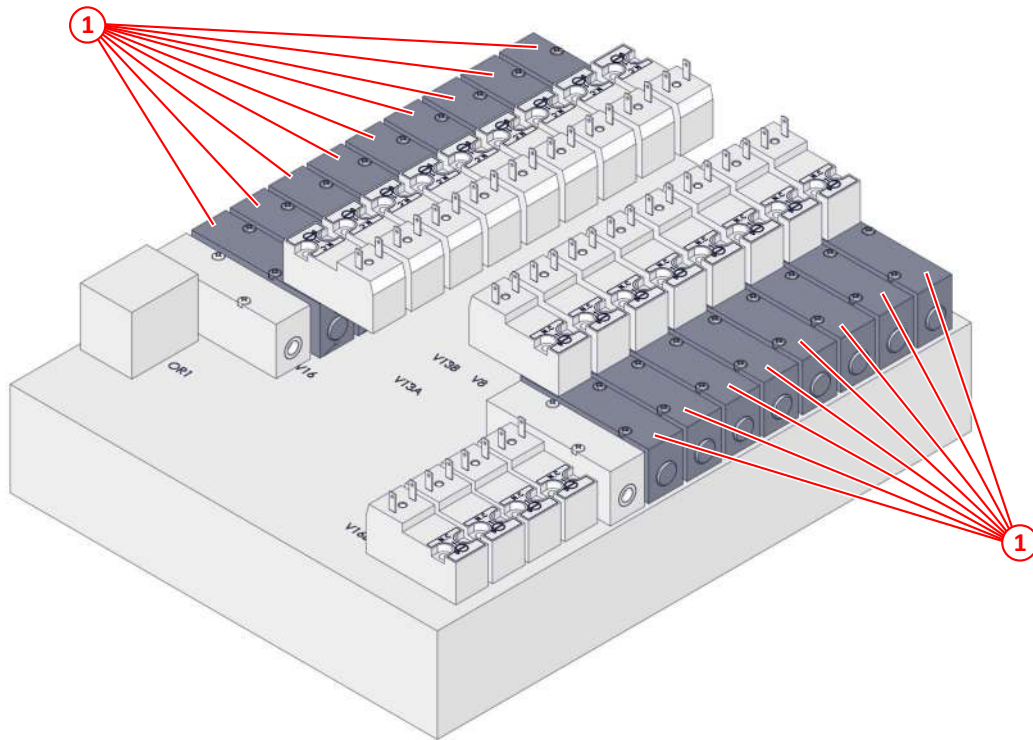

Figure 277: 5/2 HT spring valve body

Item	Part No	Qty	Description	
①	045386	17	5/2 HT spring valve body	

15mm HT solenoid valve,

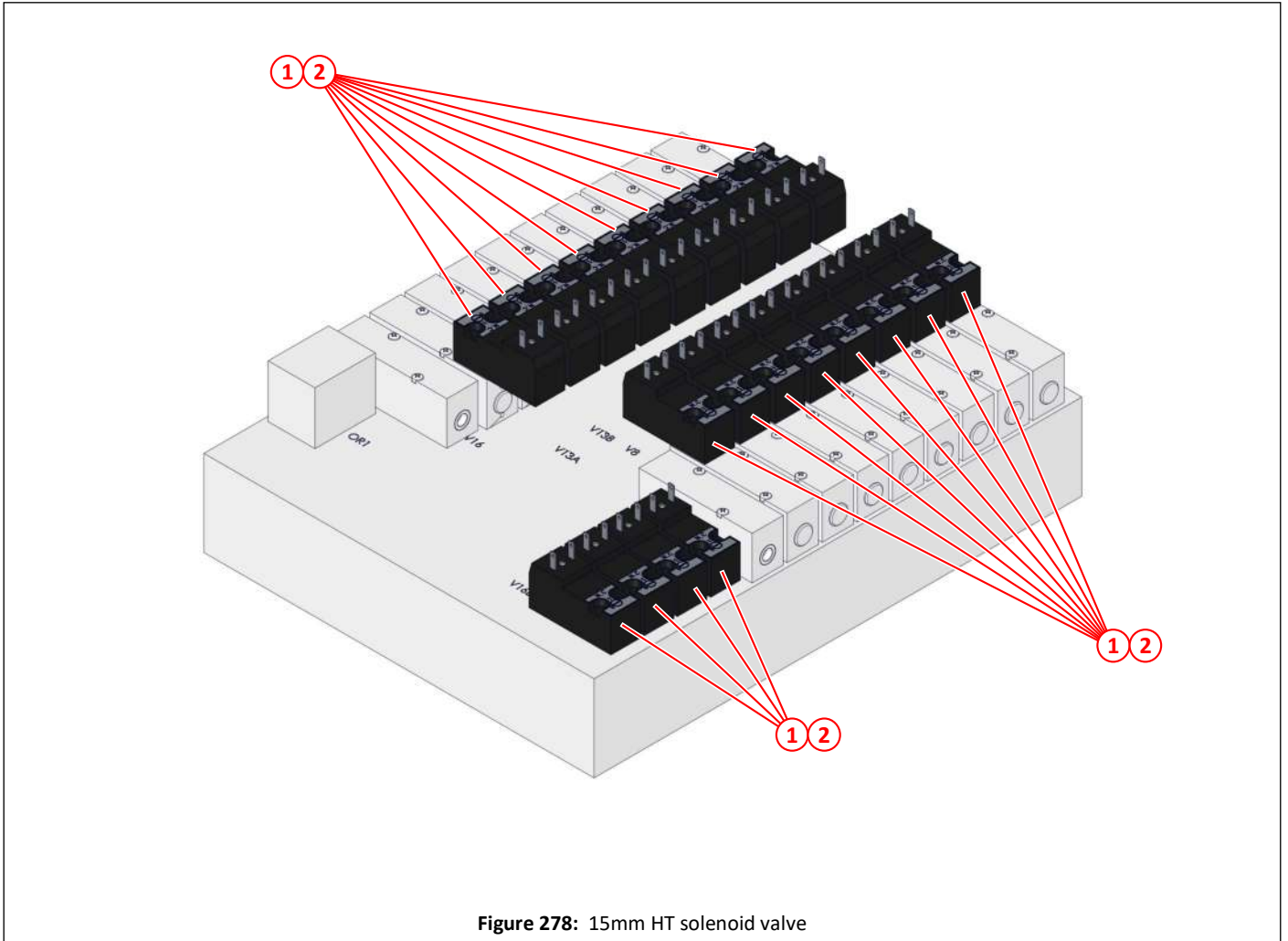

Figure 278: 15mm HT solenoid valve

Item	Part No	Qty	Description	
①	045382	21	15mm HT solenoid valve, 12V	
②	045381	21	15mm HT solenoid valve, 24V	

5/2 pilot/pilot HT valve

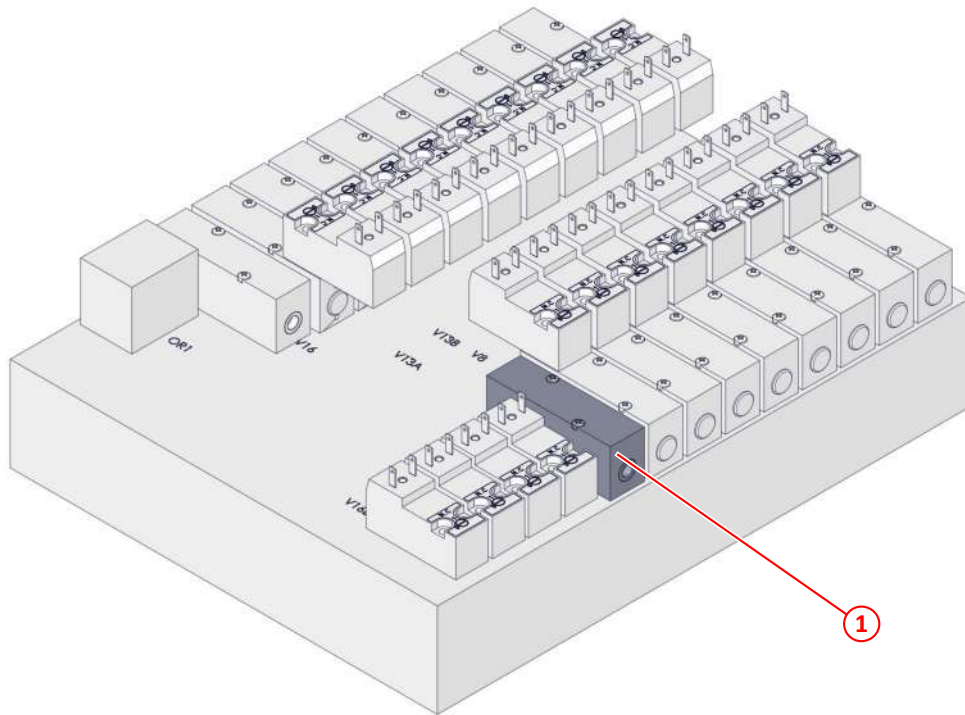

Figure 279: 5/2 pilot/pilot HT valve

Item	Part No	Qty	Description	
①	045383	1	5/2 pilot/pilot HT valve	

5/3 pilot/pilot HT valve

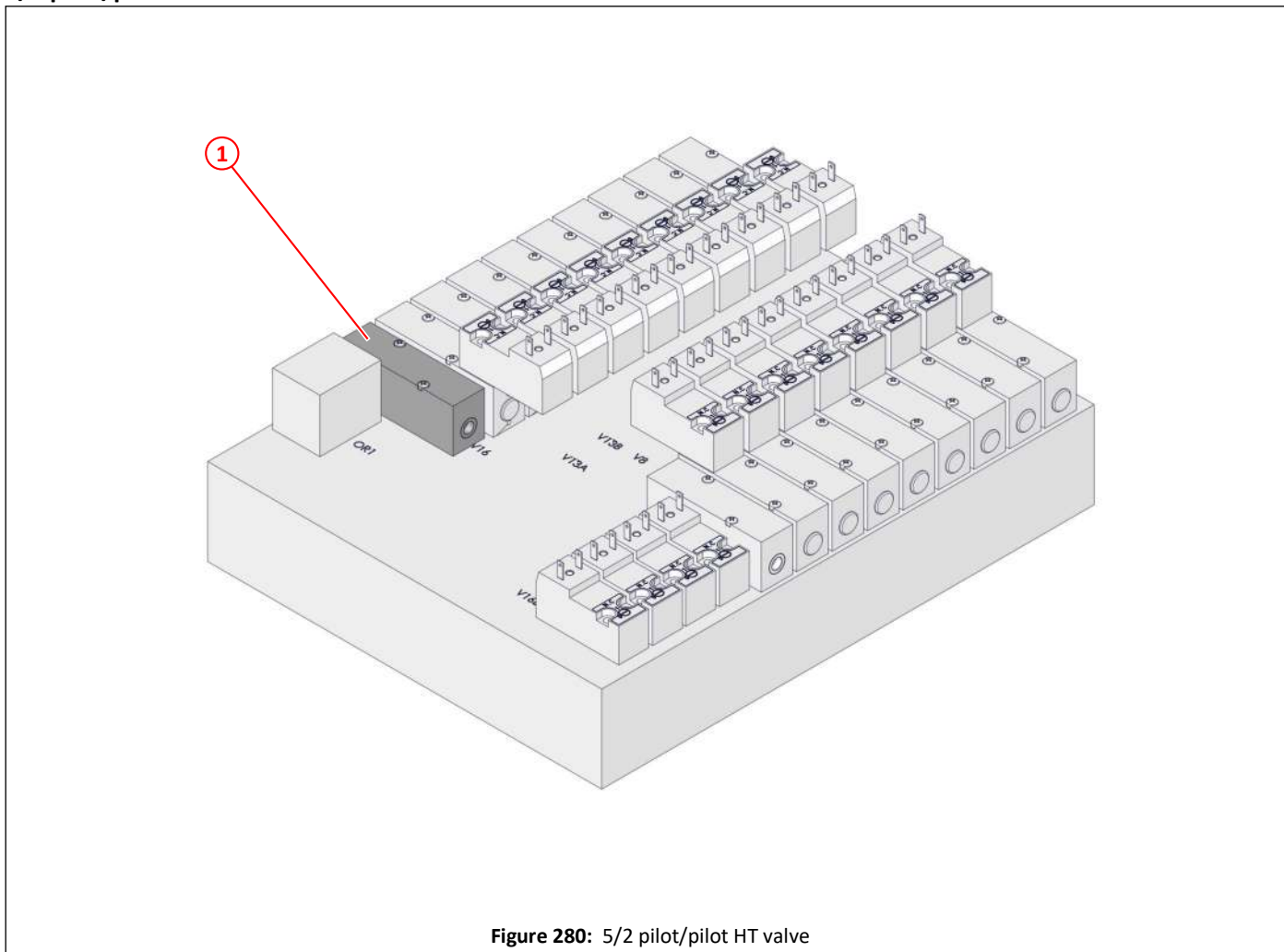

Figure 280: 5/2 pilot/pilot HT valve

Item	Part No	Qty	Description	
①	045384	1	5/3 pilot/pilot HT valve	

Valve, OR gate

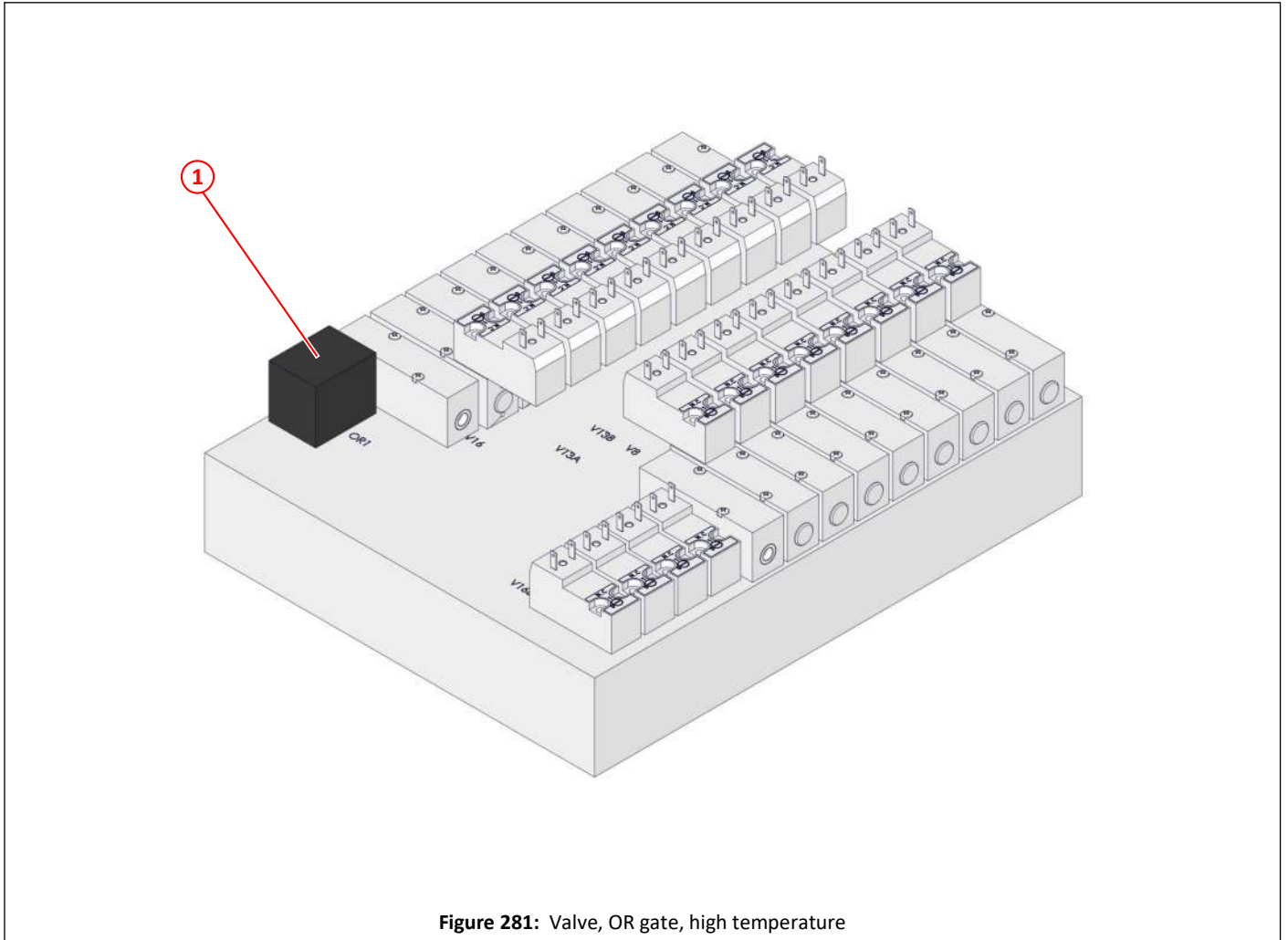

Figure 281: Valve, OR gate, high temperature

Item	Part No	Qty	Description	
①	032710	1	Valve, OR gate	

Seals and gaskets

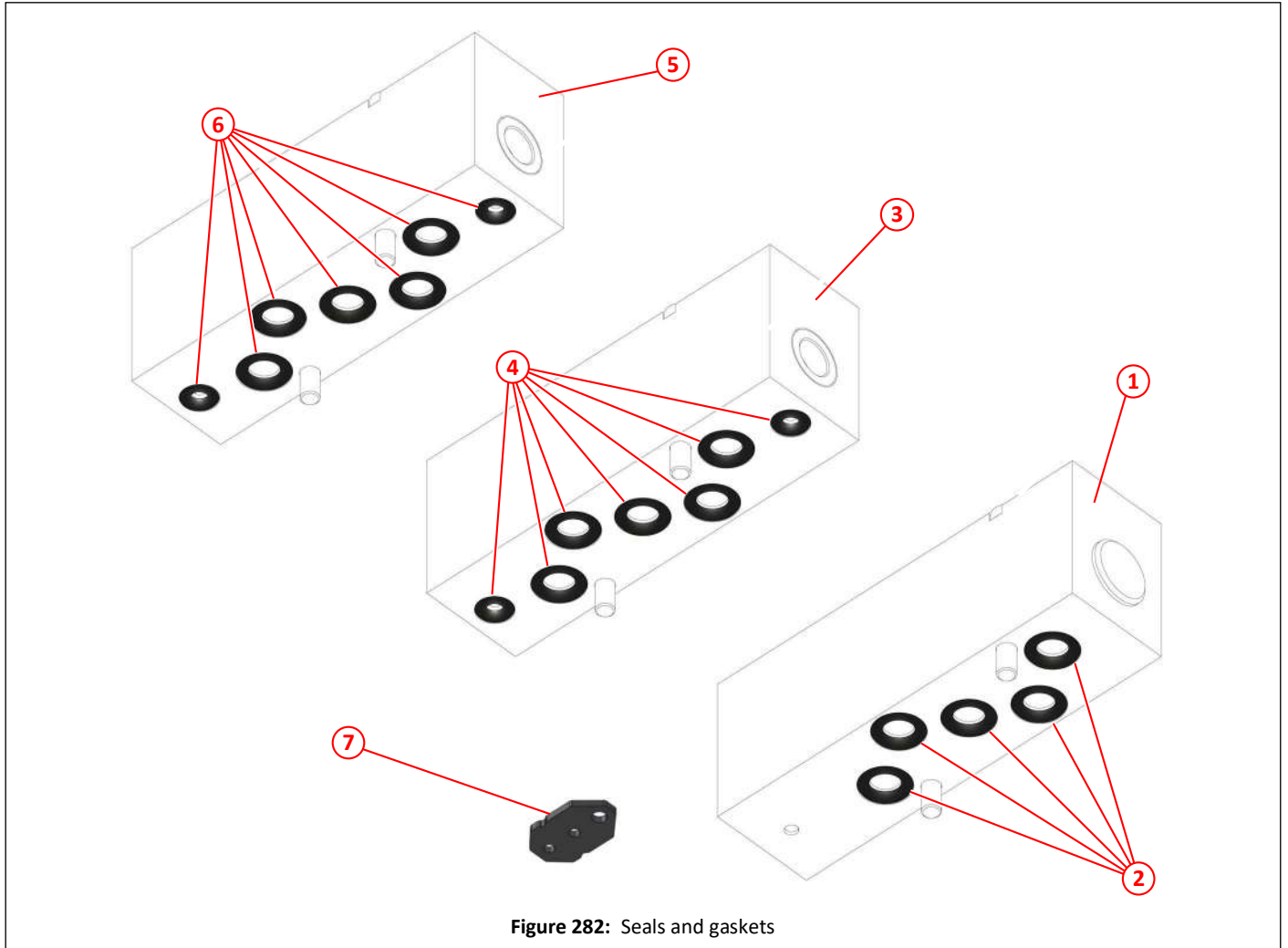

Figure 282: Seals and gaskets

Item	Part No	Qty	Description	
①	045386	17	5/2 HT spring valve body	319
②	045388	1	Seal kit for item ①, contains 5 of $\phi 4 \times \phi 1.5$ o-rings	
③	045383	1	5/2 pilot/pilot HT valve	321
④	045389	1	Seal kit for item ③, contains 5 of $\phi 4 \times \phi 1.5$ & 2 of $\phi 2 \times \phi 1.5$ o-rings	
⑤	045384	1	5/3 pilot/pilot HT valve	322
⑥	045390	1	Seal kit for item ⑤, contains 5 of $\phi 4 \times \phi 1.5$ & 2 of $\phi 2 \times \phi 1.5$ o-rings	
⑦	045387	1	Spare pilot solenoid gasket	

Breather and relief valves

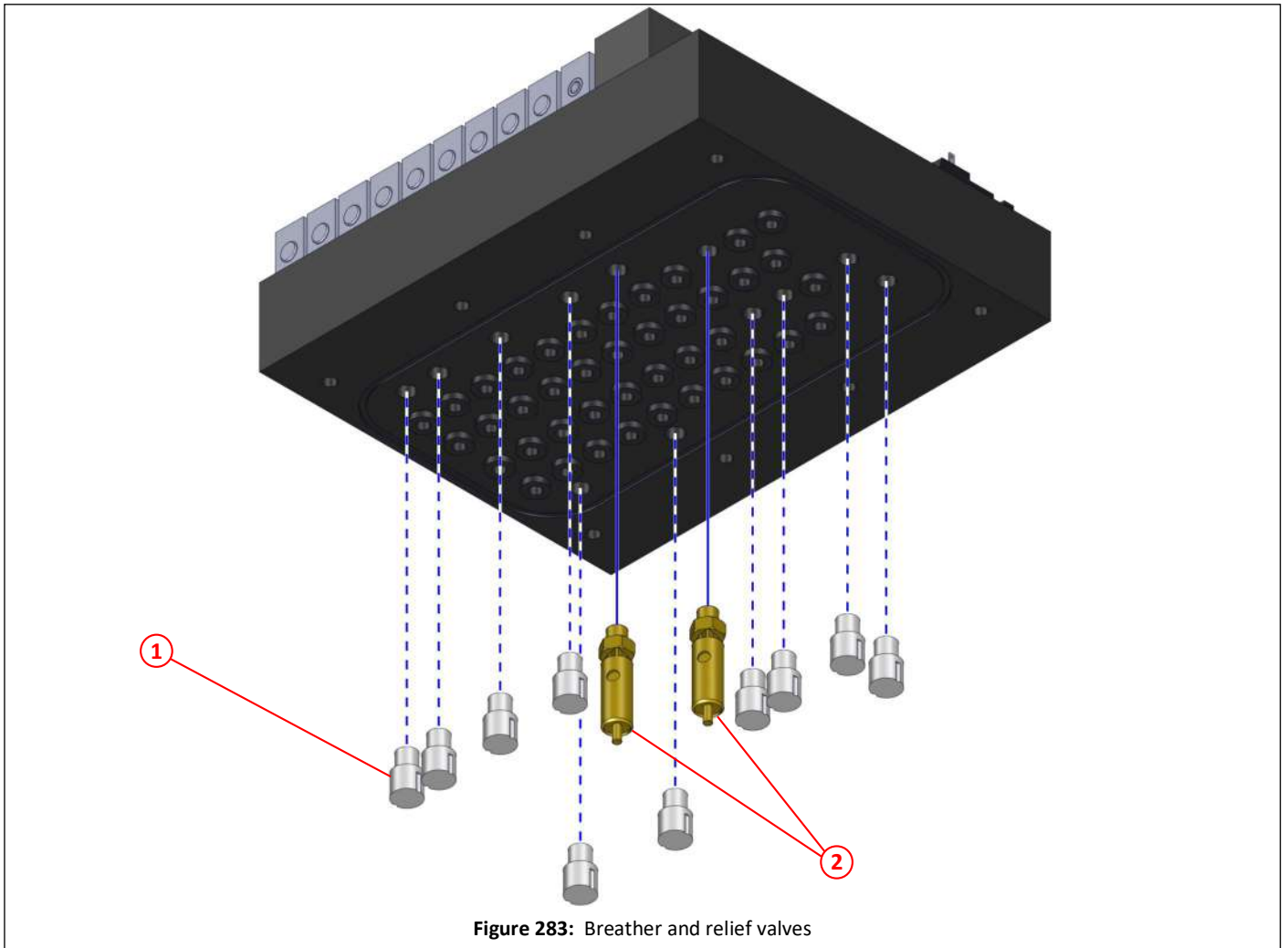

Figure 283: Breather and relief valves

Item	Part No	Qty	Description
①	006067	11	$\frac{1}{8}$ " one way breather valve
②	032709	2	Relief valve

Air purge valve

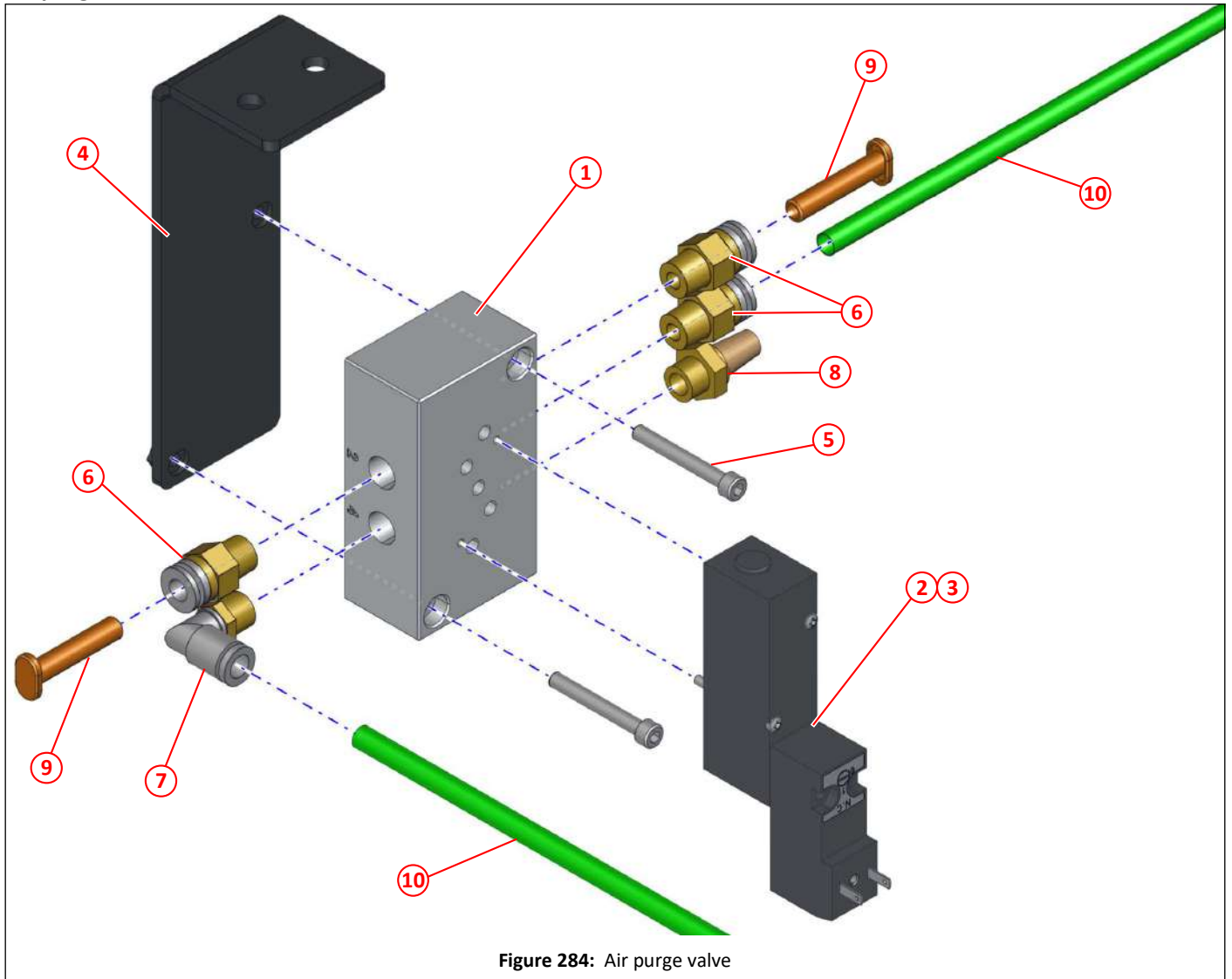

Figure 284: Air purge valve

Item	Part No	Qty	Description
①	047447	1	Air valve base plate, HAFNER
②	045406	1	5/2 HT spring valve body and 15mm HT solenoid valve, 12V
③	045385	1	5/2 HT spring valve body and 15mm HT solenoid valve, 24V
④	047811	1	Bracket, air purge valve
⑤	000525	2	Socket cap head screw M4 x 30 BZP
⑥	024643	3	Straight connector, 1/8" BSP x ø6 push in, grey
⑦	024645	1	Elbow, 1/8" BSP x ø6 push in, grey
⑧	006006	1	Muffler 1/8" BSP, NORGREN
⑨	026085	2	Plug ø6mm
⑩	024650	2	ø6mm green air pipe, cut to length as required

Pressure regulator valve and gauge, central brush (wide sweep)

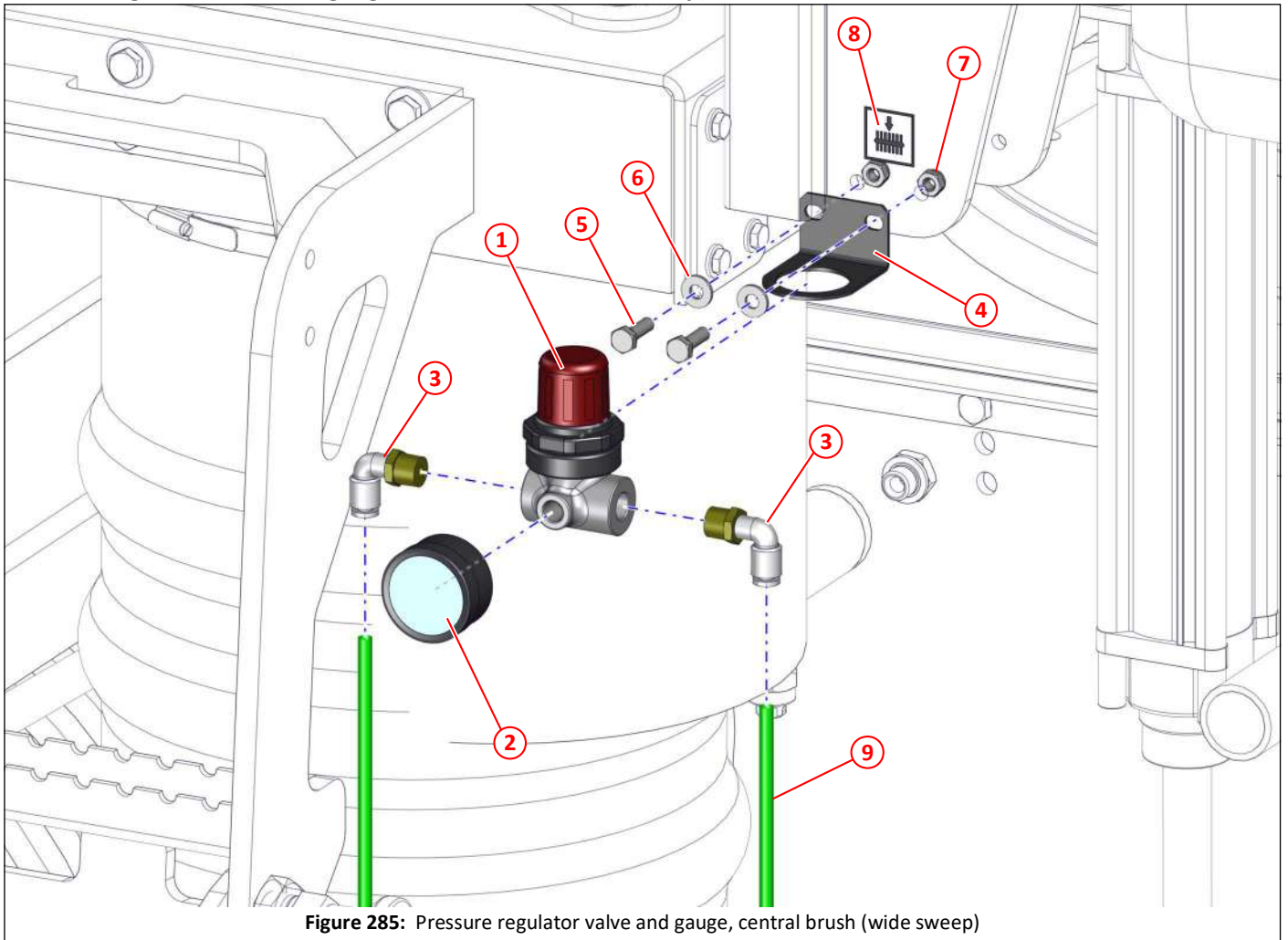
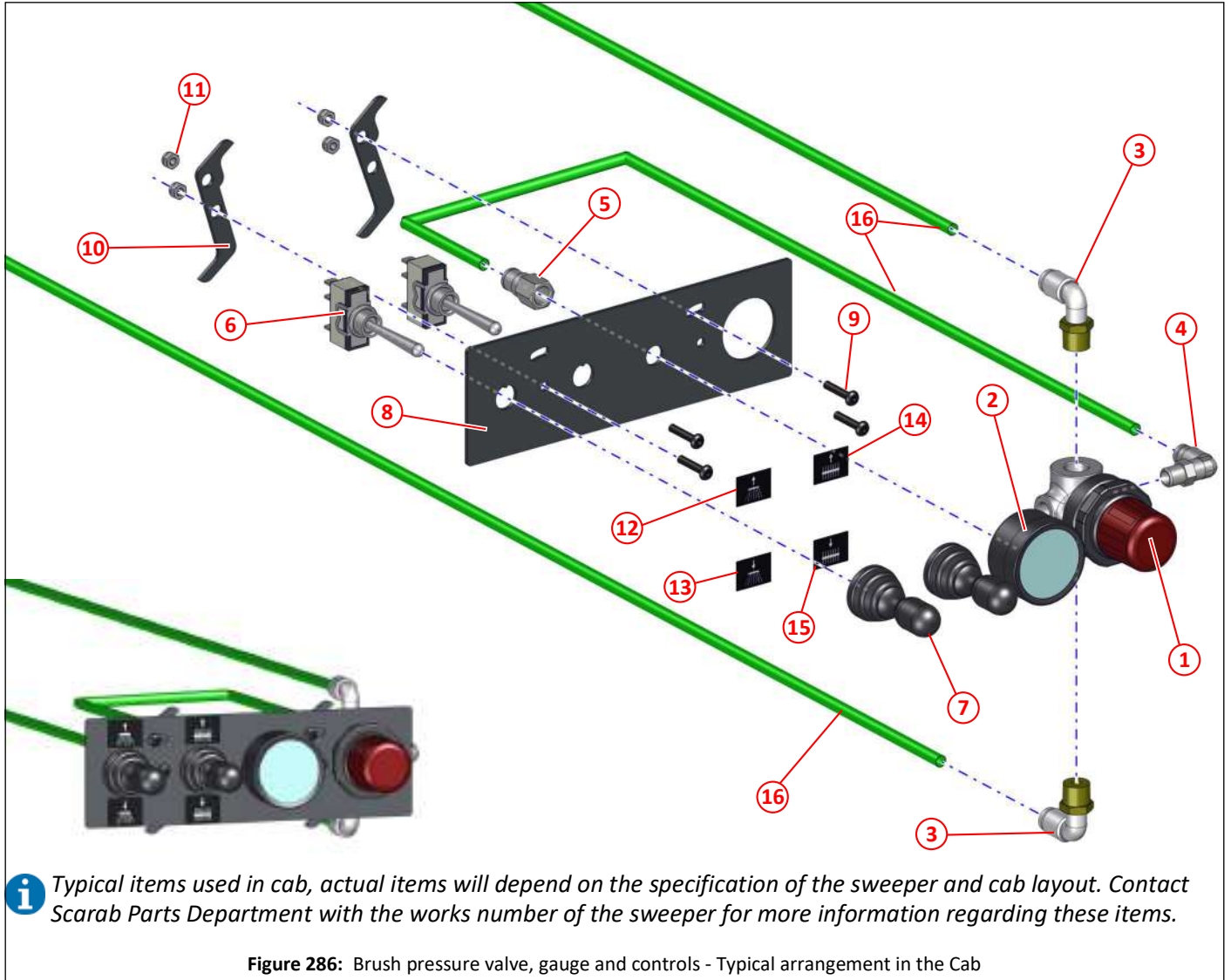

Figure 285: Pressure regulator valve and gauge, central brush (wide sweep)

Item	Part No	Qty	Description
①	023242	1	Mini pressure regulator 0.5 - 3.5bar
②	023246	1	Pressure gauge 0-10bar
③	024646	2	Elbow, swivel, plastic, 1/4" BSP x ø6 push in
④	023245	1	Bracket, mini regulator
⑤	011067	2	Setscrew M6 x 20
⑥	011090	2	Washer M6
⑦	011071	1	Nyloc nut T M6
⑧	039549	1	Label - Central brush (wide sweep) pressure down
⑨	024650	2	ø6mm green air pipe, cut to length as required
	040112	1	Air regulator brush pressure assembly, includes items ①, ②, ③, and ④

Brush pressure valve, gauge and controls - Typical arrangement in the Cab



Item	Part No	Qty	Description
①	023242	1	Mini pressure regulator 0.5 - 3.5bar
②	023246	1	Pressure gauge 0-10bar
③	024646	2	Elbow, swivel, 1/4" BSP x ø6 push in
④	006007	1	Elbow, 1/8" BSP x ø6 push in
⑤	006032	1	Adapter, 1/8" BSP x ø6 push in
⑥	037248	2	Toggle switch on/off/on
⑦	037247	2	Rubber boot for toggle switch
⑧	046628	1	Universal air regulator plate
⑨	000515	4	Socket button head set screw HD M4 x 20 black
⑩	046615	2	Clamp arm for universal air regulator plate
⑪	000134	4	Nyloc nut T M4
⑫	038117	1	Label - Side brush up pressure
⑬	038118	1	Label - Side brush down pressure
⑭	038119	1	Label - Central brush (wide sweep) up pressure
⑮	038120	1	Label - Central brush (wide sweep) down pressure
⑯	024650	3	ø6mm green air pipe, cut to length as required

Pneumatic air regulator and filter

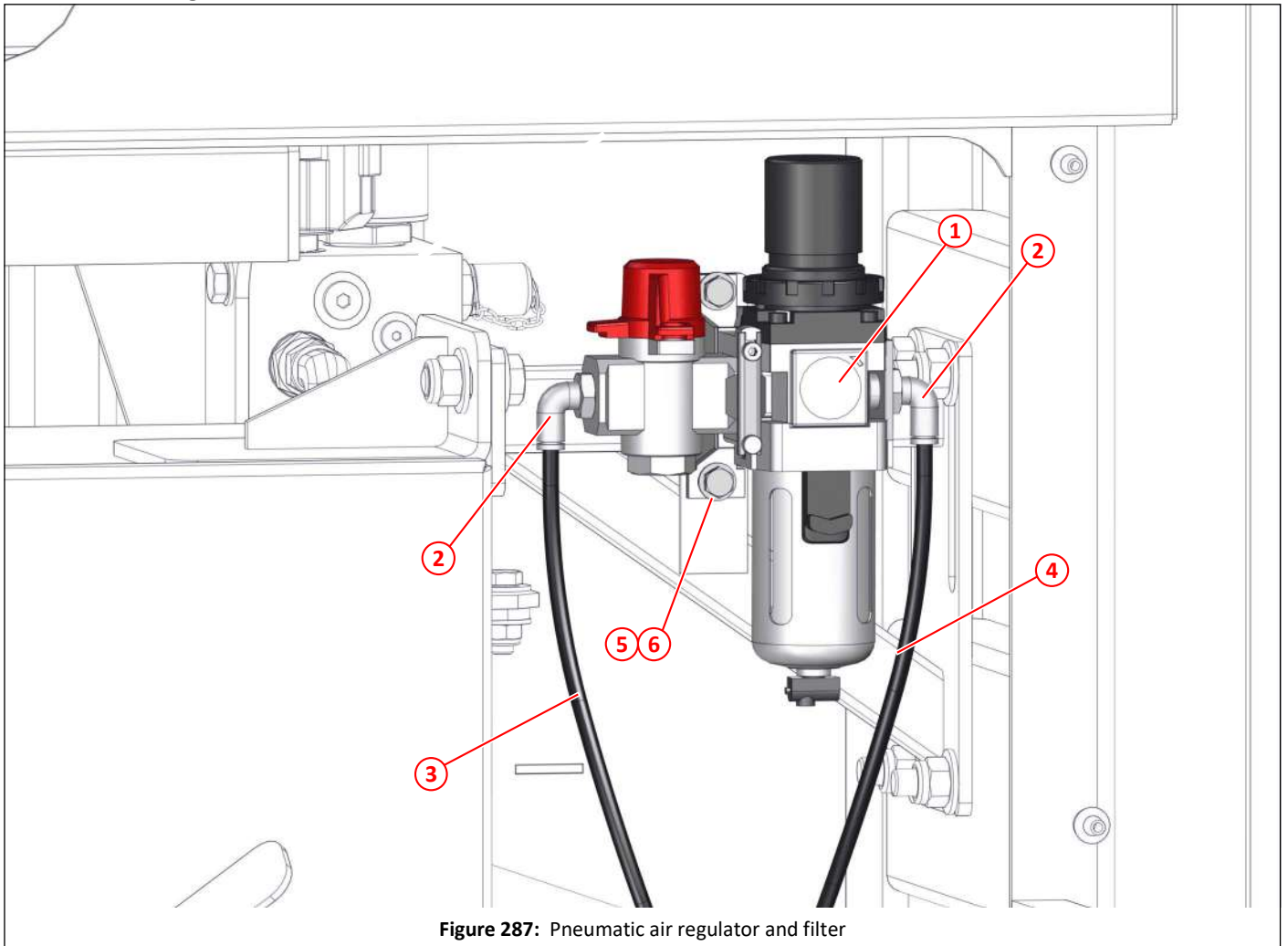

Figure 287: Pneumatic air regulator and filter

Item	Part No	Qty	Description
①	032519	1	Air regulator and filter
②	023203	2	Push in swivel elbow, $\varnothing 6 \times \frac{1}{4}$ " BSP
③	014572	1	Air pipe, black, $\varnothing 6$, main feed from chassis unit, cut to length as required
④	014572	1	Air pipe, black, $\varnothing 6$, to pneumatic valve block Port 35, cut to length as required
⑤	011067	2	Setscrew HT M6 x 20
⑥	011090	2	Washer M6

Pneumatic cylinder, central brush (wide sweep) raise/lower

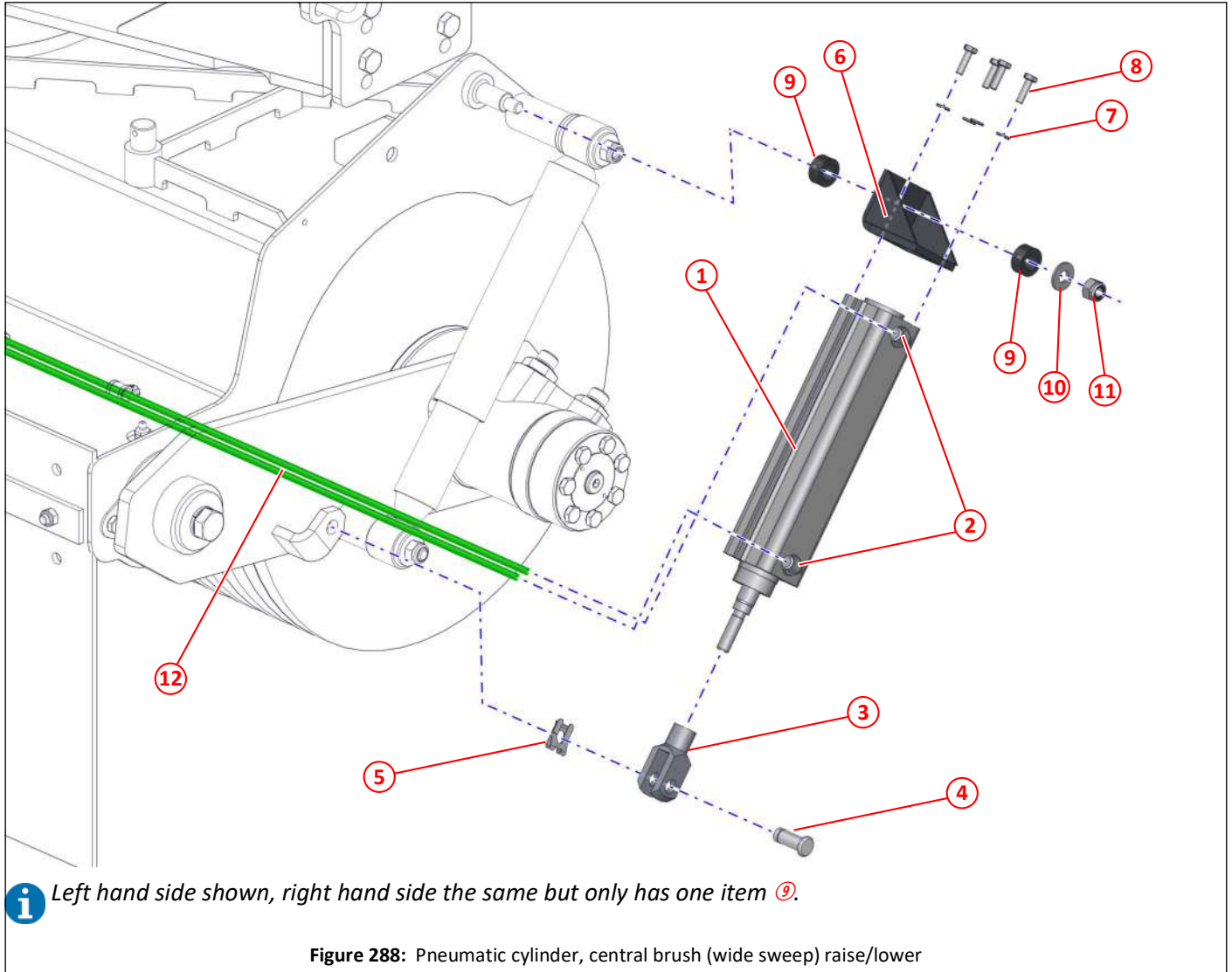

Figure 288: Pneumatic cylinder, central brush (wide sweep) raise/lower

Item	Part No	Qty	Description
①	020602	1	Pneumatic cylinder $\phi 40 \times 125$
②	023203	2	Elbow, metal, swivel, $\frac{1}{4}$ " BSP x $\phi 6$ push in
③	014469	1	Clevis, pneumatic cylinder, M12
④	023270	1	Clevis pin $\phi 12$
⑤	023269	1	Safety fastener $\phi 12$
⑥	030532	1	Bracket, pneumatic cylinder, central brush (wide sweep) raise/lower
⑦	011091	4	Spring washer M6
⑧	011067	4	Setscrew HT M6 x 20
⑨	011000	2	Rubber bush cut from, hose $\frac{5}{8}$ " fuel SAE100R6, cut to 11mm
⑩	011094	1	Washer M10
⑪	011075	1	Nyloc nut T M10
⑫	024650	2	$\phi 6$ mm green air pipe, cut to length as required

Pneumatic cylinder, central brush (wide sweep) slew

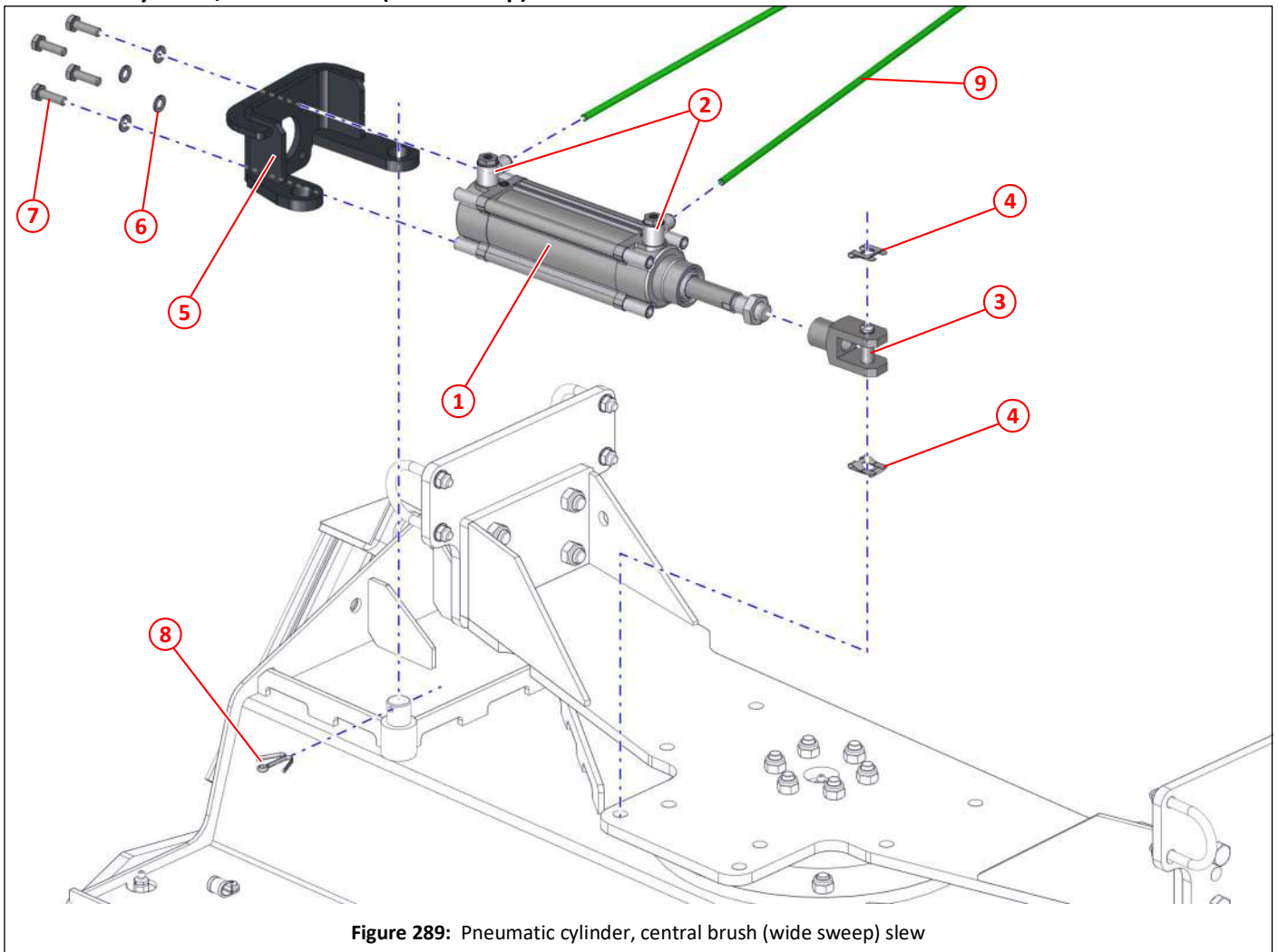
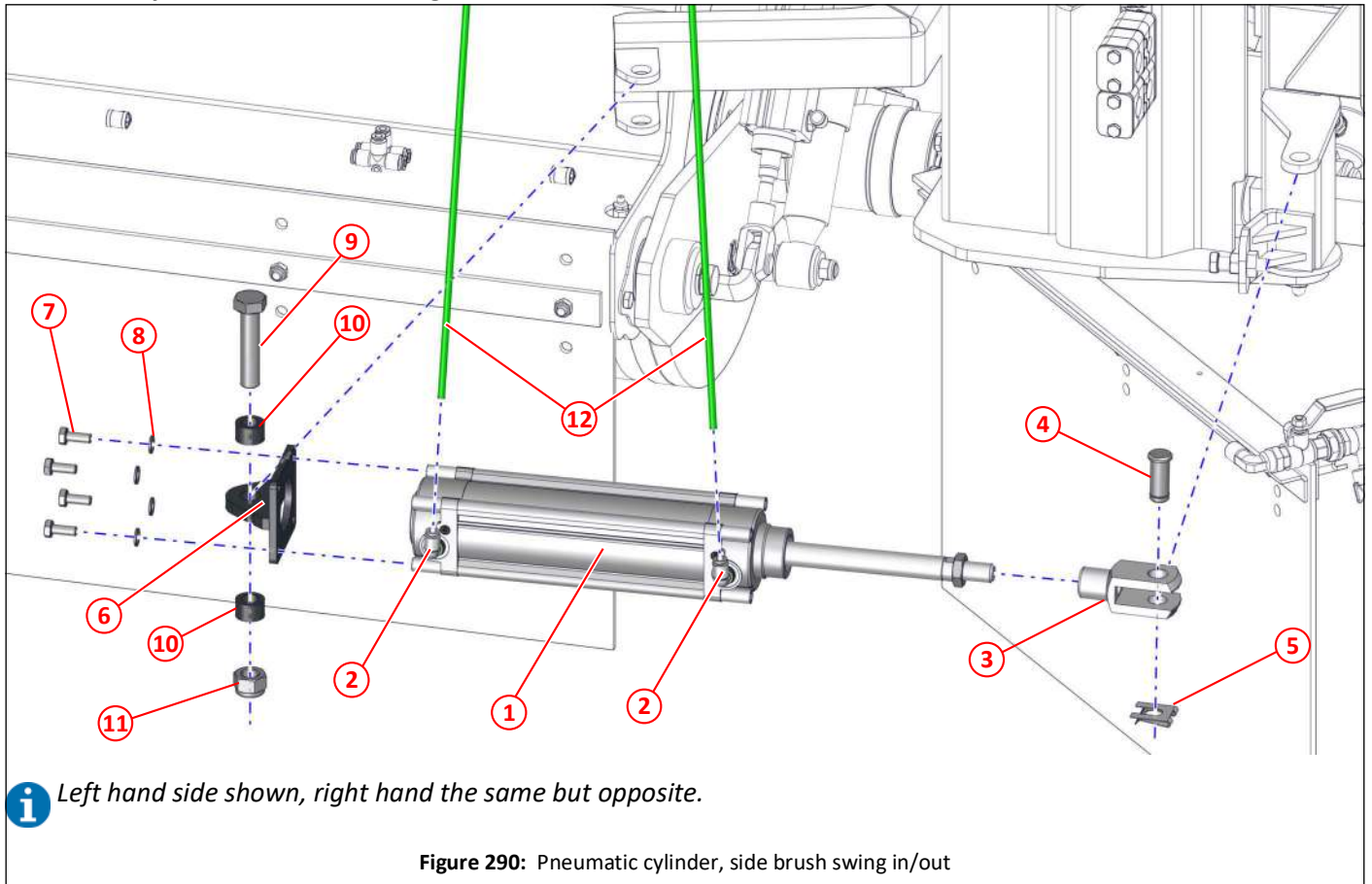

Figure 289: Pneumatic cylinder, central brush (wide sweep) slew

Item	Part No	Qty	Description
①	020767	1	Pneumatic cylinder $\varnothing 50 \times 100$
②	021158	2	Pneumatic flow regulator
③	036621	1	Clevis, special, M16 with $\varnothing 12$ pin
④	023269	2	Safety fastener $\varnothing 12$
⑤	036620	1	Bracket, pneumatic cylinder, central brush (wide sweep) slew
⑥	011093	4	Spring washer M8
⑦	011011	4	Setscrew HT M8
⑧	011122	1	Split pin, $\frac{3}{16}$ " x $1\frac{1}{2}$ "
⑨	024650	2	$\varnothing 6$ mm green air pipe, cut to length as required

Pneumatic cylinder, side brush swing in/out



Item	Part No	Qty	Description
①	028306	1	Pneumatic cylinder $\phi 63 \times 160$
②	023203	2	Elbow, metal, swivel, $\frac{1}{4}$ " BSP x $\phi 6$ push in
③	020299	1	Clevis pneumatic M16 x 1.5
④	022673	1	Clevis pin turned
⑤	022674	1	Clip retaining M16
⑥	031052	1	Ram end $\phi 63$
⑦	011010	4	Setscrew HT M8 x 20
⑧	011093	4	Spring washer M8
⑨	011260	1	Bolt HT M16 x 70
⑩	011000	2	Rubber bush cut from, hose $\frac{5}{8}$ " fuel SAE100R6, cut to 15mm
⑪	011060	1	Nyloc nut T M16
⑫	024650	2	$\phi 6$ mm green air pipe, cut to length as required

Pneumatic cylinder, side brush pressure

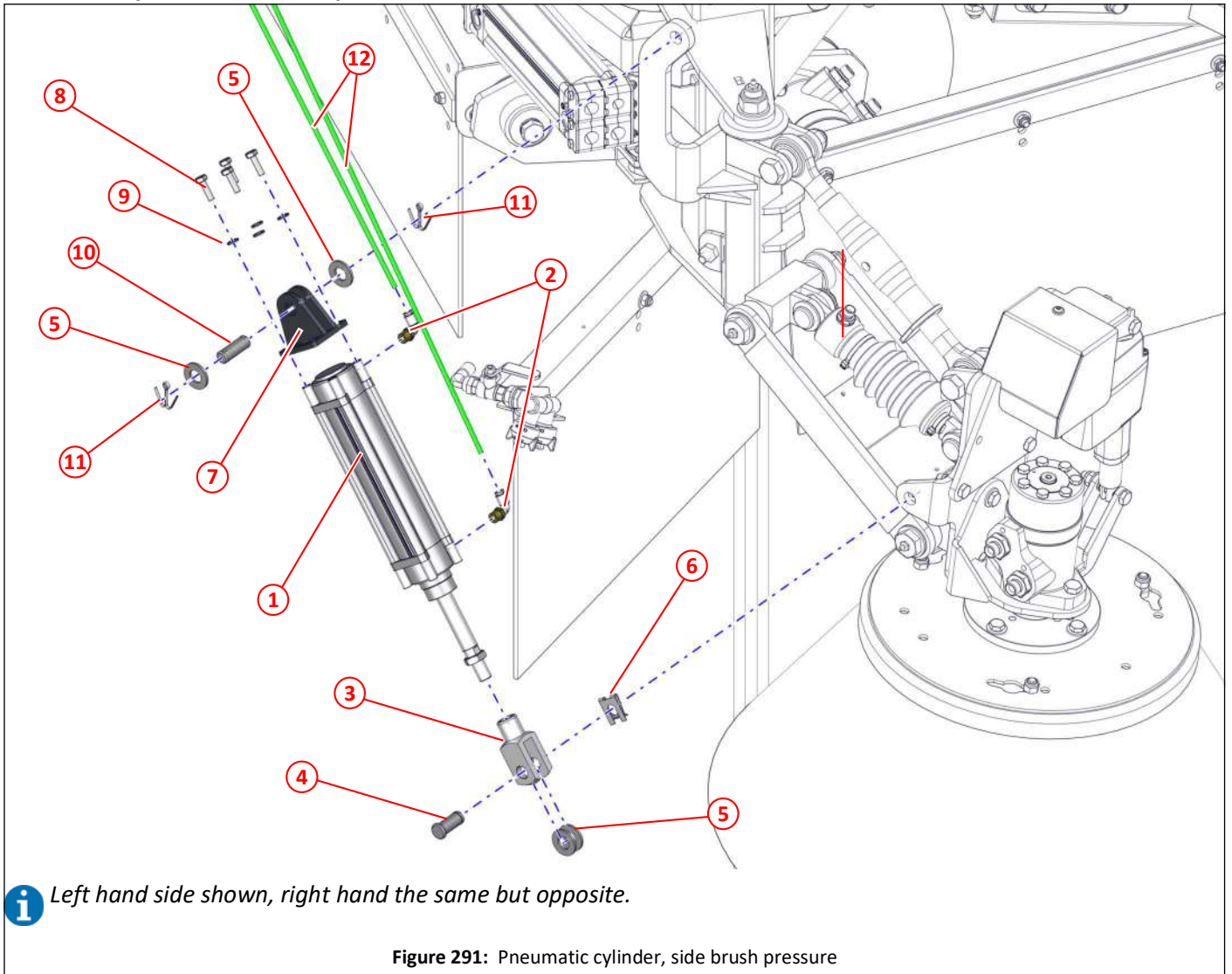

Item	Part No	Qty	Description
①	020298	1	Pneumatic cylinder $\phi 50 \times 160$
②	023203	2	Elbow, metal, swivel, $\frac{1}{4}$ " BSP x $\phi 6$ push in
③	020299	1	Clevis pneumatic M16 x 1.5
④	022673	1	Clevis pin turned
⑤	011135	4	Washer M16
⑥	022674	1	Clip retaining M16
⑦	023122	1	Ram end, pivot, $\phi 50$
⑧	011011	4	Setscrew HT M8 x 25
⑨	011093	4	Spring washer M8
⑩	023123	1	Pin $\phi 16 \times 46$
⑪	011122	2	Split pin, $\frac{3}{16}$ " x $1\frac{1}{2}$ "
⑫	024650	2	$\phi 6$ mm green air pipe, cut to length as required

Pneumatic cylinder, suction nozzle raise/lower

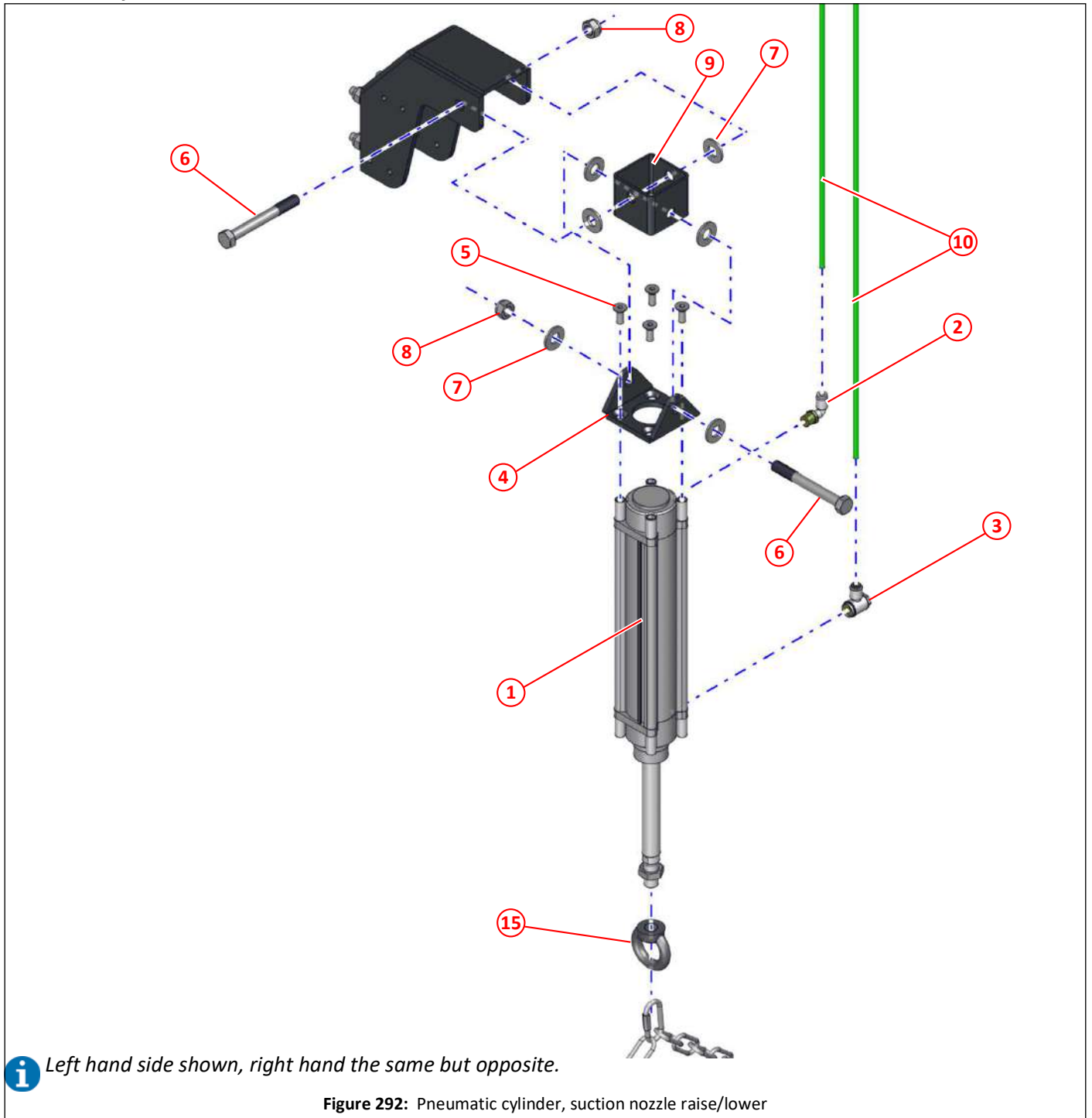

i Left hand side shown, right hand the same but opposite.

Figure 292: Pneumatic cylinder, suction nozzle raise/lower

Item	Part No	Qty	Description
①	030772	1	Pneumatic cylinder $\phi 50 \times 200$
②	023203	1	Elbow, metal, swivel, $\frac{1}{4}$ " BSP x $\phi 6$ push in
③	021158	1	Pneumatic flow regulator
④	030777	1	Cylinder pivot, suction nozzle lift
⑤	000003	4	Socket countersunk screw M8 x 20, plated
⑥	011057	2	Bolt M12 x 100
⑦	011096	6	Washer M12
⑧	011077	2	Nyloc nut T M12
⑨	030776	1	Cylinder pivot (gimbal), suction nozzle lift
⑩	024650	2	$\phi 6$ mm green air pipe, cut to length as required
⑮	032293	1	Ring nut M16 x 1.5

Pneumatic cylinder, auto blanking

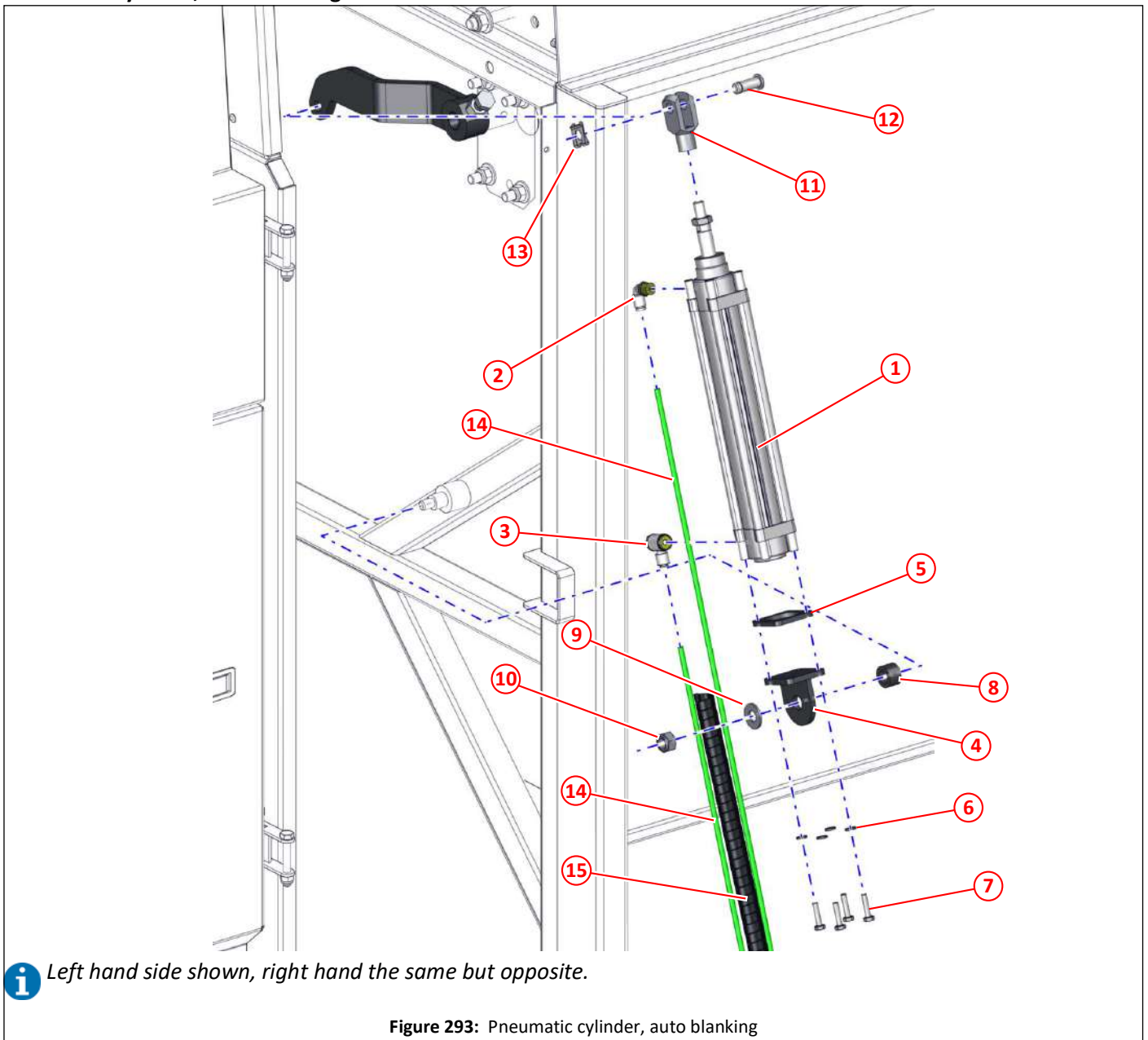

Figure 293: Pneumatic cylinder, auto blanking

Item	Part No	Qty	Description
①	021467	1	Pneumatic cylinder $\varnothing 40 \times 200$
②	023203	1	Elbow, metal, swivel, $\frac{1}{4}$ " BSP x $\varnothing 6$ push in
③	021158	1	Pneumatic flow regulator
④	014457	1	Cylinder pivot, auto blanking
⑤	045502	1	Spacer, auto blanking cylinder
⑥	011091	4	Spring washer M6
⑦	011087	4	Setscrew HT M6 x 25
⑧	011000	1	Rubber bush cut from, hose $\frac{5}{8}$ " fuel SAE100R6, cut to 15mm
⑨	000277	1	Washer M12, stainless steel
⑩	000275	1	Nyloc nut T M12
⑪	014469	1	Clevis, pneumatic M12.
⑫	023270	1	Clevis pin $\varnothing 12$
⑬	023269	1	Safety fastener $\varnothing 12$
⑭	024650	2	$\varnothing 6$ mm green air pipe, cut to length as required
⑮	004210	1	Flex cable conduit, split, $\varnothing 21$

Pneumatic cylinder, hopper safety prop, kicker

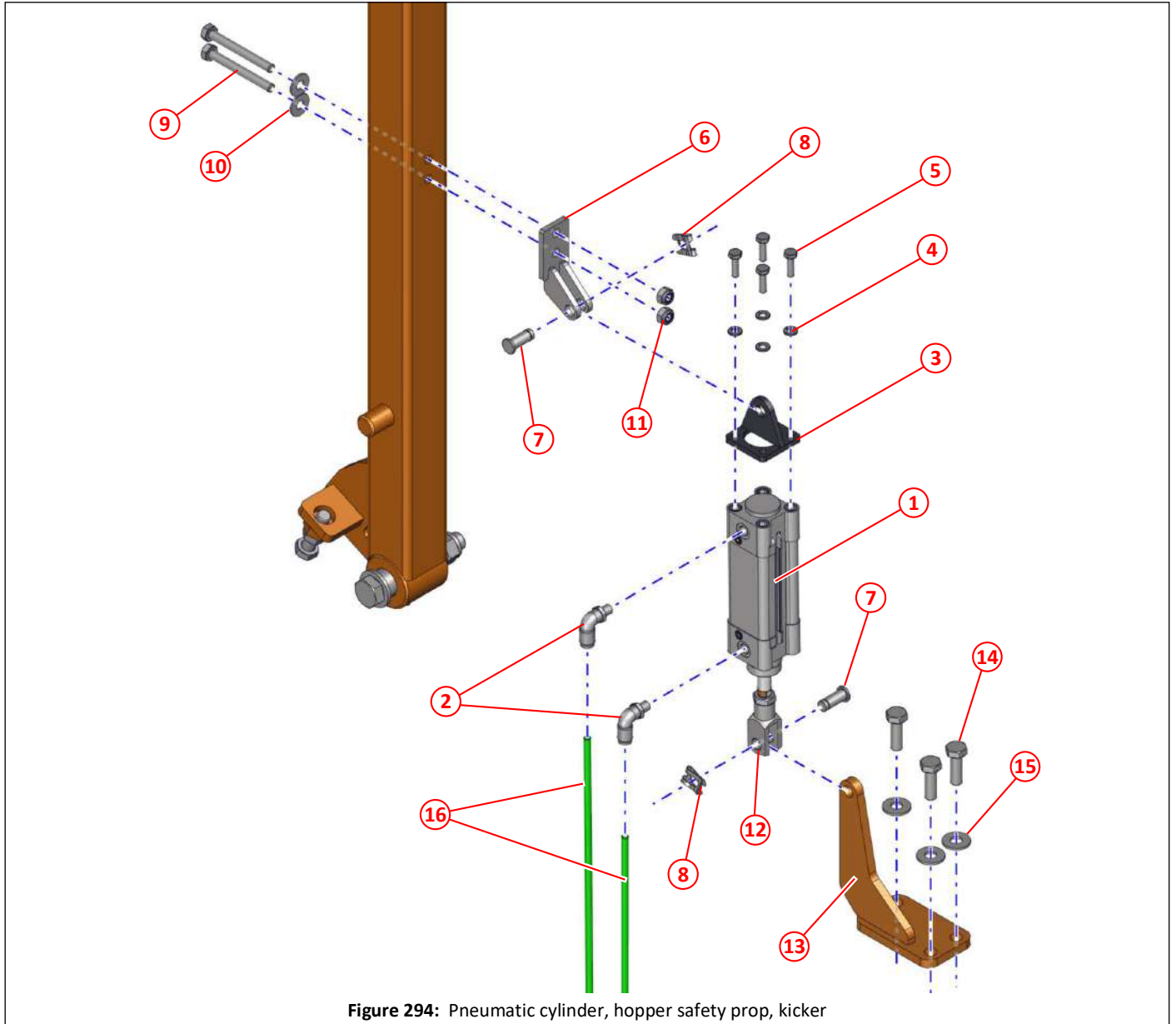

Figure 294: Pneumatic cylinder, hopper safety prop, kicker

Item	Part No	Qty	Description	
①	040456	1	Pneumatic cylinder $\phi 32 \times 50$, sprung return	383
②	023203	2	Elbow, metal, swivel, $\frac{1}{4}$ " BSP x $\phi 6$ push in	
③	043174	1	Prop kicker cylinder mount	
④	000255	4	Spring washer M6, stainless steel	
⑤	000252	4	Setscrew M6 x 20, stainless steel	
⑥	043390	1	Prop kicker mount	
⑦	026163	2	Clevis pin M10	
⑧	026164	2	Clip retaining M10	
⑨	011018	2	Bolt HT M8 x 70	
⑩	011092	2	Washer M8	
⑪	011073	2	M8 T NYLOC NUT	
⑫	020291	1	Clevis pneumatic M10 x 1.25	
⑬	047357	1	Prop kicker floor mount	
⑭	011032	3	Setscrew HT M10 x 30	
⑮	011094	3	Washer M10	
⑯	024650	2	$\phi 6$ mm green air pipe, cut to length as required	

Electrical

<i>Description</i>	<i>Page</i>
Cab components	338
Main control panel	338
Auxiliary controller (door pod)	339
Hopper controller remote	340
Display screen, operator, programmed	340
CR2012 cabinet module, node	340
Beacon switch	341
Sounder, main control panel	341
Camera monitor	341
Camera splitter	342
Fuses and relays, cab	342
Pneumatic and Node cabinet	343
Nodes	344
Relays	344
Power connection link	344
Power post	345
Switch, gantry work light	345
Cabinet fuse holder arrangement	346
Cabinet fuses	347
Battery junction box	348
Resistors for hydraulic coils, 12V	349
Light, lamps and cameras	350
LED work light	350
LED marker rear light	350
Beacon	350
LED warning beacon	351
Cameras	351
Wiring looms and cables	352
Switches	352
Sensors	353
Fuses	353
Relays	353

Cab components
Main control panel

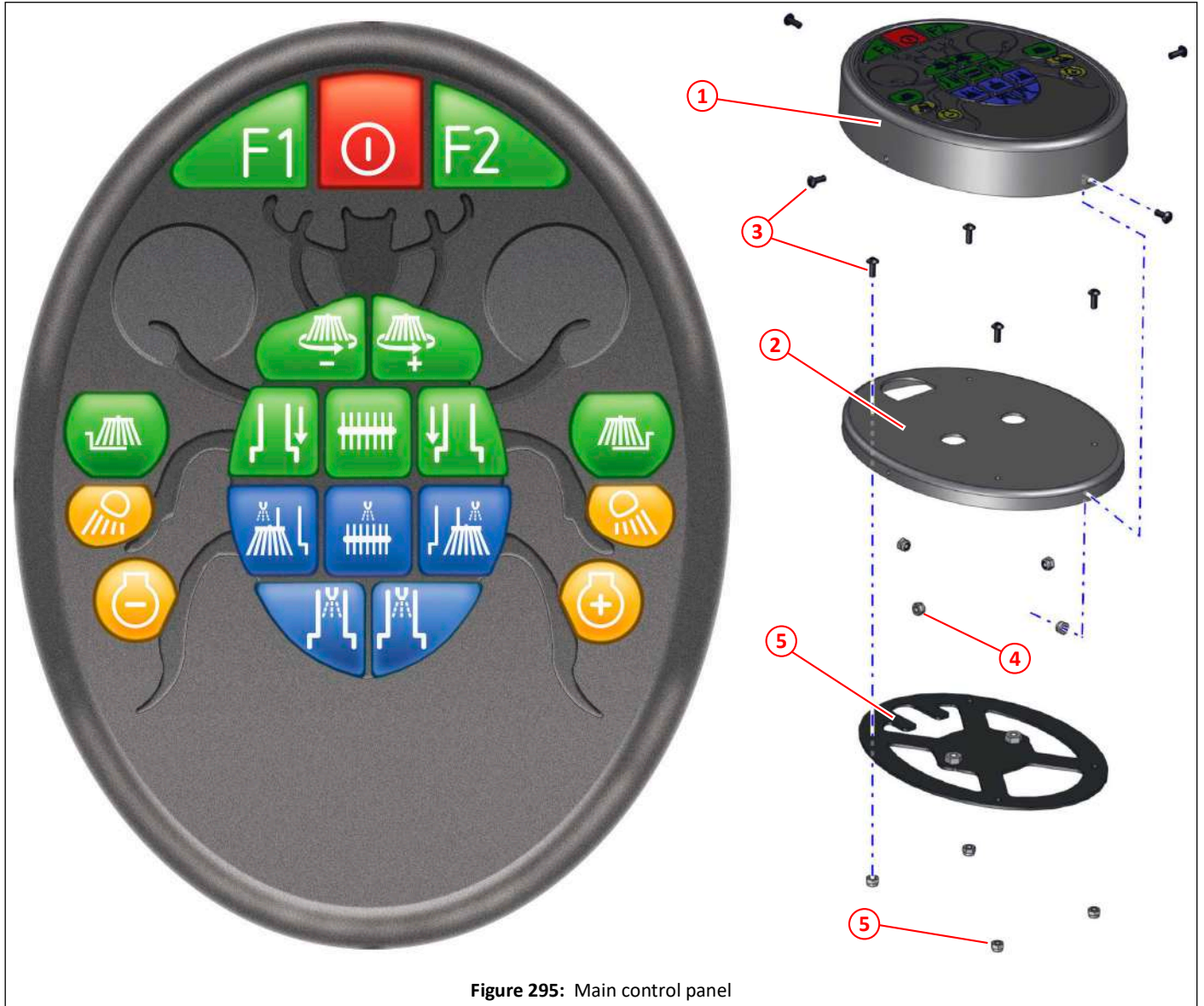

Figure 295: Main control panel

Item	Part No	Qty	Description	
①	037602	1	Main control panel, keypad and fascia	
②	037053	1	Backplate, main control panel	
③	000304	8	Socket button head M4 x 10, black	
④	000134	8	Nyloc nut M4	
⑤	037055	1	Spider plate, main control panel	
⑥	036912	1	Loom, main control panel, not illustrated	352
⑦	036914	1	Loom, power/CAN, main control panel, not illustrated	352

Auxiliary controller (door pod)



Figure 296: Auxiliary controller (door pod)

Item	Part No	Qty	Description	
①	037608	1	Auxiliary controller (door pod), fascia and keypad	
②	037057	1	Support plate, auxiliary controller (door pod)V3	
③	037058	1	Backplate, auxiliary controller (door pod)	
④	036873	1	Ergo joystick	
⑤	046259	1	Grommet, semi blind, ø15.9	
⑥	000380	4	Socket button head screw M4 x 10, black	
⑦	037064	1	Door pod lock washer	
⑧	011031	1	Setscrew HT M10 x 25	
⑨	039545	1	Label, ergo joystick	
⑩	036913	1	Loom, auxiliary control panel (door pod), not illustrated	352
⑪	036915	1	Loom, power/CAN, auxiliary control panel (door pod), not illustrated	352

Hopper controller remote



Figure 297: Hopper controller remote

Item	Part No	Qty	Description	
①	043688	1	Hopper controller (PXL)	
②	043691	1	Holster, hopper controller (PXL)	
③	044294	1	Hopper controller complete with holster, includes items ① and ②	
④	037047	1	Loom, hopper controller	352

Display screen, operator, programmed

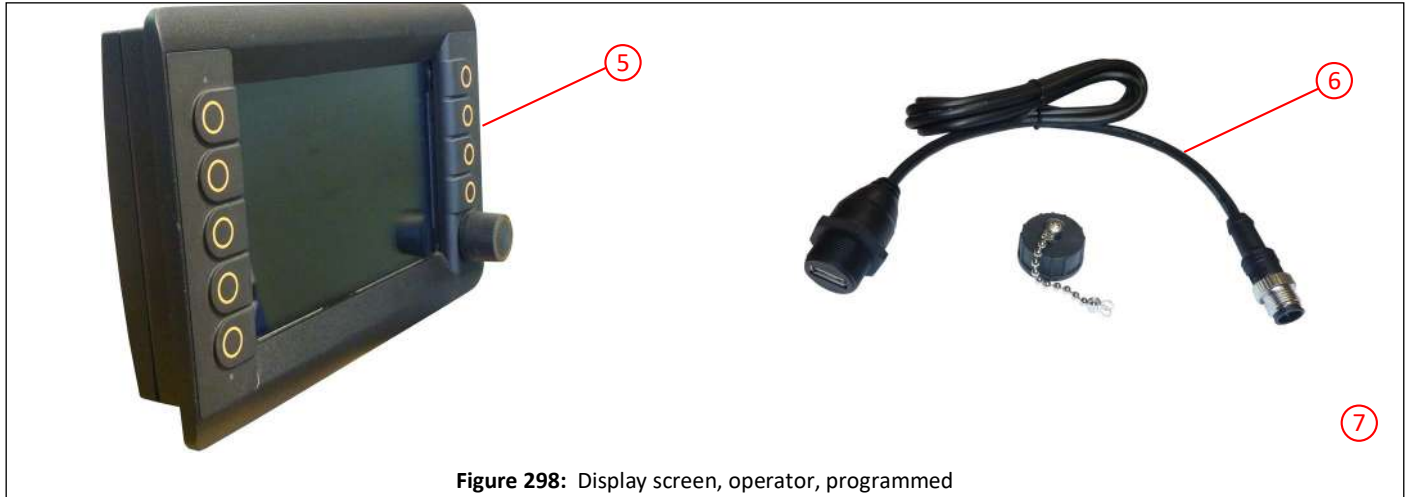

Figure 298: Display screen, operator, programmed

Item	Part No	Qty	Description	
⑤	051757	1	Display screen, operator, CR1084, programmed	
⑥	039672	1	Cable, M12 to USB	352
⑦	040349	1	Loom, display screen	352

CR2012 cabinet module, node

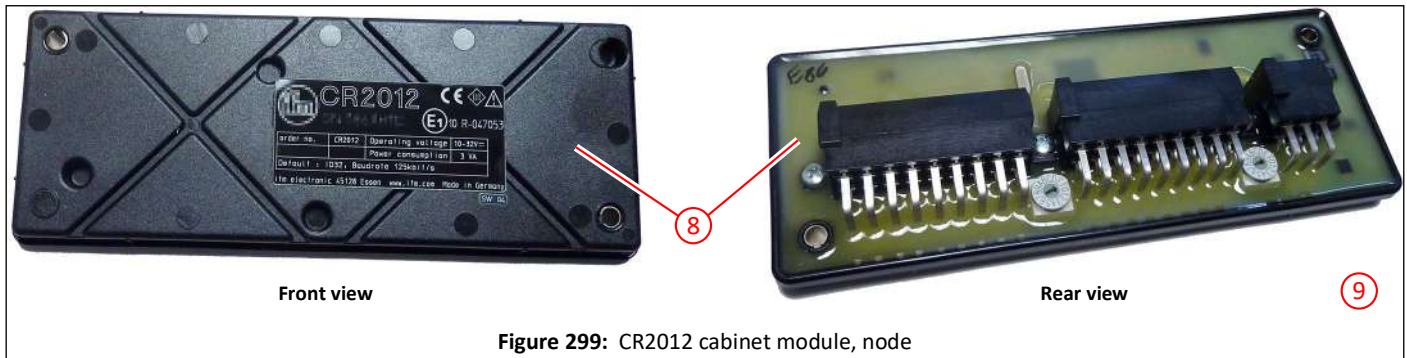

Figure 299: CR2012 cabinet module, node

Item	Part No	Qty	Description	
⑧	036799	1	CR2012 cabinet module, node, behind dash	
⑨	038013	1	Loom, cab	

Beacon switch



Figure 300: Beacon switch

Item	Part No	Qty	Description
①	042049 *	1	Beacon switch, DAF
②	038543 *	1	Beacon switch, Renault
③	038013	1	Loom, cab

*. Switches for other chassis manufacturers please contact Scarab Parts Department.

Sounder, main control panel

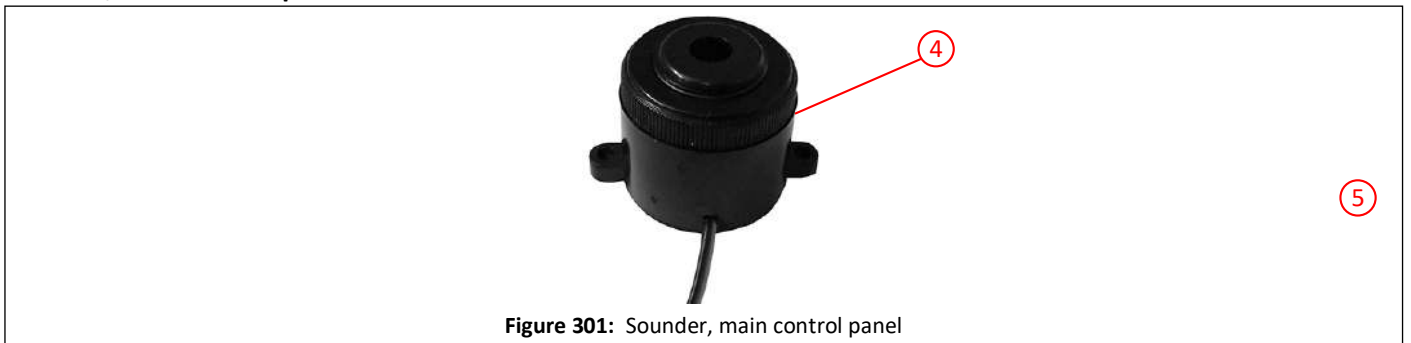

Figure 301: Sounder, main control panel

Item	Part No	Qty	Description
③	037048	1	Sounder
⑤	036912	1	Loom, main control panel

Camera monitor



Figure 302: Camera monitor

Item	Part No	Qty	Description
⑥	040717 *	1	Camera monitor

420,425

*. Other camera monitors can be supplied, please contact Scarab Parts Department for more information.

Camera splitter

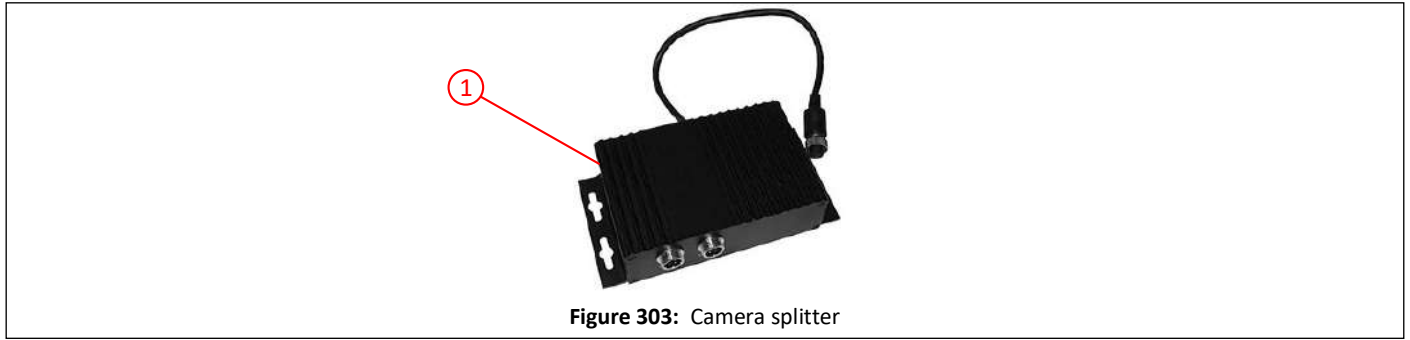

Figure 303: Camera splitter

Item	Part No	Qty	Description
①	041534	1	Camera splitter

Fuses and relays, cab

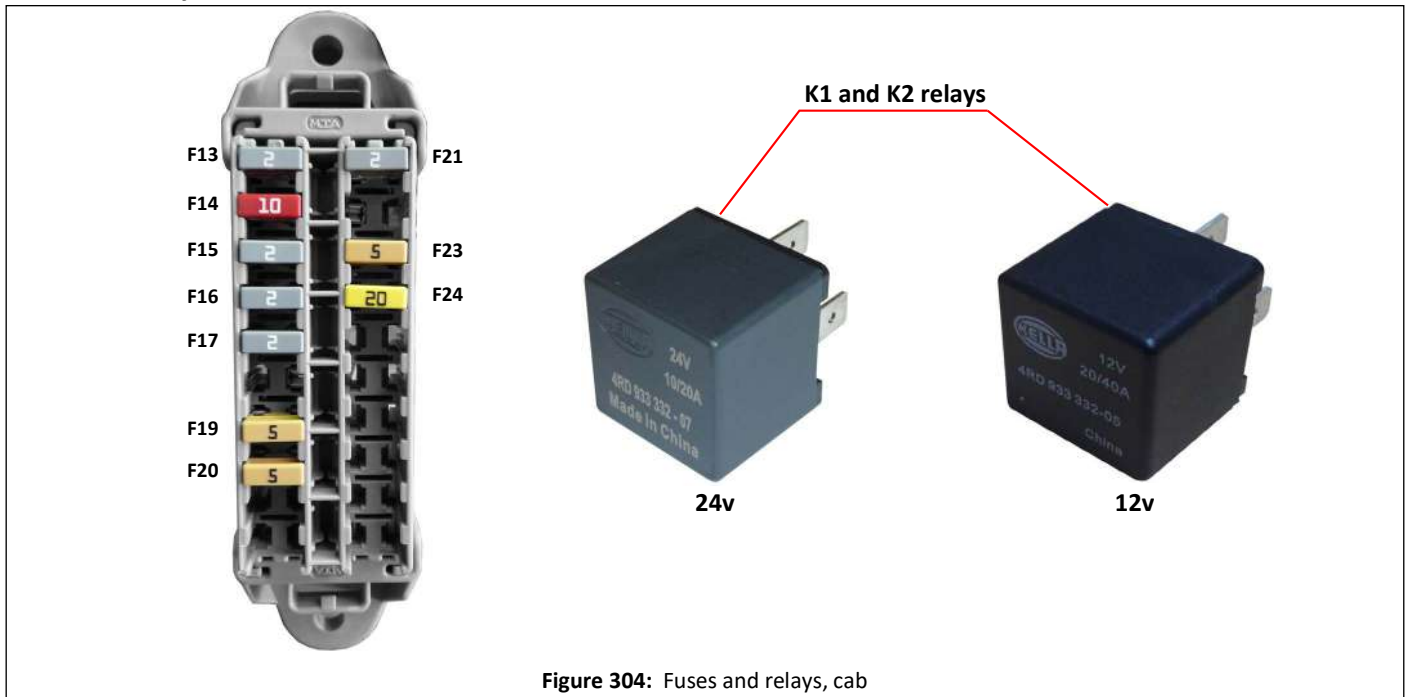

Figure 304: Fuses and relays, cab

Item	Part No	Qty	Description	
F13	004495	1	Fuse, mini blade, 2 Amp, Vehicle ignition	
F14	004393	1	Fuse, mini blade, 10 Amp, Scarab, Ignition+	
F15	004495	1	Fuse, mini blade, 2 Amp, Node 2, LCD Monitor, Ignition+	
F16	004495	1	Fuse, mini blade, 2 Amp, Node 0, Auxiliary Control Panel, Ignition+	
F17	004495	1	Fuse, mini blade, 2 Amp, Node 1, Main Control Panel, Ignition+	
F19	004391	1	Fuse, mini blade, 5 Amp, Body Builder Plug, Ignition+	
F20	004391	1	Fuse, mini blade, 5 Amp, Hopper Remote Control Unit, Ignition+	
F21	004495	1	Fuse, mini blade, 2 Amp, Node 2, LCD Monitor, Battery+	
F23	004391	1	Fuse, mini blade, 5 Amp, Body Builder Plug, Battery+	
F24	004395	1	Fuse, mini blade, 20 Amp, Beacon(s)	
K1	011768	1	Relay, 10/20 Amp, Beacon(s), 12v	353
K1	014718	1	Relay, 10/20 Amp, Beacon(s), 24v	353
K2	011768	1	Relay, 10/20 Amp, Ignition, 12v	353
K2	014718	1	Relay, 10/20 Amp, Ignition, 24v	353

i The above items are located on the cab loom and will be behind the dash on the vehicle.

Pneumatic and Node cabinet

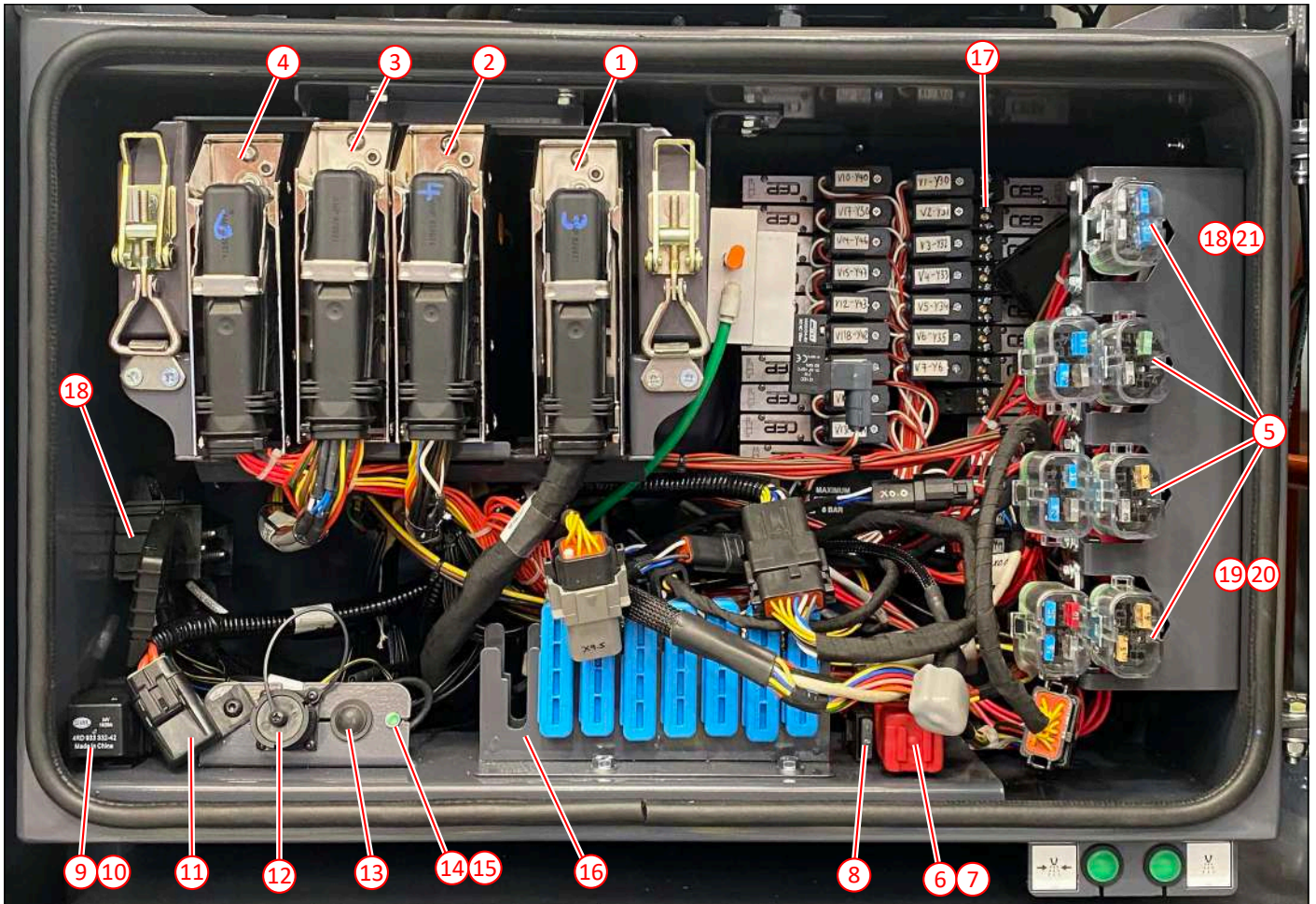

Figure 305: Pneumatic and Node cabinet

Item	Part No	Qty	Description	
①	051756	1	Node 3, CR0505, programmed	344
②	051758	1	Node 4, CR0020, programmed	344
③	051758	1	Node 5, CR0020, programmed	344
④	051758	1	Node 6, CR0020, programmed	344
⑤			Fuse boxes, Node 4, Node 5, Node 6, part of the node looms	346,347
⑥	045511	1	Timer relay, engine work light, K7, holder part of engine work light loom, 12V	344
⑦	014718	1	Timer relay, engine work light, K7, holder part of engine work light loom, 24V	344
⑧	004485	1	Fuse, blade, 2 Amp, engine work light, F33, holder part of engine work light loom	
⑨	011768	1	Relay, fuel pump, K6, holder part of engine loom, 12v	344
⑩	014718	1	Relay, fuel pump, K6, holder part of engine loom, 24v	344
⑪	014292	1	Fuse, blade, 30 Amp, engine ECU, F29, holder part of engine loom	
⑫			Engine diagnostic plug, part of Node 3 loom	
⑬		1	Engine diagnostic switch, part of Node 3 loom	
⑭	004565	1	Engine diagnostic lamp, 12V	
⑮	004564	1	Engine diagnostic lamp, 24V	
⑯	037994	1	Splice saver rack	
⑰			Pneumatics board	314,316
⑱	004616	2	Power connection link, one either side of cabinet	344
⑲	036843	1	Power post, M6, red, behind fuse boxes	345
⑳	004489	1	Rubber boot, red, for power post	345
㉑	038223	1	Switch gantry work light, green, on side of cabinet, behind fuse boxes	345

Nodes

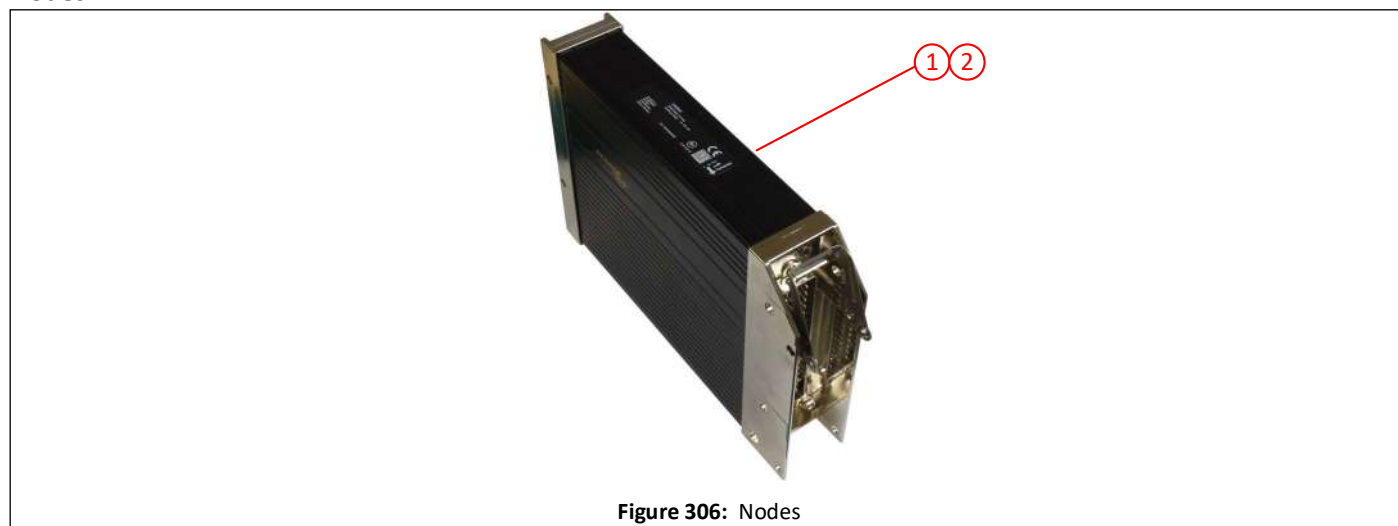

Figure 306: Nodes

Item	Part No	Qty	Description
①	051756	1	Node 3, CR0032, programmed
②	042336	1	Node 4, Node 5 or Node 6, CR0032, programmed

Relays



Figure 307: Relays

Item	Part No	Qty	Description
③	014718	1	Relay, fuel pump, K6, 24v
④	011768	1	Relay, fuel pump, K6, 12v
⑤	043720	1	Timer relay, gantry work light, K7, 24v
⑥	044511	1	Timer relay, gantry work light, K7, 12v

Power connection link

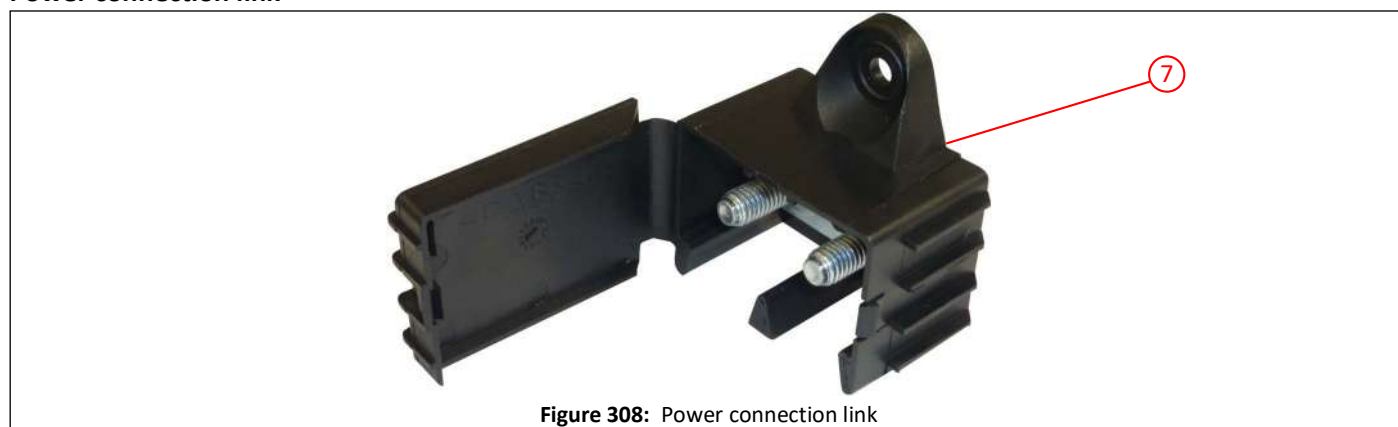

Figure 308: Power connection link

Item	Part No	Qty	Description
⑦	036844	1	Power connection link, supplied with Nyloc nuts

Power post

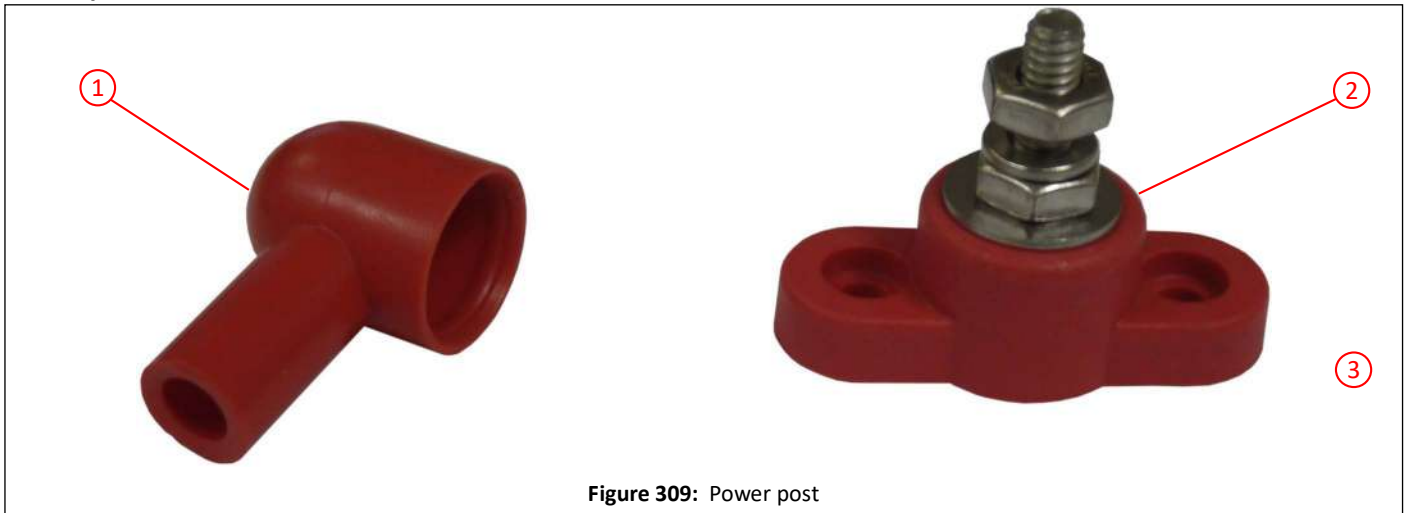

Figure 309: Power post

Item	Part No	Qty	Description
①	004489	1	Rubber boot, power post, red
②	036843	1	Power post, red
③	000429	1	Nyloc nut, 1/4" UNC, plated, to be used on power post instead of top half nut

Switch, gantry work light



Figure 310: Switch, gantry work light

Item	Part No	Qty	Description
④	038223	1	Switch, gantry work light, green
⑤	043719	1	Loom, gantry work light

Cabinet fuse holder arrangement

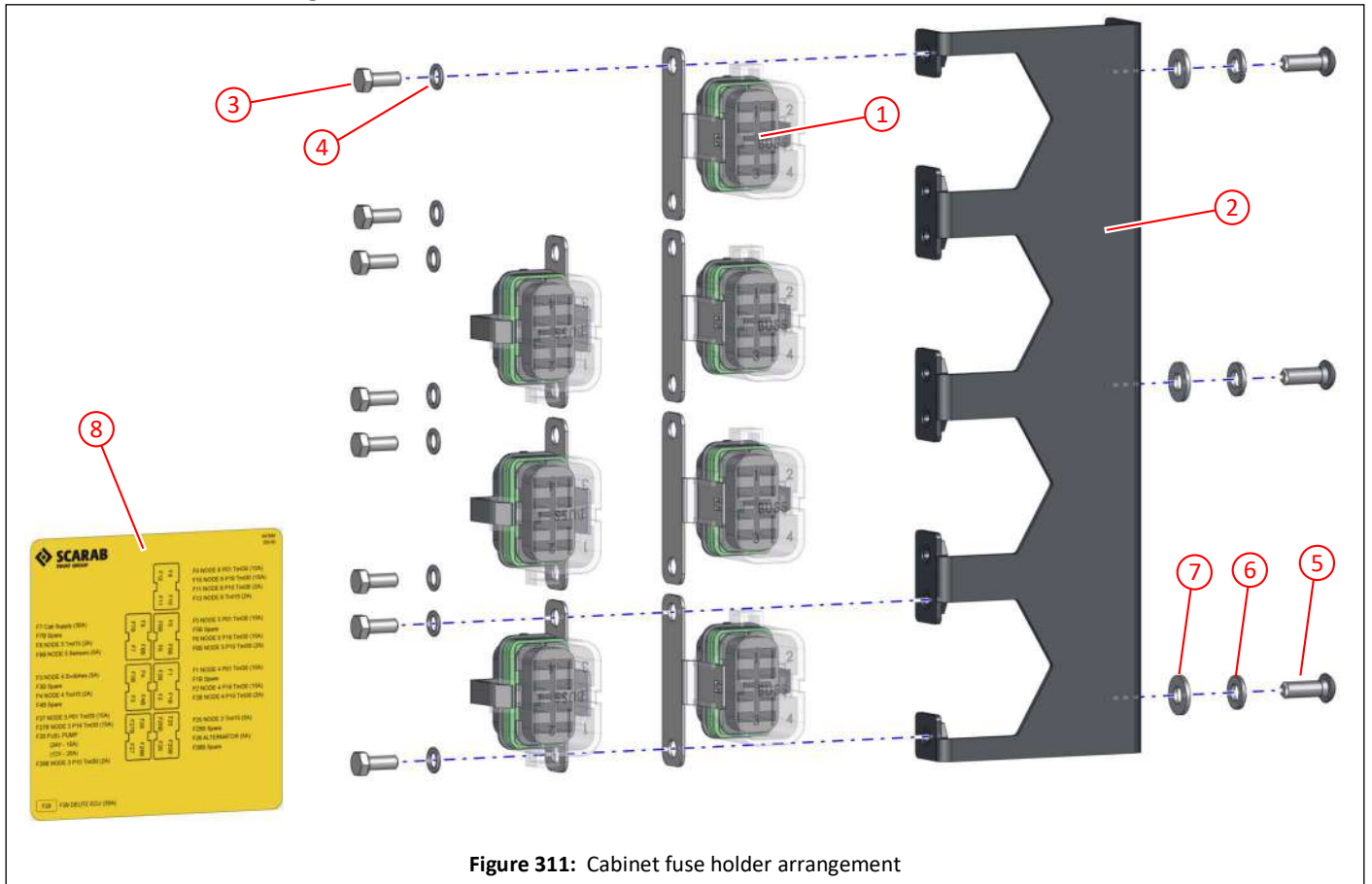
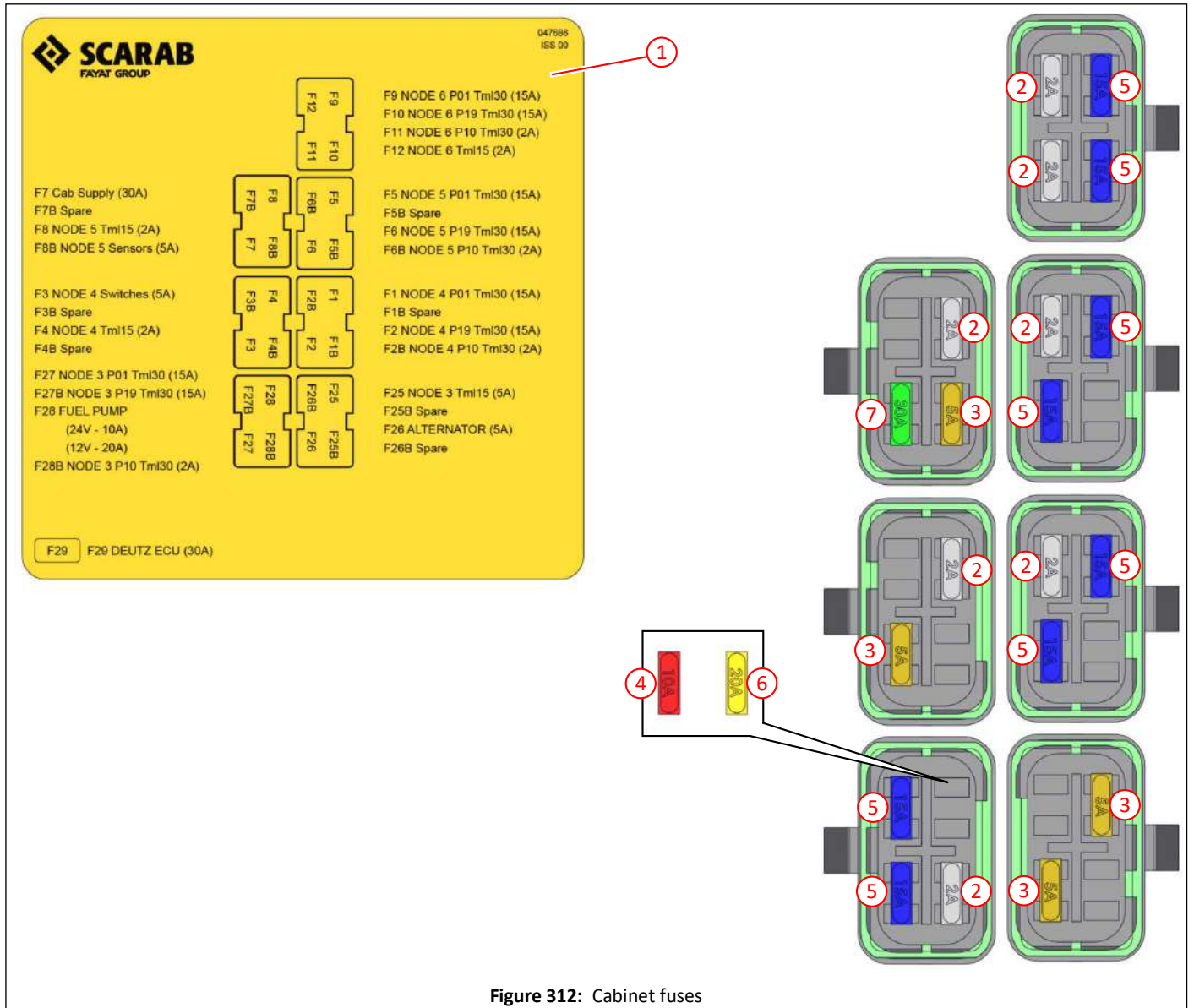

Figure 311: Cabinet fuse holder arrangement

Item	Part No	Qty	Description
①	004626	7	Fuse holder assembly, 4 way
②	047829	1	Cabinet fuse mount
③	000097	8	Bolt M5 x 12
④	000411	8	Spring washer M5
⑤	000373	3	Socket dome head screw M6 x 16, stainless steel
⑥	000255	3	Spring washer M6, stainless steel
⑦	000254	3	Washer M6, stainless steel
⑧	047686	1	Label - V3.2 cabinet fuses, Maven 65, on inside of cabinet door

Cabinet fuses



Item	Part No	Qty	Description
①	047686	1	Label - V3.2 cabinet fuses, Maven 65, on inside of cabinet door
②	004495	7	Fuse, mini blade, 2 Amp
③	004391	4	Fuse, mini blade, 5 Amp
④	004393	1	Fuse, mini blade, 10 Amp
⑤	004394	8	Fuse, mini blade, 15 Amp
⑥	004395	1	Fuse, mini blade, 20 Amp
⑦	004397	1	Fuse, mini blade, 30 Amp

i Please note the correct fuse to use for 12V and 24V systems in F28 FUEL PUMP.

Battery junction box

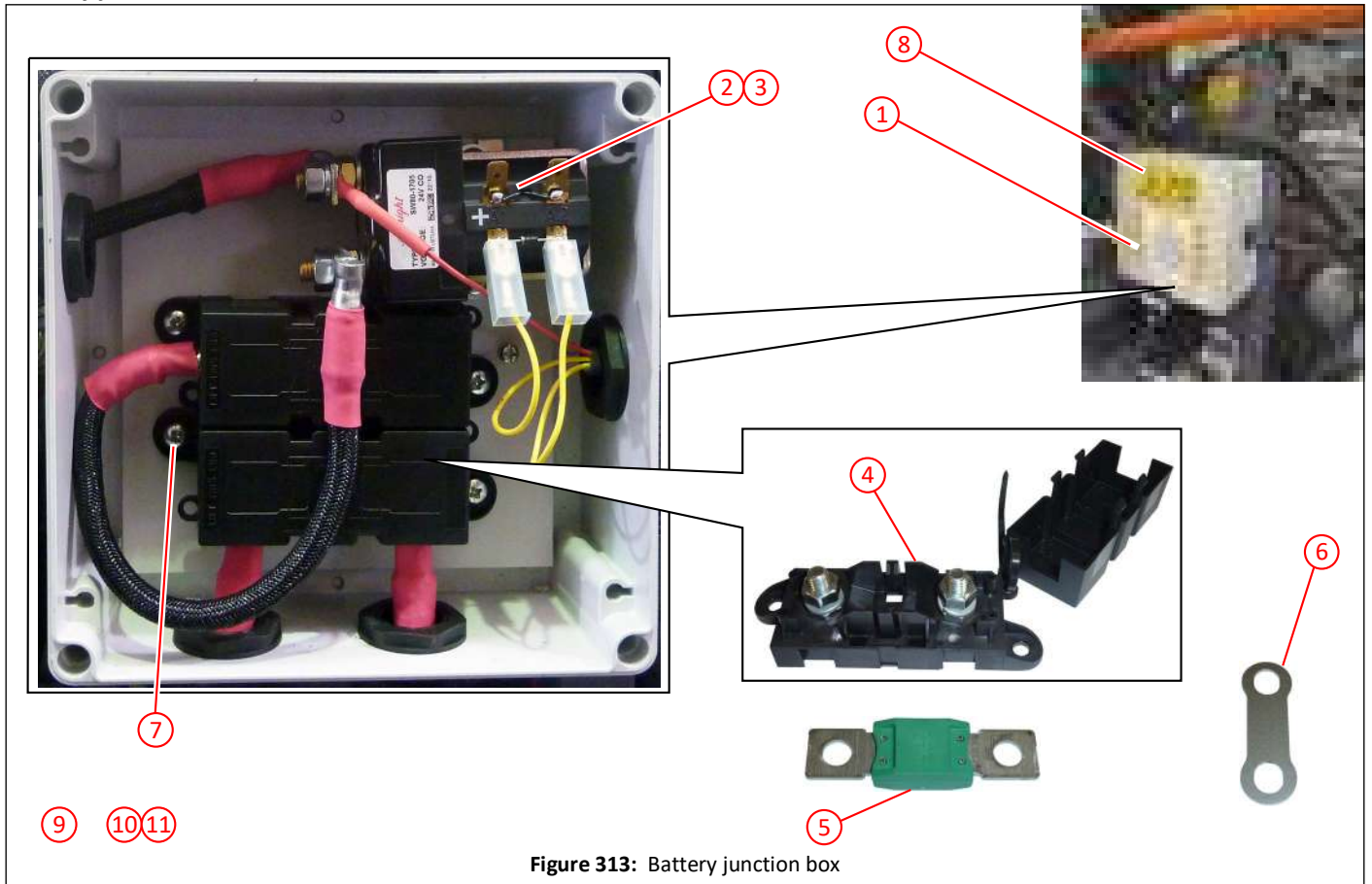

Figure 313: Battery junction box

Item	Part No	Qty	Description	
①	043350	1	Battery junction box, includes the lid, lid fixings and the 4 battery cables	
②	038571	1	Relay, glow plug heat, K5, 12v	353
③	034207	1	Relay, glow plug heat, K5, 24v	353
④	004506	2	Mega fuse holder	
⑤	004422	2	Mega fuse 125 Amp, F30 and F31	353
⑥	043381	1	BUS bar, mega fuse, connects the two mega fuses on the right hand side	
⑦	011115	6	Self tapping screw, No.10 x 1/2" POZIDRIV, for fitting mega fuse holder and relay	
⑧	043268	1	Label - Warning electrical	
⑨	046885	1	Loom, DEUTZ STG V engine	
⑩	044537	1	Junction box assembly, includes items ①-⑧, 12v (not item ③)	
⑪	043380	1	Junction box assembly, includes items ①-⑧, 24v (not item ②)	

Resistors for hydraulic coils, 12V

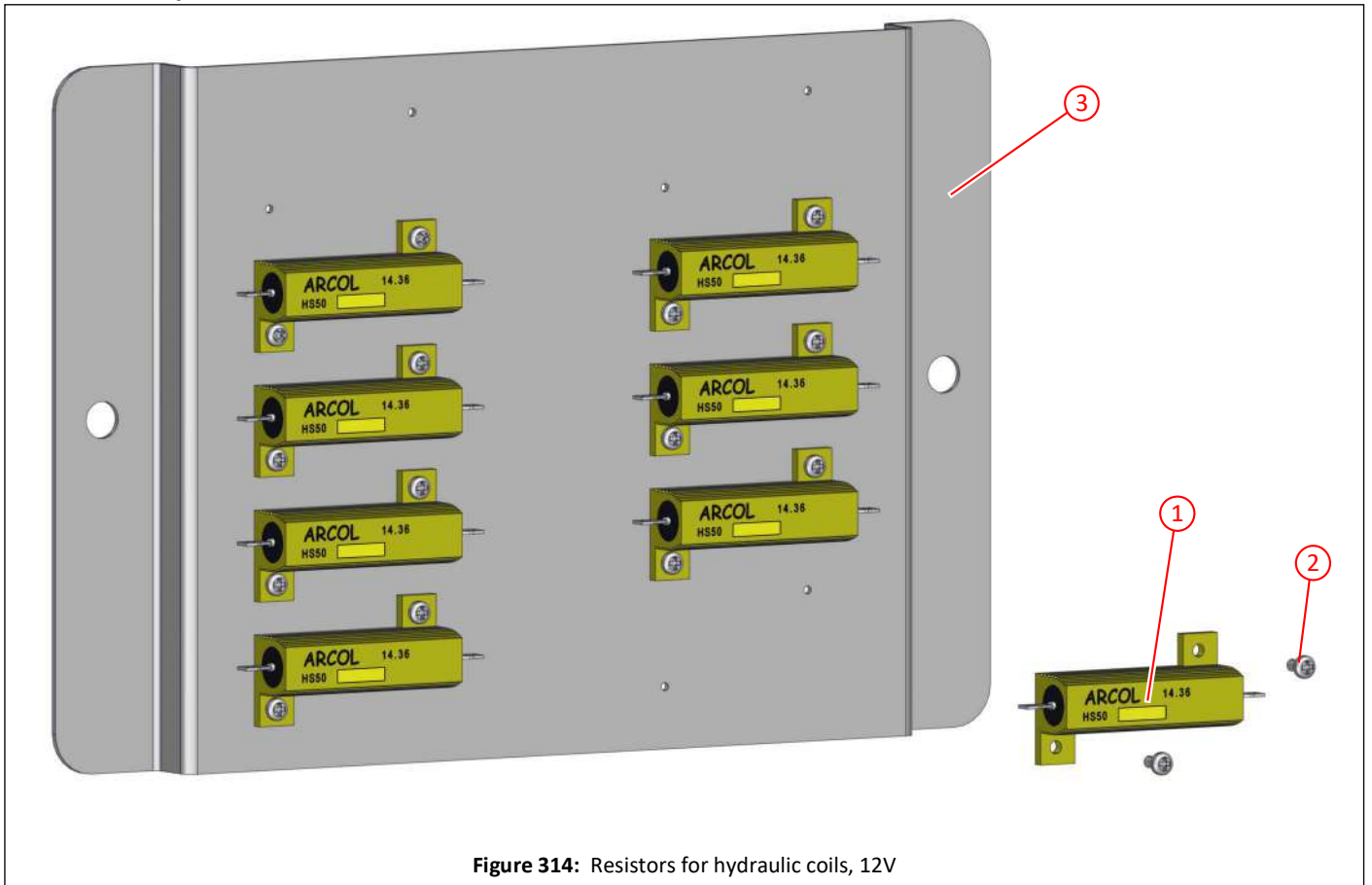

Figure 314: Resistors for hydraulic coils, 12V

Item	Part No	Qty	Description
①	048491	8	1 OHM resistor loom
②	000548	16	Pan head, POZIDRIV, self tapping screw No.4 x 6mm, zinc
③	048490	1	Plate, 1 OHM resistors

i Only used on 12V systems. This is located inside the hydraulic cabinet, behind the main valve block.

Light, lamps and cameras

LED work light

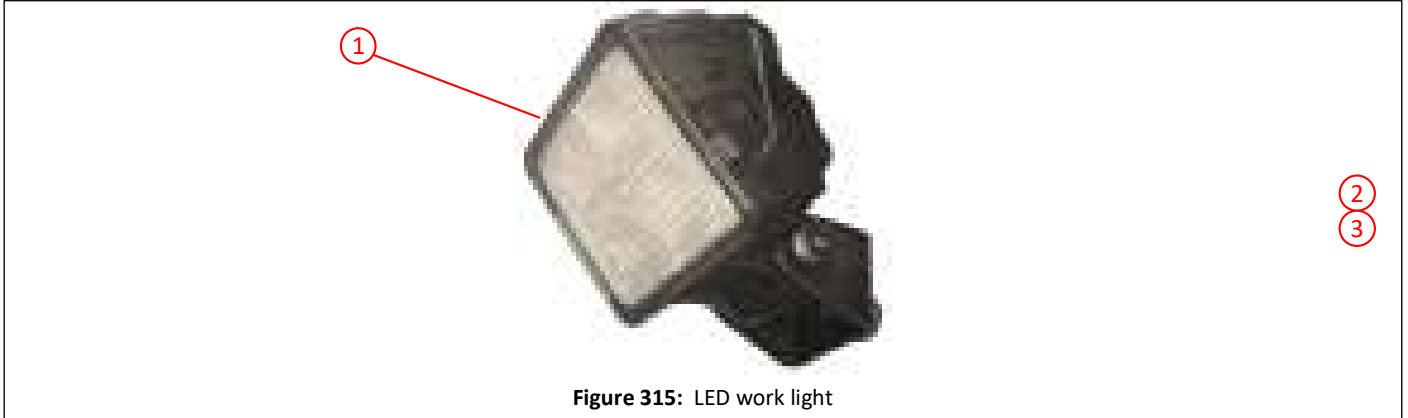

Item	Part No	Qty	Description	
①	047757	1	LED work light, 12/24v	
②	047385	1	Loom, Node 5	352
③	043719	1	Loom, gantry work light	352

LED marker rear light

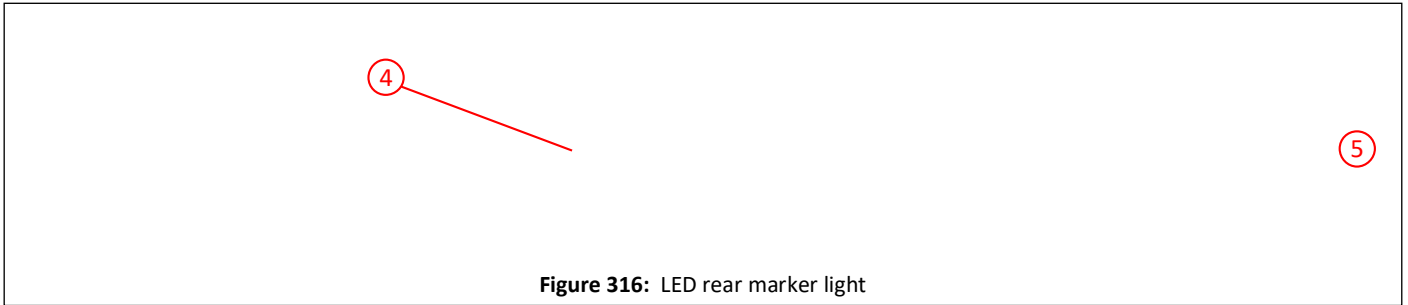

Item	Part No	Qty	Description	
④	030773	1	LED rear marker light	
⑤	036911	1	Loom, hopper	352

Beacon

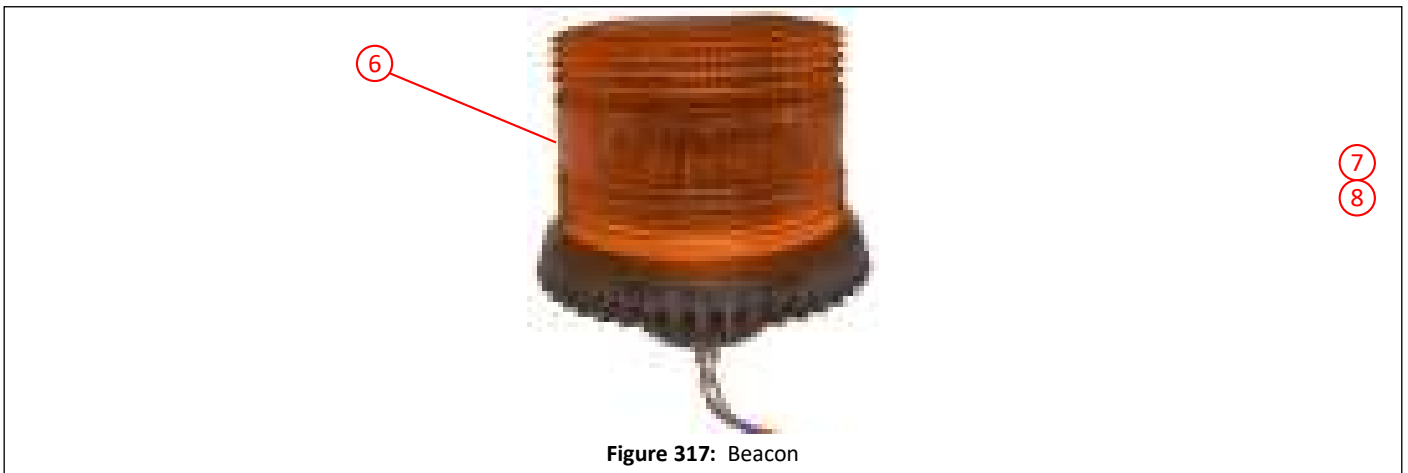

Item	Part No	Qty	Description	
⑥	046659	1	LED beacon, single bolt fixing, 10-30V	
⑦	036911	1	Loom, hopper	352
⑧	040727	1	Loom, twin beacons	352

LED warning beacon



Figure 318: LED warning beacon

Item	Part No	Qty	Description	
①	047979	1	BST LED warning light assembly	
②	047782	1	Loom, Main, LED BST warning light	352
③	047783	1	Loom, 1750mm, LED BST warning light	352
④	047784	1	Loom, 2750mm, LED BST warning light	352
⑤	047785	1	Loom, 4750mm, LED BST warning light	352
⑥	047786	1	Loom, Y cable, LED BST warning light	352
⑦	004049	1	Cable, 9/0.30 twin core round, cut to length required	352
⑧	004161	1	Conduit (split), flexible, ø15.7, cut to length required	

Cameras



Figure 319: Cameras

Item	Part No	Qty	Description	
⑨	040354	1	Camera	
⑩	043897	1	Camera, eyeball	
⑪	040353	1	Power supply and cable, camera	
⑫	000484	2	UM & L socket terminal caps	
⑬	040355	1	Cable, camera, 15m	
⑭	040719	1	Cable, camera, 5m	
⑮	040718	1	Cable, camera, 2,5m	

Wiring looms and cables

Part No	Description	
036842	M12 plug/cable and valve plug type B	
036911	Loom, hopper	
036912	Loom, main controller keypad	
036913	Loom, auxiliary controller (door pod) keypad	
036914	Loom, main controller keypad, power/CAN	
036915	Loom auxiliary controller (door pod), power/CAN	
037047	Loom, hopper controller, cab	
037331	Loom, brush up/down pressure	
038013	Loom, cab	
039672	Cable, M12 to USB	
040349	Loom, display screen	
040727	Loom, twin beacon	
046885	Loom, DEUTZ STG V engine	
047383	Loom, Node 3 - Note: Supplied with 10 Amp fuse in F28 for 24v . 20 Amp fuse required if 12v .	343
047384	Loom, Node 4	343
043347	Loom, hydraulic block	
047385	Loom, Node 5	343
047386	Loom, Node 6	343
043435	Cable, battery-starter, positive	
043719	Loom, gantry work light	343
047782	Loom, Main, LED BST warning light	351
047783	Loom, 1750mm, LED BST warning light	351
047784	Loom, 2750mm, LED BST warning light	351
047785	Loom, 4750mm, LED BST warning light	351
047786	Loom, Y cable, LED BST warning light	351
004049	Cable, 9/0.30 twin core round	351
038536	Cable, battery, positive, red, 24v	
043436	Cable, engine/CANbus earth, 24v	
044530	Cable, engine/CANbus earth, 12v	
044531	Cable, battery, positive, red, 12v	
046708	Loom, DEUTZ power supply, 12v only	

Switches

Part No	Description	
038223	Switch, gantry work light, green	343
038543 *	Beacon switch, Renault	
042049 *	Beacon switch, DAF	

*. Switches for other chassis manufacturers please contact Scarab Parts Department.

Sensors

Part No	Description	
032627	Proximity sensor, hopper raise	
041698	Low level sensor, engine coolant expansion tank	
036871	Float switch, with amp plug, water tank	217
035466	Fuel sender unit 450mm	
045113	Water in fuel (WIF) sensor, fuel filter, with cable	
043797	Lubrication oil pressure sensor	
043814	Coolant temperature sender	
047885	Pressure sensor, 0 - 250mBar, $\frac{1}{4}$ " BSP male	

i For location of the engine sensors see the Engine section.

Fuses

Part No	Description	
004495	Fuse, mini, 2 Amp	
004569	Fuse, mini, 3 Amp	
004391	Fuse, mini, 5 Amp	
004392	Fuse, mini, 7.5 Amp	
004393	Fuse, mini, 10 Amp	
004394	Fuse, mini, 15 Amp	
004395	Fuse, mini, 20 Amp	
004396	Fuse, mini, 25 Amp	
004397	Fuse, mini, 30 Amp	
004485	Fuse, blade, 2 Amp	
014284	Fuse, blade, 3 Amp	
014285	Fuse, blade, 4 Amp	
014286	Fuse, blade, 5 Amp	
014287	Fuse, blade, 7.5 Amp	
014288	Fuse, blade, 10 Amp	
014289	Fuse, blade, 15 Amp	
014290	Fuse, blade, 20 Amp	
014291	Fuse, blade, 25 Amp	
014292	Fuse, blade, 30 Amp	
004422	Mega fuse 125 Amp	348

Relays

Part No	Description	
011768	Relay, K1, K2, K6, 12v	
014718	Relay, K1, K2, K6, 24v	
038571	Relay, glow plug heat, F30, 12v	
034207	Relay, glow plug heat, F30, 24v	
044511	Timer relay, gantry work light, K7, 12v	
043720	Timer relay, gantry work light, K7, 24v	

Engine frame and subframe

<i>Description</i>	<i>Page</i>
Engine Frame	356
Roof panel	356
Hopper extension wing, left hand	357
Hopper extension wing, right hand	358
Front door, left hand	359
Front door, right hand	360
End panels	361
Hydraulic oil tank mounting	362
Node-pneumatics cabinet mounting	363
Fuel tank mounting	364
Fuel tank	365
Combined intercooler/radiator/hydraulic oil cooler blanking	366
Combined intercooler/radiator/hydraulic oil cooler mounting	367
Safety bar	368
Battery junction box and oil filter mounting	369
Fuel filters and fuel pump mounting	370
Hopper raise proximity sensor	371
Exhaust stack mounting	372
Air intake stack mounting	373
Coolant expansion tank mounting	374
Remote mounted flow control valve mounting	375
Rear engine mount	376
Front engine mount	377
ECU cover	378
Hydraulic cabinet	379
Main and options valve blocks mounting	380
Lifting eyes	381
Engine frame and ancillary parts	382
Subframe	383
Engine frame and subframe general arrangement	383
Engine frame to subframe mounting	384
Subframe to chassis mounting general arrangement	385
Subframe to chassis mount, position 1	386
Subframe to chassis mount, position 2	387
Subframe to chassis mount, position 3 and 4	388
Subframe to chassis lateral support	389
Folding ladder and grab handle mounting	390
Folding ladder and grab handle	391
Hopper lift ram subframe mounting	392
Hopper safety prop subframe mounting	393
Floor plate	394
Nozzle lift cylinder mounting bracket	395
Adjustable mud wing mounting brackets	396
Mud wings / mudguards	397
Subframe and cable clip brackets	398

Engine Frame

Roof panel

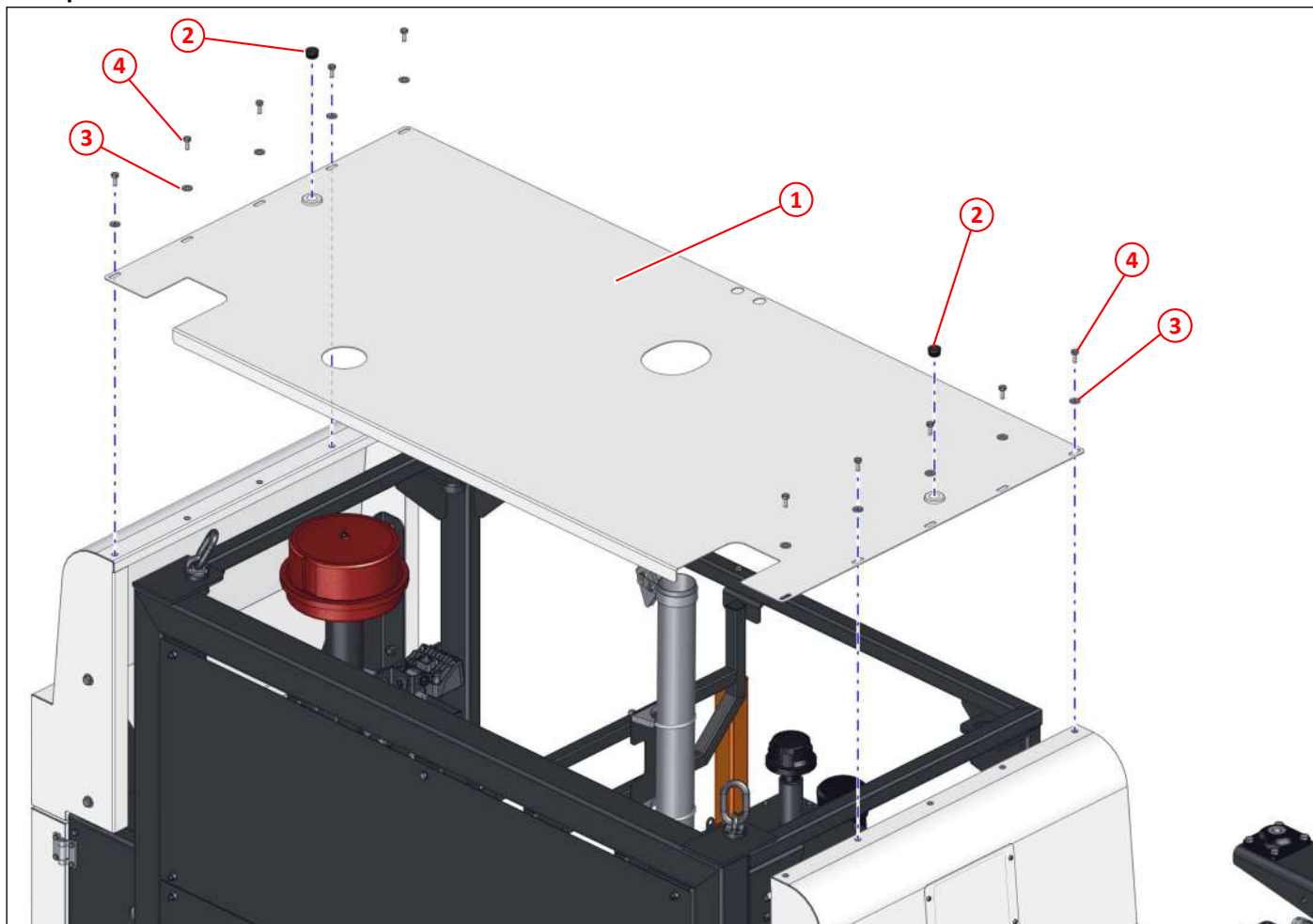

Figure 320: Roof panel

Item	Part No	Qty	Description
①	048689	1	Roof panel
②	026173	2	Plastic plug $\varnothing 25.4$ (black)
③	011092	10	Washer M8
④	011010	10	Setscrew HT M8 x 20

Hopper extension wing, left hand

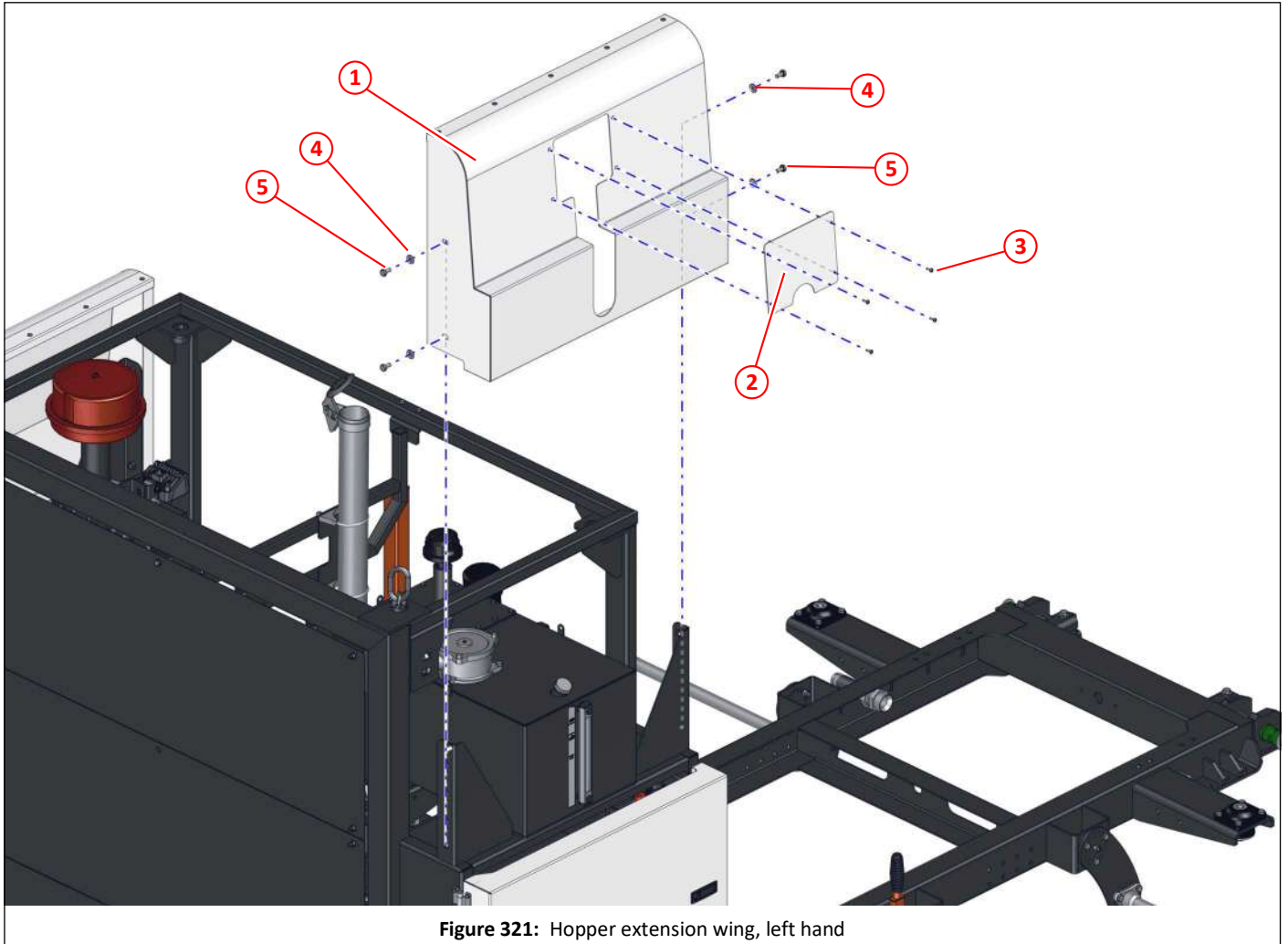

Figure 321: Hopper extension wing, left hand

Item	Part No	Qty	Description	
①	046910	1	Hopper extension wing, left hand, engine frame	
②	047911	1	Oil fill cover	
③	000373	4	Socket dome head screw M6 x 16, stainless steel	
④	011094	4	Washer M10	
⑤	011030	4	Setscrew HT M10 x 20	

Hopper extension wing, right hand

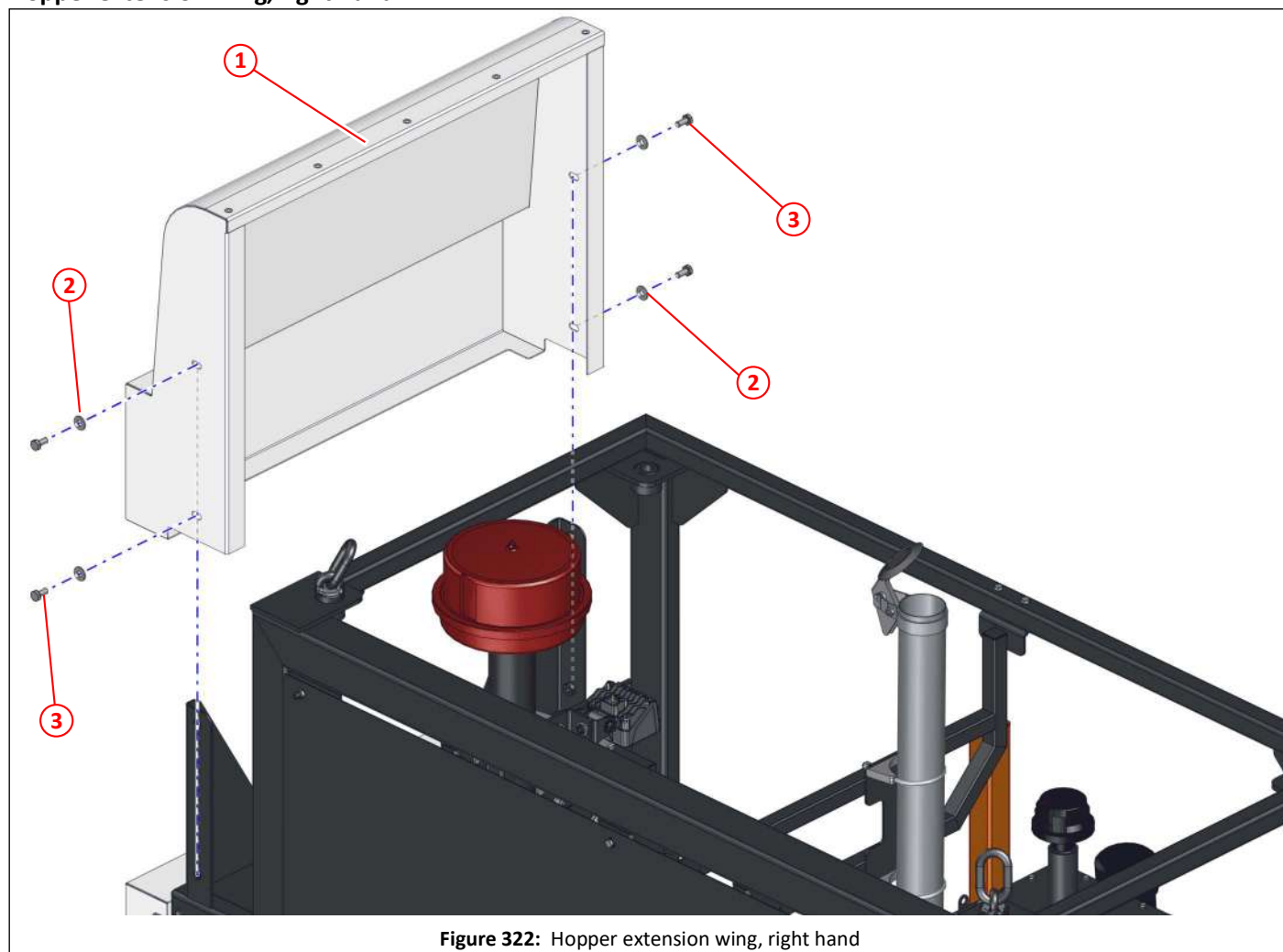

Figure 322: Hopper extension wing, right hand

Item	Part No	Qty	Description
①	047367	1	Hopper extension wing, right hand, engine cover
②	011094	4	Washer M10
③	011030	4	Setscrew HT M10 x 20

Front door, left hand

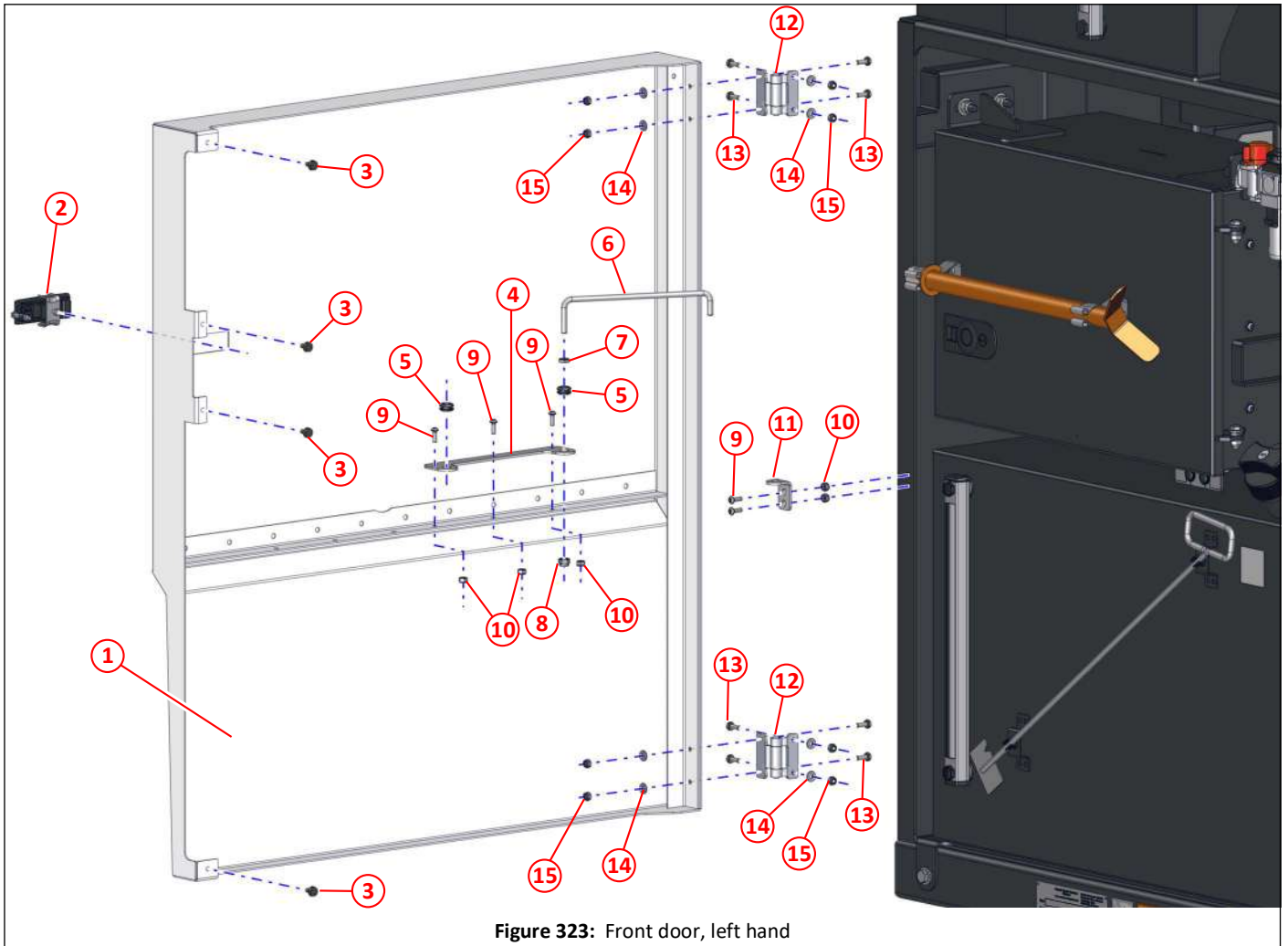

Figure 323: Front door, left hand

Item	Part No	Qty	Description
①	046907	1	Front door, left hand, engine frame
②	035662	1	Panel latch, locking
③	042506	4	Rubber foot, push on
④	046719	1	Door stay mount
⑤	011756	2	Grommet $\phi 19.1 \times \phi 12.7 \times 3.2 \times \phi 7.9$
⑥	044407	1	Door stay
⑦	000516	1	Half nut M8, stainless steel
⑧	000263	1	Nyloc nut M8, stainless steel
⑨	000373	5	Socket dome head screw M6 x 16, stainless steel
⑩	000253	5	Nyloc nut T M6, stainless steel
⑪	046720	1	Bracket, door stay
⑫	028583	2	Hinge
⑬	011001	8	Setscrew HT M6 x 16
⑭	011090	8	Washer M6
⑮	011071	8	Nyloc nut T M6

Front door, right hand

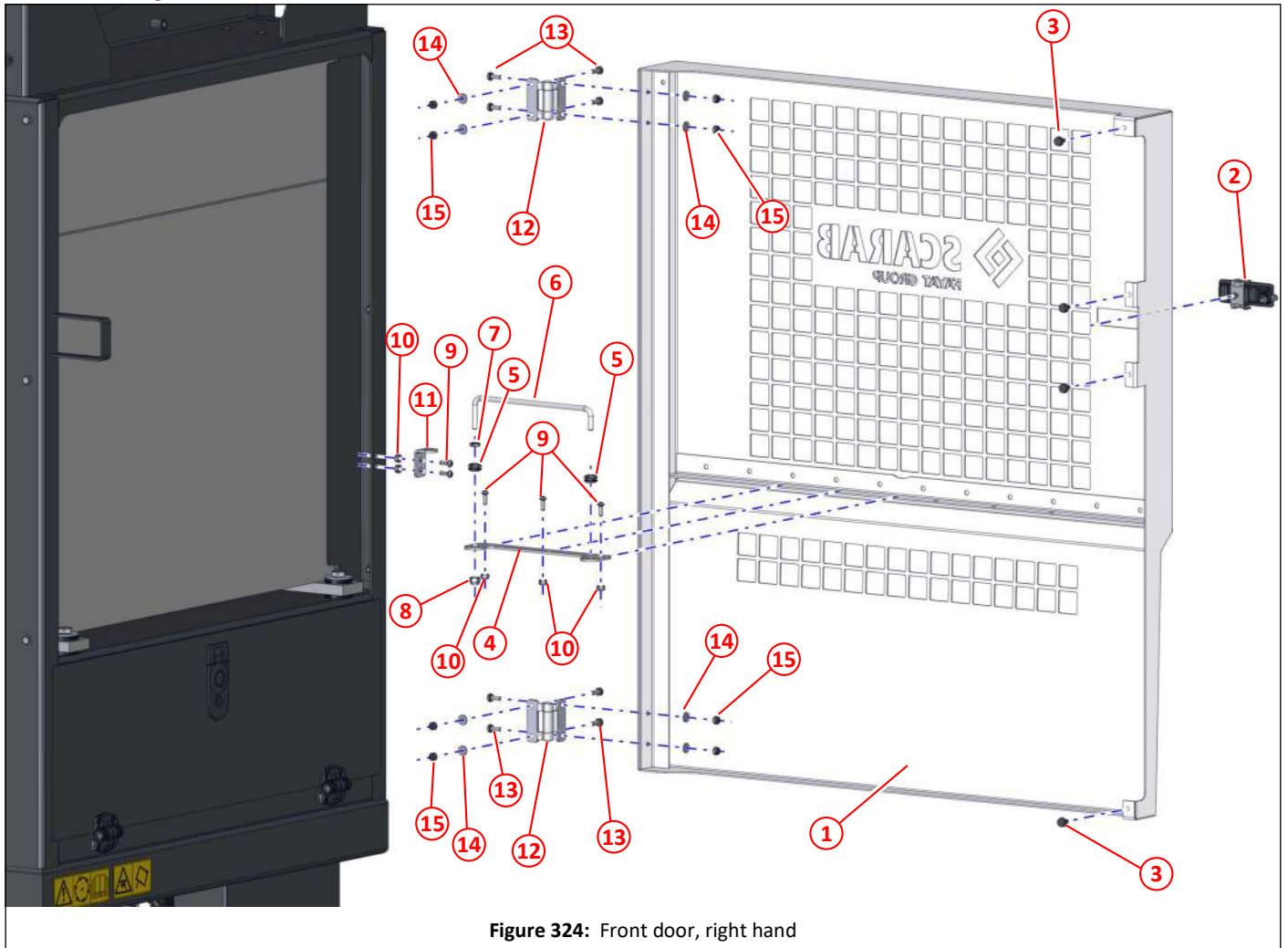

Figure 324: Front door, right hand

Item	Part No	Qty	Description
①	048694	1	Front door, right hand, engine frame
②	035662	1	Panel latch, locking
③	042506	4	Rubber foot, push on
④	046719	1	Door stay mount
⑤	011756	2	Grommet $\phi 19.1 \times \phi 12.7 \times 3.2 \times \phi 7.9$
⑥	044407	1	Door stay
⑦	000516	1	Half nut M8, stainless steel
⑧	000263	1	Nyloc nut M8, stainless steel
⑨	000373	5	Socket dome head screw M6 x 16, stainless steel
⑩	000253	5	Nyloc nut T M6, stainless steel
⑪	046720	1	Bracket, door stay
⑫	028583	2	Hinge
⑬	011001	8	Setscrew HT M6 x 16
⑭	011090	8	Washer M6
⑮	011071	8	Nyloc nut T M6

End panels

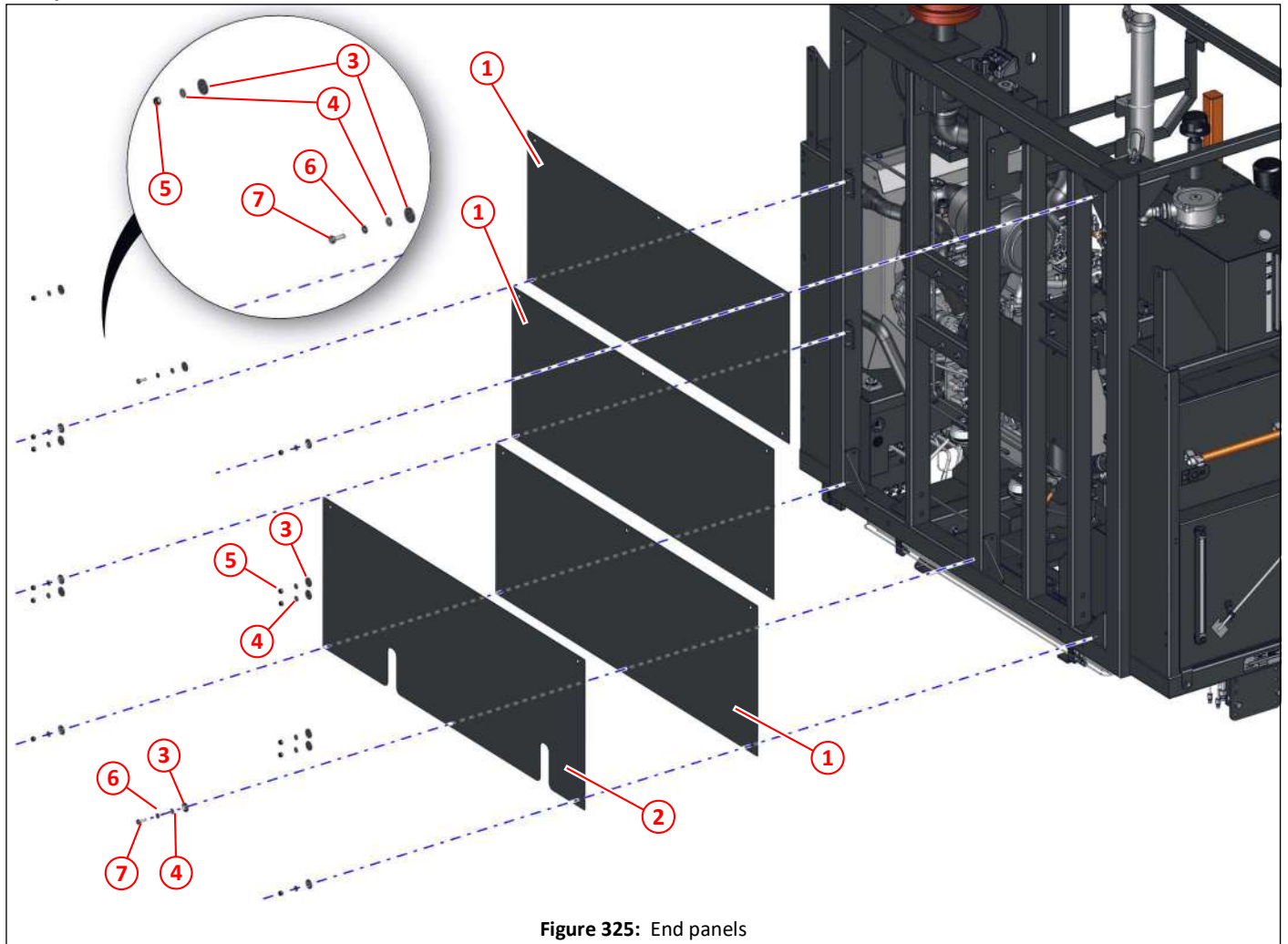

Figure 325: End panels

Item	Part No	Qty	Description
①	044867	3	End panel, standard, engine frame
②	043464 *	1	End panel, auxiliary water tank, engine frame
③	046555	14	Rubber washer $\varnothing 30 \times \varnothing 8.5 \times 3$
④	000419	14	Washer M8
⑤	011073	12	Nyloc nut T M8
⑥	011093	2	Spring washer M8
⑦	011011	2	Setscrew HT M8 x 25

*. Used instead of one standard end panel if auxiliary water tank is fitted.

Hydraulic oil tank mounting

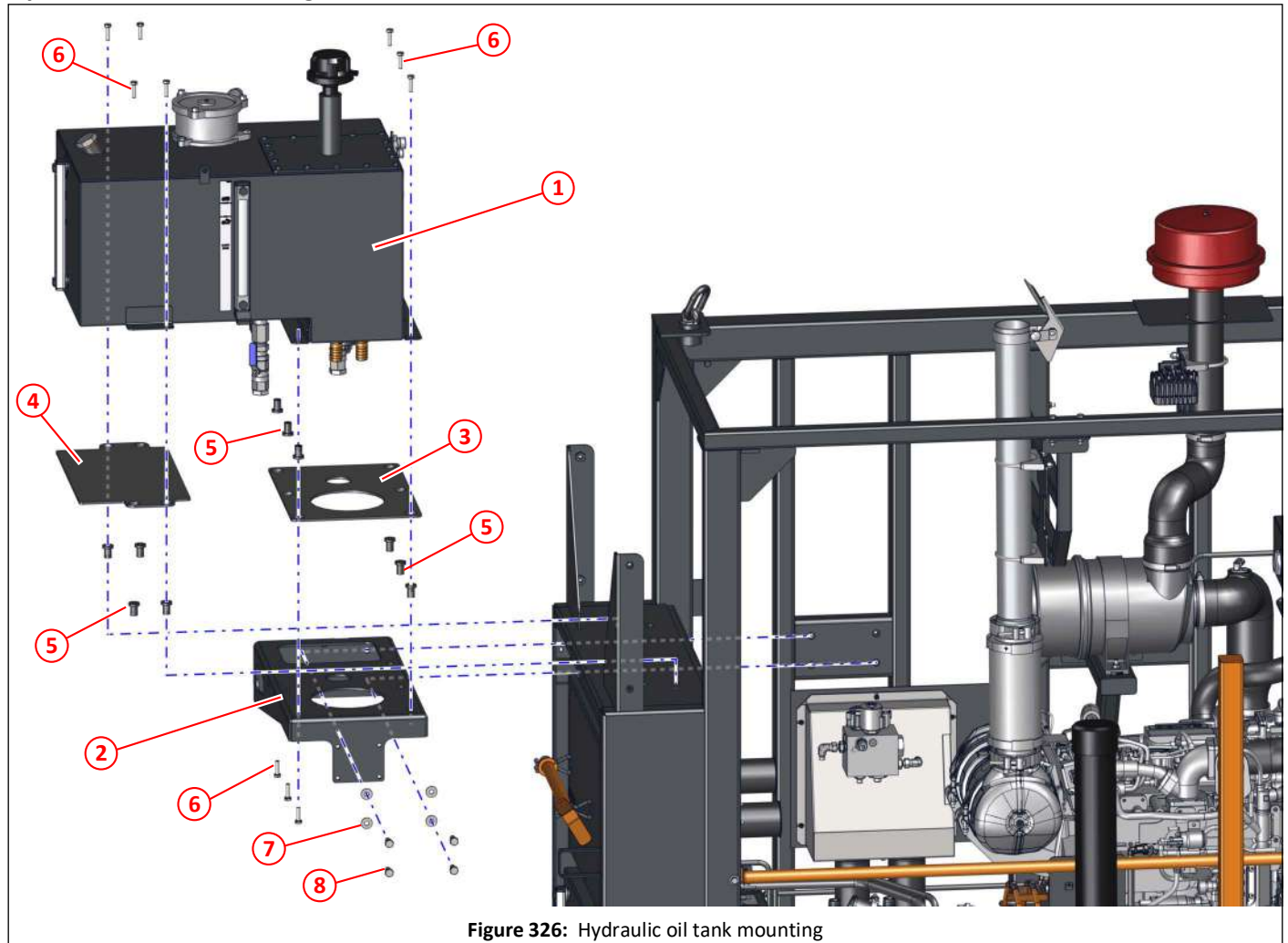

Figure 326: Hydraulic oil tank mounting

Item	Part No	Qty	Description	
①	046940	1	Hydraulic oil tank	262,263,264,265
②	046941	1	Oil tank bracket	
③	046942	1	Mat 1, oil tank	
④	046943	1	Mat 2, oil tank	
⑤	039932	10	Flex-Loc anti-vibration fastener M8	
⑥	011012	10	Setscrew HT M8 x 30	
⑦	011094	4	Washer M10	
⑧	011031	4	Setscrew HT M10 x 25	

Node-pneumatics cabinet mounting

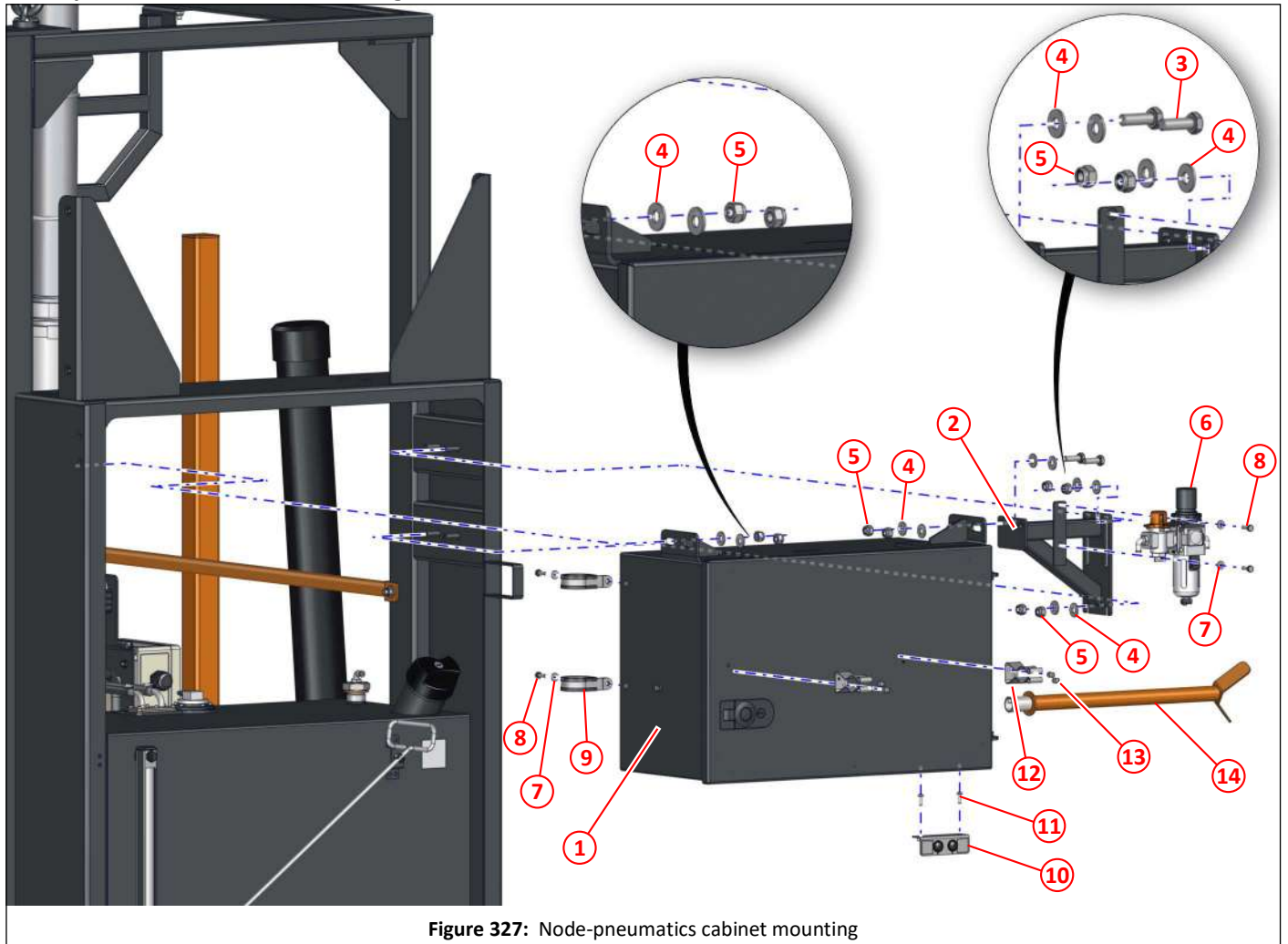

Figure 327: Node-pneumatics cabinet mounting

Item	Part No	Qty	Description
①		1	Node-pneumatics cabinet (HAF)
②	046958	1	Node-pneumatics cabinet support
③	011032	2	Setscrew HT M10 x 30
④	011094	10	Washer M10
⑤	011075	8	Nyloc nut T M10
⑥	032519	1	Air filter regulator AC30-MKK014
⑦	011090	4	Washer M6
⑧	011067	4	Setscrew HT M6 x 20
⑨	005055	2	Clip ø50 ID
⑩		1	Air purge controls
⑪	000338	2	Socket button head screw HD M6 x 16
⑫	014806	2	Clip, broom
⑬	011131	4	Seal blind rivet ø4.8 x 18
⑭	039683	1	Prop, hopper rear door

Fuel tank mounting

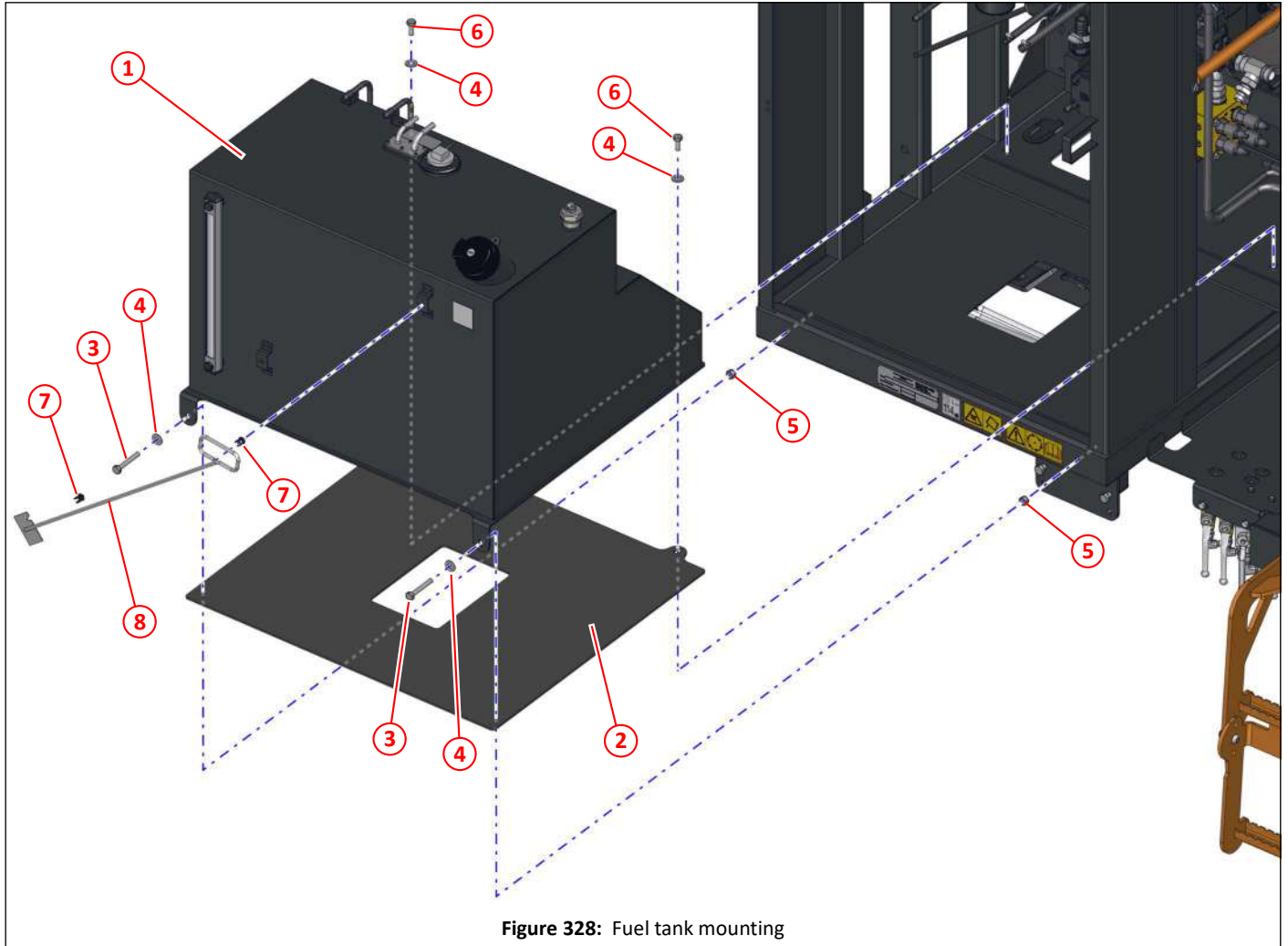

Figure 328: Fuel tank mounting

Item	Part No	Qty	Description	
①	046936	1	Fuel tank assembly	365
②	046954	1	Mat, fuel tank	
③	011037	2	Bolt HT M10 x 65	
④	011094	4	Washer M10	
⑤	011075	2	Nyloc nut T M10	
⑥	011031	2	Setscrew HT M10 x 25	
⑦	013631	2	Fir tree clip	
⑧	013514	1	Fan scraper	

Fuel tank

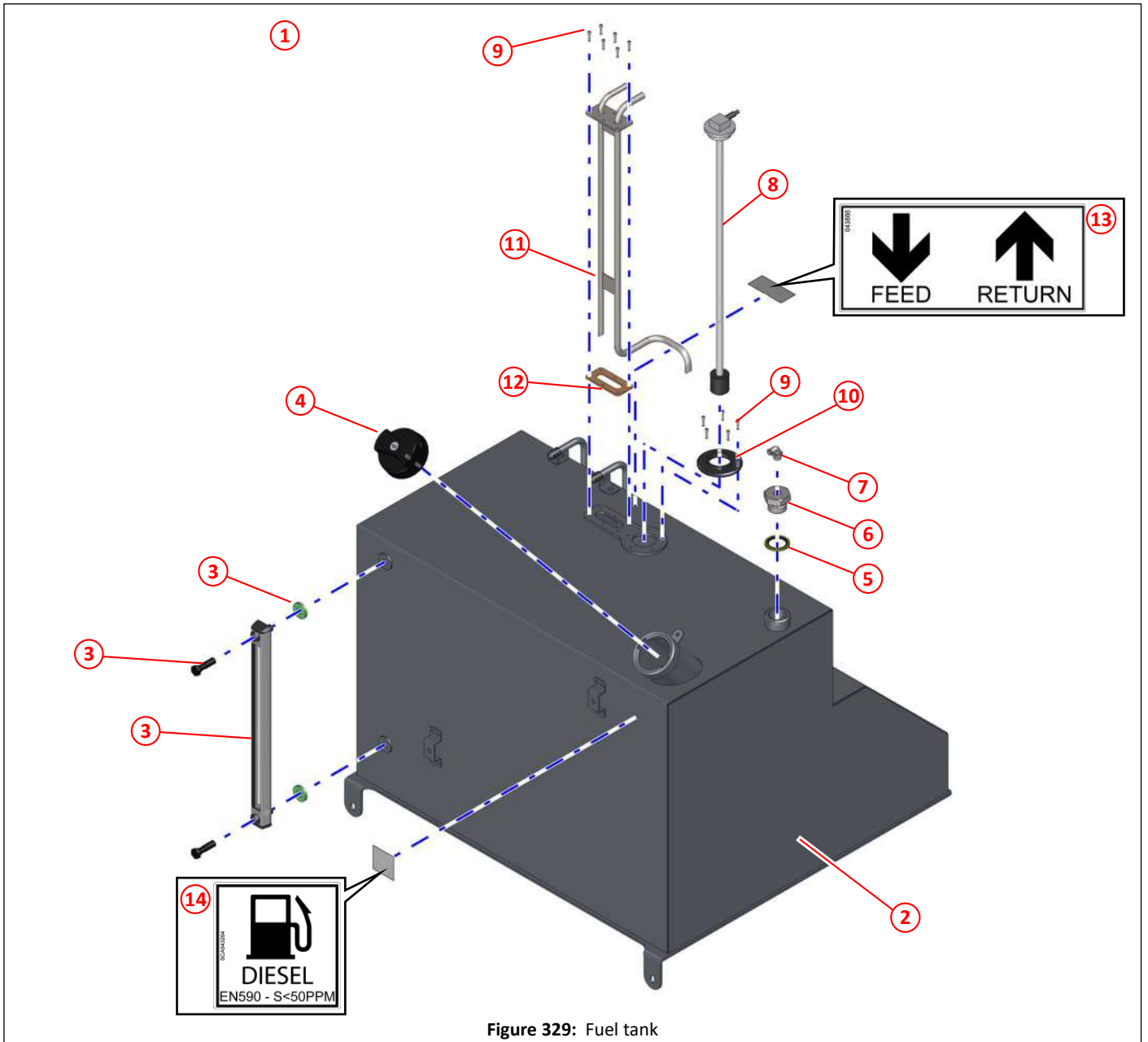

Figure 329: Fuel tank

Item	Part No	Qty	Description	
①	046936	1	Fuel tank assembly	364
②	046933	1	Fuel tank	
③	047922	1	Level gauge	
④	033228	1	Fuel locking cap, assembly	
⑤	011156	1	Dowty seal 1" BSP	
⑥	020689	1	Filler plug	
⑦	023203	1	Push in elbow, swivel, 6mm x 1/4" BSP	
⑧	046934	1	Fuel sender	
⑩	000142	11	socket cap head, screw M4 x 15, plated	
⑩	028840	1	Fuel sender fitting kit	
⑪	046935	1	Fuel tank feed / return	
⑫	031189	1	Fuel feed seal	
⑬	043866	1	Label - Fuel feed / return	
⑭	043264	1	Label - Diesel	

Combined intercooler/radiator/hydraulic oil cooler blanking

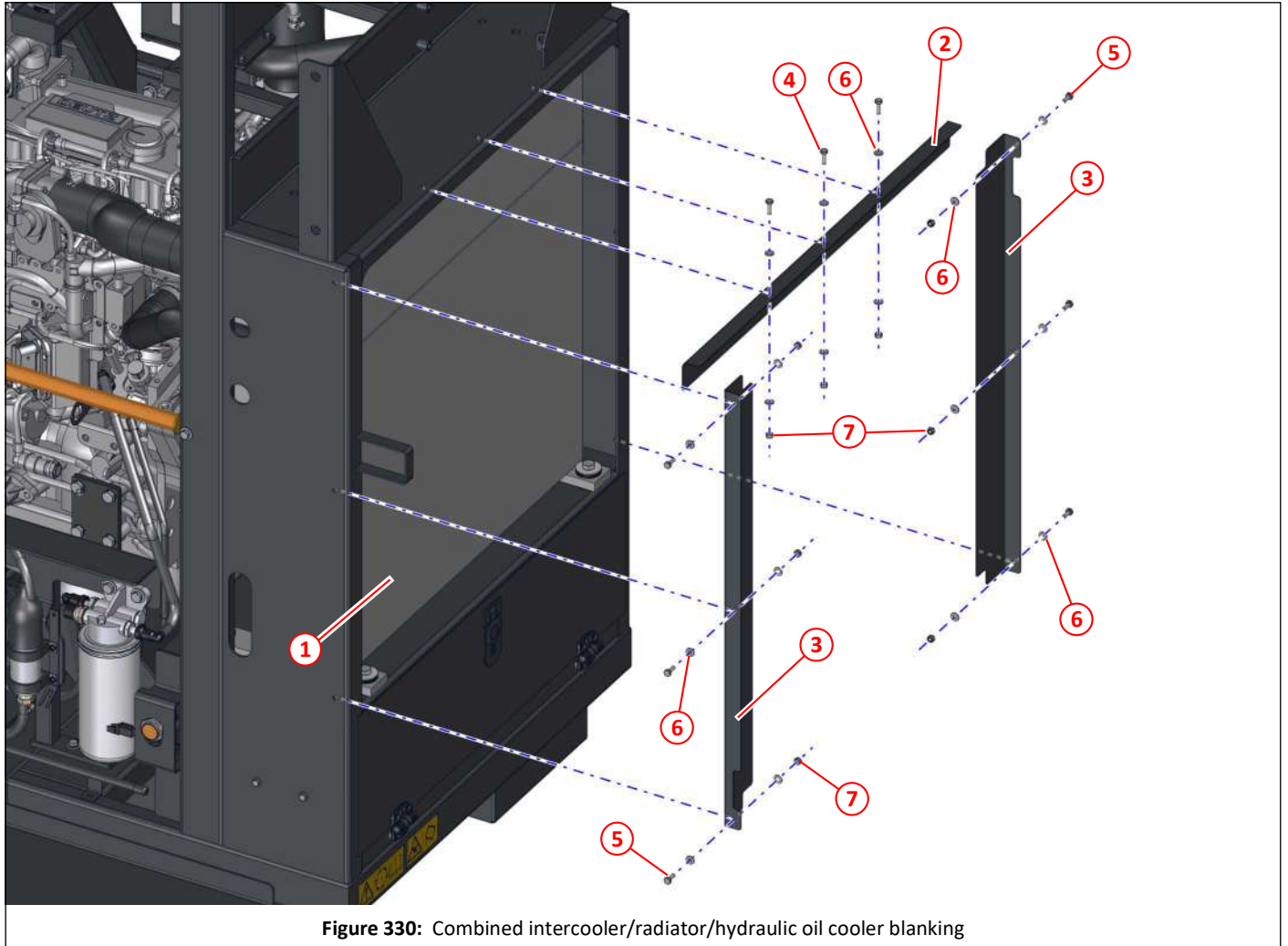

Figure 330: Combined intercooler/radiator/hydraulic oil cooler blanking

Item	Part No	Qty	Description	
①	046549	1	Combined intercooler/radiator/hydraulic oil cooler	416
②	048697	1	Blanking plate top, cooler	
③	047306	2	Blanking plate side, cooler	
④	011067	3	Setscrew HT M6 x 20	
⑤	011001	6	Setscrew HT M6 x 16	
⑥	011090	18	Washer M6	
⑦	011071	9	Nyloc nut T M6	

Combined intercooler/radiator/hydraulic oil cooler mounting

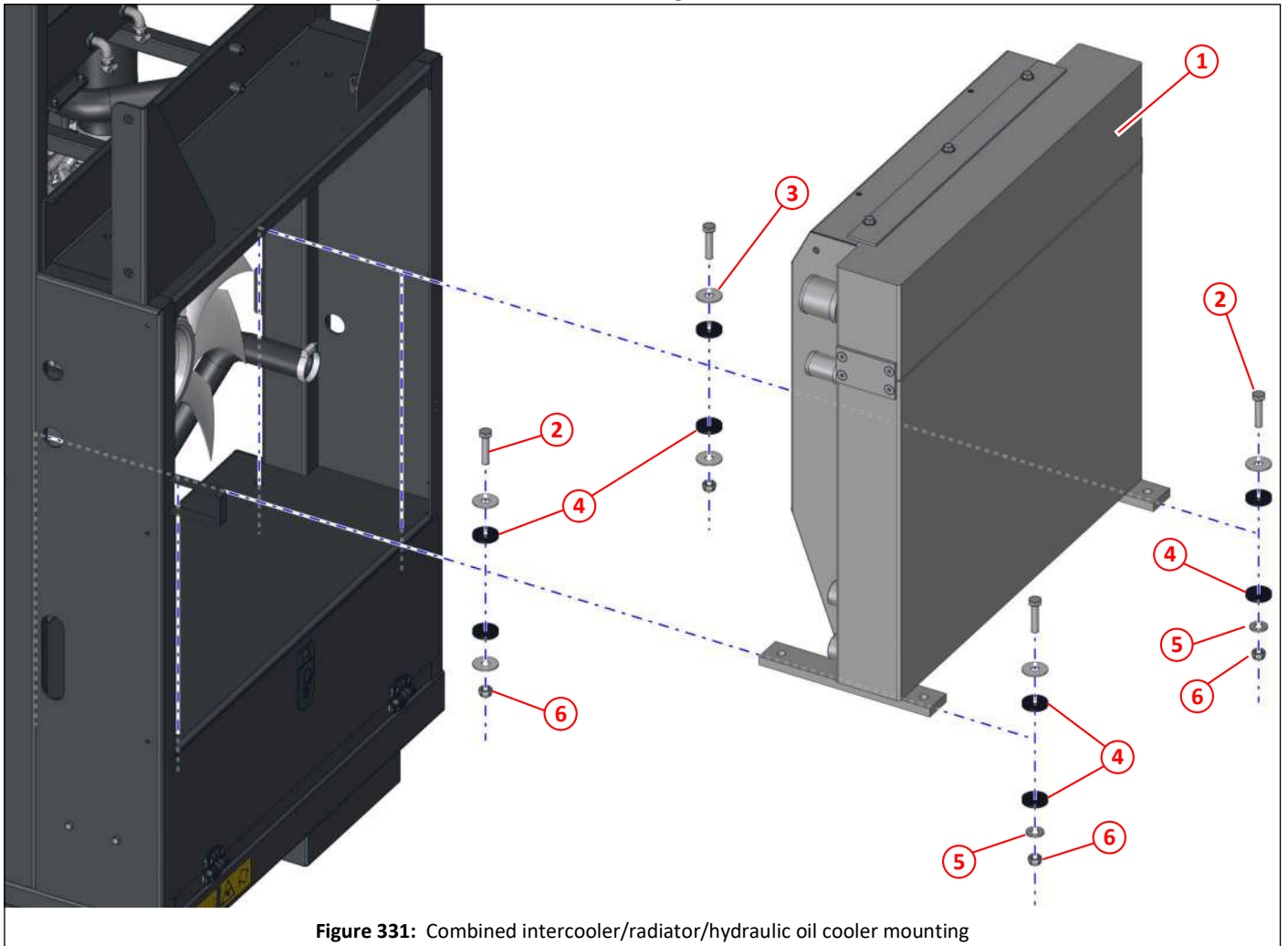

Figure 331: Combined intercooler/radiator/hydraulic oil cooler mounting

Item	Part No	Qty	Description	
①	046549	1	Combined intercooler/radiator/hydraulic oil cooler	416
②	000024	4	Setscrew HT M12 x 50	
③	013448	6	Washer $\phi 40 \times \phi 13$ 2	
④	012969	8	Rubber washer $\phi 40 \times \phi 12 \times 6$	
⑤	011096	2	Washer M12	
⑥	011077	4	Nyloc nut T M12	

Safety bar

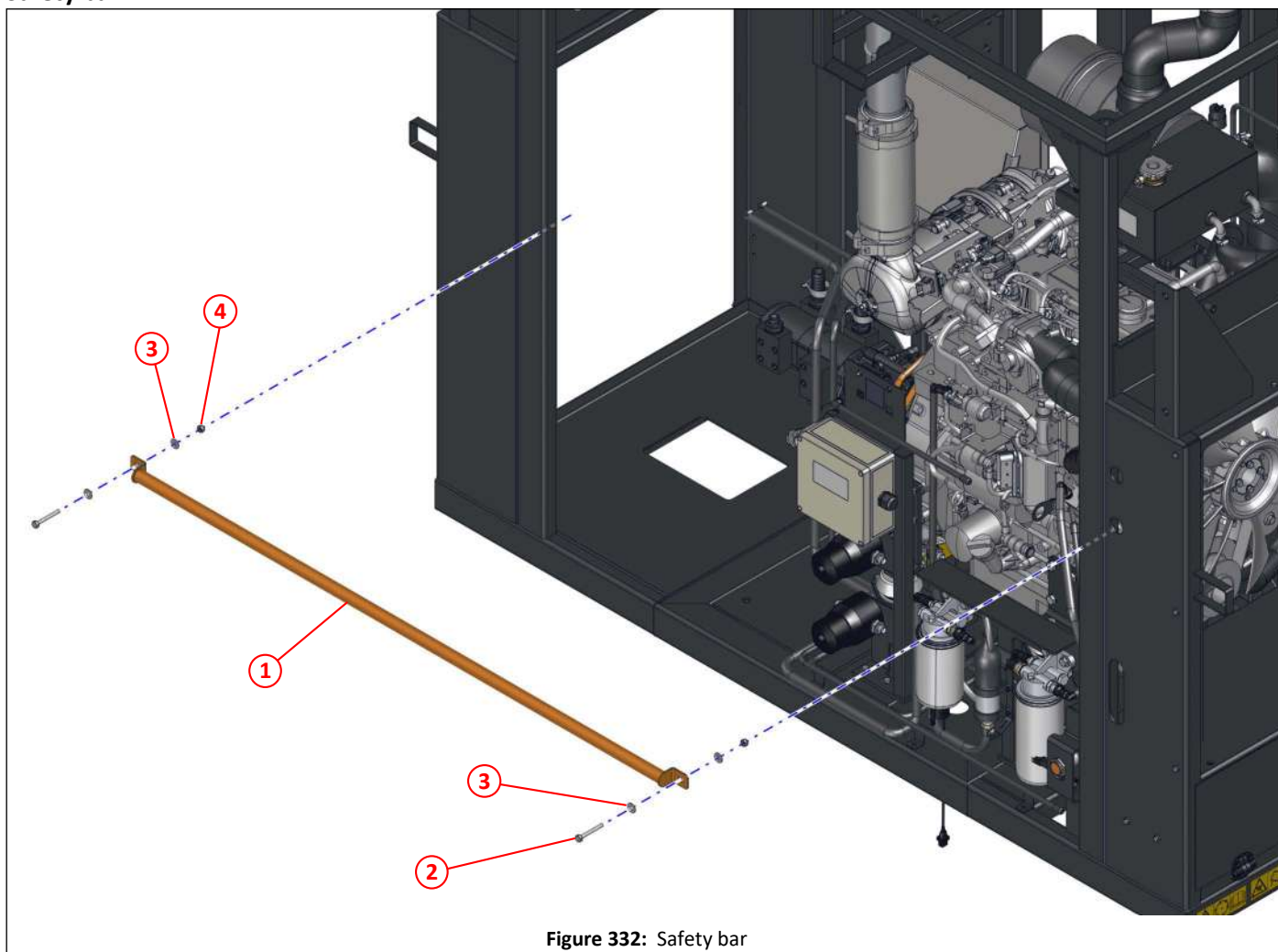

Figure 332: Safety bar

Item	Part No	Qty	Description
①	034800	1	Safety bar, engine frame
②	011017	2	Bolt HT M8 x 60
③	011092	4	Washer M8
④	011073	2	Nyloc nut T M8

Battery junction box and oil filter mounting

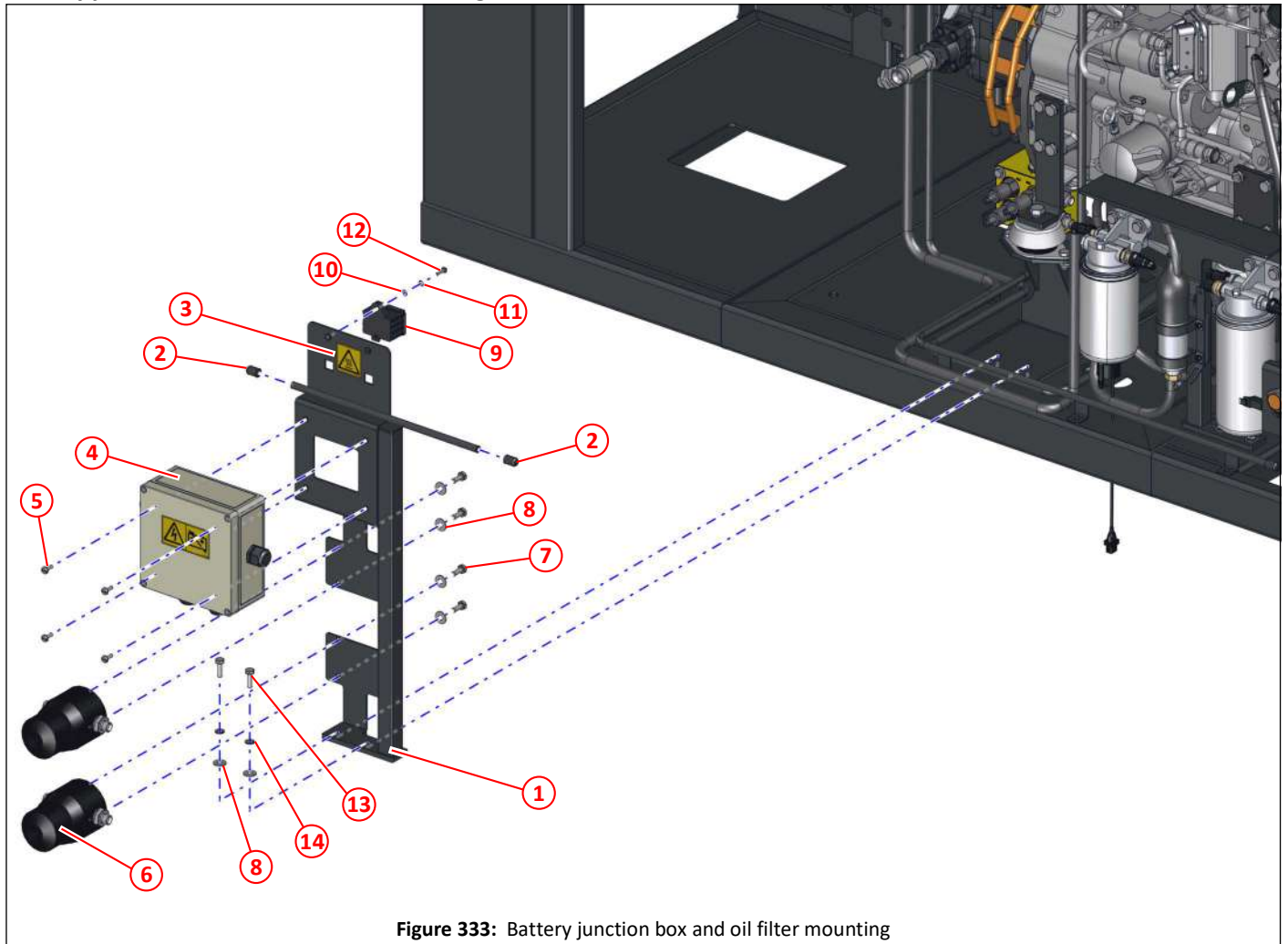

Figure 333: Battery junction box and oil filter mounting

Item	Part No	Qty	Description
①	042957	1	Mount, junction box
②	043065	2	Pipe cap \varnothing 12
③	043266	1	Label - Warning - Electrical
④	043350	1	Battery junction box
⑤	011110	4	Pan head screw M6 x 16
⑥	025103	2	Filter, oil, high pressure
⑦	011010	4	Setscrew HT M8 x 20
⑧	011092	6	Washer M8
⑨	036844	1	Power connection link, black
⑩	000410	1	Washer M5
⑪	000411	1	Spring washer M5
⑫	000381	1	Socket dome head screw M5 x 20, stainless steel
⑬	011011	2	Setscrew HT M8 x25
⑭	011093	2	Spring washer M8

Fuel filters and fuel pump mounting

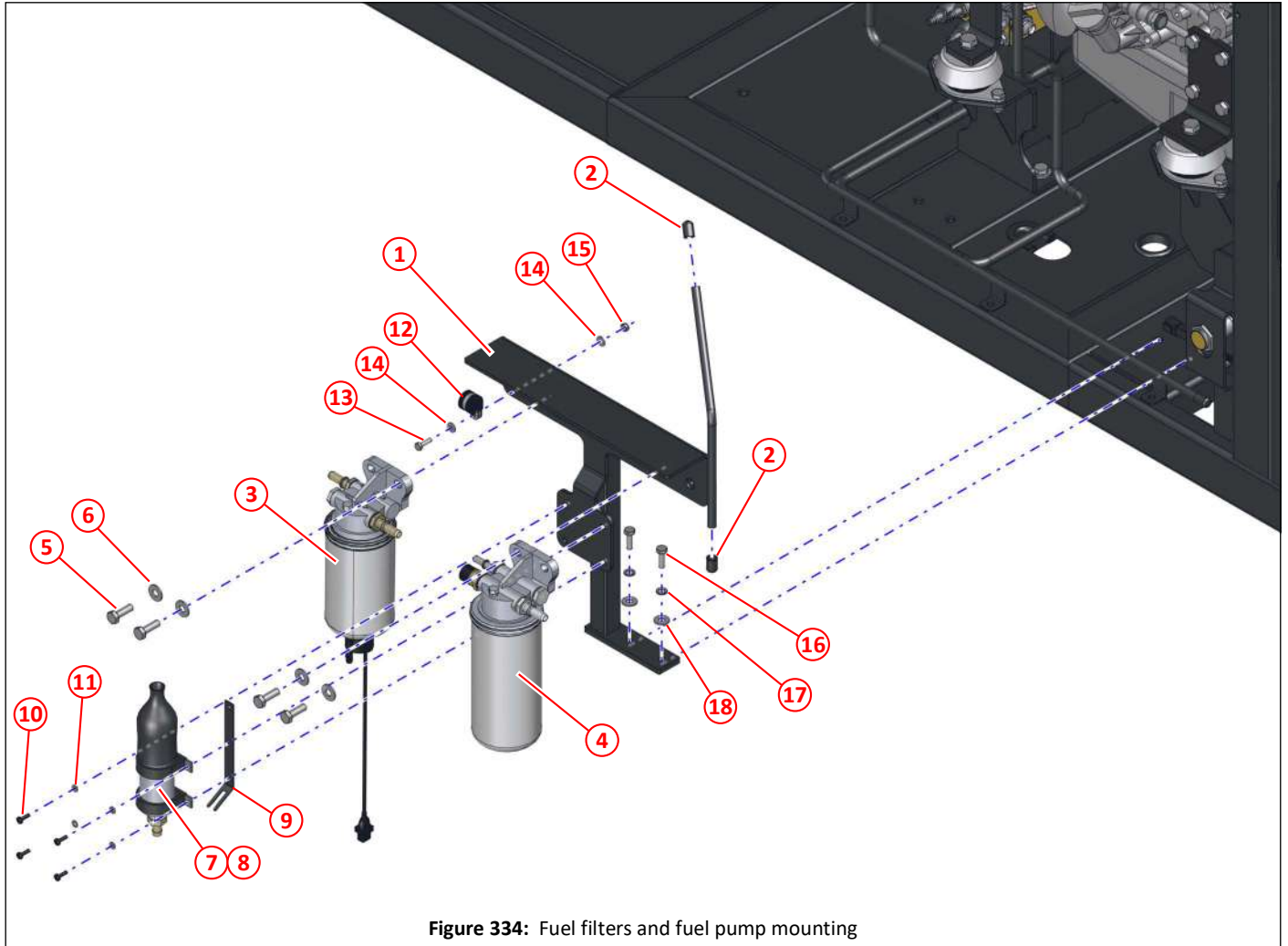

Figure 334: Fuel filters and fuel pump mounting

Item	Part No	Qty	Description	
①	042955	1	Mounting bracket, fuel system, engine frame	
②	043065	2	Pipe cap $\varnothing 12$	
③	042234	1	Fuel filter, primary	411
④	043786	1	Fuel filter, secondary	411
⑤	011032	4	Setscrew HT M10 x 30	
⑥	011094	4	Washer M10	
⑦	044515	1	Fuel lift pump, 12V	411
⑧	043370	1	Fuel lift pump, 24V	411
⑨	043193	1	Fuel filter connector bracket	
⑩	000234	4	Pan head Pozidriv setscrew M5 x 16, black	
⑪	000410	4	Washer M5	
⑫	000200	1	Clip $\varnothing 18$, rubber sleeved	
⑬	011067	1	Setscrew HT M6 x 20	
⑭	011090	2	Washer M6	
⑮	011071	1	Nyloc nut T M6	
⑯	011011	2	Setscrew HT M8 x 25	
⑰	011093	2	Spring Washer M8	
⑱	011092	2	Washer M8	

Hopper raise proximity sensor

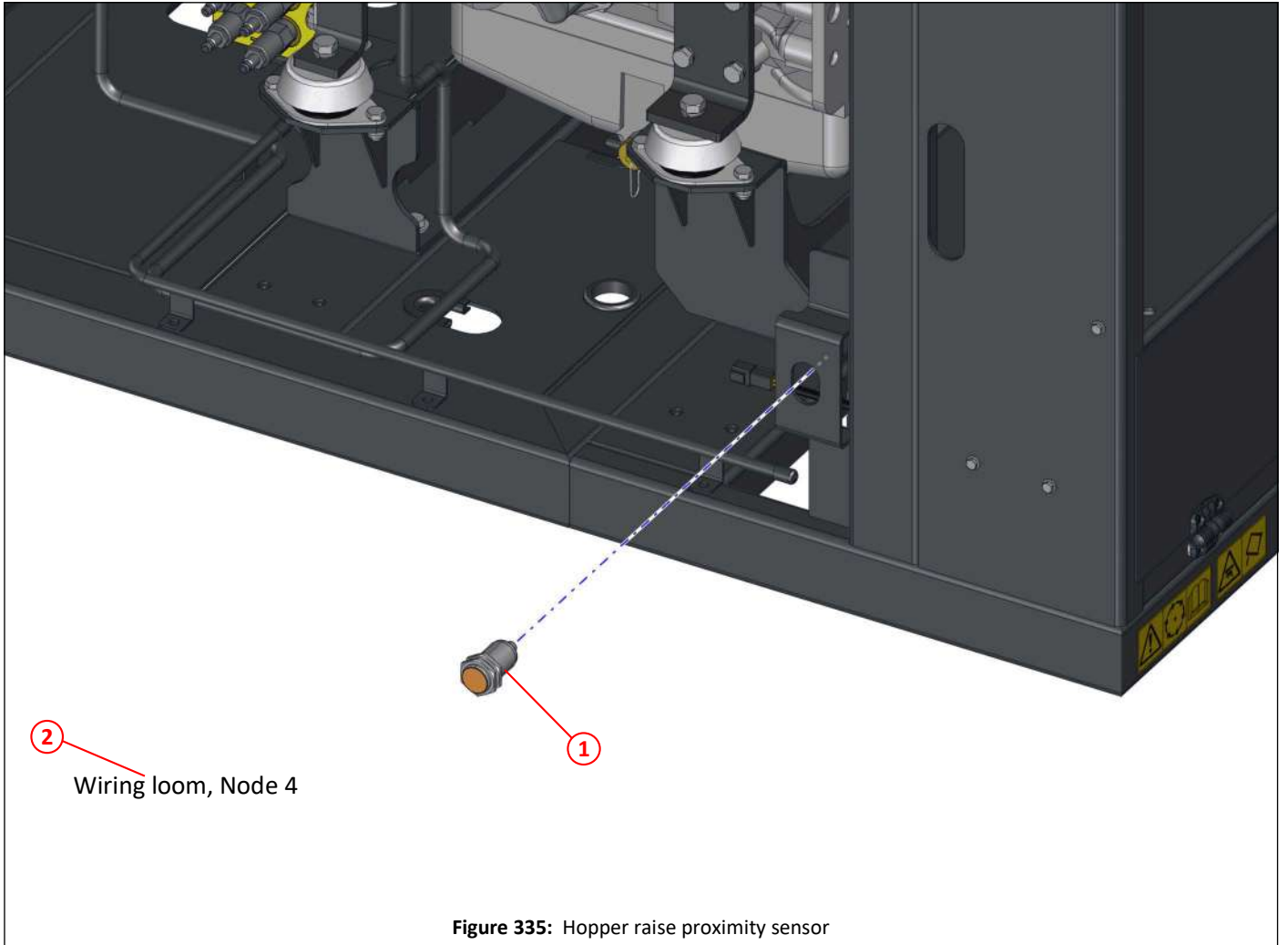

Figure 335: Hopper raise proximity sensor

Item	Part No	Qty	Description	
①	032627	1	Hopper raise proximity sensor	
②	047384	1	Wiring loom, Node 4	

Exhaust stack mounting

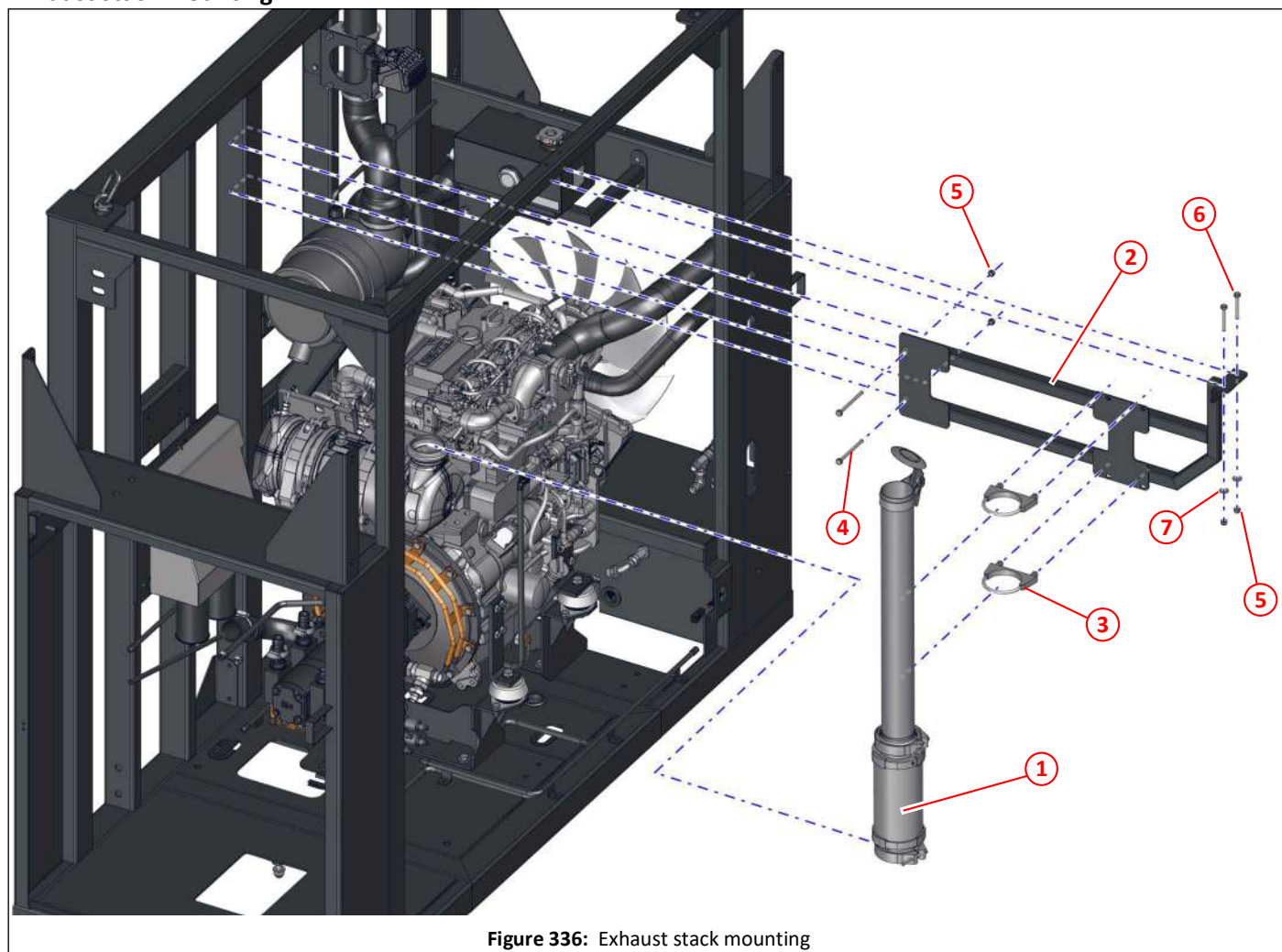

Figure 336: Exhaust stack mounting

Item	Part No	Qty	Description	
①		1	Exhaust stack	412
②	046944	1	Support bracket, exhaust stack, engine frame	
③	036831	2	U clamp, exhaust, ø83	
④	011020	2	Bolt M8 x 80	
⑤	011073	4	Nyloc nut T M8	
⑥	011017	2	Bolt HT M8 x 60	
⑦	011092	2	Washer M8	

Air intake stack mounting

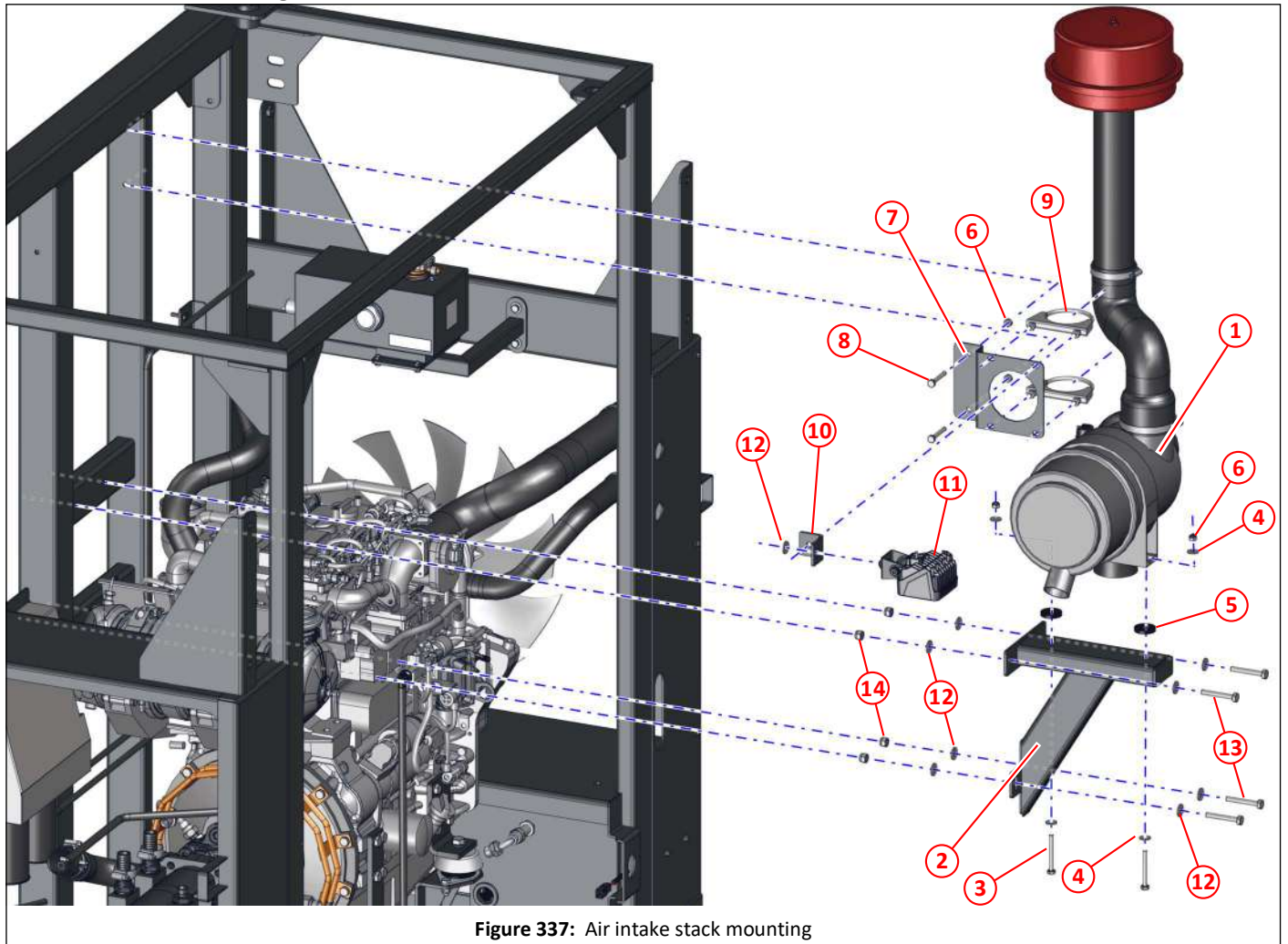

Figure 337: Air intake stack mounting

Item	Part No	Qty	Description	
①		1	Air intake stack	413,414
②	042920	1	Mounting bracket, air cleaner	
③	011018	2	Bolt HT M8 x 70	
④	011092	4	Washer M8	
⑤	012969	2	Rubber washer ø40 x ø12 x 6	
⑥	011073	4	Nyloc nut T M8	
⑦	046948	1	Bracket, air stack	
⑧	000009	2	Bolt HT M8 x 55	
⑨	036831	2	U clamp, exhaust, ø83	
⑩	012548	1	Angle bracket	
⑪	047757	1	Work lamp, 18W 10-32V	
⑫	011094	9	Washer M10	
⑬	011037	4	Bolt HT M10 x 65	
⑭	011075	4	Nyloc nut T M10	

Coolant expansion tank mounting

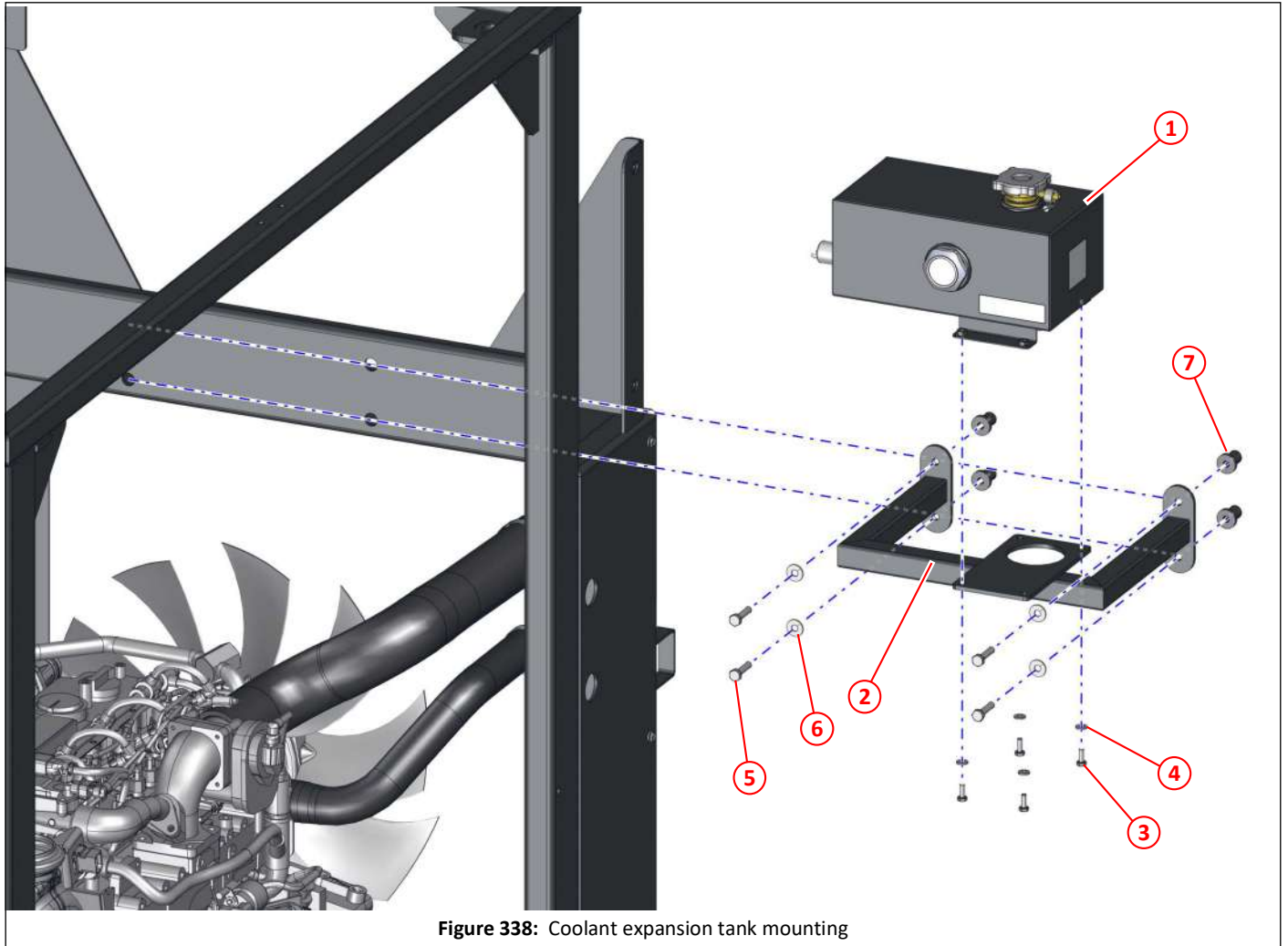

Figure 338: Coolant expansion tank mounting

Item	Part No	Qty	Description	
①	041936	1	Coolant expansion tank	415
②	046946	1	Mounting bracket, coolant expansion tank	
③	011001	4	Setscrew HT M6 x 16	
④	011090	4	Washer M6	
⑤	011013	4	Setscrew HT M8 x35	
⑥	011092	4	Washer M8	
⑦	039932	4	Flex-Loc anti-vibration fastener M8	

Remote mounted flow control valve mounting

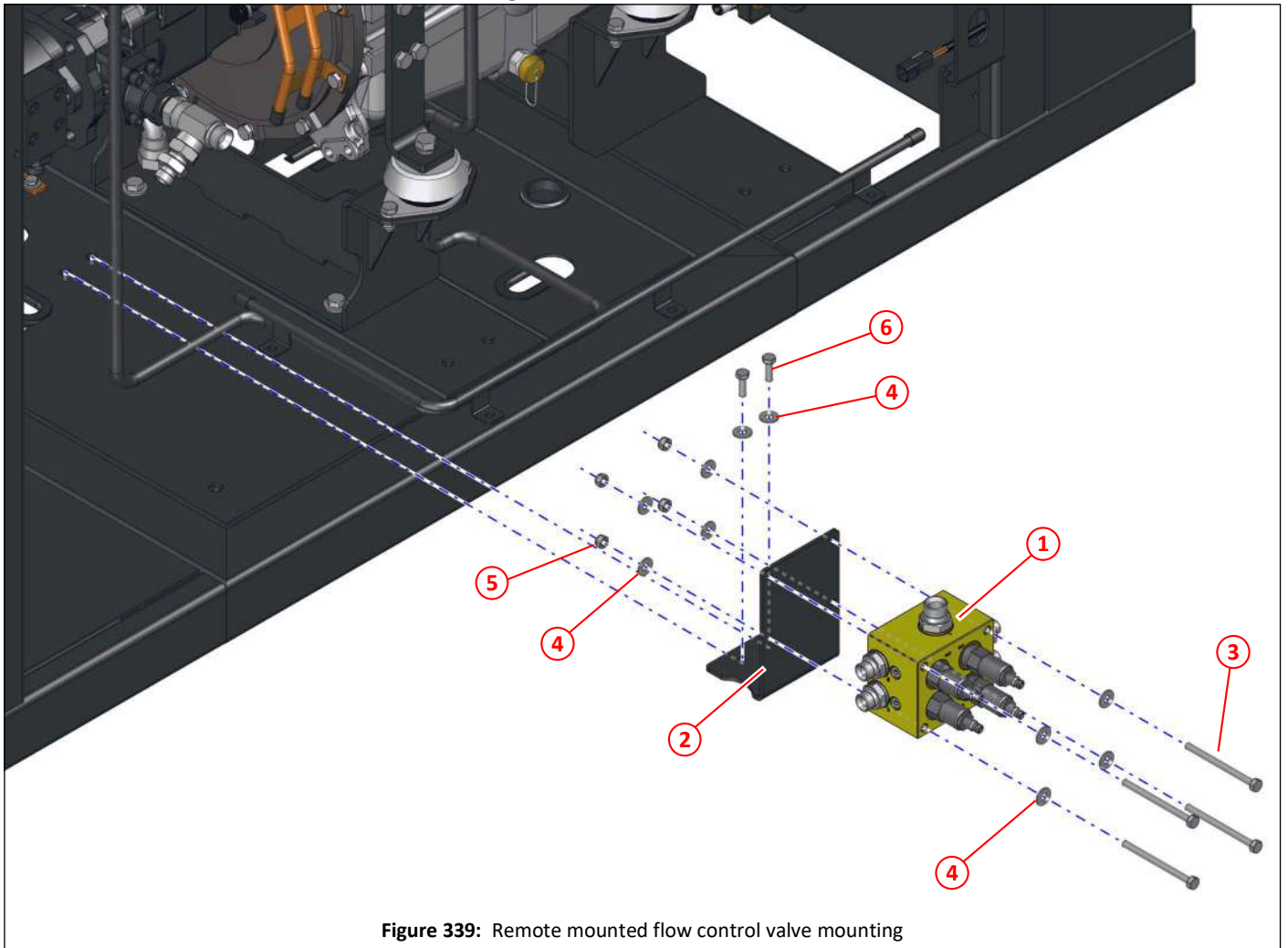

Figure 339: Remote mounted flow control valve mounting

Item	Part No	Qty	Description	
①	038513	1	Remote mounted flow control valve assembly, dual	271,272
②	046973	1	Bracket, Remote mounted flow control	
③	011020	4	Bolt M8 x 80	
④	011092	10	Washer M8	
⑤	011073	4	Nyloc nut T M8	
⑥	011011	2	Setscrew HT M8 x25	

Rear engine mount

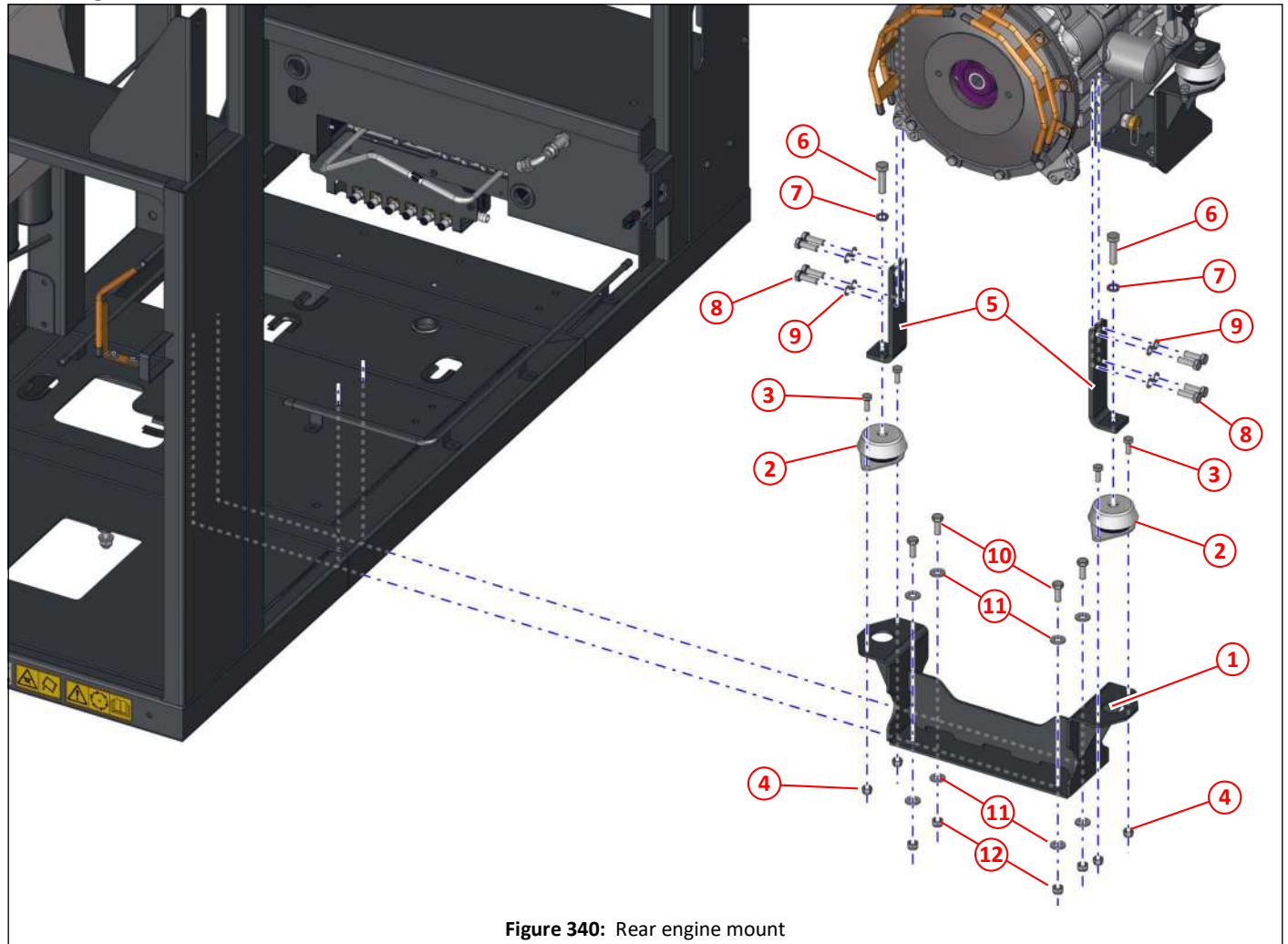

Figure 340: Rear engine mount

Item	Part No	Qty	Description	
①	042810	1	Engine cradle, rear	401
②	030724	2	Engine mount	402
③	011031	4	Setscrew HT M10 x25	
④	011075	4	Nyloc nut T M10	
⑤	042811	2	Engine mounting, rear	402
⑥	011403	2	Bolt M14 x 50	
⑦	011106	2	Spring washer M14	
⑧	011053	8	Setscrew HT M12 x 35	
⑨	011097	8	Spring washer M12	
⑩	011052	4	Setscrew HT M12 x 30	
⑪	011096	8	Washer M12	
⑫	011075	4	Nyloc nut T M10	

Front engine mount

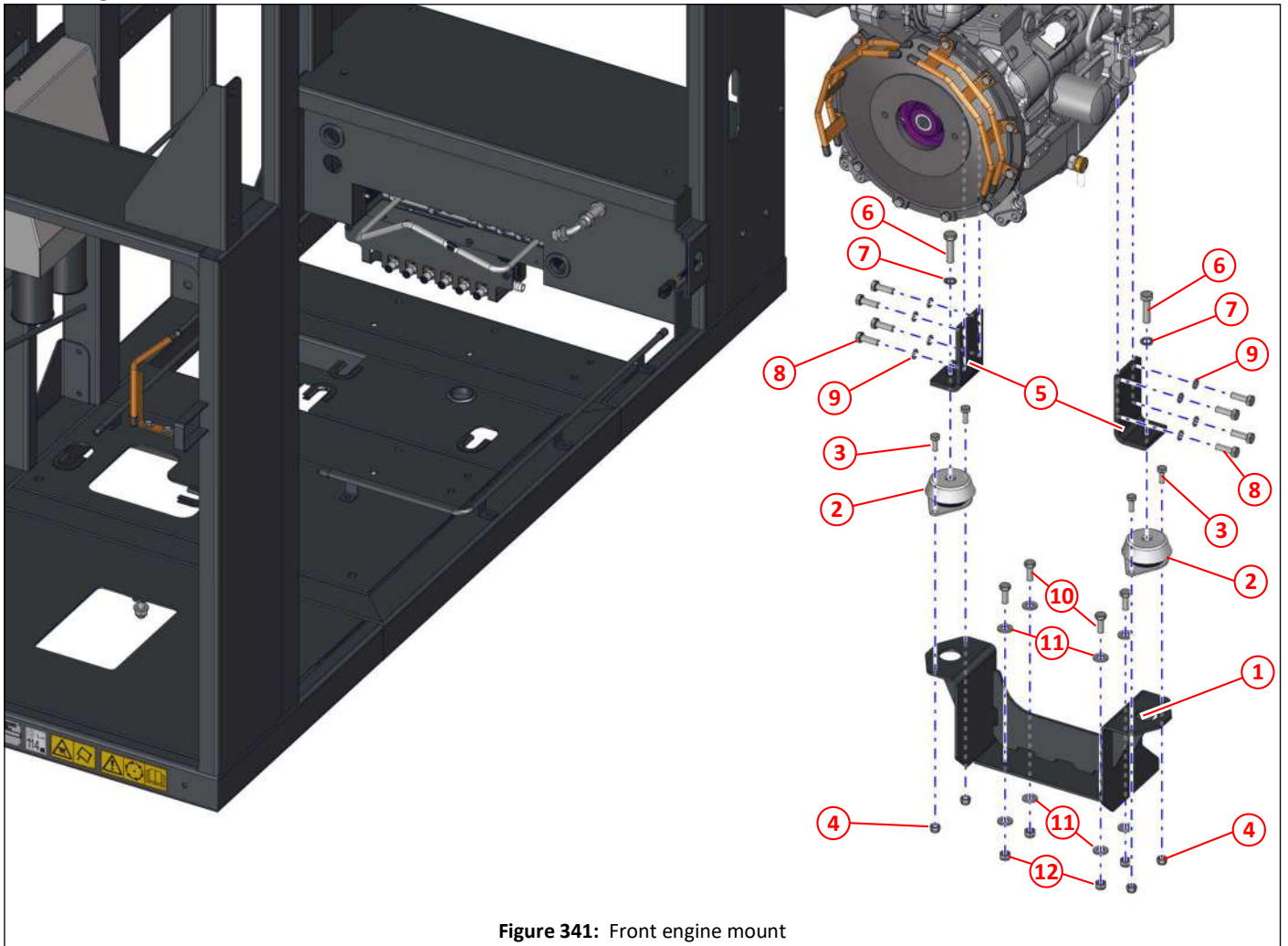

Figure 341: Front engine mount

Item	Part No	Qty	Description	
①	042810	1	Engine cradle, rear	401
②	030724	2	Engine mount	402
③	011031	4	Setscrew HT M10 x25	
④	011075	4	Nyloc nut T M10	
⑤	042808	2	Engine mounting, front	402
⑥	011403	2	Bolt M14 x 50	
⑦	011106	2	Spring washer M14	
⑧	011053	8	Setscrew HT M12 x 35	
⑨	011097	8	Spring washer M12	
⑩	011052	4	Setscrew HT M12 x 30	
⑪	011096	8	Washer M12	
⑫	011075	4	Nyloc nut T M10	

ECU cover

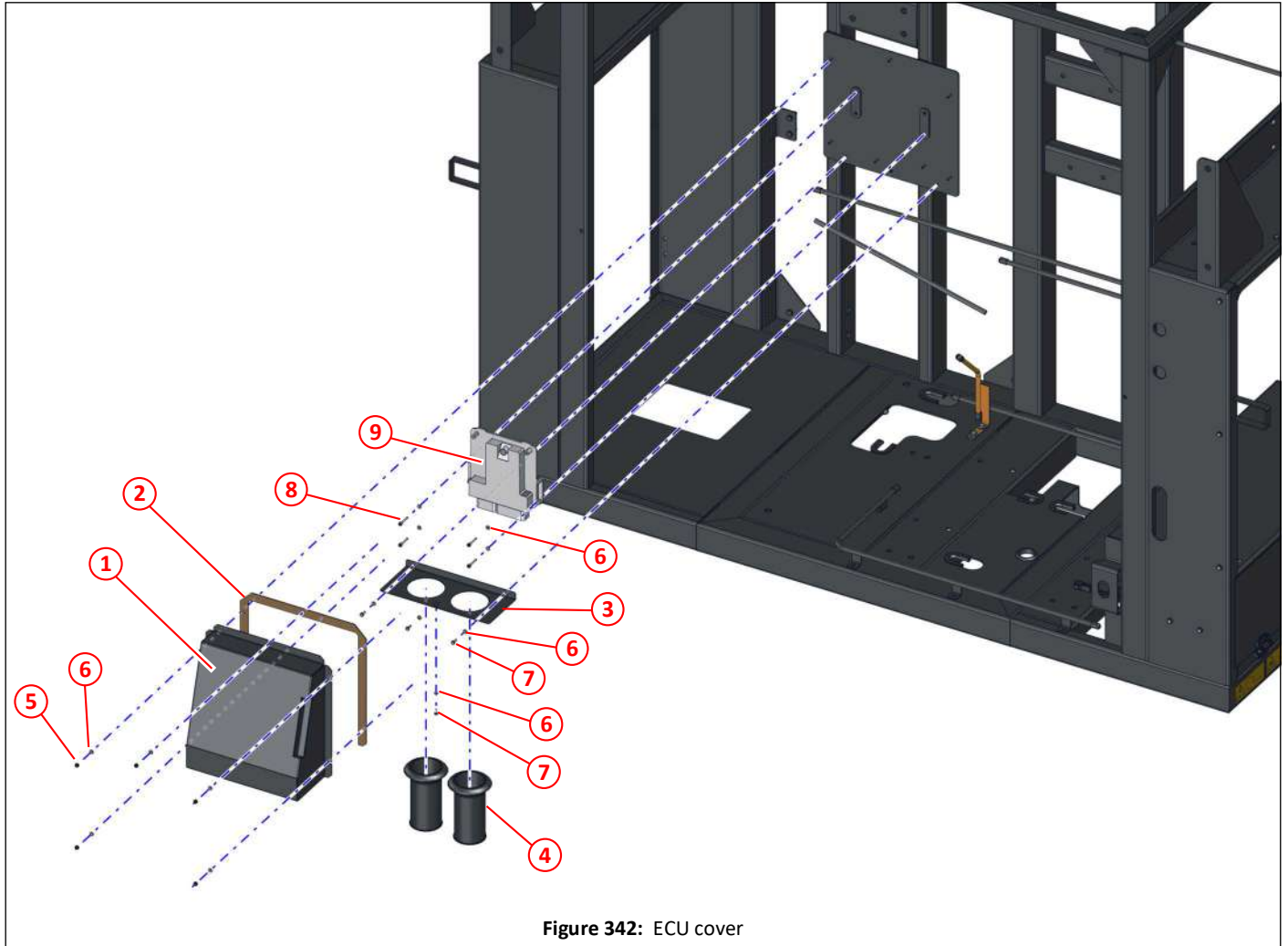

Figure 342: ECU cover

Item	Part No	Qty	Description	
①	042981	1	ECU cover	
②	042982	1	Gasket, ECU cover	
③	043302	1	Sock mount panel	
④	034807	2	Panel sock	
⑤	000155	5	Nyloc nut M5	
⑥	000410	13	Washer M5	
⑦	000097	4	Bolt M5 x 12	
⑧	000118	4	Socket cap head screw M5 x 30	
⑨	046220 *	1	ECU, DEUTZ engine 3.6 (Stage V), for both 12V and 24V.	410

*. The ECU will need to be matched to the serial number of the DEUTZ auxiliary engine of your vehicle.

Hydraulic cabinet

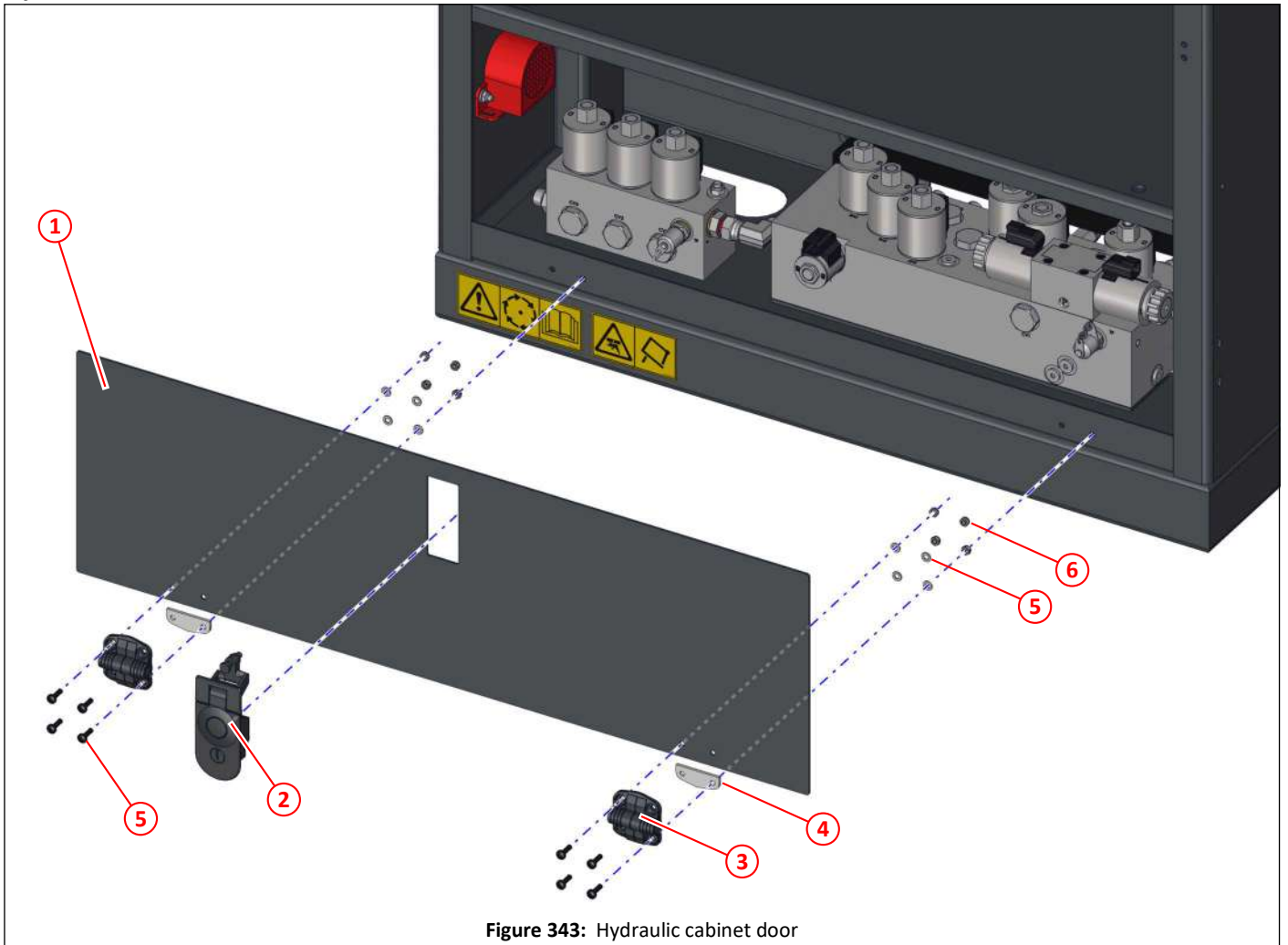

Figure 343: Hydraulic cabinet door

Item	Part No	Qty	Description
①	043078	1	Door, hydraulic cabinet
②	033634	1	Latch, sealed
③	027193	2	Hinge, door, plastic
④	028320	2	Packer, hinge
⑤	000234	8	Pan head Pozidrive setscrew M5 x 16, black
⑥	000410	8	Washer M5
⑦	000155	8	Nyloc nut M5

Main and options valve blocks mounting

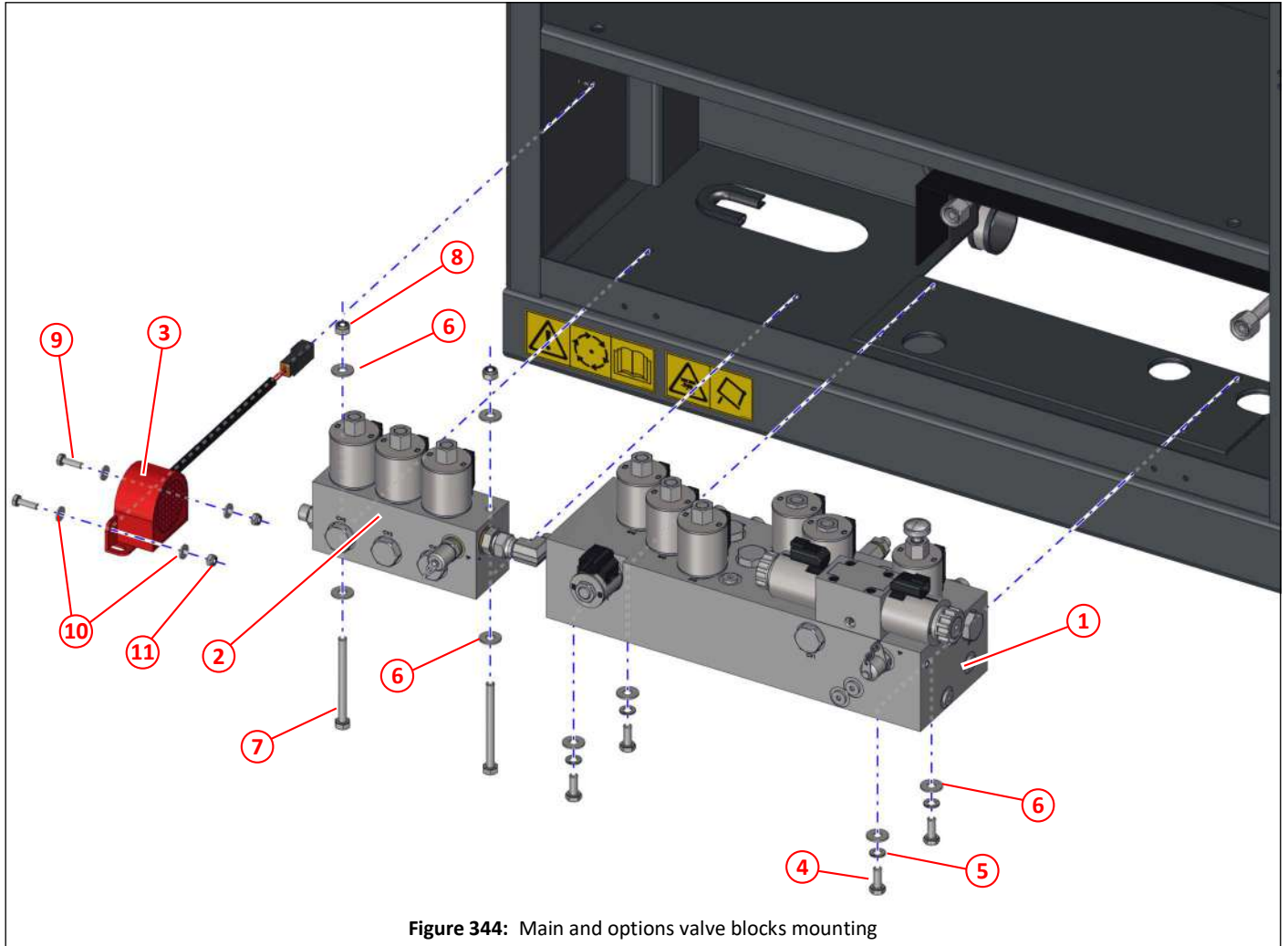

Figure 344: Main and options valve blocks mounting

Item	Part No	Qty	Description	
①		1	Main valve block	277
②		1	Options valve block	281
③	037666	1	Sounder, hopper/door operation, complete assembly	
④	011010	4	Setscrew HT M8 x20	
⑤	011093	4	Spring Washer M8	
⑥	011092	8	Washer M8	
⑦	011019	2	Bolt HT M8 x 90	
⑧	011073	2	Nyloc nut T M8	
⑨	011067	2	Setscrew HT M6 x 20	
⑩	011090	4	Washer M6	
⑪	011071	2	Nyloc nut T M6	

Lifting eyes

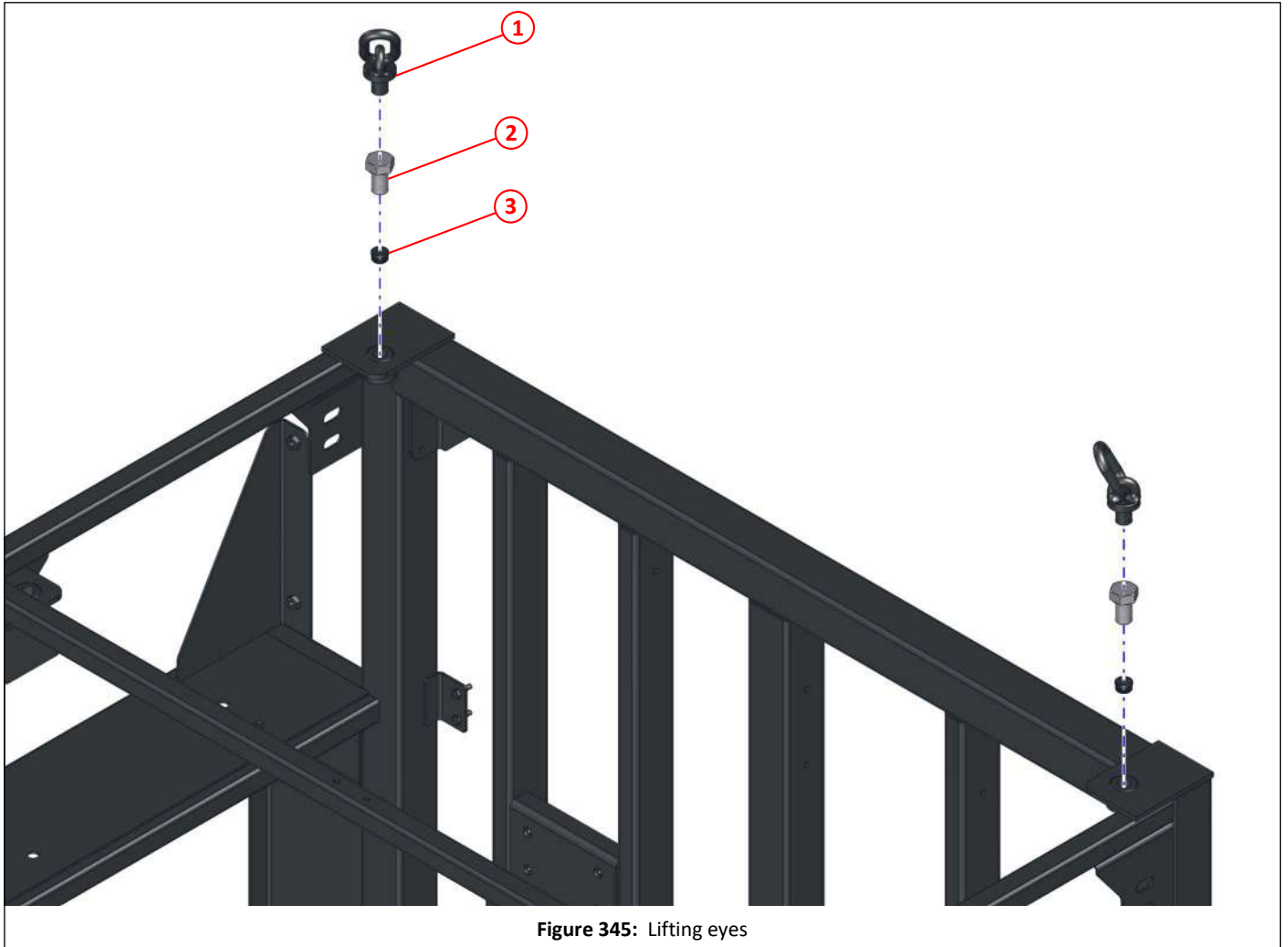

Figure 345: Lifting eyes

Item	Part No	Qty	Description	
①	035941	2	Linked eyebolt 1.6T	
②	000430	2	Screw M24 x 40, zinc plated	
③	026173	2	Plastic plug ø25.4 (black)	

Engine frame and ancillary parts

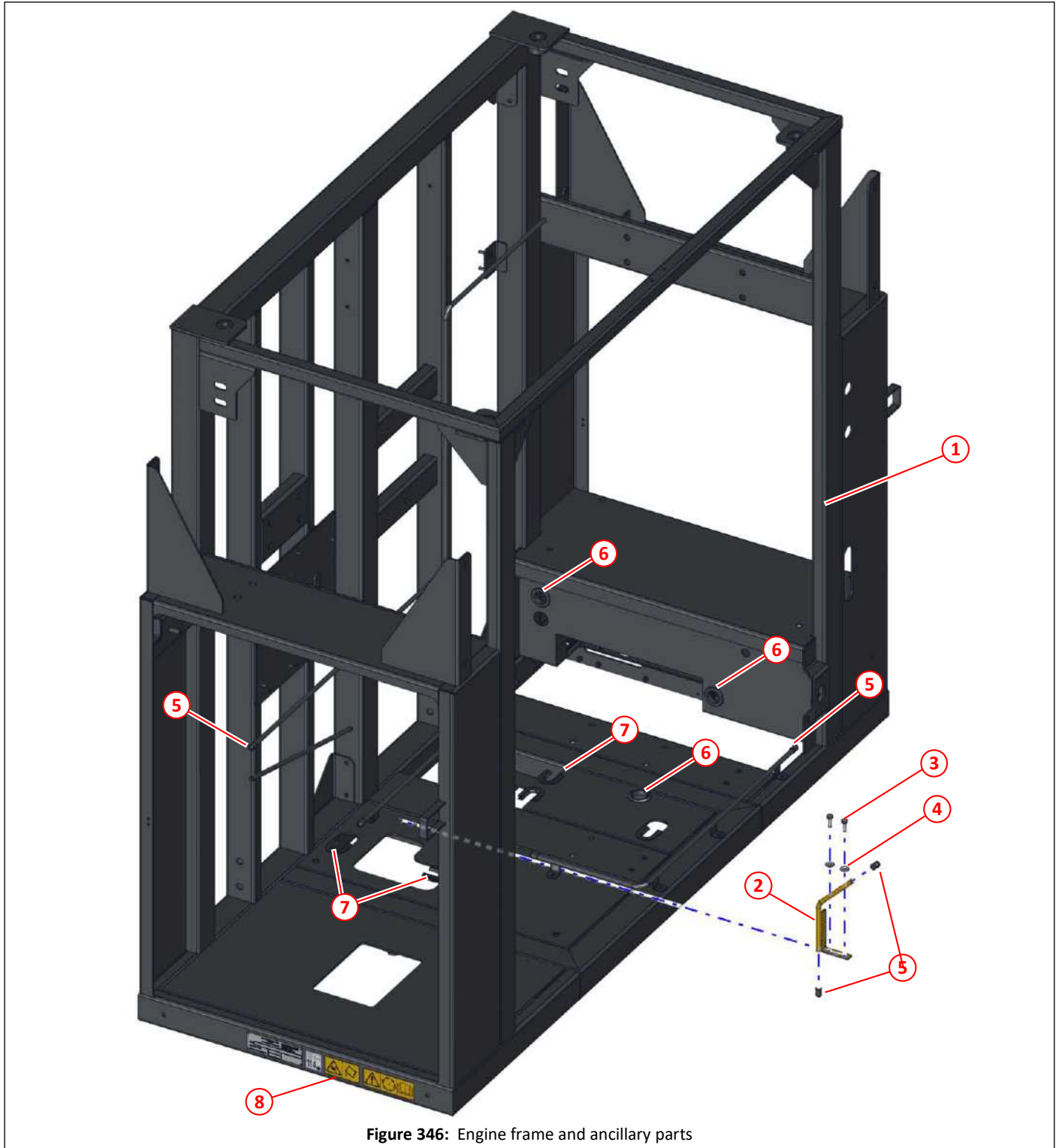

Figure 346: Engine frame and ancillary parts

Item	Part No	Qty	Description	
①	046932	1	Engine frame, front subframe	
②	046955	1	Lower loom rail 3	
③	011011	2	Setscrew HT M8 x 25	
④	011092	2	Washer M8	
⑤	043065	As req	Pipe cap $\phi 12$, various locations on engine frame	
⑥	022257	3	Grommet $\phi 40 \times \phi 50 \times 4$	
⑦	005073	As req	Safety edging, TITANFAST MET106, cut to length, various locations on engine frame	
⑧			Labels	432

Subframe

Engine frame and subframe general arrangement

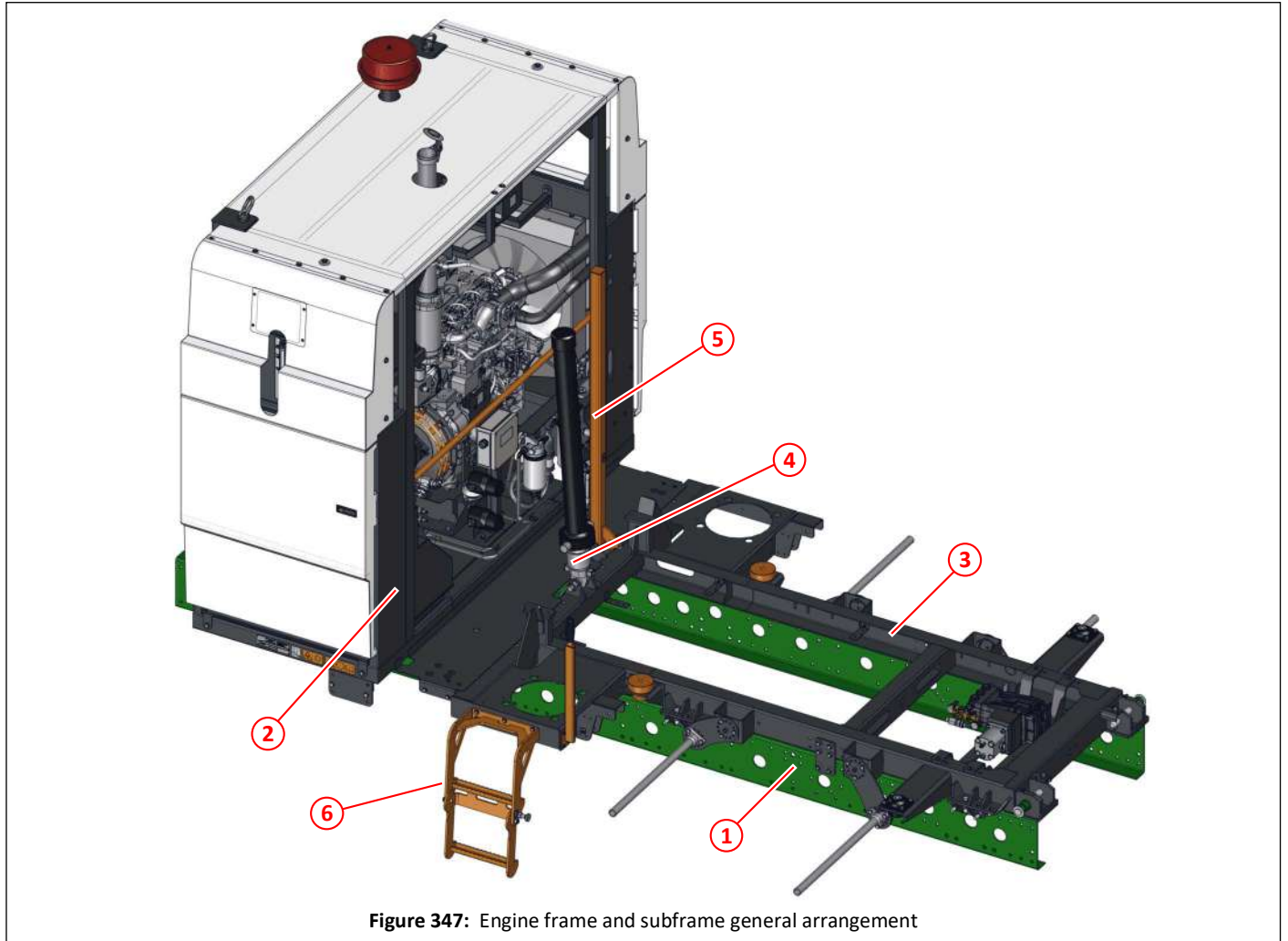

Figure 347: Engine frame and subframe general arrangement

Item	Part No	Qty	Description	
①			Chassis, shown for reference only	
②	046932	1	Engine frame, front subframe	382
③	042942	1	Subframe	398
④	024249	1	Ram, dual acting, hopper lift	169,288,392
⑤	047365	1	Hopper safety prop assembly	336
⑥	047083	1	Folding ladder assembly	390,391

Engine frame to subframe mounting

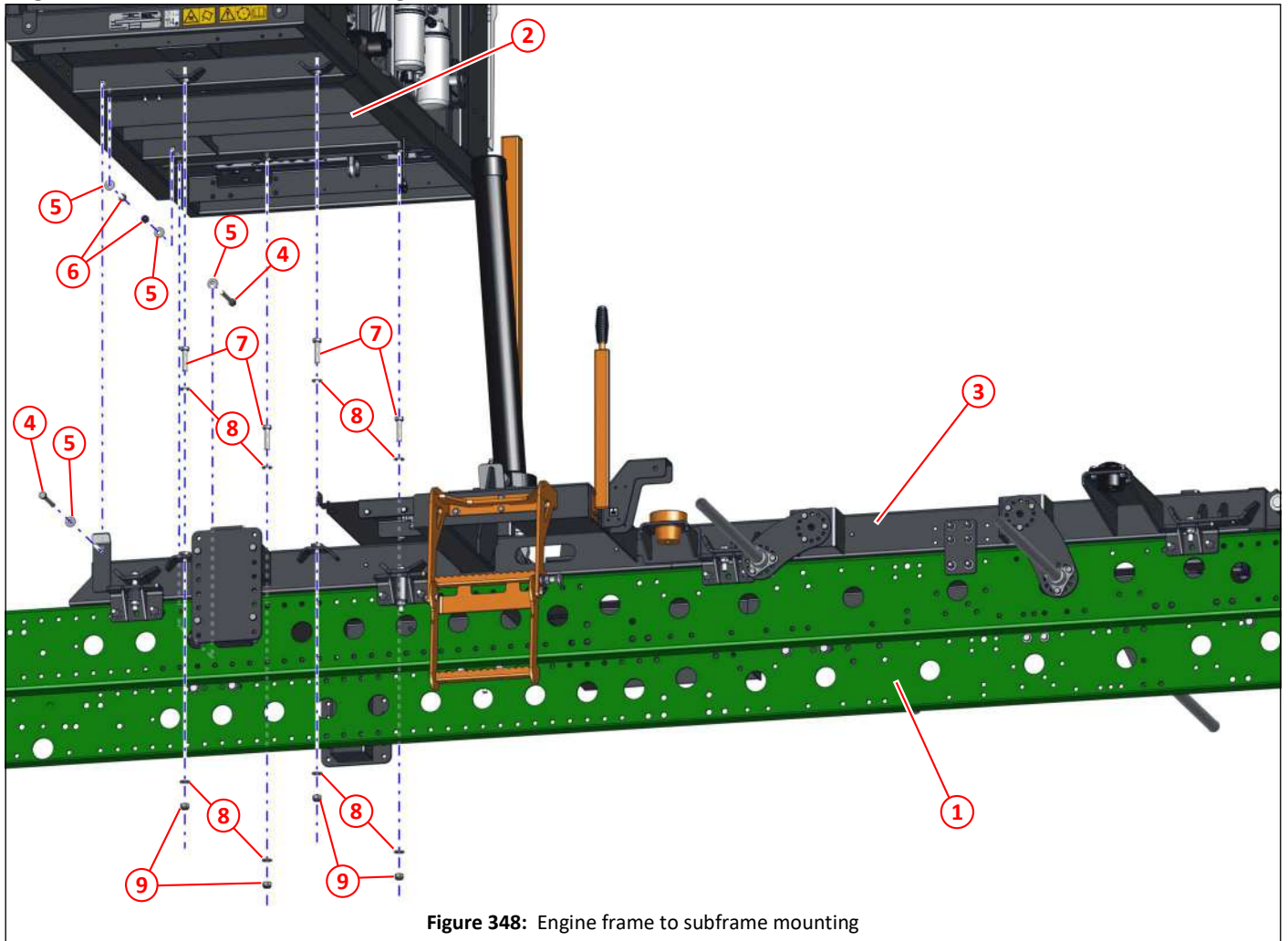

Figure 348: Engine frame to subframe mounting

Item	Part No	Qty	Description	
①			Chassis, shown for reference only	
②	046932	1	Engine frame, front subframe	
③	042942	1	Subframe	398
④	011064	2	Bolt HT M12 x 110	
⑤	011096	4	Washer M12	
⑥	011077	2	Nyloc nut T M12	
⑦	000204	4	Set bolt M14 x 60, grade 10.9	
⑧	000073	8	Washer M14	
⑨	000164	4	Nyloc nut M14, grade 10	

Subframe to chassis mounting general arrangement

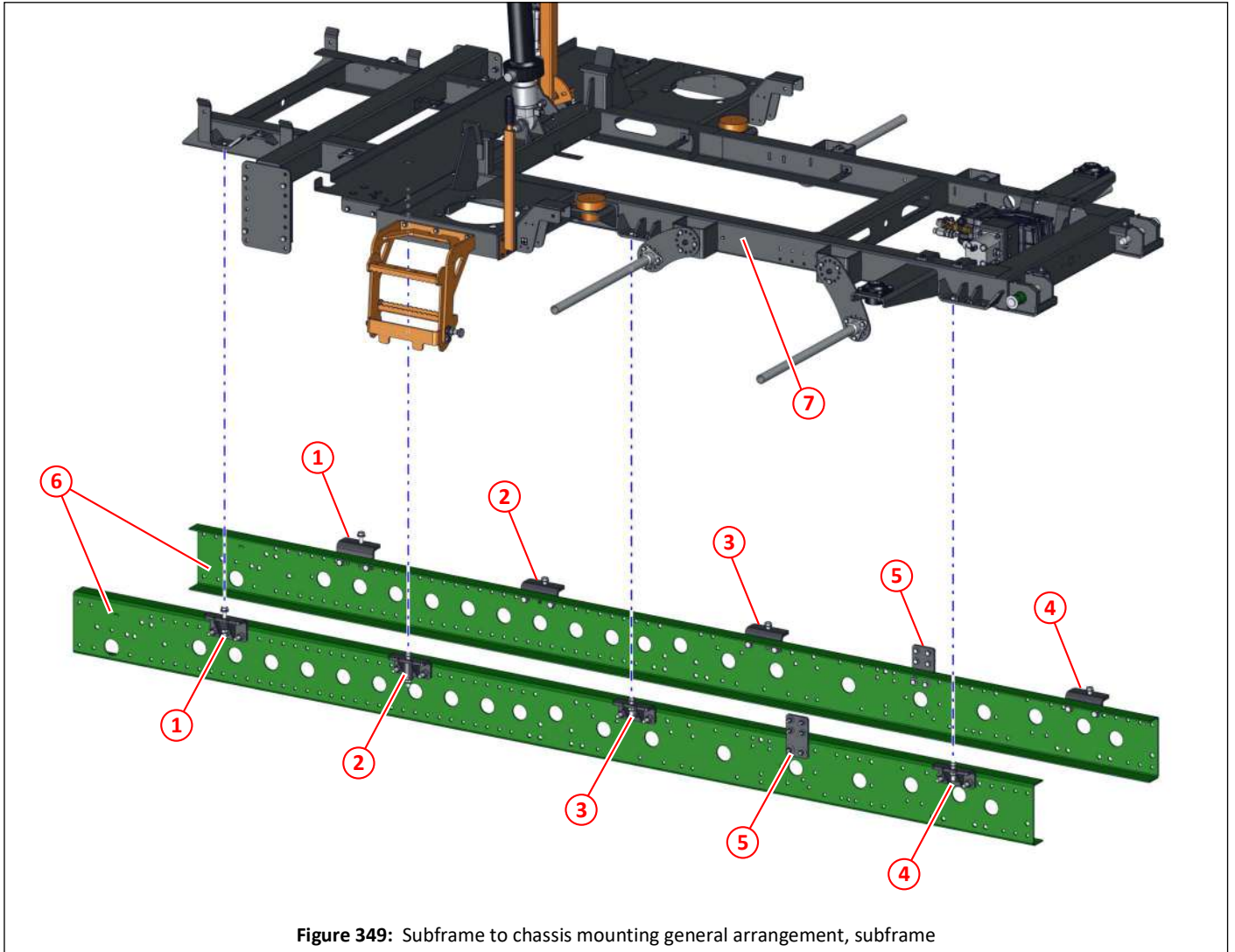

Figure 349: Subframe to chassis mounting general arrangement, subframe

Item	Part No	Qty	Description	
①			Chassis mounting bracket, position 1	386
②			Chassis mounting bracket, position 2	387
③			Chassis mounting bracket, position 3	388
④			Chassis mounting bracket, position 4	388
⑤			Chassis lateral support bracket	389
⑥			Chassis rails	
⑦			Subframe	398

i Universal chassis mounting bracket shown and fittings shown, actual bracket and fittings will depend on the vehicle chassis.

Brackets and fittings are available for specific vehicle chassis. Please contact the Scarab Parts Department with your vehicle details and works number.

Subframe to chassis mount, position 1

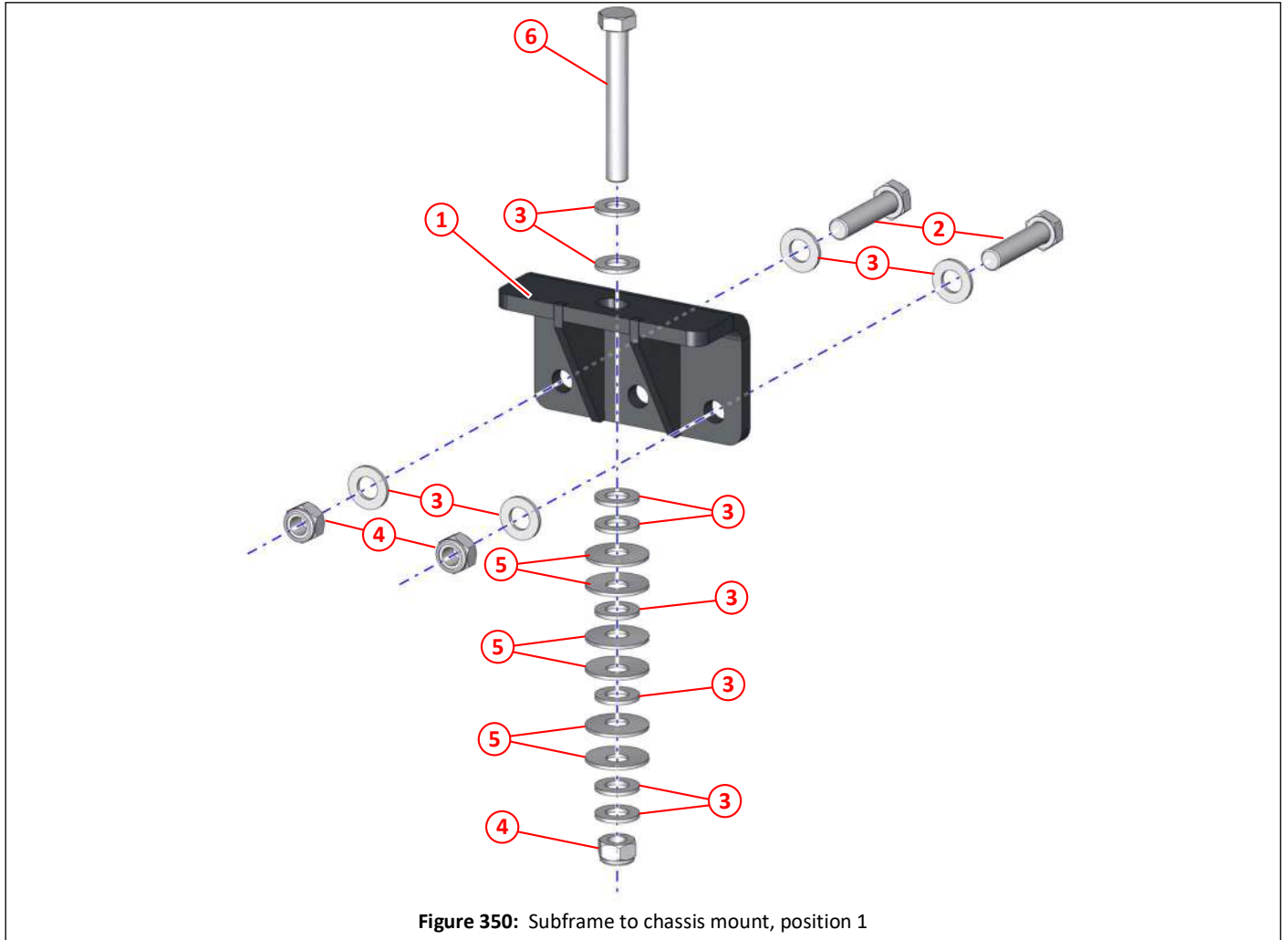

Figure 350: Subframe to chassis mount, position 1

Item	Part No	Qty	Description	
①	034907	1	Chassis mounting bracket, front	385
②	000204	2	Set bolt M14 x 60, grade 10.9	
③	000073	12	Washer M14	
④	000164	3	Nyloc nut T M14, grade 10	
⑤	036824	6	Disc spring	
⑥	000102	1	Bolt HT M14 x 100, grade 10.9	

i Universal chassis mounting bracket shown and fittings shown, actual bracket and fittings will depend on the vehicle chassis.

Brackets and fittings are available for specific vehicle chassis. Please contact the Scarab Parts Department with your vehicle details and works number.

Subframe to chassis mount, position 2

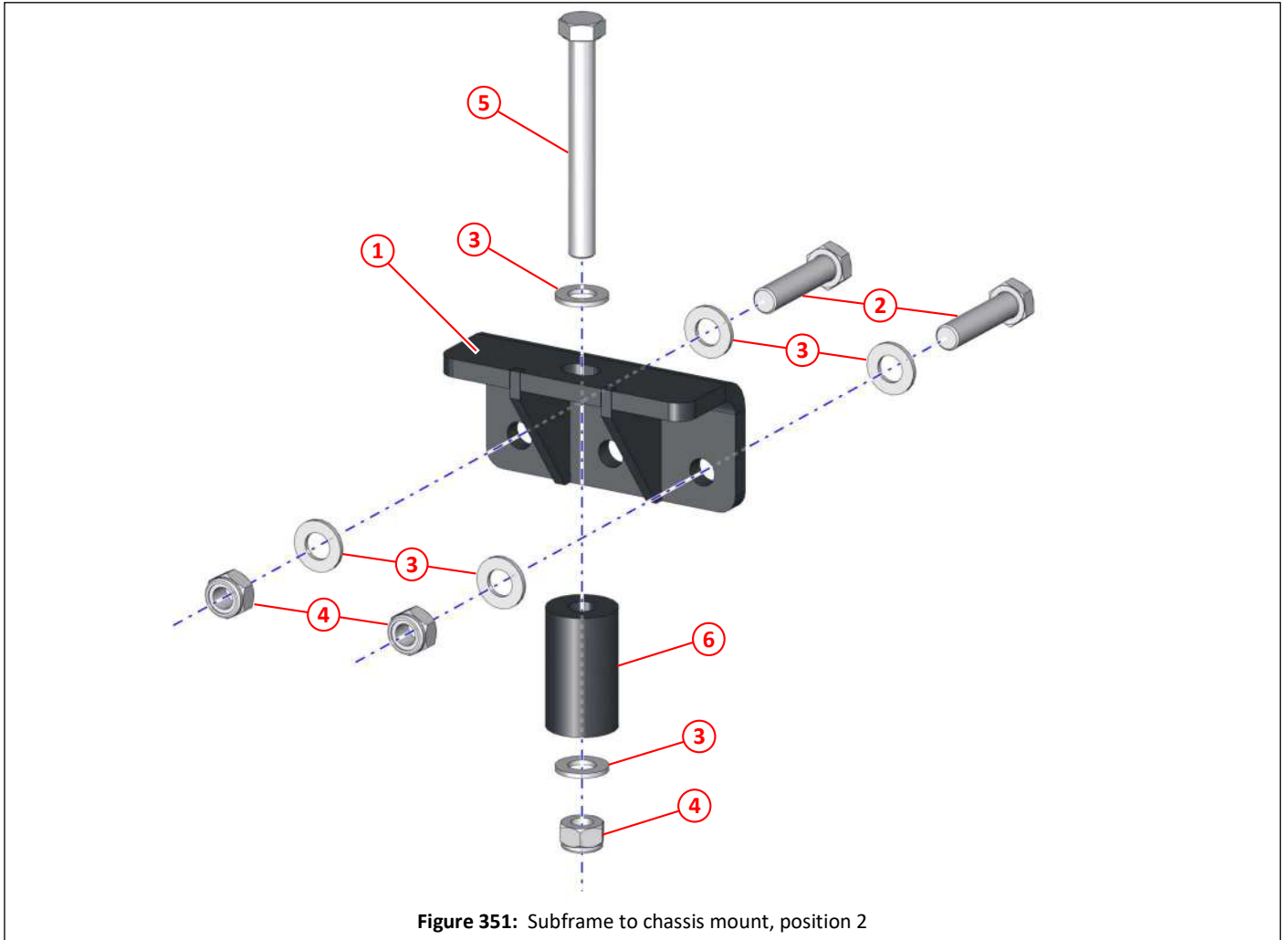

Figure 351: Subframe to chassis mount, position 2

Item	Part No	Qty	Description
①	034384	1	Chassis mounting bracket
②	000204	2	Set bolt M14 x 60, grade 10.9
③	000073	6	Washer M14
④	000164	3	Nyloc nut T M14, grade 10
⑤	000163	1	Bolt HT M14 x 120, grade 10.9
⑥	034909	1	Spacer $\varnothing 15 \times \varnothing 38 \times 65$

i Universal chassis mounting bracket shown and fittings shown, actual bracket and fittings will depend on the vehicle chassis.

Brackets and fittings are available for specific vehicle chassis. Please contact the Scarab Parts Department with your vehicle details and works number.

Subframe to chassis mount, position 3 and 4

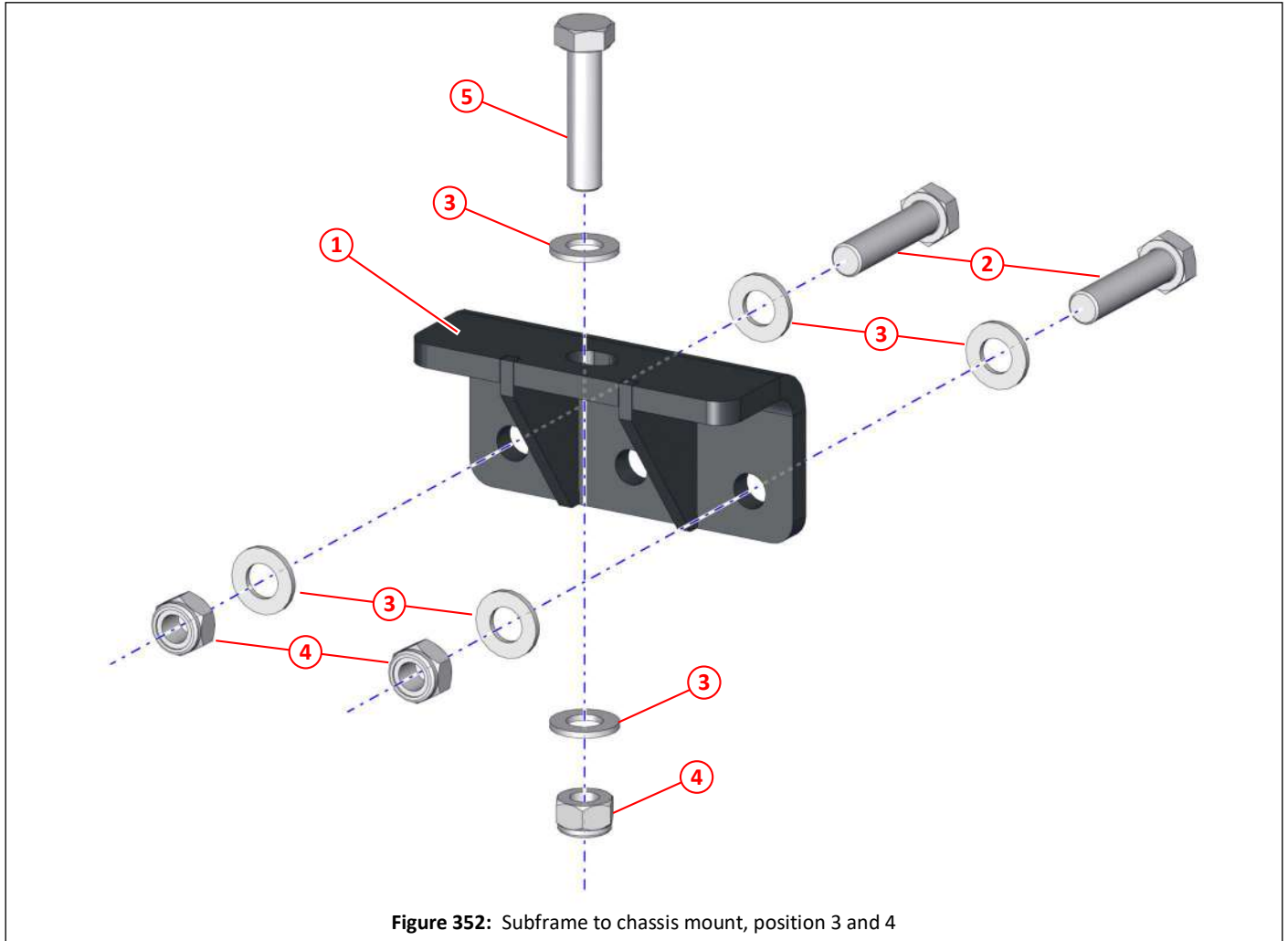

Figure 352: Subframe to chassis mount, position 3 and 4

Item	Part No	Qty	Description
①	034384	1	Chassis mounting bracket
②	000204	2	Set bolt M14 x 60, grade 10.9
③	000073	6	Washer M14
④	000164	3	Nyloc nut T M14, grade 10
⑤	000163	1	Bolt HT M14 x 120, grade 10.9

i Universal chassis mounting bracket shown and fittings shown, actual bracket and fittings will depend on the vehicle chassis.
 Brackets and fittings are available for specific vehicle chassis. Please contact the Scarab Parts Department with your vehicle details and works number.

Subframe to chassis lateral support

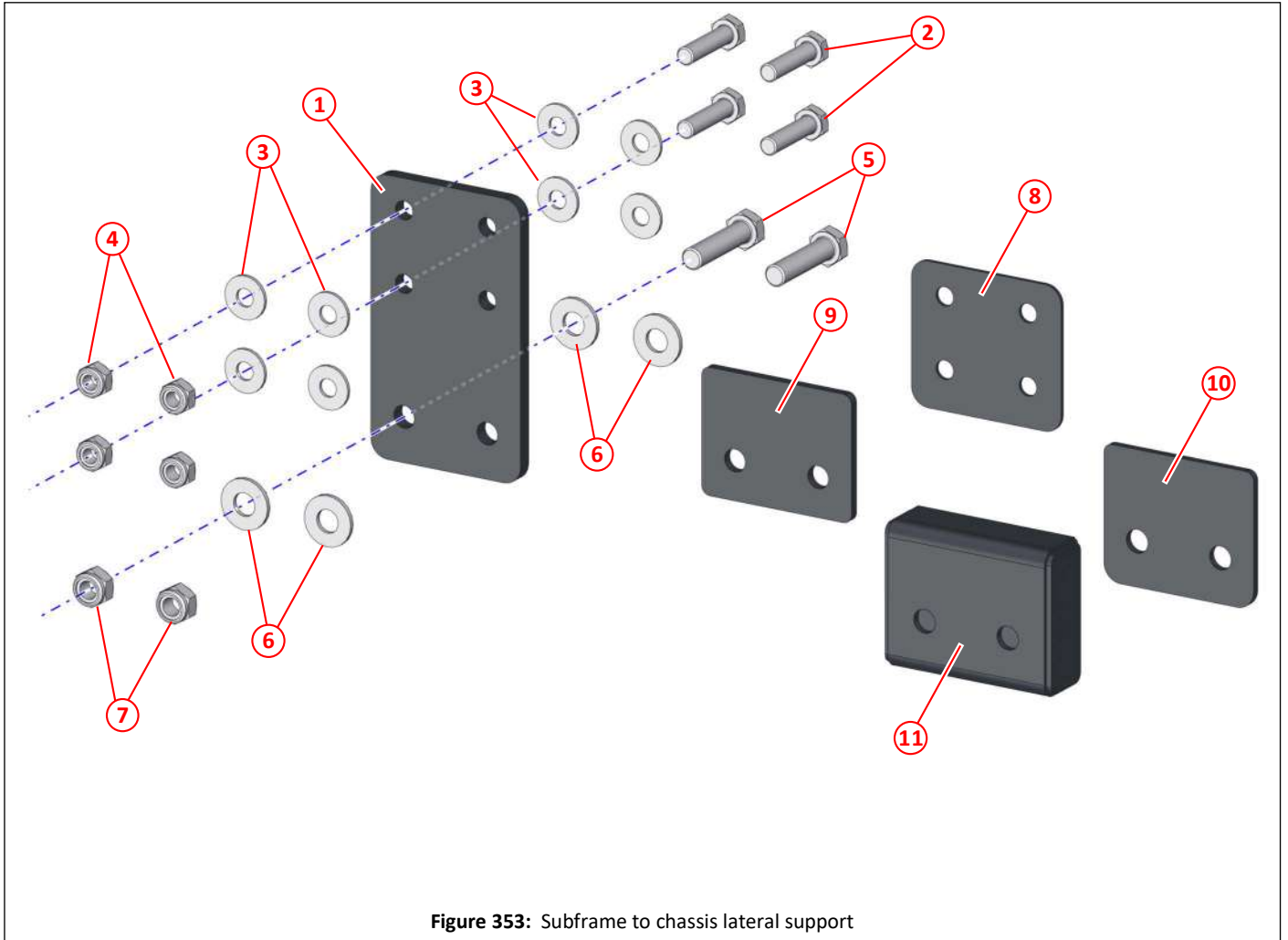

Figure 353: Subframe to chassis lateral support

Item	Part No	Qty	Description
①	040356	1	Lateral support bracket, rear
②	011034	4	Setscrew M10 x 40
③	011094	8	Washer M10
④	011075	4	Nyloc nut T M10
⑤	000024	2	Setscrew HT M12 x 50
⑥	011096	4	Washer M12
⑦	011077	2	Nyloc Nut T M12
Packers			
⑧	041309	1	Subframe lateral support packer
⑨	034387	1	Packer Type B
⑩	045200	1	Lateral support packer
⑪	038140	1	Subframe packer lateral

i Universal chassis mounting bracket shown and fittings shown, actual bracket and fittings will depend on the vehicle chassis.

Brackets and fittings are available for specific vehicle chassis. Please contact the Scarab Parts Department with your vehicle details and works number.

Folding ladder and grab handle mounting

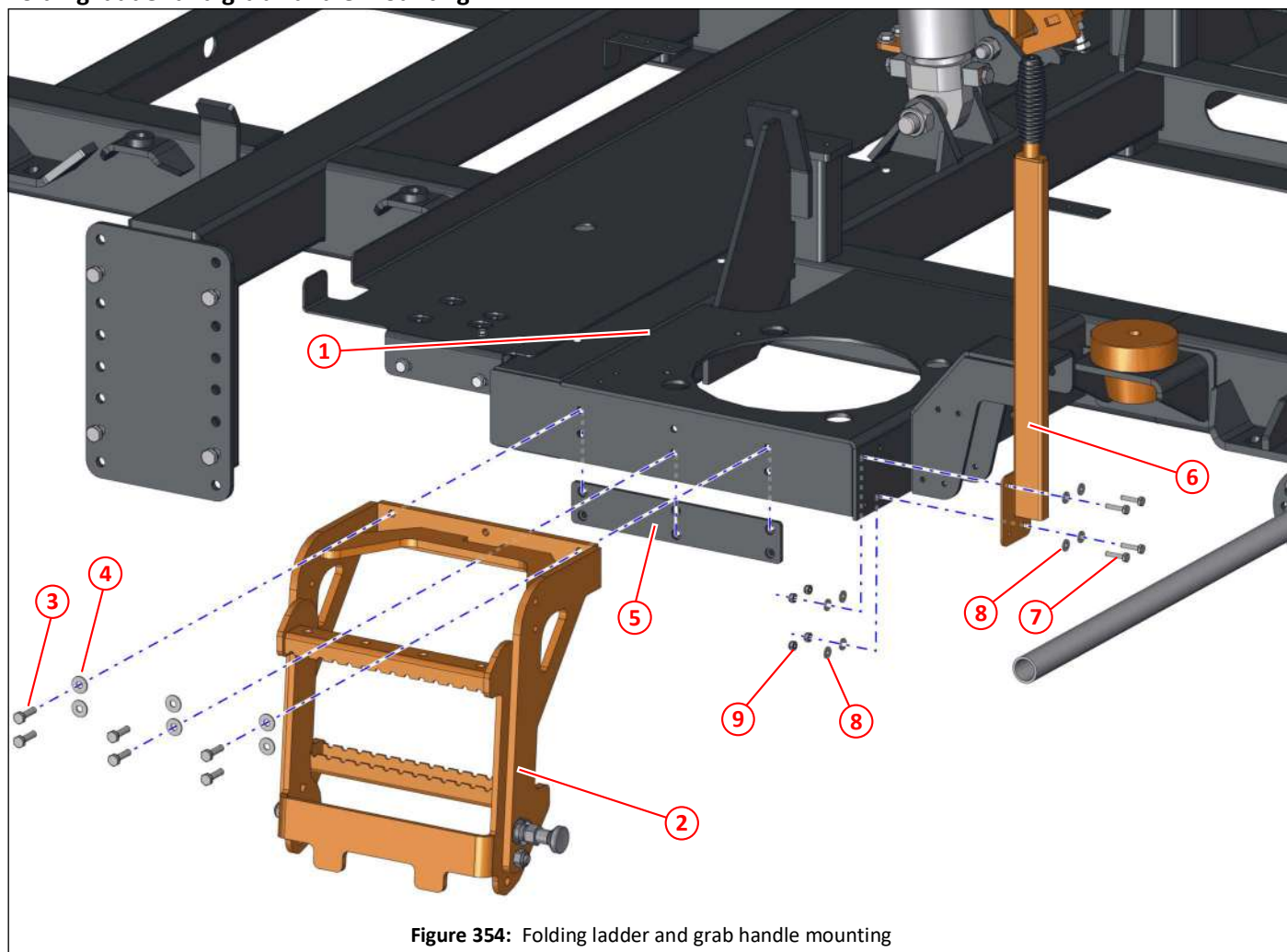

Figure 354: Folding ladder and grab handle mounting

Item	Part No	Qty	Description	
①	042942	1	Subframe	398
②	047083	1	Folding ladder assembly	391
③	011012	6	Setscrew HT M8 x 30	
④	011092	6	Washer M8	
⑤	047086	1	Ladder mount stiffener	
⑥	043608	1	Grab handle	391
⑦	011087	4	Setscrew M6 x 25	
⑧	011090	8	Washer M6	
⑨	011071	4	Nyloc nut T M6	

Folding ladder and grab handle

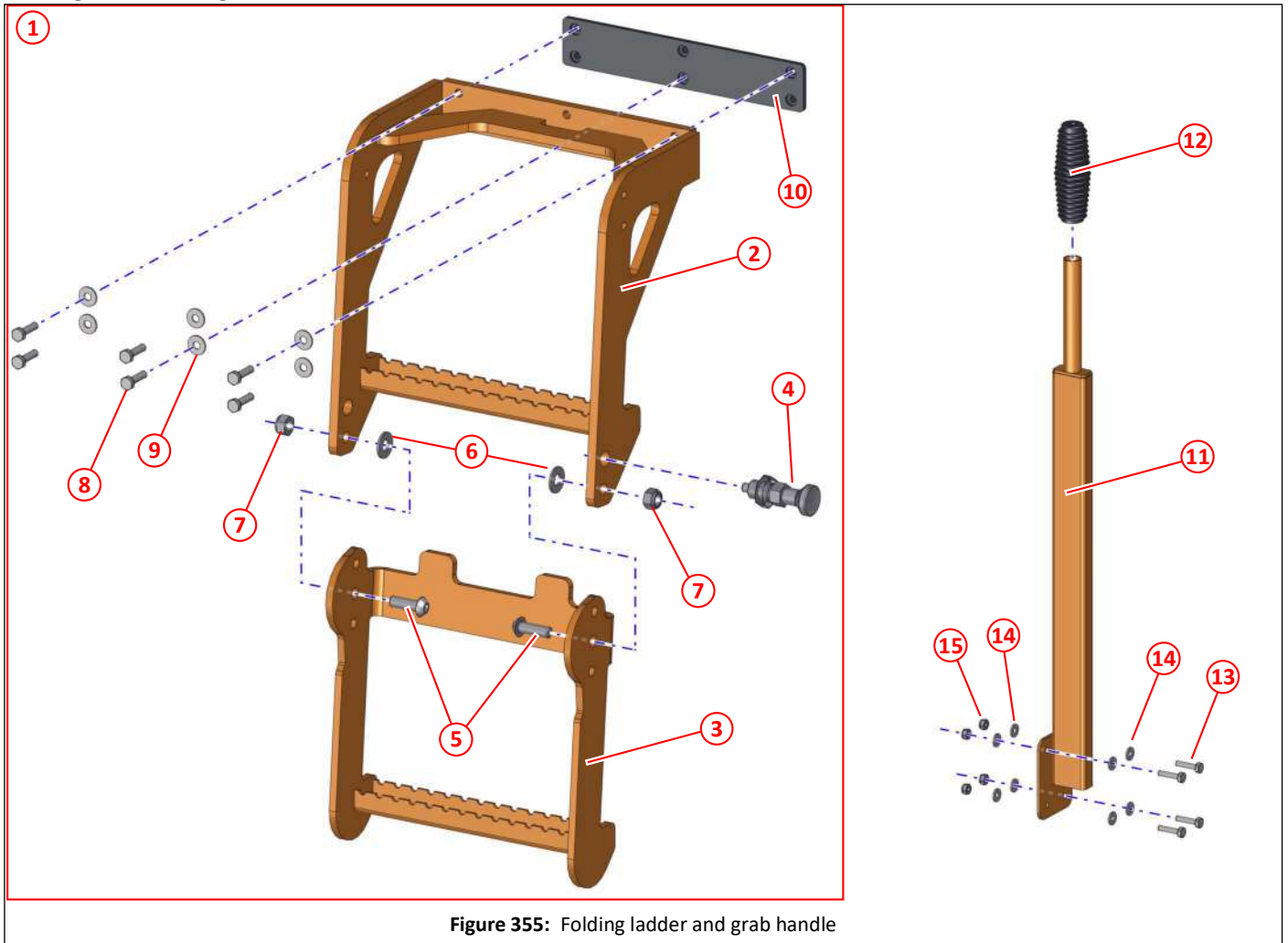

Figure 355: Folding ladder and grab handle

Item	Part No	Qty	Description
①	047083	1	Folding ladder assembly
②	048166	1	Folding ladder, upper
③	048167	1	Folding ladder, lower
④	048168	1	Spring loaded plunger ø10 pin, stainless steel
⑤	000445	2	Socket button head screw M12 x 35, stainless steel
⑥	000277	2	Washer M12, stainless steel
⑦	000275	2	Nyloc nut T M12, stainless steel
⑧	011012	6	Setscrew HT M8 x 30
⑨	011092	6	Washer M8
⑩	047086	1	Ladder mount stiffener
⑪	043608	1	Grab handle
⑫	039680	1	Handle grip
⑬	011087	4	Setscrew M6 x 25
⑭	011090	8	Washer M6
⑮	011071	4	Nyloc nut T M6

Hopper lift ram subframe mounting

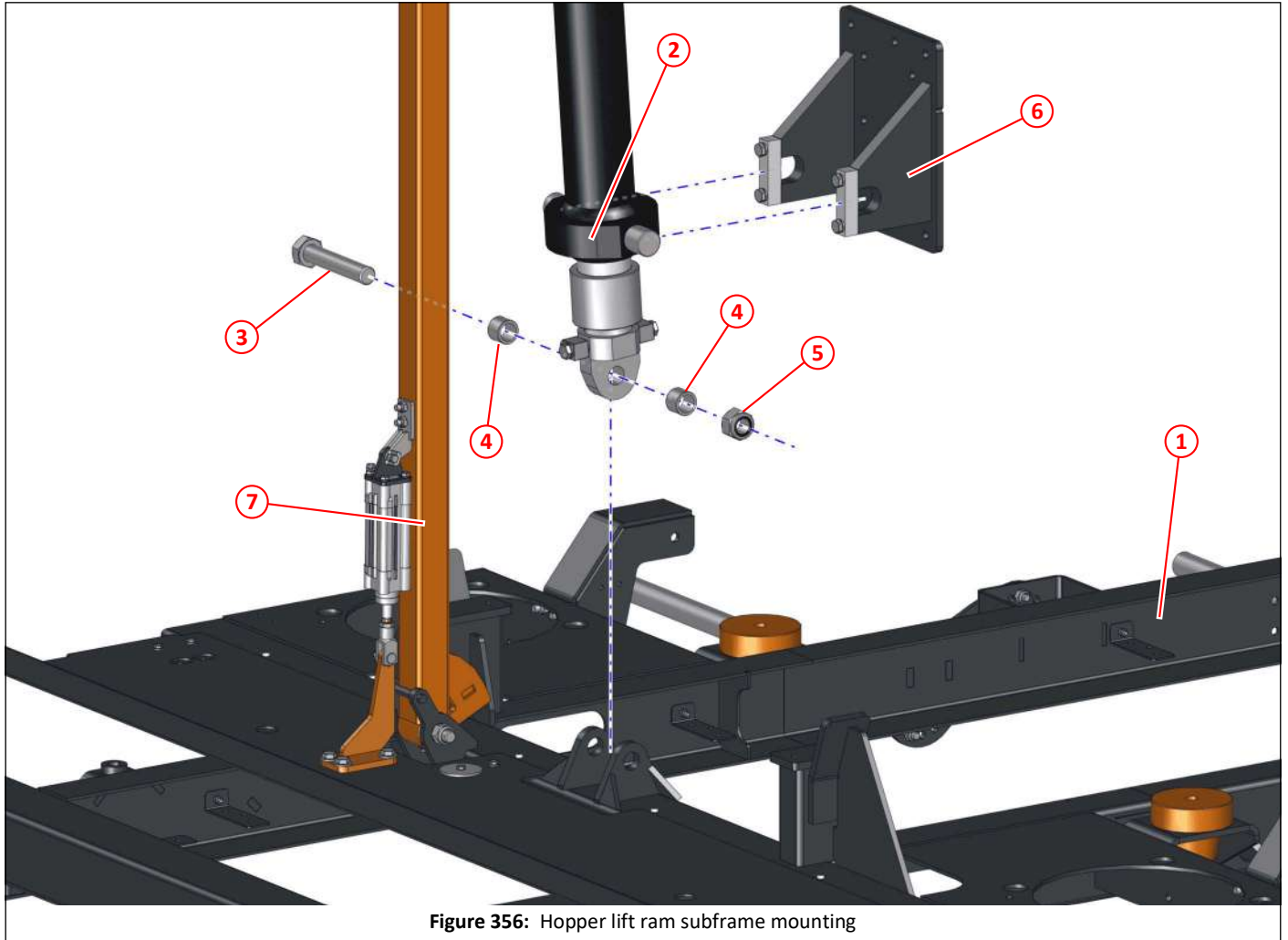

Figure 356: Hopper lift ram subframe mounting

Item	Part No	Qty	Description	
①	042942	1	Subframe	398
②	024249	1	Ram, dual acting, hopper lift	169,288,383
③	000241	1	Bolt HT M24 x 130	
④	013714	2	Spacer, ram	
⑤	000008	1	Nyloc nut T M24	
⑥	010719	1	Pivot, hopper lift ram	169
⑦	047365	1	Hopper safety prop assembly	336

Hopper safety prop subframe mounting

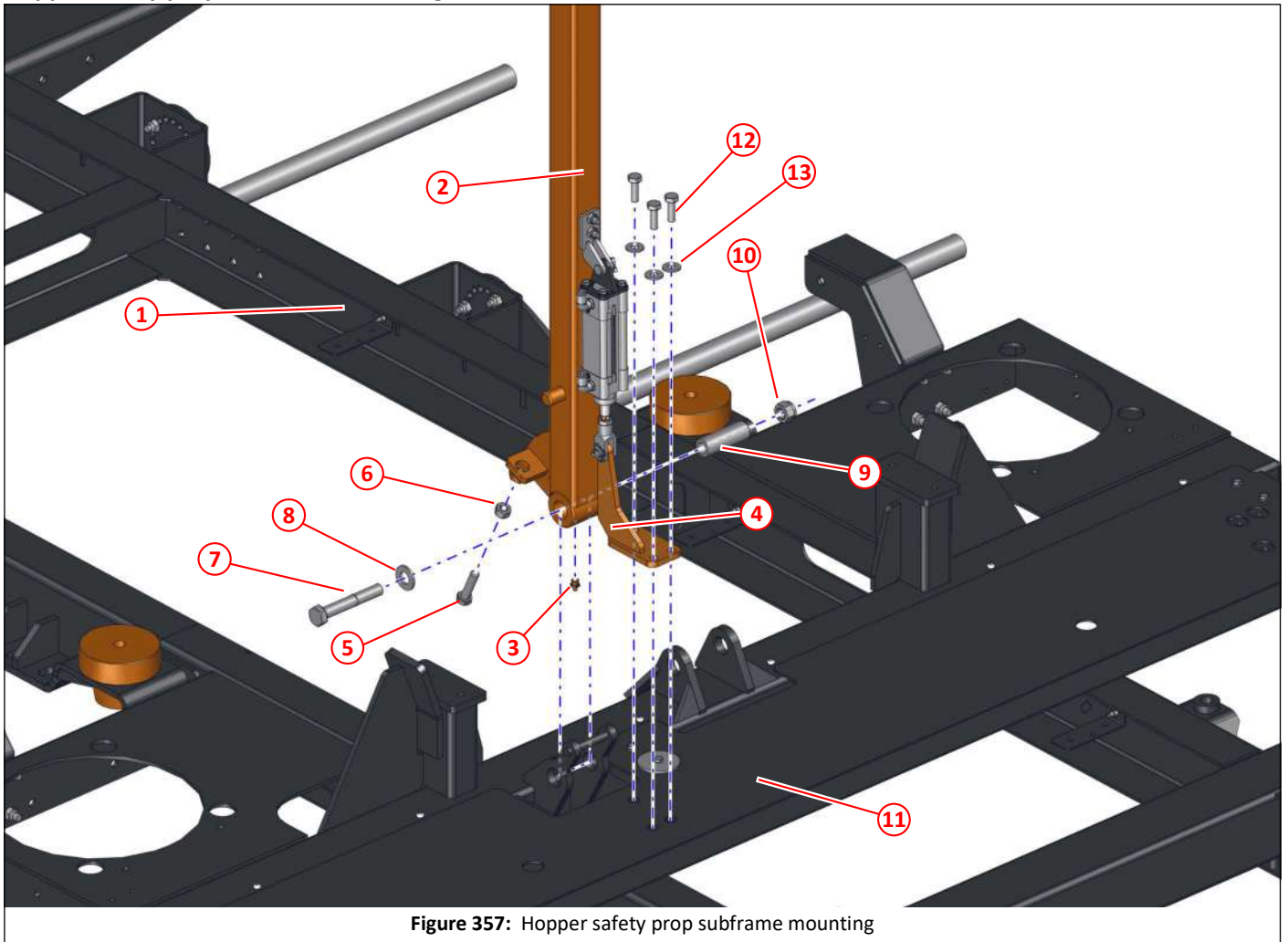

Figure 357: Hopper safety prop subframe mounting

Item	Part No	Qty	Description	
①	042942	1	Subframe	398
②	043391	1	Hopper safety prop	336
③	010903	1	Grease nipple, straight, 1/8" BSP	
④	047357	1	Prop kicker floor mount	336
⑤	011054	1	Setscrew HT M12 x 45	
⑥	011076	1	Full nut M12	
⑦	011133	1	Bolt HT M16 x 100	
⑧	011135	1	Washer M16	
⑨	036240	1	Hopper prop spacer	
⑩	011060	1	Nyloc nut T M16	
⑪	047237	1	Floor plate	394
⑫	011032	3	Setscrew HT M10 x 30	
⑬	011094	3	Washer M10	

Floor plate

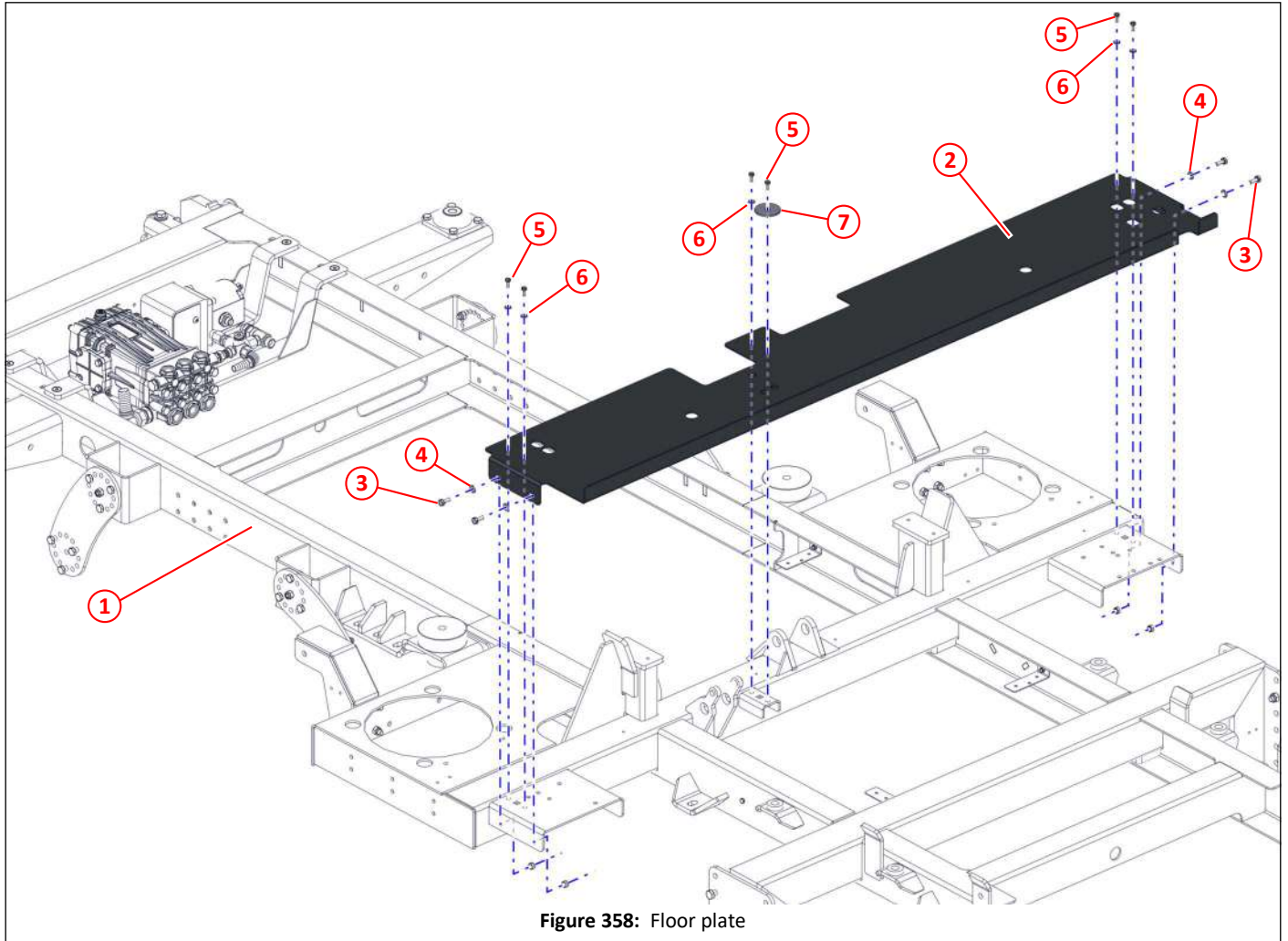

Figure 358: Floor plate

Item	Part No	Qty	Description	
①	042942	1	Subframe	398
②	047237	1	Floor plate	393
③	000256	4	Setscrew M8 x 20, stainless steel	
④	000419	4	Washer M8 ø17	
⑤	000250	6	Setscrew M6 x 16, stainless steel	
⑥	000254	5	Washer M6, stainless steel	
⑦	037064	1	Lock washer	

Nozzle lift cylinder mounting bracket

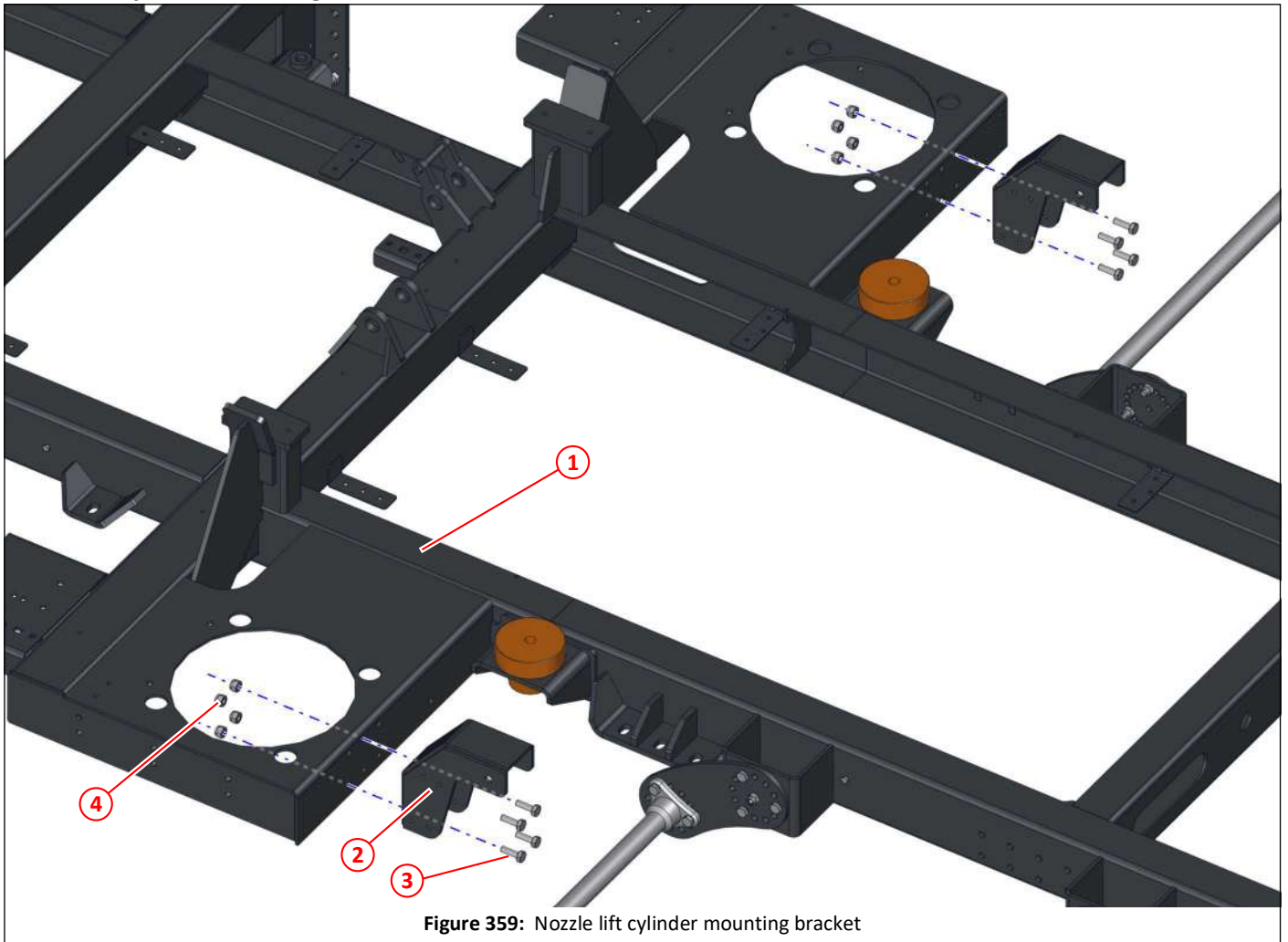
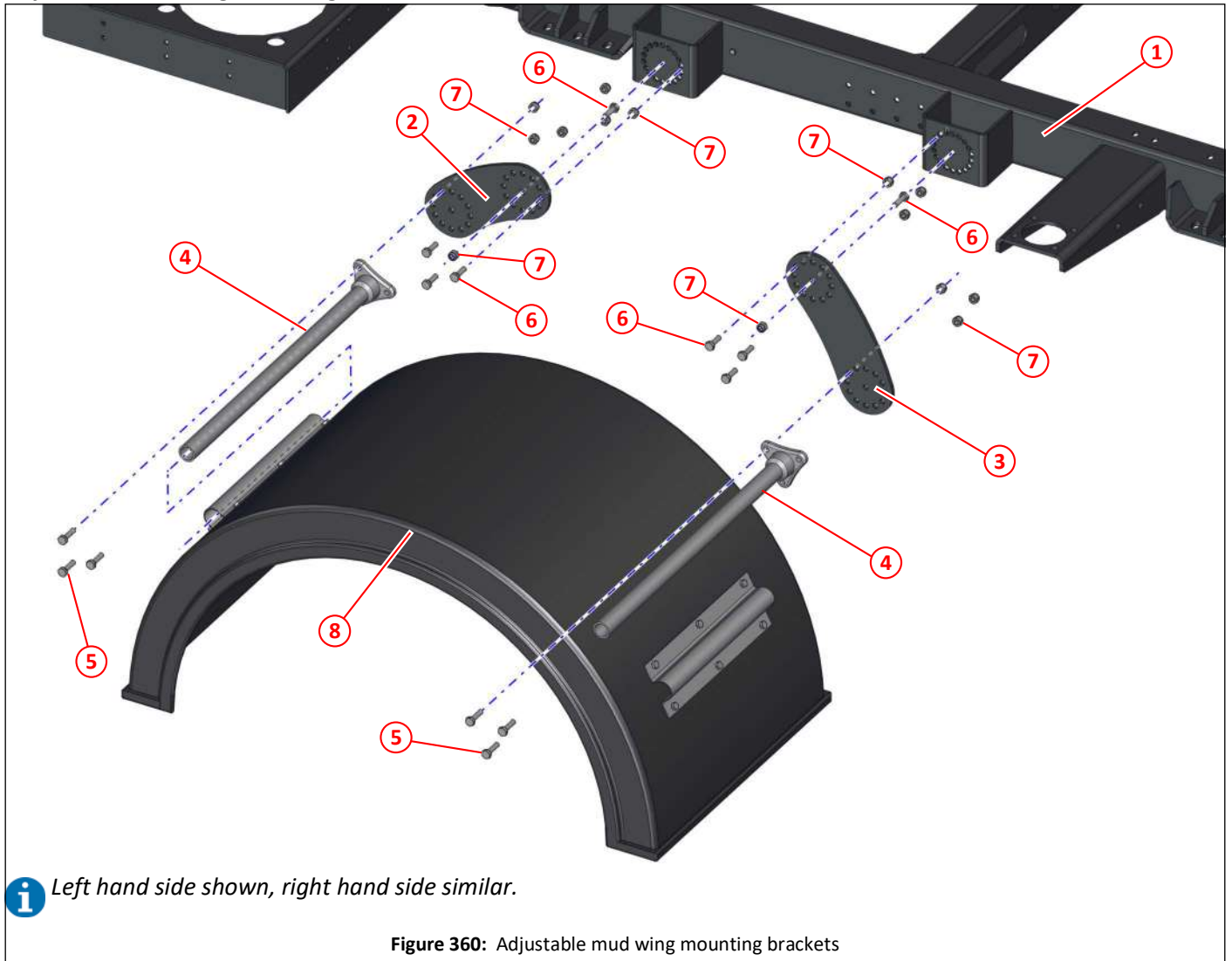

Figure 359: Nozzle lift cylinder mounting bracket

Item	Part No	Qty	Description	
①	042942	1	Subframe	398
②	030775	1	Cylinder mounting bracket, nozzle lift	
③	011032	4	Setscrew M10 x 30	
④	011075		Nyloc nut T M10	

i Quantities shown are for one bracket.

Adjustable mud wing mounting brackets



Item	Part No	Qty	Description	
①	042942	1	Subframe	398
②	047370 *	1	Mud wing offset plate, short	
③	047151 *	1	Mud wing offset plate, long	
④	013403	2	Stay, mud wing	
⑤	011033	6	Setscrew HT M10 x 35	
⑥	011032	8	Setscrew HT M10 x 30	
⑦	011075	14	Nyloc nut T M10	
⑧	021945	1	Mud wing / mudguard	397

*. Which mud wing offset plates are used will depend on the vehicle chassis, both types are shown above.

Mud wings / mudguards

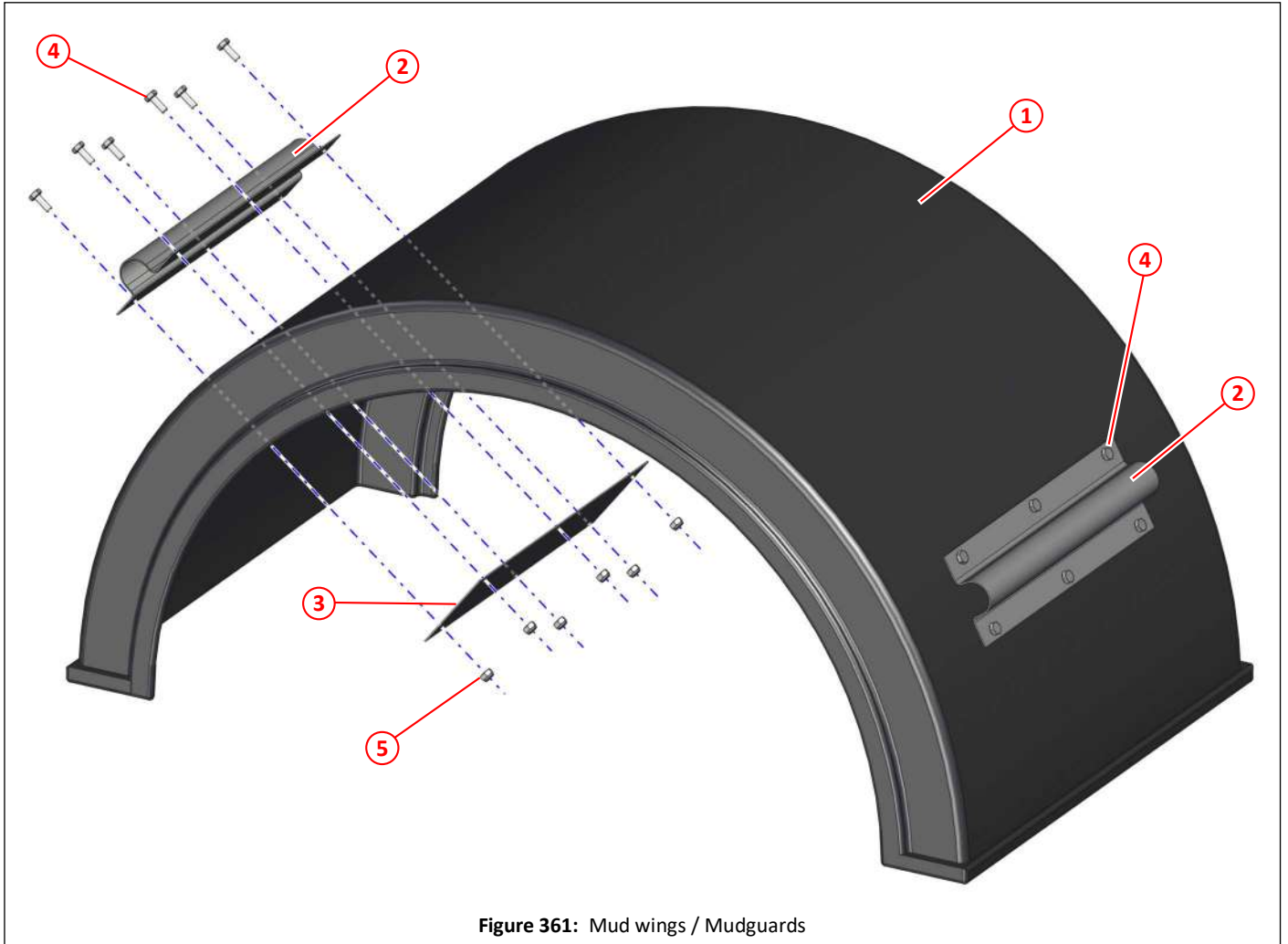

Figure 361: Mud wings / Mudguards

Item	Part No	Qty	Description	
①	021945	1	Mud wing / mudguard	396
②	013404	2	Bracket, mud wing / mudguard	
③	012954	2	Backplate, mud wing / mudguard bracket	
④	011010	12	Setscrew HT M8 x 20	
⑤	011073	12	Nyloc nut T M8	

Subframe and cable clip brackets

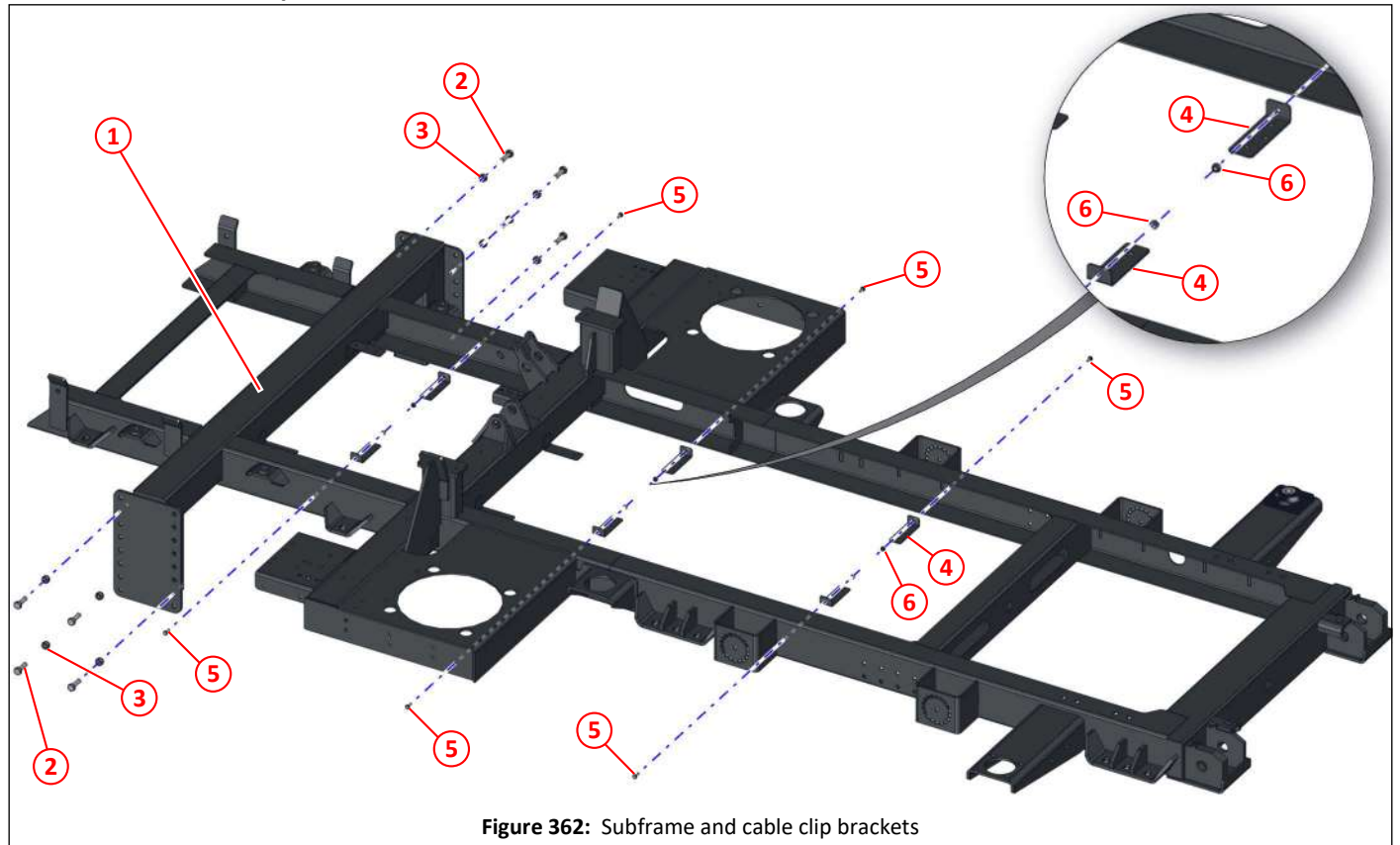

Figure 362: Subframe and cable clip brackets

Item	Part No	Qty	Description
①	042942	1	Subframe
②	011053	8	Setscrew HT M12 x 35
③	011077	8	Nyloc nut T M12
④	028862	6	Bracket, cable clip mounting
⑤	011001	6	Setscrew HT M6 x 16
⑥	011071	6	Nyloc nut T M6

Engine

<i>Description</i>	<i>Page</i>
Engine arrangement	400
Engine cradles	401
Engine mounts	402
Cooling fan and water pump	403
Ancillary belt, tensioner, alternator and engine speed sensors	404
Starter motor	405
Rail pressure sensor, charge air pressure and temp sensor	406
Coolant temperature sensor	407
Lube oil pressure sensor	408
Injectors and glow plugs	409
Engine, ECU, EAT, and sump drain	410
Fuel pump and filters	411
Exhaust stack	412
Air intake stack, lower	413
Air intake stack, upper	414
Coolant expansion tank	415
Combined oil/intercooler/radiator cooler	416
Centaflex coupling and fan pump housing plate	417
Service kits	418

Engine arrangement

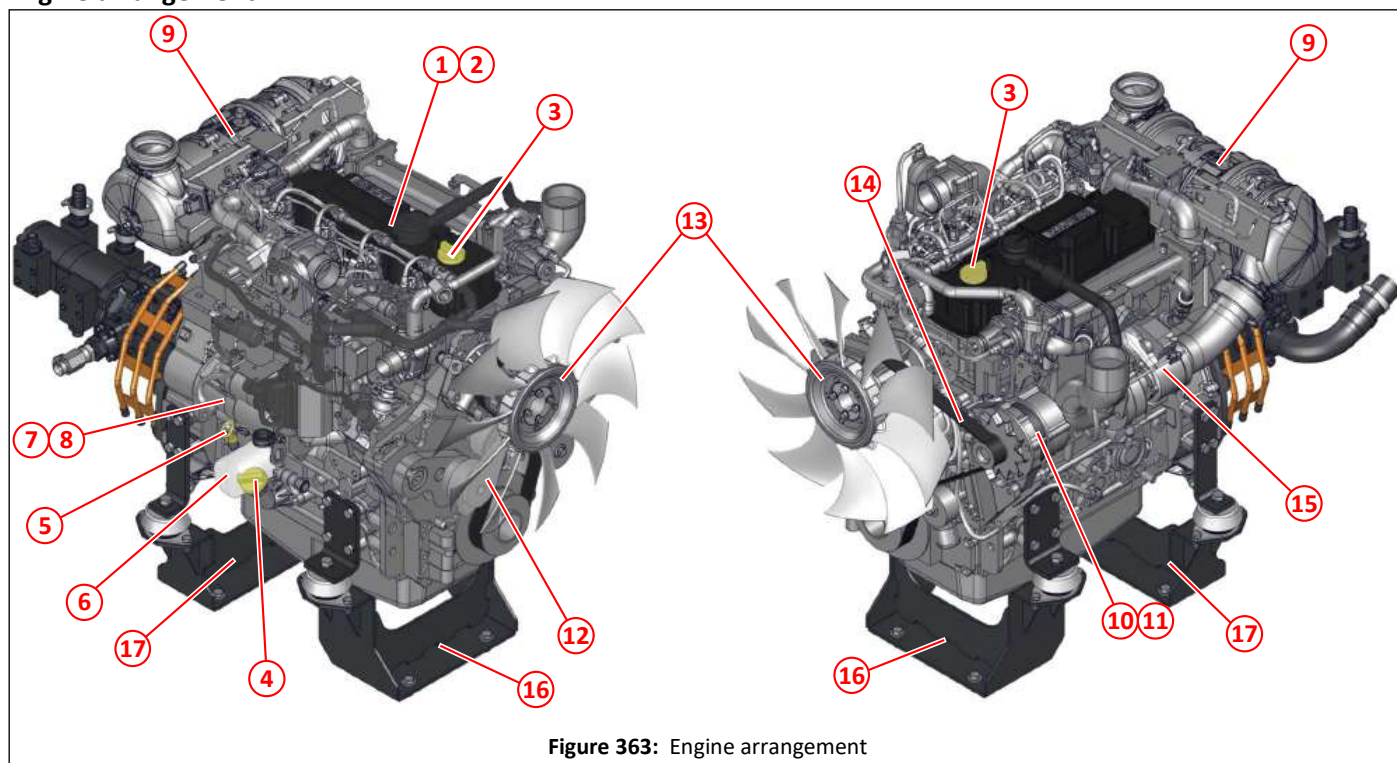

Figure 363: Engine arrangement

Item	Part No	Qty	Description
①	047624	1	DEUTZ 3.6 engine (Stage V) 12V
②	046169	1	DEUTZ 3.6 engine (Stage V) 24V
③	043781	1	Filler cap lube oil, top
④	043781	1	Filler cap lube oil, side
⑤	043222	1	Lube oil level dipstick
⑥	042232	1	Lube oil filter
⑦	044516	1	Starter motor 12V
⑧	043795	1	Starter motor 24V
⑨	045980	1	DEUTZ EAT
⑩	044517	1	Alternator 14V 95A 3.6L4 DEUTZ
⑪	043816	1	Alternator 28V 55A 3.6L4 DEUTZ
⑫	043815	1	Tensioner, V ribbed belt
⑬	043161	1	Fan and hub kit
⑭	043789	1	V ribbed belt 3.6L4 DEUTZ
⑮	047356	1	DEUTZ Turbo
⑯	042809	1	Engine cradle, front
⑰	042810	1	Engine cradle, rear

Engine cradles

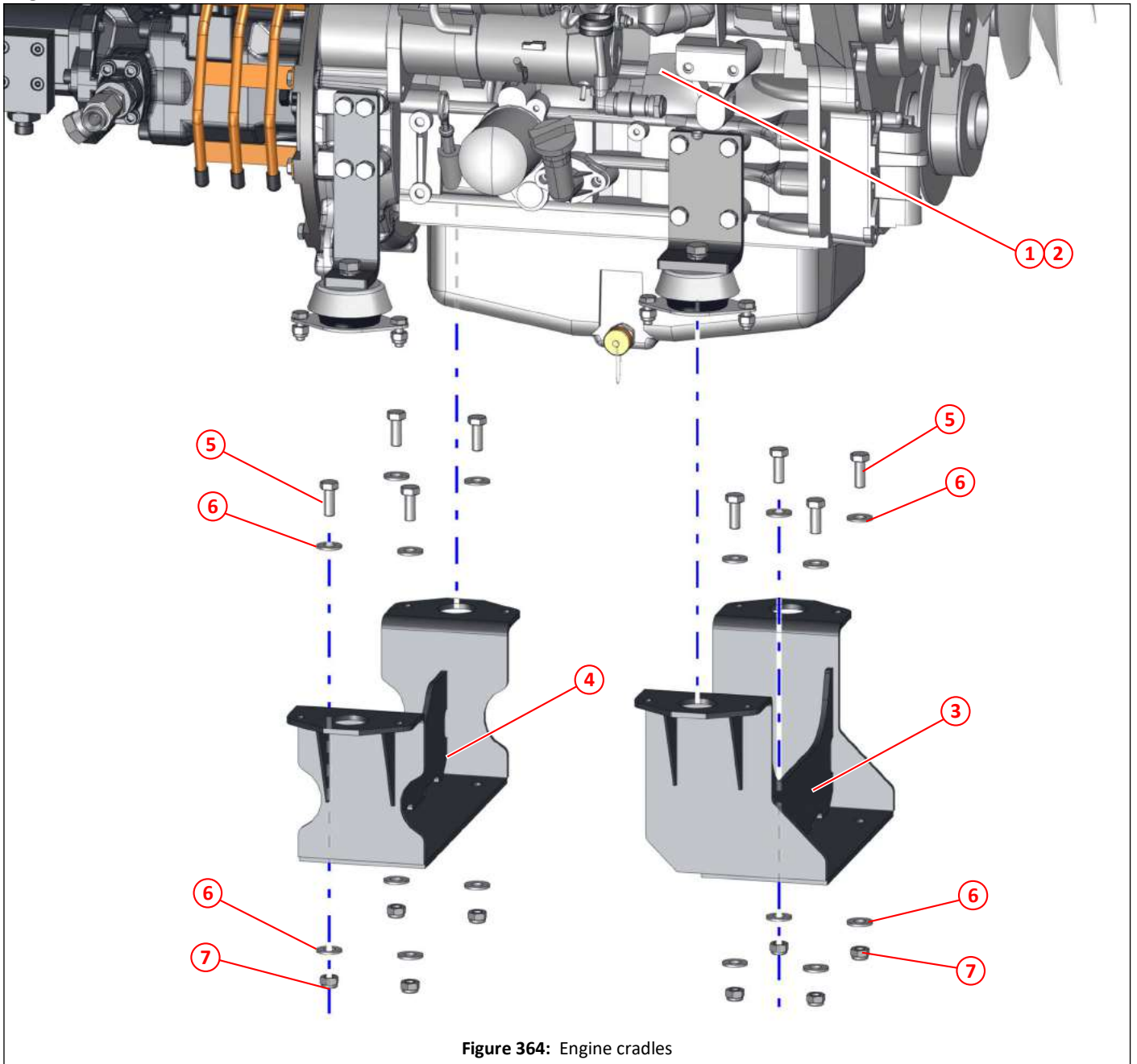

Figure 364: Engine cradles

Item	Part No	Qty	Description
①	047624	1	DEUTZ 3.6 engine (Stage V) 12V
②	046169	1	DEUTZ 3.6 engine (Stage V) 24V
③	042809	1	Engine cradle, front
④	042810	1	Engine cradle, rear
⑤	011052	8	Setscrew M12 x 30
⑥	011096	16	Washer M12
⑦	011077	8	Nyloc nut T M12

Engine mounts

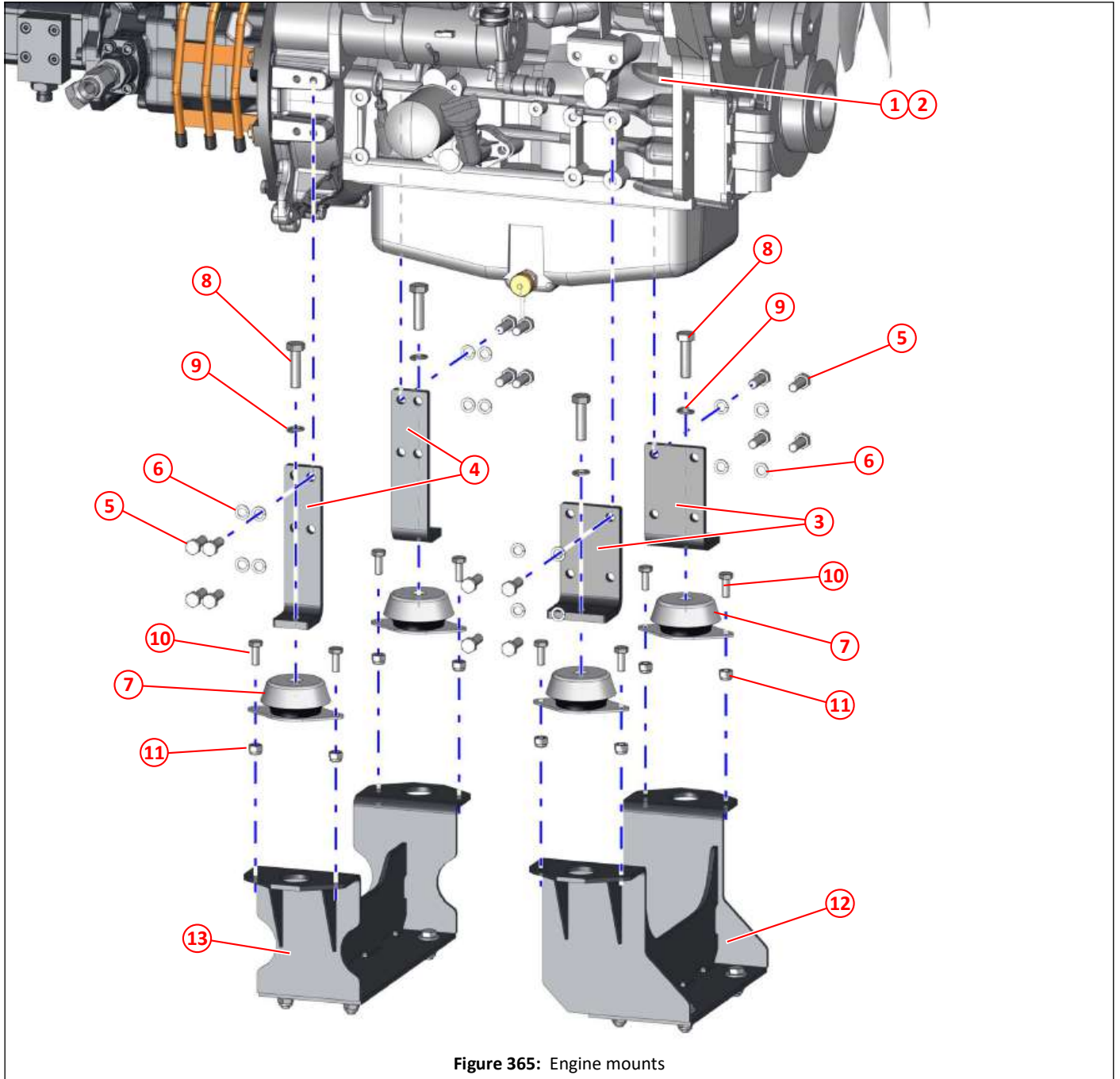

Figure 365: Engine mounts

Item	Part No	Qty	Description
①	047624	1	DEUTZ 3.6 engine (Stage V) 12V
②	046169	1	DEUTZ 3.6 engine (Stage V) 24V
③	042808	2	Engine mounting, front
④	042811	2	Engine mounting, rear
⑤	000552	16	Setscrew HT M12 x 1.75 x 35 10.9 BZP
⑥	011097	16	Spring washer M12
⑦	030724	4	Engine mount
⑧	000553	4	Bolt M14 x 2 x 50 10.9 BZP
⑨	011106	4	Spring washer M14
⑩	011031	8	Setscrew M10 x 25
⑪	011075	8	Nyloc nut T M10
⑫	042809	1	Engine cradle, front
⑬	042810	1	Engine cradle, rear

Cooling fan and water pump

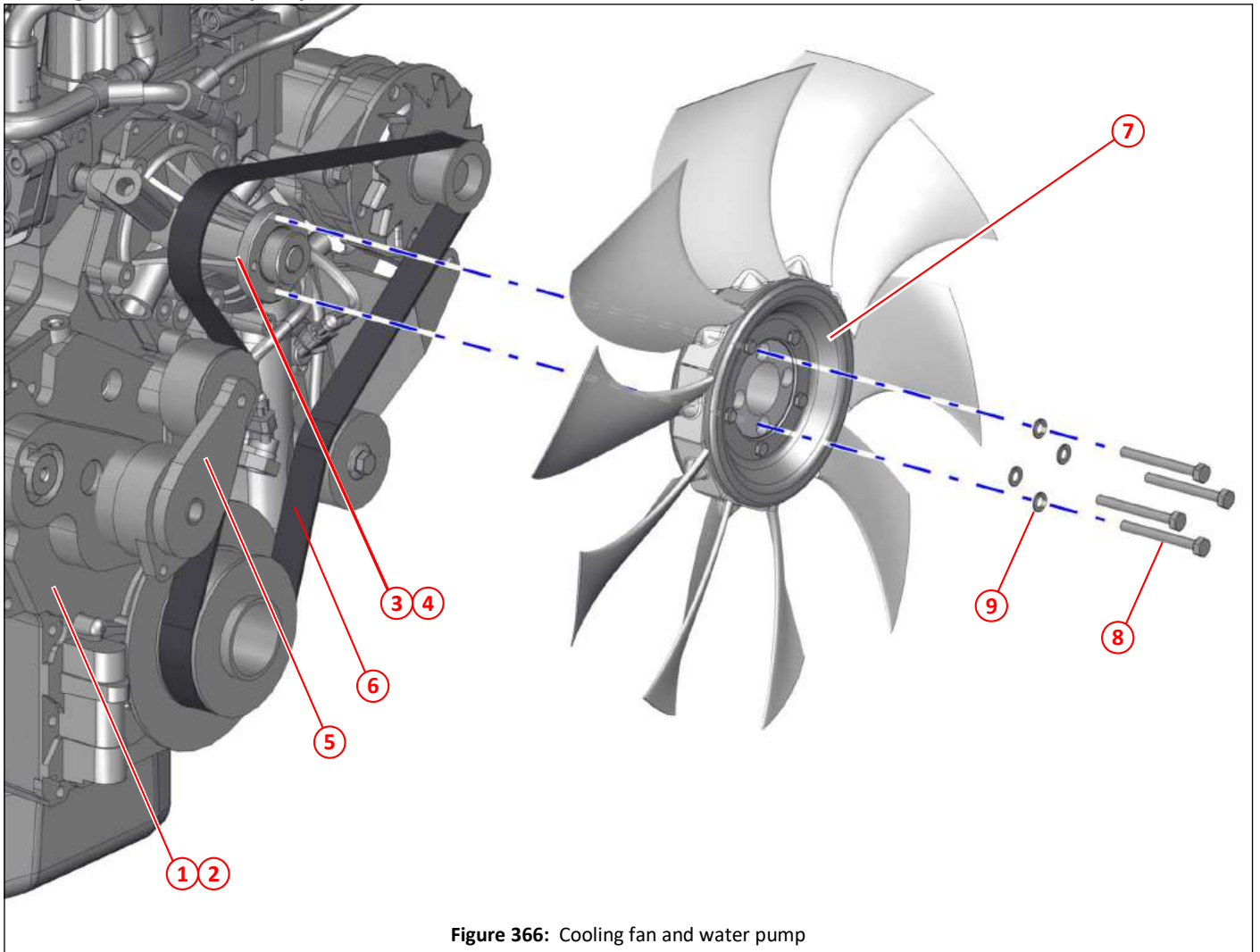

Figure 366: Cooling fan and water pump

Item	Part No	Qty	Description
①	047624	1	DEUTZ 3.6 engine (Stage V) 12V
②	046169	1	DEUTZ 3.6 engine (Stage V) 24V
③	046851	1	Water pump
④	046690	1	Pulley, water pump pulley (not shown)
⑤	043815	1	Tensioner, V ribbed belt
⑥	043789	1	V ribbed belt 3.6L4 DEUTZ
⑦	043161	1	Fan and hub kit
⑧	011018	4	Bolt M8 x 70
⑨	011093	4	Spring washer M8

Ancillary belt, tensioner, alternator and engine speed sensors

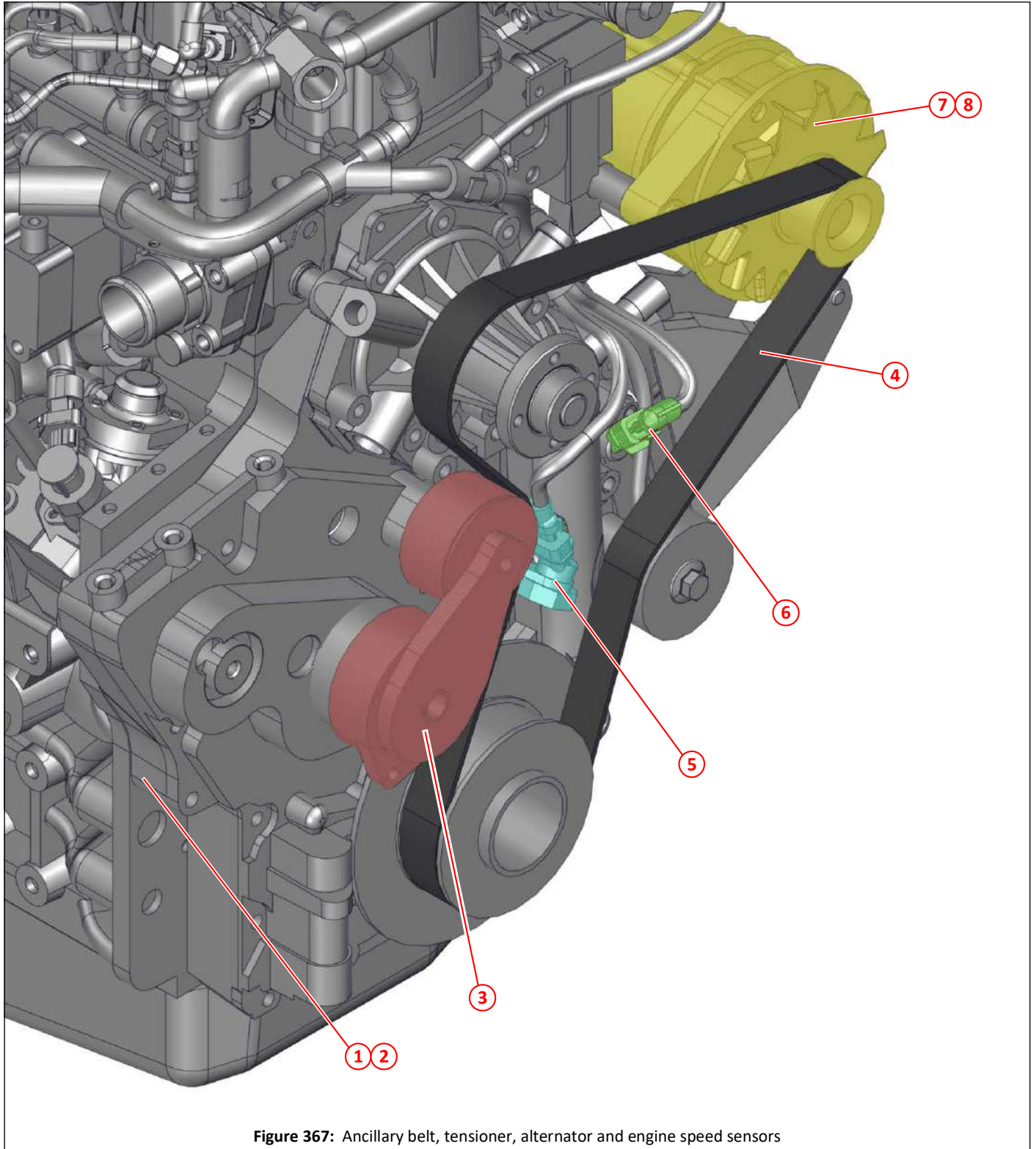

Figure 367: Ancillary belt, tensioner, alternator and engine speed sensors

Item	Part No	Qty	Description
①	047624	1	DEUTZ 3.6 engine (Stage V) 12V
②	046169	1	DEUTZ 3.6 engine (Stage V) 24V
③	043815	1	Tensioner, V ribbed belt
④	043789	1	V ribbed belt 3.6L4 DEUTZ
⑤	043797	1	Speed sensor, crankshaft
⑥	043797	1	Speed sensor, camshaft
⑦	044517	1	Alternator 14V 95A 3.6L4 DEUTZ
⑧	043816	1	Alternator 28V 55A 3.6L4 DEUTZ

Starter motor

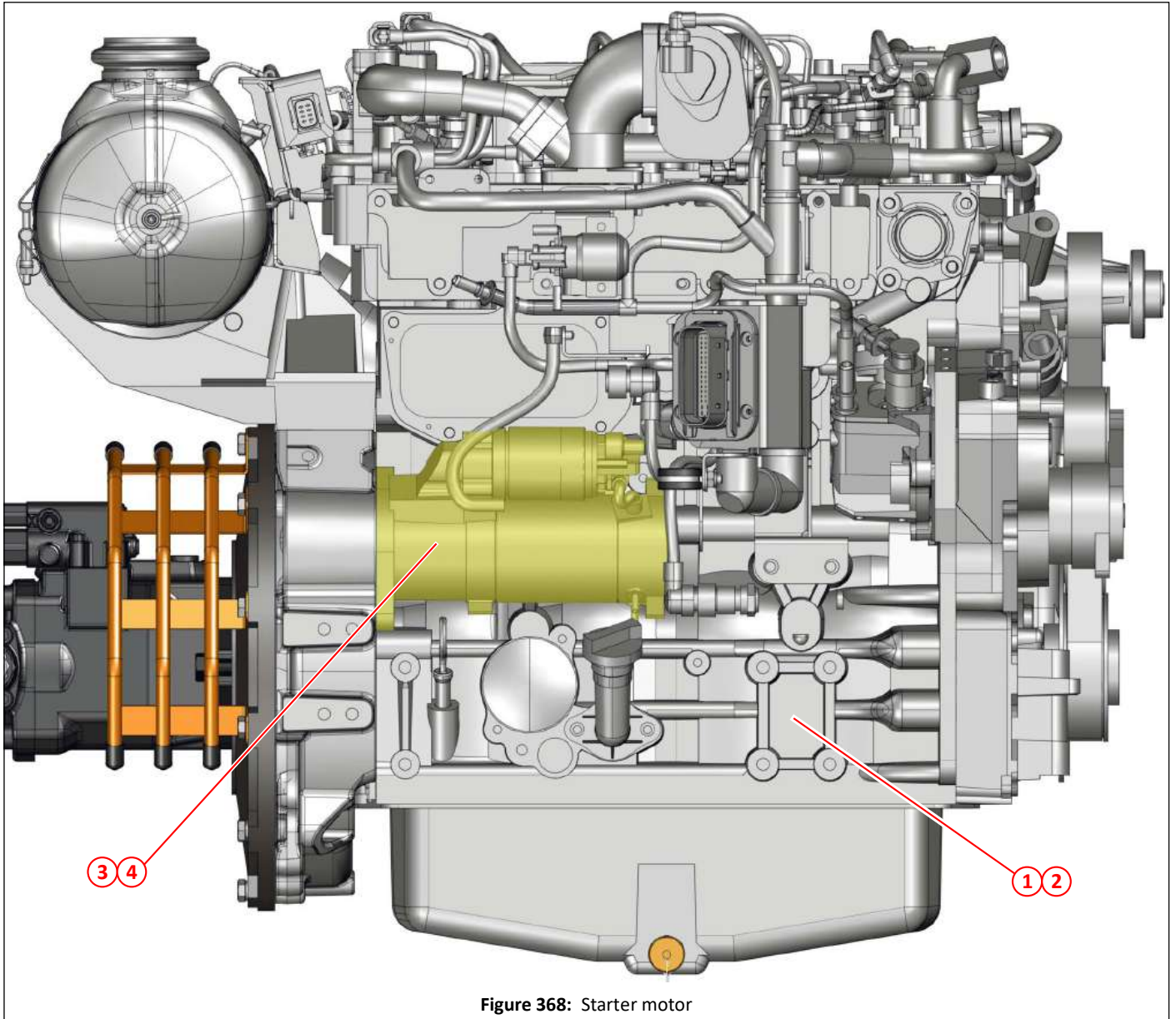

Figure 368: Starter motor

Item	Part No	Qty	Description	
①	047624	1	DEUTZ 3.6 engine (Stage V) 12V	
②	046169	1	DEUTZ 3.6 engine (Stage V) 24V	
③	044516	1	Starter motor 12V	
④	043795	1	Starter motor 24V	

Rail pressure sensor, charge air pressure and temp sensor

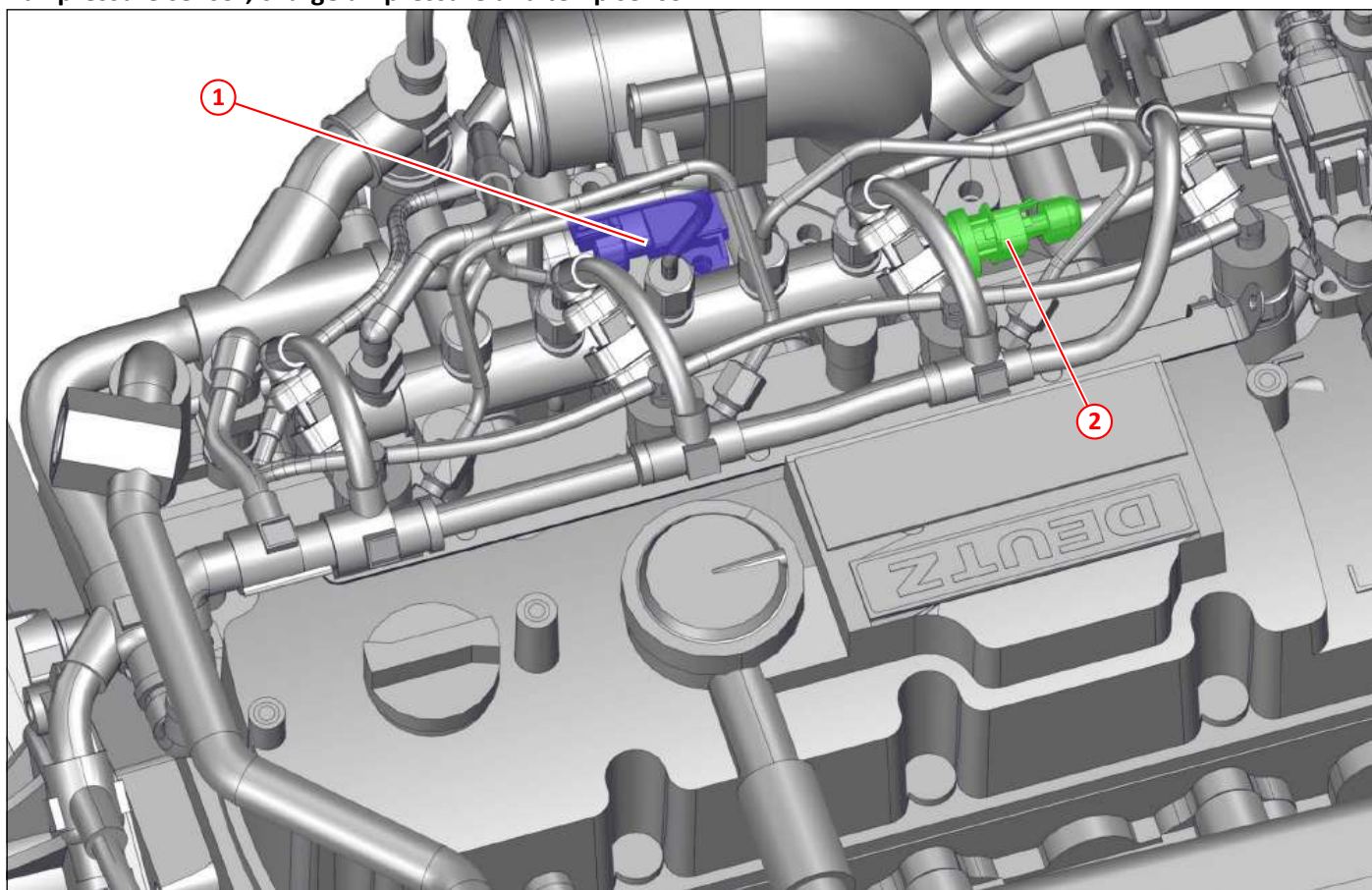

Figure 369: Rail pressure sensor, charge air pressure and temp sensor

Item	Part No	Qty	Description
①	043798	1	Charge air pressure transmitter and charge air temperature transmitter
②	043785	1	Pressure sensor, rail

Coolant temperature sensor

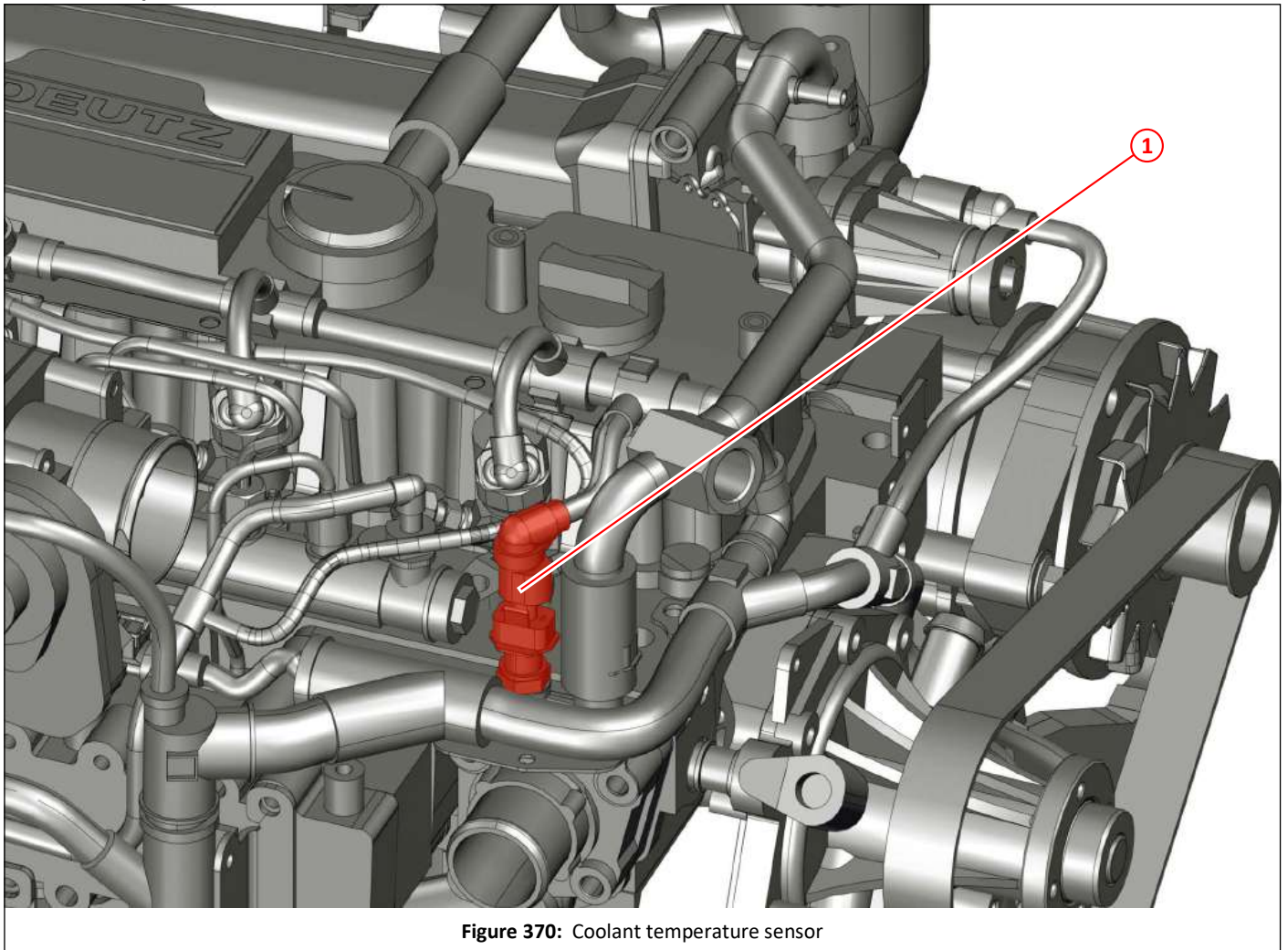

Figure 370: Coolant temperature sensor

Item	Part No	Qty	Description	
①	043814	1	Coolant temperature sender	

Lube oil pressure sensor

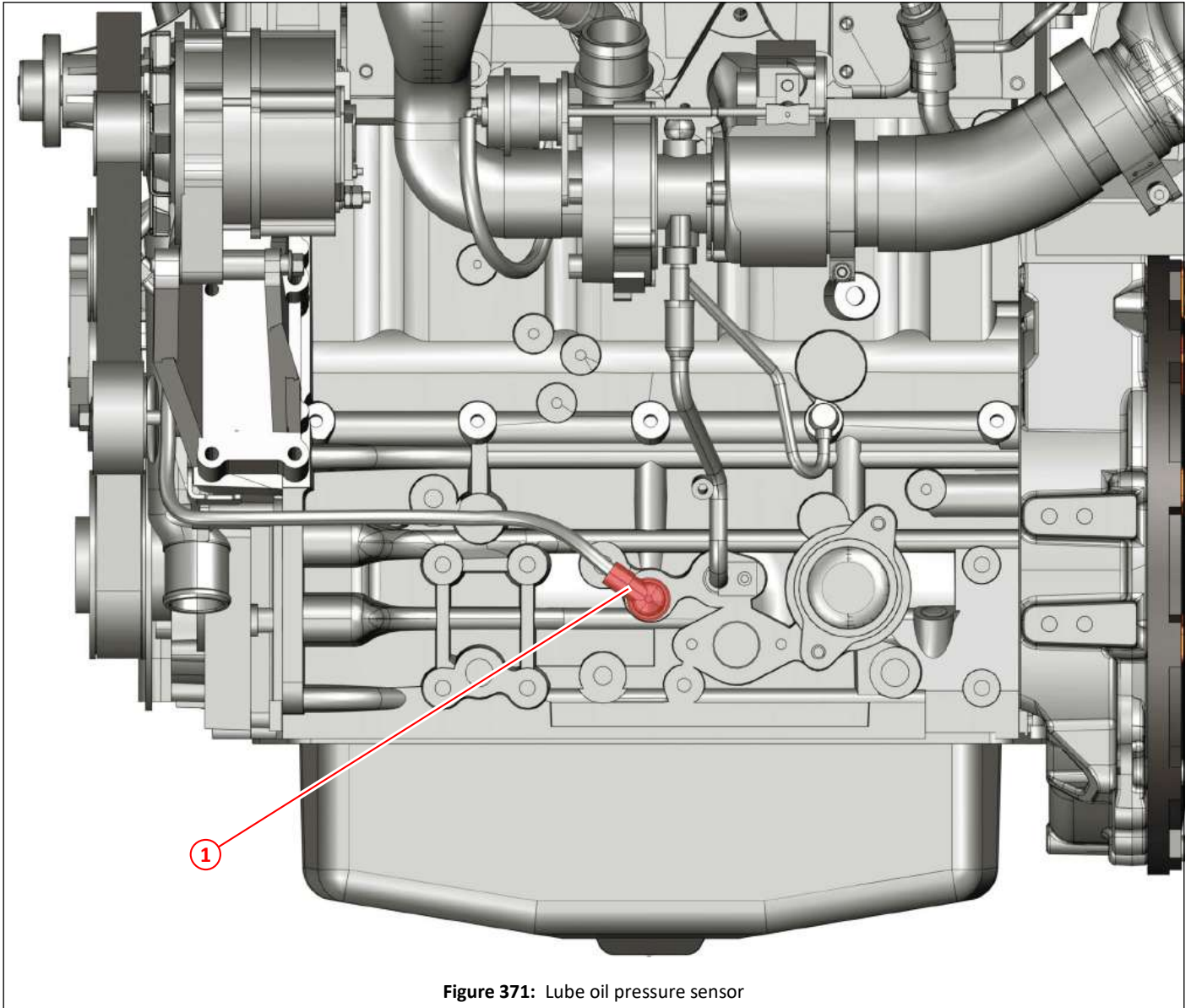

Figure 371: Lube oil pressure sensor

Item	Part No	Qty	Description	
①	043785	1	Pressure sensor, lube oil	

Injectors and glow plugs

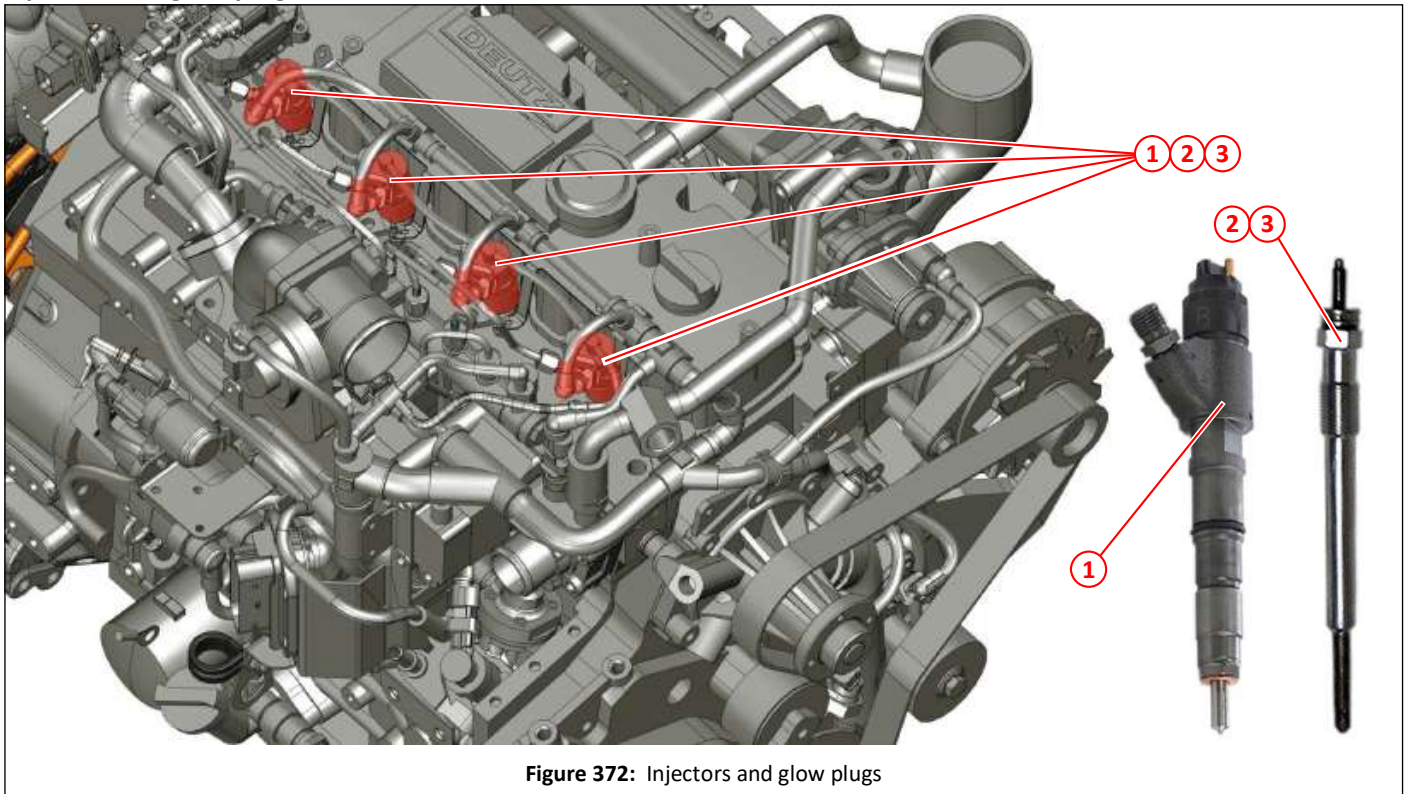

Figure 372: Injectors and glow plugs

Item	Part No	Qty	Description	
①	043793	4	Fuel injector	
②	043820	4	Glow plug, 12V	
③	043799	4	Glow plug, 24V	

Engine, ECU, EAT, and sump drain

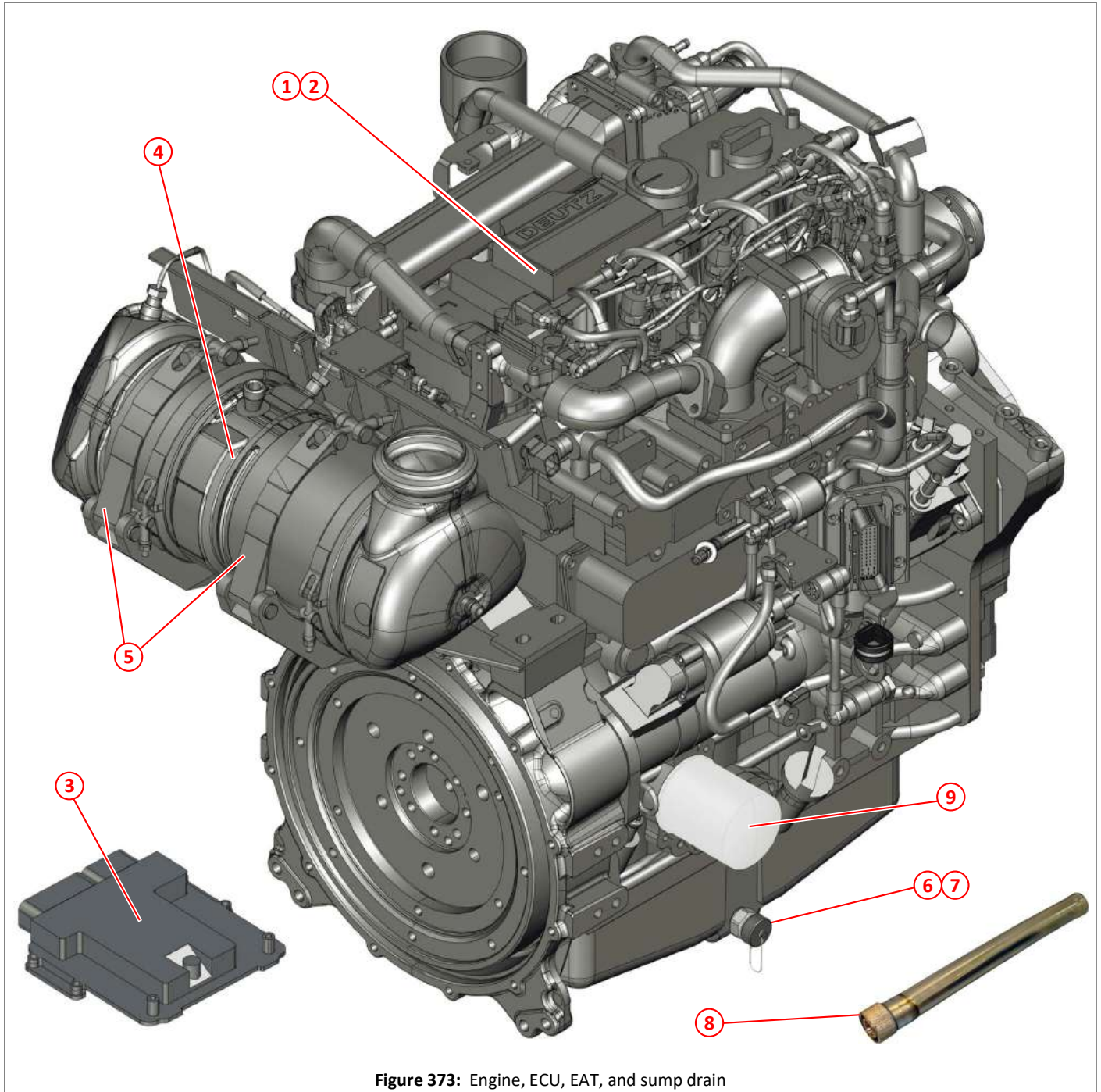

Figure 373: Engine, ECU, EAT, and sump drain

Item	Part No	Qty	Description
①	047624	1	DEUTZ 3.6 engine (Stage V), 12V
②	046169	1	DEUTZ 3.6 engine (Stage V), 24V
③	046220 *	1	ECU, DEUTZ engine 3.6 (Stage V), for both 12V and 24V.
④	045980	1	DEUTZ EAT
⑤	045981	2	Clamp, DEUTZ EAT
⑥	043568	1	Drain valve, sump
⑦	043567	1	Sealing ring, sump drain valve
⑧	043569	1	Connector and drain hose, sump drain
⑨	042232	1	Lube oil filter

*. The ECU will need to be matched to the serial number of the DEUTZ auxiliary engine of your vehicle.

Fuel pump and filters

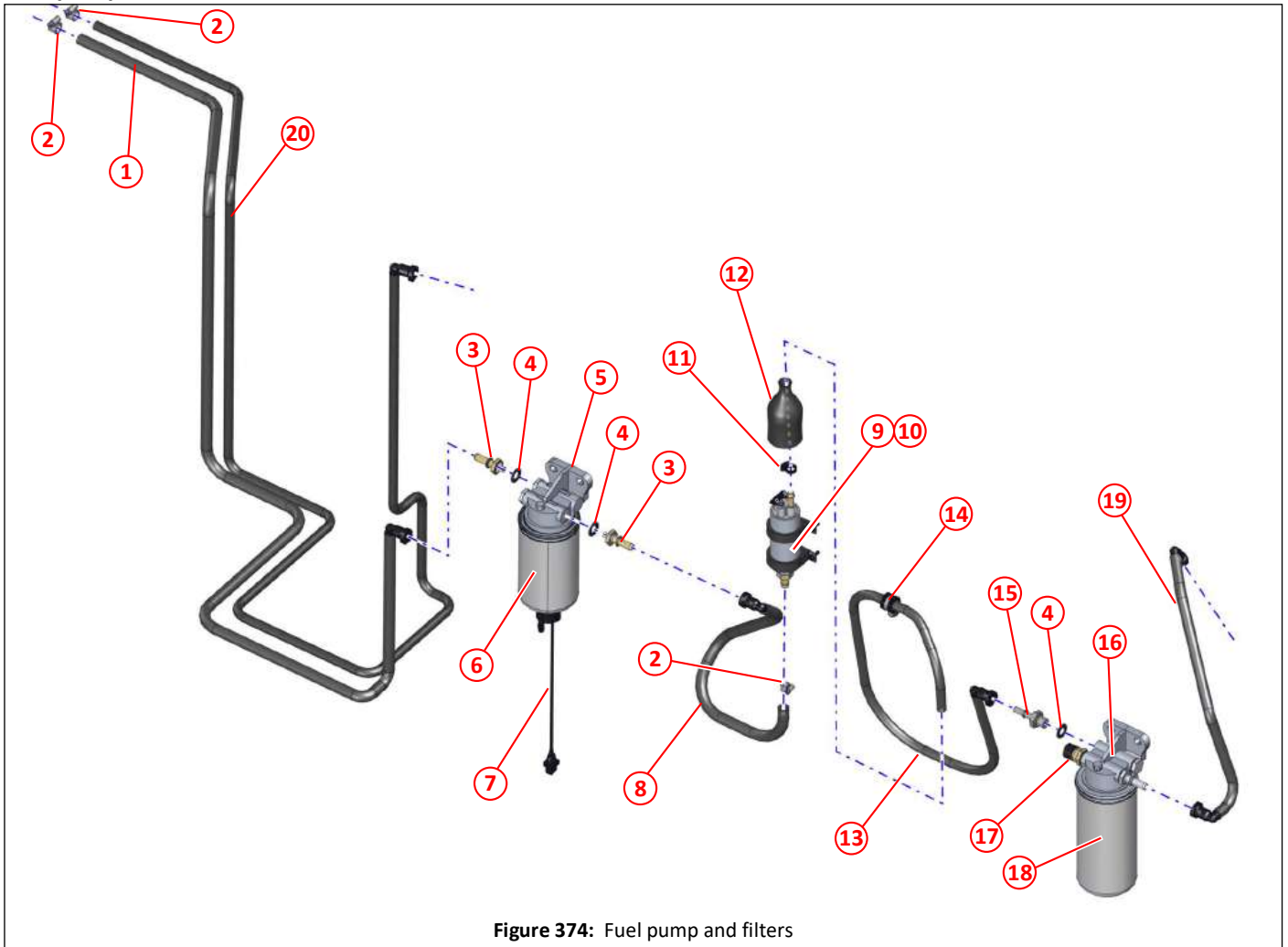

Figure 374: Fuel pump and filters

Item	Part No	Qty	Description
①	047361	1	Fuel hose, tank to primary fuel filter
②	005136	3	Jubilee clip No. 000 (ø9.5 - ø12)
③	043647	2	DEUTZ fuel hose fitting
④	011217	3	Dowty seal M16
⑤	041699	1	Primary fuel filter assembly, includes items ⑥ and ⑦.
⑥	042234	1	Filter element, primary fuel filter, includes item ⑦.
⑦	045113	1	Water in fuel (WIF) sensor, fuel filter, with cable
⑧	047362	1	Fuel hose, primary fuel filter to lift pump
⑨	044515	1	Fuel lift pump, 3.6L4 DEUTZ, 12V
⑩	043370	1	Fuel lift pump, 3.6L4 DEUTZ, 24V
⑪	043709	1	Nylon 6.6 plastic hose clip ø15.0 - ø17.1mm
⑫	042604	1	Boot, fuel lift pump
⑬	043034	1	Fuel hose, lift pump to secondary fuel filter
⑭	000200	1	Clip ø18, rubber sleeved
⑮	042903	1	M16 to $\frac{3}{8}$ " (SAE J2044), quick change adapter
⑯	043035	1	Secondary fuel filter assembly, includes item ⑰.
⑰	043785	1	Pressure sensor, secondary fuel filter
⑱	043786	1	Filter element, secondary fuel filter
⑲	043033	1	Fuel hose, secondary filter to engine
⑳	043031	1	Fuel hose, return to tank

Exhaust stack

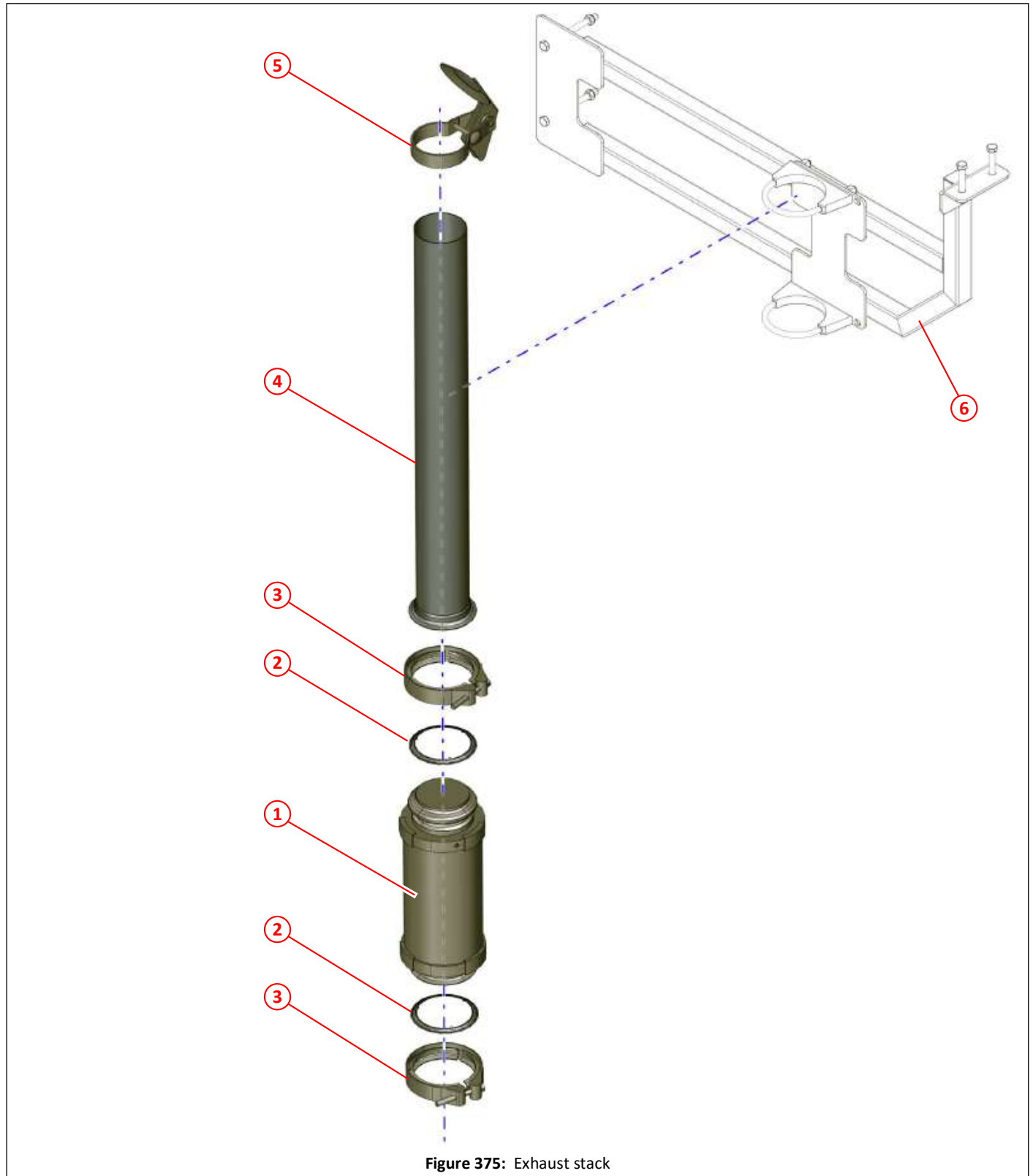

Figure 375: Exhaust stack

Item	Part No	Qty	Description	
①	041693	1	Flexible union, exhaust	
②	041697	2	Compression seal, exhaust	
③	041694	2	V clamp, exhaust	
④	046945	1	Exhaust stack	
⑤	041907	1	Exhaust rain cap	
⑥	046944	1	Exhaust support	372

Air intake stack, lower

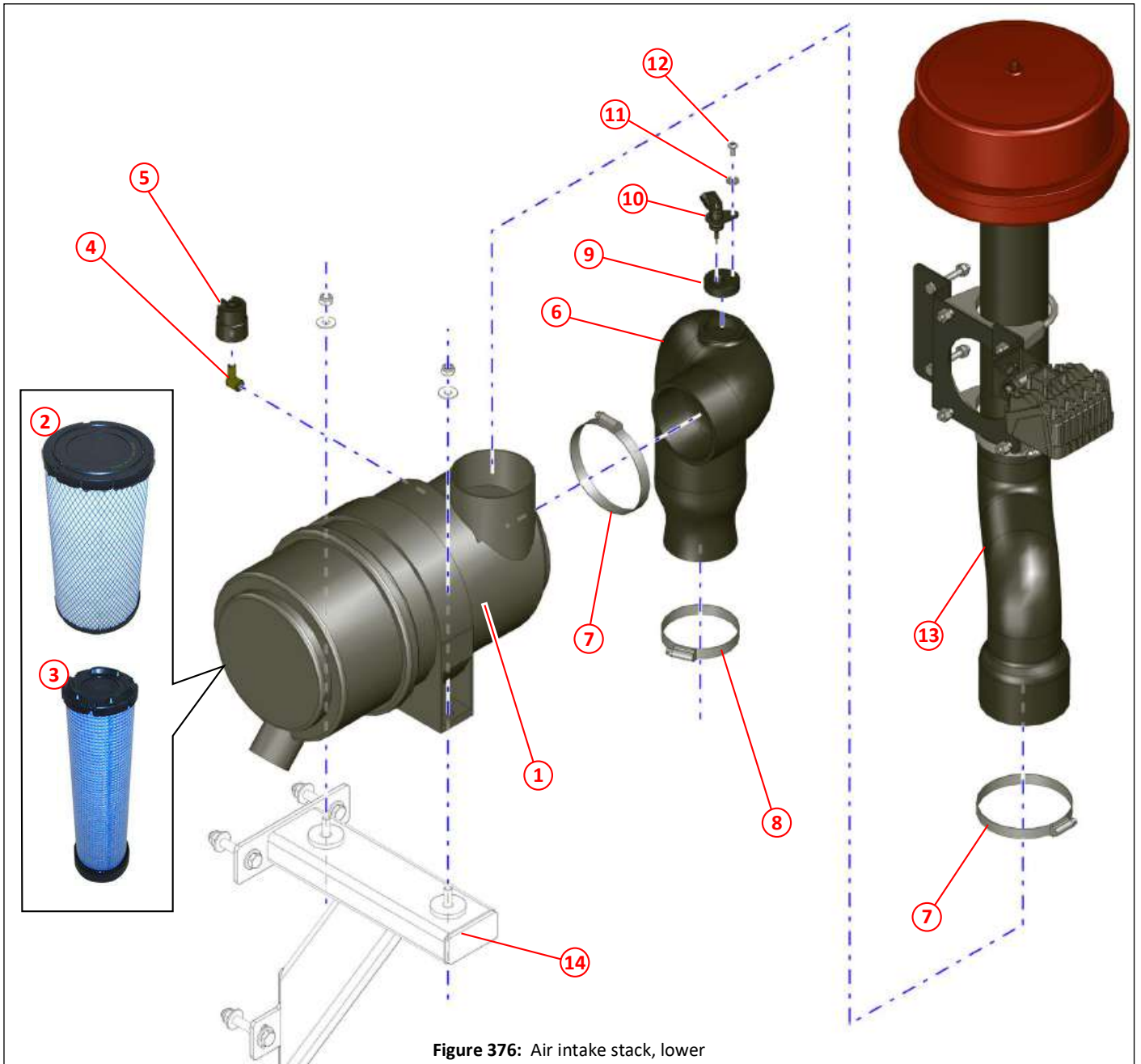

Figure 376: Air intake stack, lower

Item	Part No	Qty	Description	
①	025279	1	Air cleaner assembly, includes items ② and ③	
②	025280	1	Element, main, air cleaner	
③	025281	1	Element, safety, air cleaner	
④	034343	1	Elbow, filter blocked sender	
⑤	042136	1	Sender, filter blocked, 5.0kPa	
⑥	046552	1	Air inlet hose 'A' (Stage V)	
⑦	003003	2	Jubilee clip No 5 [ø90 - ø120]	
⑧	012931	1	Jubilee clip No 4 [ø70 - ø90]	
⑨	046553	1	Insert, air inlet hose (Stage V)	
⑩	047146	1	Temperature sensor (Stage V)	
⑪	011090	1	Washer M6	
⑫	000518	1	Button head socket screw M6 x 12, plated	
⑬			Air intake stack, upper	414
⑭	042920	1	Air cleaner mounting bracket	373

Air intake stack, upper

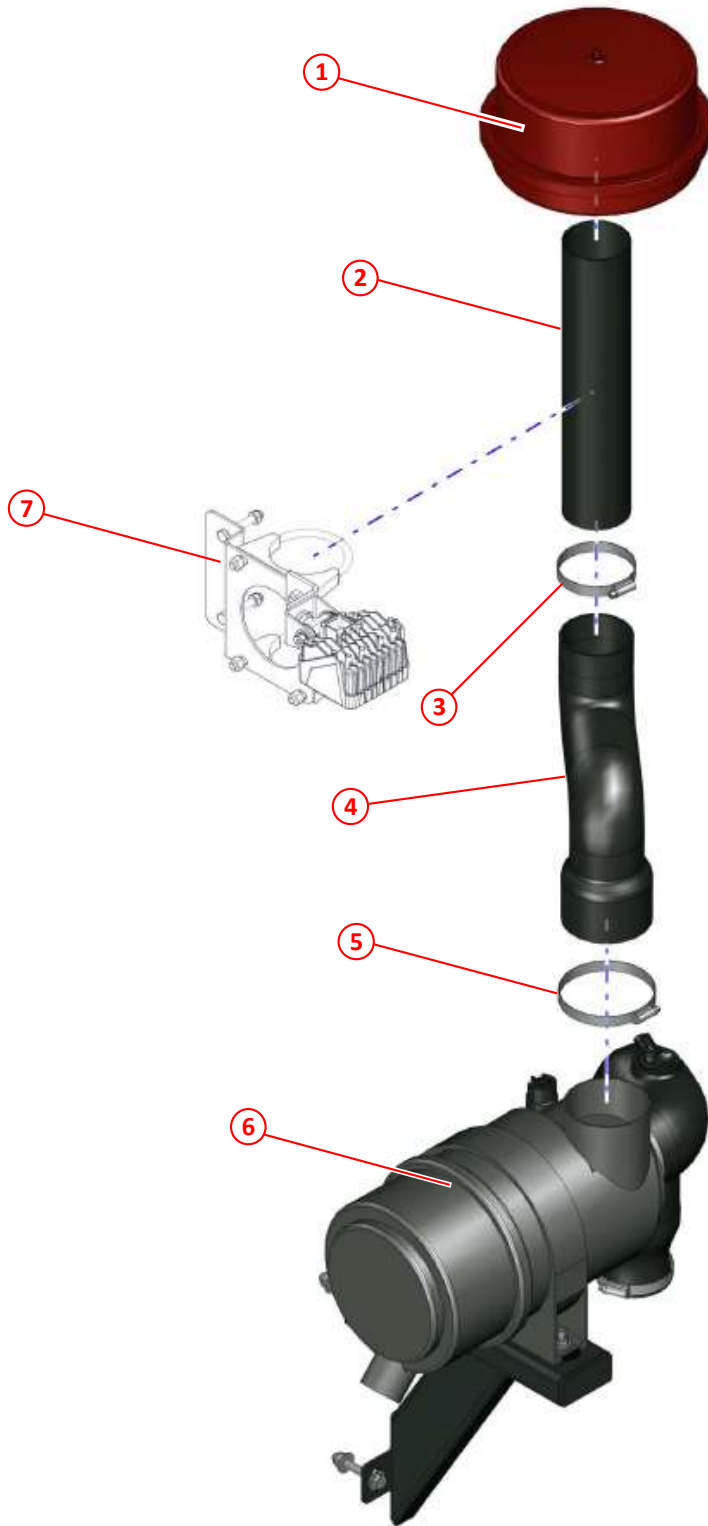

Figure 377: Air intake stack, upper

Item	Part No	Qty	Description	
①	043680	1	Pre-cleaner cyclonic	
②	042915	1	Air intake stack	
③	012931	1	Jubilee clip No 4 [ø70 - ø90]	
④	042999	1	Air inlet hose 'B' (Stage V)	
⑤	003003	1	Jubilee clip No 5 [ø90 - ø120]	
⑥	025279	1	Air cleaner assembly	413
⑦	046948	1	Air stack bracket	373

Coolant expansion tank

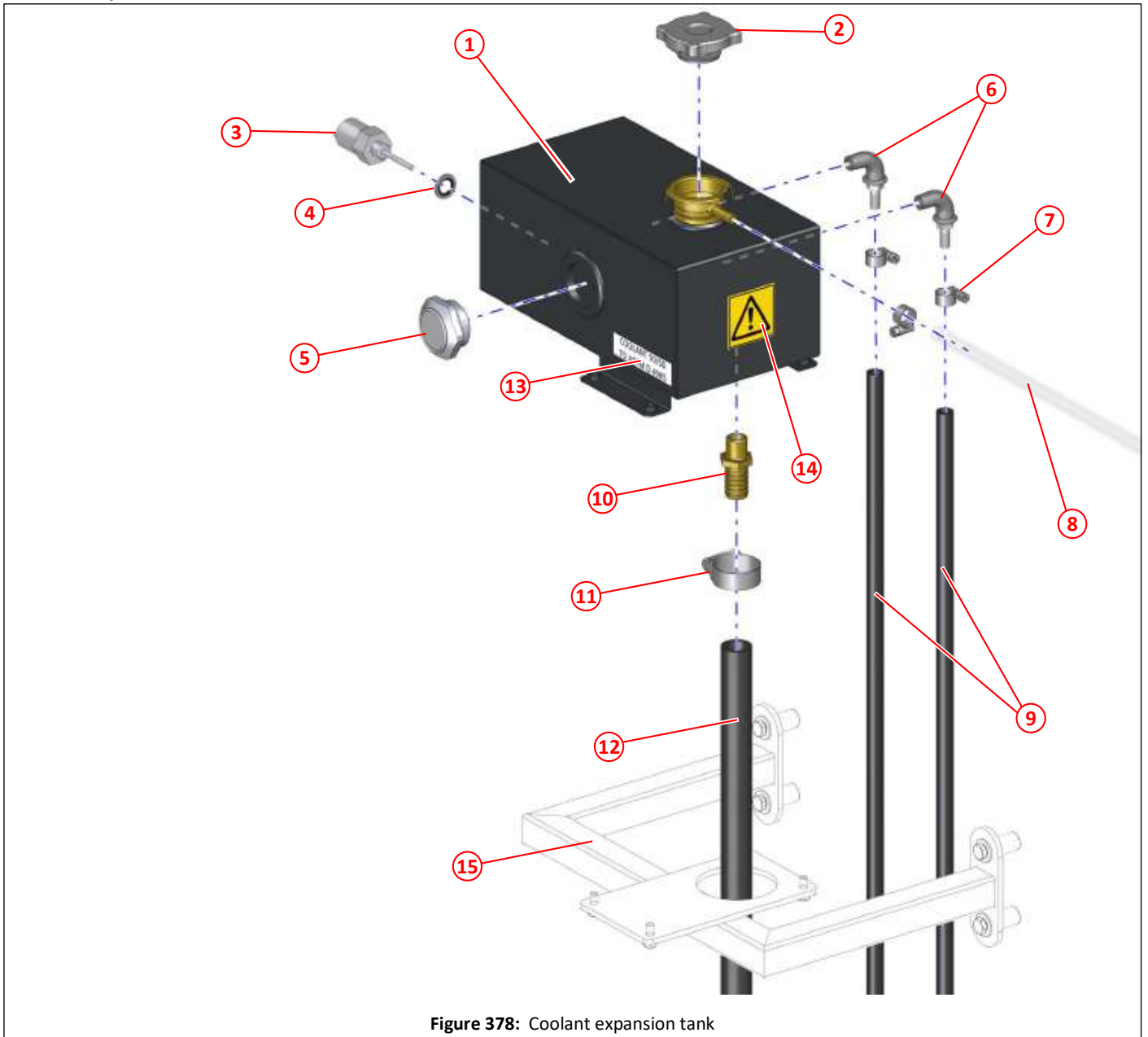

Figure 378: Coolant expansion tank

Item	Part No	Qty	Description	
①	041936	1	Expansion tank	
②	041945	1	Filler neck cap, expansion tank	
③	041698	1	Expansion tank level sensor	
④	011216	1	Dowty seal M14	
⑤	042333	1	Bulls-eye sight glass, 1 1/4" BSP	
⑥	010910	2	Elbow, male/female 1/4" BSP	
⑦	010516	3	Jubilee clip No MOO [ø11 - ø16]	
⑧	010951	1	Hose 3/8", clear	
⑨	001035	2	Hose 8mm heater hose	
⑩	025181	1	1/2" BSP to 3/4" hosetail	
⑪	014828	1	Jubilee clip, high torque, size 70 (ø25 - ø40mm)	
⑫	002188	1	Hose 3/4" fuel R6	
⑬	036223	1	Label - Coolant grade	
⑭	043693	1	Label - Hazard	
⑮	046946	1	Expansion tank mounting bracket	374

Combined oil/intercooler/radiator cooler

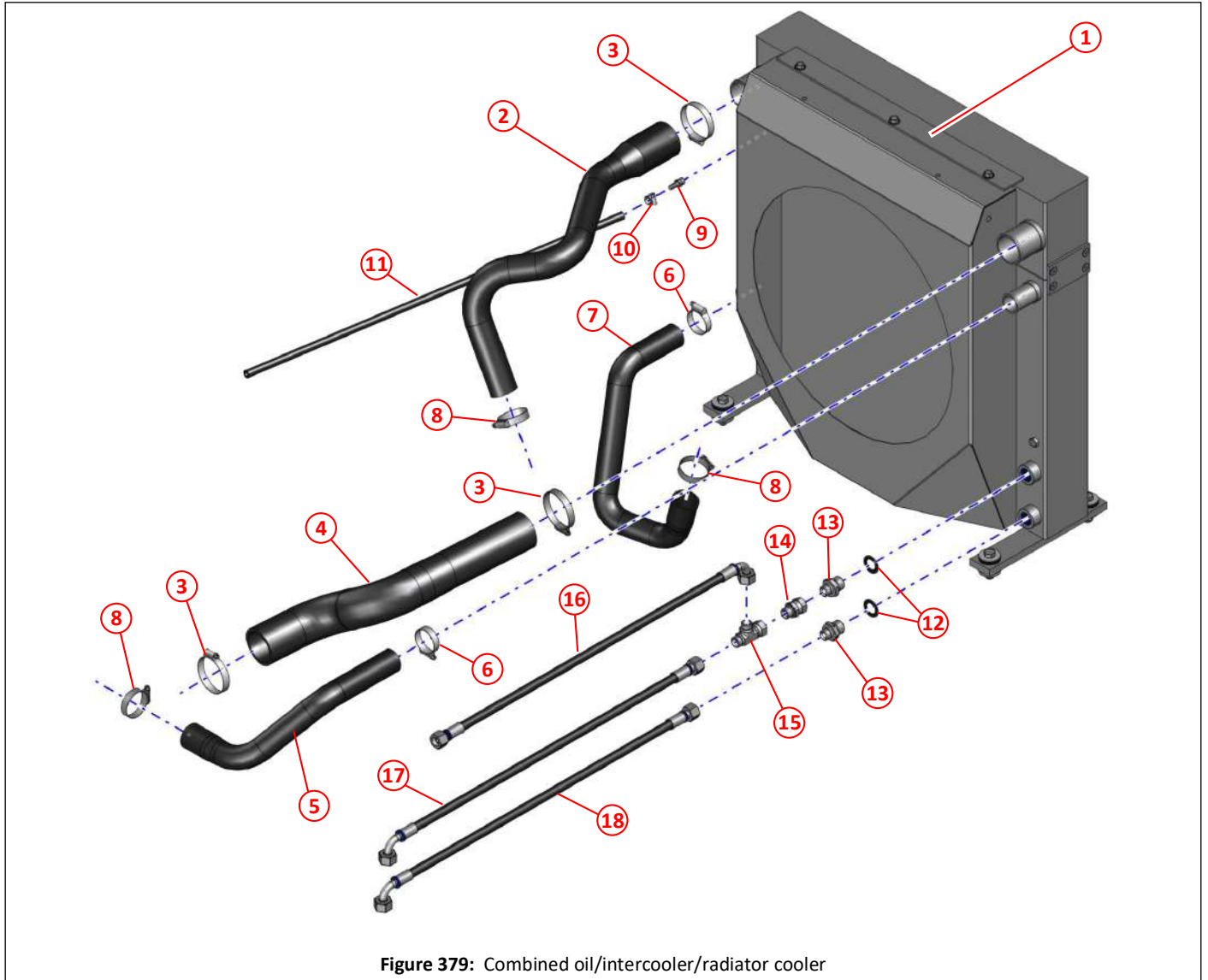

Figure 379: Combined oil/intercooler/radiator cooler

Item	Part No	Qty	Description	
①	046549	1	Combined oil/intercooler/radiator (Stage V)	367
②	042893	1	Intercooler hose 'A'	
③	010595	3	Jubilee clip No 3 [ø55 - ø70]	
④	033591	1	Intercooler hose 'B'	
⑤	042895	1	Coolant hose 'A'	
⑥	003007	2	Jubilee clip 2A [ø35 - ø50]	
⑦	042896	1	Coolant hose 'B'	
⑧	012927	3	Jubilee clip No 2 [ø40 - ø55]	
⑨	006044	1	¼" BSP male x 8mm hose tail	
⑩	010516	1	Jubilee clip No MOO [ø11 - ø16]	
⑪	001035	1	Hose 8mm heater hose, from expansion tank	
⑫	002082	2	Dowty seal M26	
⑬	002074	2	Adapter M26 x ½" BSP	
⑭	011177	1	Swivel adapter, male/female, ½" BSP	
⑮	011182	1	Tee, nut on run, ½" BSP	
⑯	001328	1	Hose ½" BSP x 970, straight/90°, to T2 on Main valve block	280
⑰	030992	1	Hose ½" BSP x 1100, straight/90°, to T1 on Main valve block	280
⑱	001368	1	Hose ½" BSP x 3370, straight/90°	

Centaflex coupling and fan pump housing plate

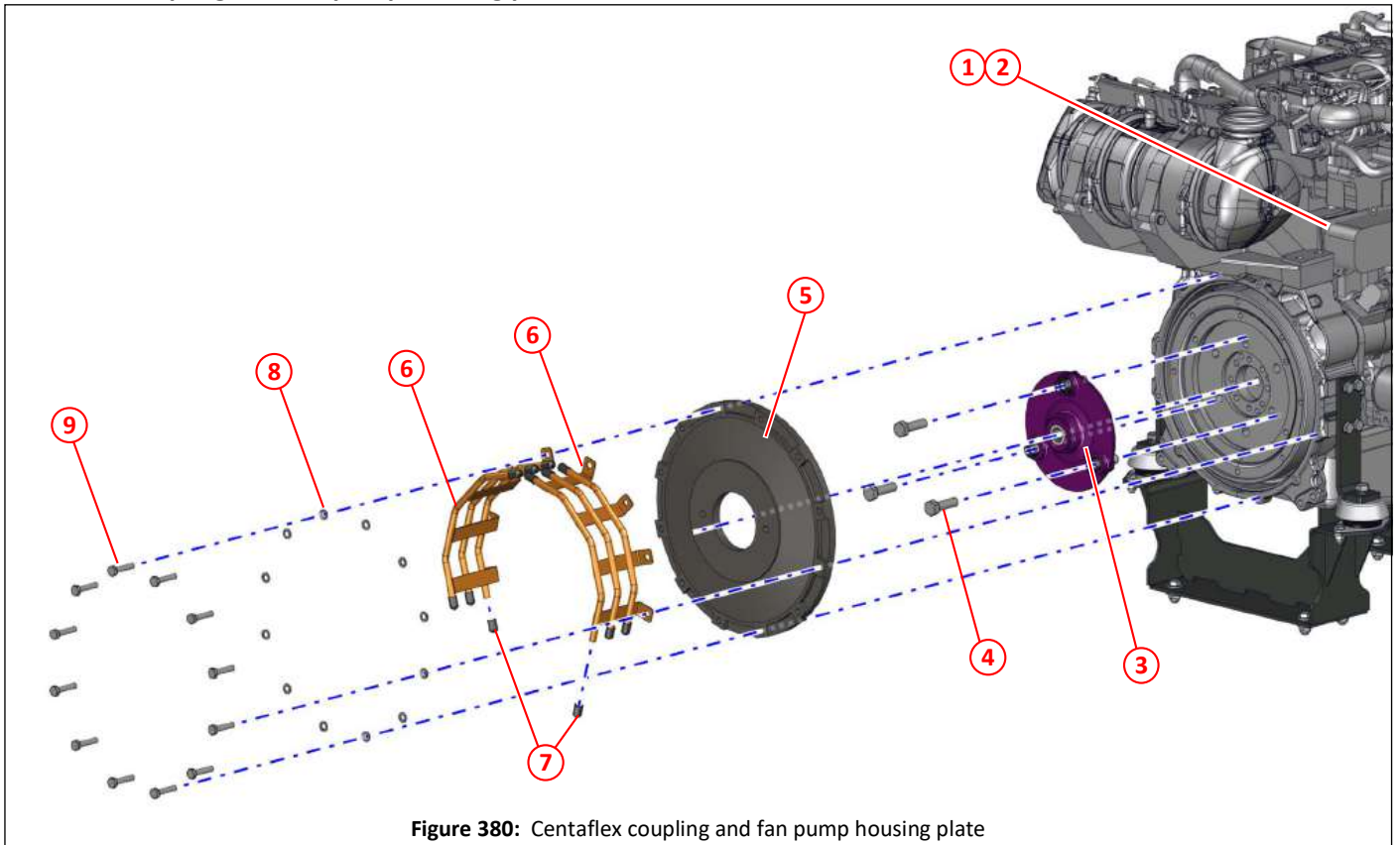



Figure 380: Centaflex coupling and fan pump housing plate

Item	Part No	Qty	Description
①	047624	1	DEUTZ 3.6 engine (Stage V), 12V
②	046169	1	DEUTZ 3.6 engine (Stage V), 24V
③	043081	1	Centaflex KE coupling
④	000473	3	Setscrew HT M16 x 2 x 50
⑤	042813	1	Adapter plate
⑥	042979	2	Cable guide, adapter plate
⑦	043065	12	Pipe cap ø12
⑧	011095	12	Spring washer M10
⑨	000072	12	Setscrew HT M10 x 45

Engine

Service kits

Part No	Description	
SCAKIT046243	Service kit every 500 hours	
SCAKIT046244	Service kit every 1000 hours	
SCAKIT048687	Service kit every 2000 hours	
SCAKIT046246	Service kit every 3000 hours	

Cab

<i>Description</i>	<i>Page</i>
General layout of cab items	420
Main control panel and operator screen mountings	421
Main control panel	422
Auxiliary (door pod) control panel and node mountings	423
Auxiliary controller (door pod)	424
Operator screen and camera monitor mounting	425
Main control panel and operator screen mountings	426
Brush pressure valve, gauge and controls	427
Remote hopper controller	428
Other components, cab components	429

General layout of cab items



Main controller, operator screen and auxiliary controller



Main controller, operator screen and extra camera screen



Hopper remote controller



Brush pressure switches, pressure adjuster and gauge

Figure 381: General layout, cab components

Item	Part No	Qty	Description	
①			Main control panel	338,421
②			Auxiliary control panel (door pod)	339,423
③			Operator screen	421
④			Camera screen	421
⑤			Hopper remote controller	
⑥			Side brush pressure switch	
⑦			Central brush (wide sweep) pressure switch	
⑧			Pressure adjuster, brush	
⑨			Pressure gauge, brush	

i Please note that any mounting brackets etc. in the cab area are chassis specific, when ordering parts please have you sweepers serial number and also the type of chassis it is built on available.

Main control panel and operator screen mountings

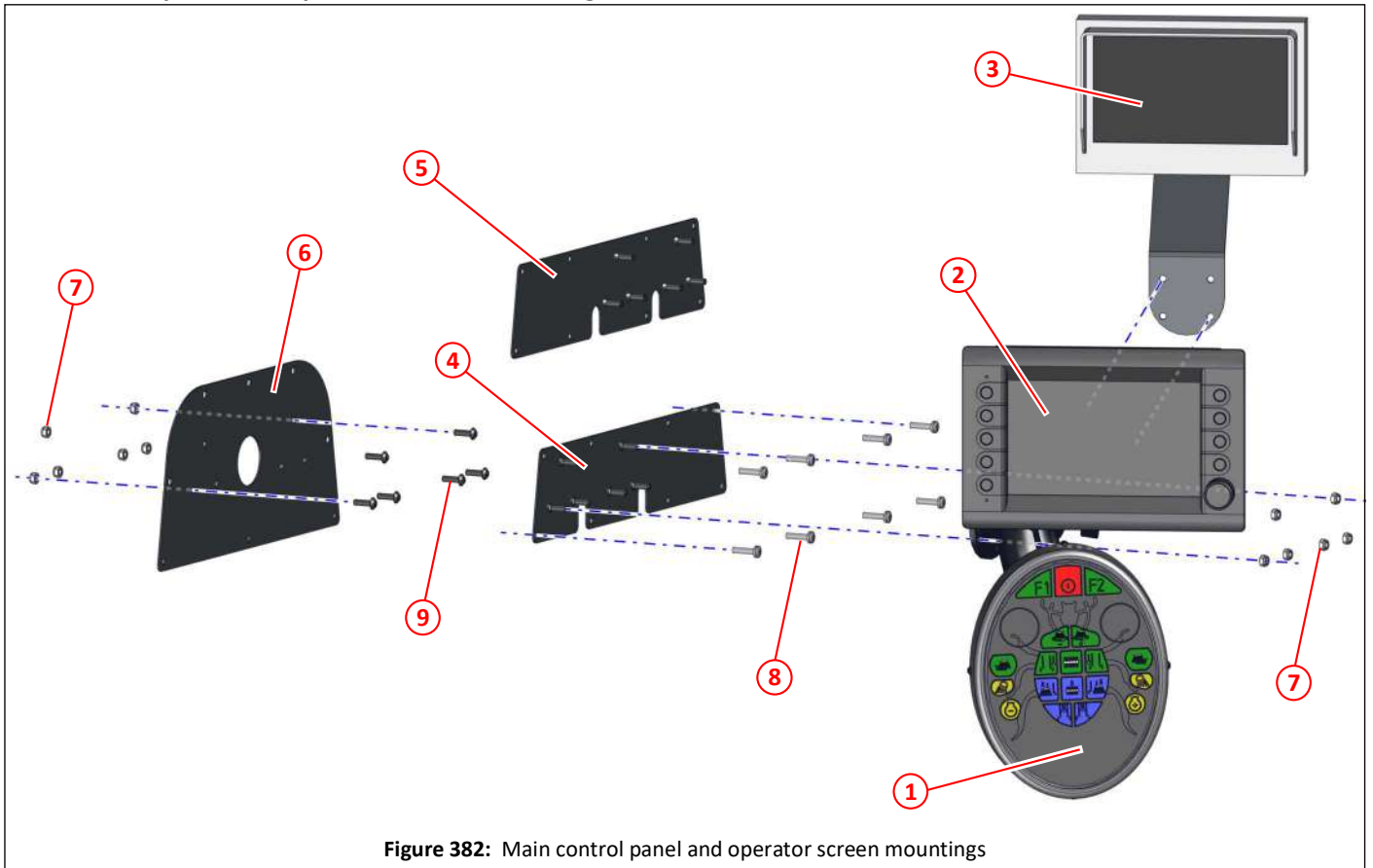

Figure 382: Main control panel and operator screen mountings

Item	Part No	Qty	Description	
①	037602	1	Main control panel, keypad and fascia	422
②	051757	1	Operator screen	420
③	040717 *	1	Camera monitor	420
④	042034 †	1	Keypad and screen plate, left hand drive	
⑤	043042 †	1	Keypad and screen plate, right hand drive	
⑥	037297 †	1	Keypad and screen plate	
⑦	000155	6	Nyloc nut M5	
⑧	000402	8	Pan head POZIDRIV screw M5 x 20	
⑨	000346	6	Socket button head screw M5 x 16, black	

*. Various monitors are available for camera viewing, Please contact Scarab Parts Department.

†. These items are chassis specific and are shown as examples. When ordering parts please have your sweeper serial number and type of chassis it is built on available.

i Due to the many chassis and variants available it is not practical to list all of the fittings and quantities for attaching items to the chassis, please use appropriate fittings and if in any doubt contact Scarab Sweepers for advice.

Main control panel

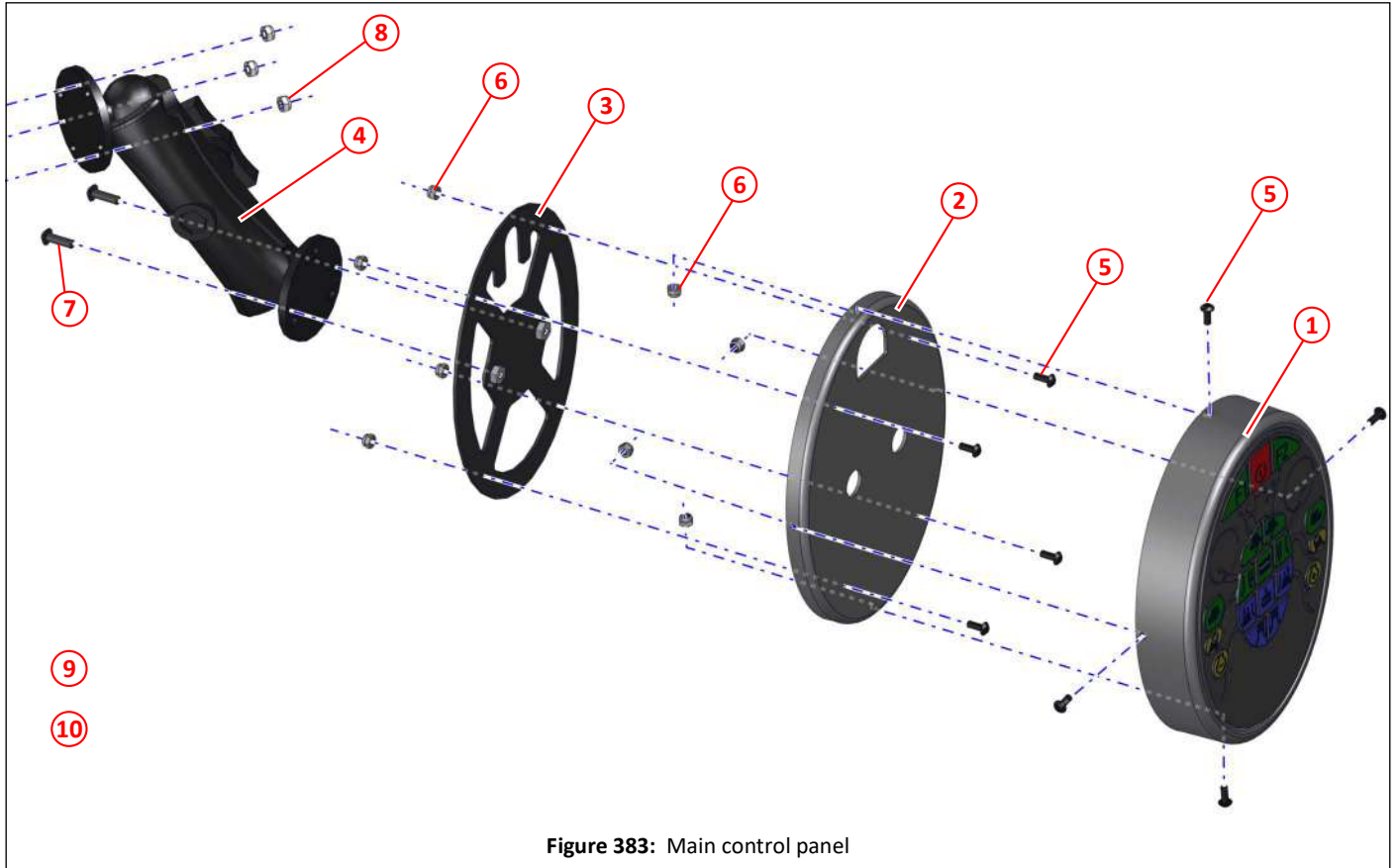

Figure 383: Main control panel

Item	Part No	Qty	Description	
①	037602	1	Keypad fascia kit, main control pane	338,420,421
②	037053	1	Backplate, main control panel	
③	037055	1	Spider plate. main control panel	
④	032108	1	Adjustable panel mount, ram	
⑤	000304	8	Socket button head screw M4 x 10, black	
⑥	000134	8	Nyloc nut M4	
⑦	000346	2	Socket button head screw M5 x 16, black	
⑧	000155	3	Nyloc nut M5	
⑨	036912	1	Loom, main control panel	338,352
⑩	036914	1	Loom, power/CAN, main control panel	338,352

i Due to the many chassis and variants available it is not practical to list all of the fittings for attaching items to the chassis, please use appropriate fittings and if in any doubt contact Scarab Sweepers for advice.

Auxiliary (door pod) control panel and node mountings

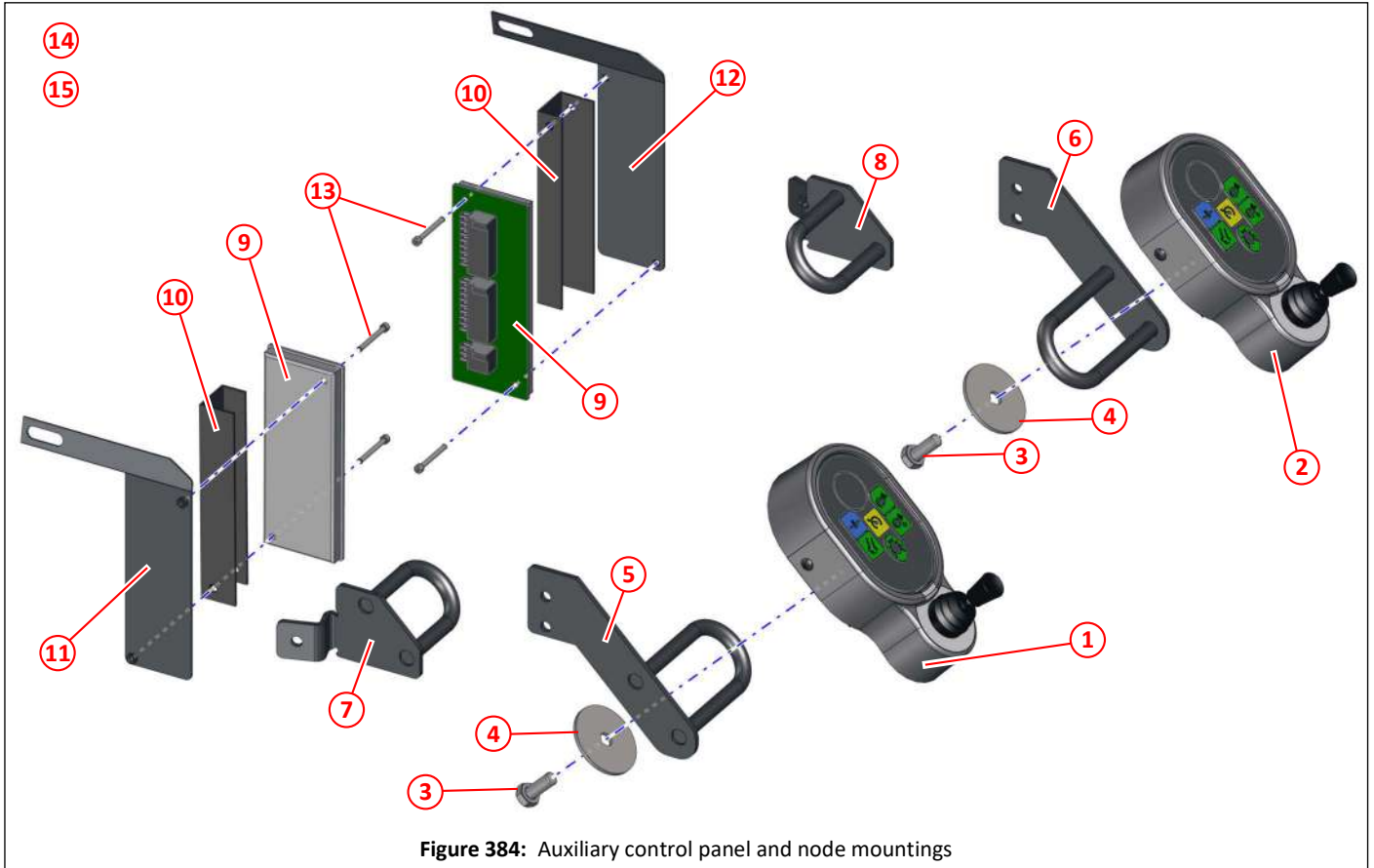

Figure 384: Auxiliary control panel and node mountings

Item	Part No	Qty	Description	
①	037606 *	1	Auxiliary controller (door pod), left hand side, includes items ③ and ④	339
②	037607 *	1	Auxiliary controller (door pod), right hand side, includes items ③ and ④	339
③	011031 *	1	Setscrew HT M10 x 25	
④	011031 *	1	Door pod lock washer	
⑤	037866 *	1	Auxiliary controller (door pod) mount, left hand side	
⑥	037296 *	1	Auxiliary controller (door pod) mount, right hand side	
⑦	033427 *	1	Auxiliary controller (door pod) mount, left hand side	
⑧	033317 *	1	Auxiliary controller (door pod) mount, right hand side	
⑨	036799 *	1	CR2012 cabinet module, (node)	340
⑩	044290 *	1	Black plastic extrusion	
⑪	042041 *	1	Bracket, node (cabinet module), left hand side	
⑫	043073 *	1	Bracket, node (cabinet module), right hand side	
⑬	000152 *	2	Socket cap head screw M4 x 3	
⑭	036913 *	1	Loom, auxiliary control panel (door pod)	339,352
⑮	036915 *	1	Loom, power/CAN, auxiliary control panel (door pod)	339,352

*. These are examples of brackets for mounting the auxiliary controller and/or the nodes (cabinet modules). If ordering, then please contact Scarab Parts Department and have your sweeper serial number and type of chassis it is built on available, to ensure correct parts selection. Any quantities shown are per controller/node. If dual steer then both left and right controllers/nodes will be fitted.

i Due to the many chassis and variants available it is not practical to list all of the fittings for attaching items to the chassis, please use appropriate fittings and if in any doubt contact Scarab Sweepers for advice.

Auxiliary controller (door pod)

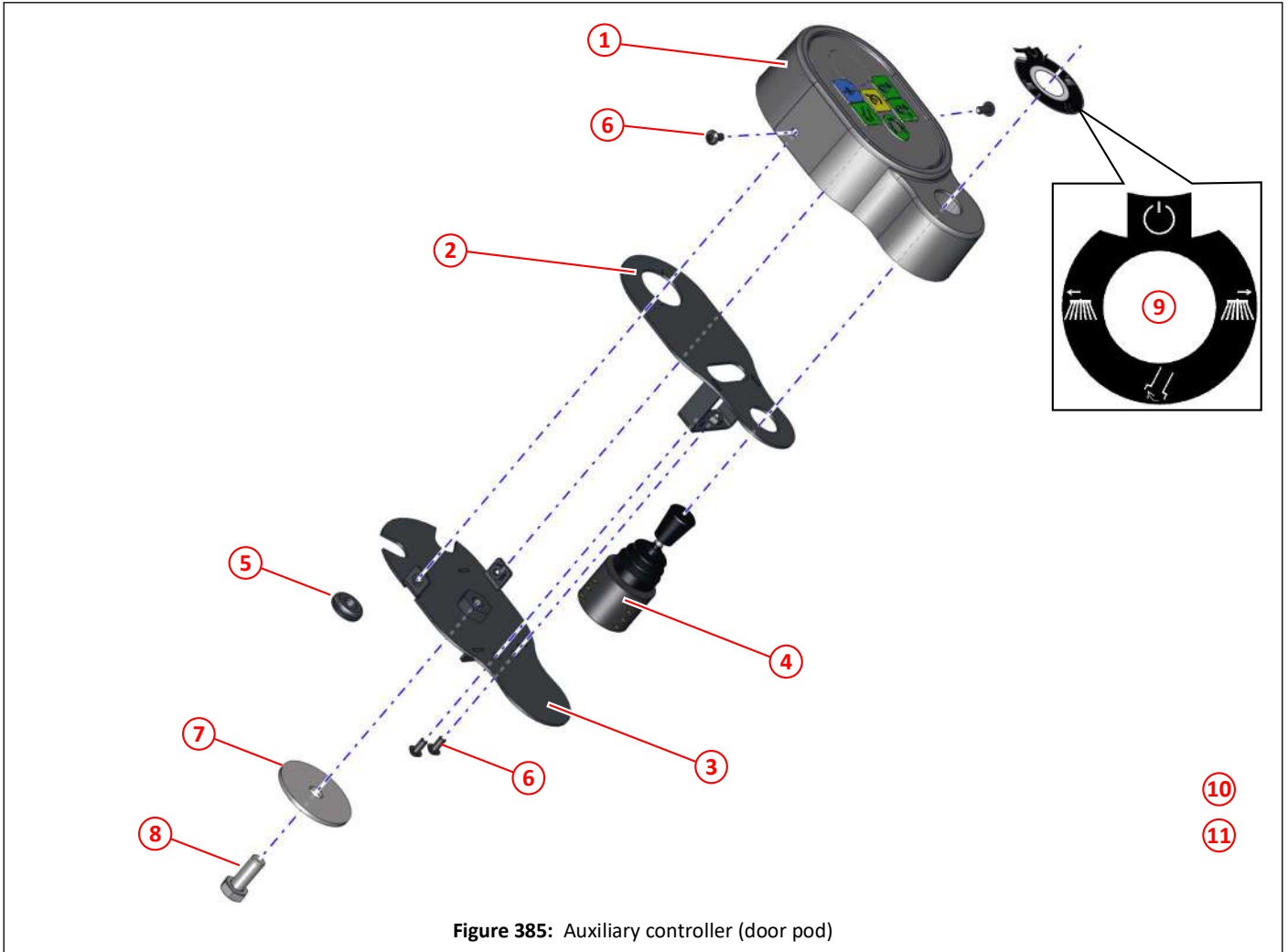

Figure 385: Auxiliary controller (door pod)

Item	Part No	Qty	Description	
①	037608	1	Auxiliary controller (door pod), fascia and keypad	339,420,421,423
②	037057	1	Support plate, auxiliary controller (door pod)V3	
③	037058	1	Backplate, auxiliary controller (door pod)	
④	036873	1	Ergo joystick	
⑤	046259	1	Grommet, semi blind, ø15.9	
⑥	000380	4	Socket button head screw M4 x 10, black	
⑦	037064	1	Door pod lock washer	
⑧	011031	1	Setscrew HT M10 x 25	
⑨	039545	1	Label, ergo joystick	
⑩	036913	1	Loom, auxiliary control panel (door pod)	352
⑪	036915	1	Loom, power/CAN, auxiliary control panel (door pod)	352

Operator screen and camera monitor mounting

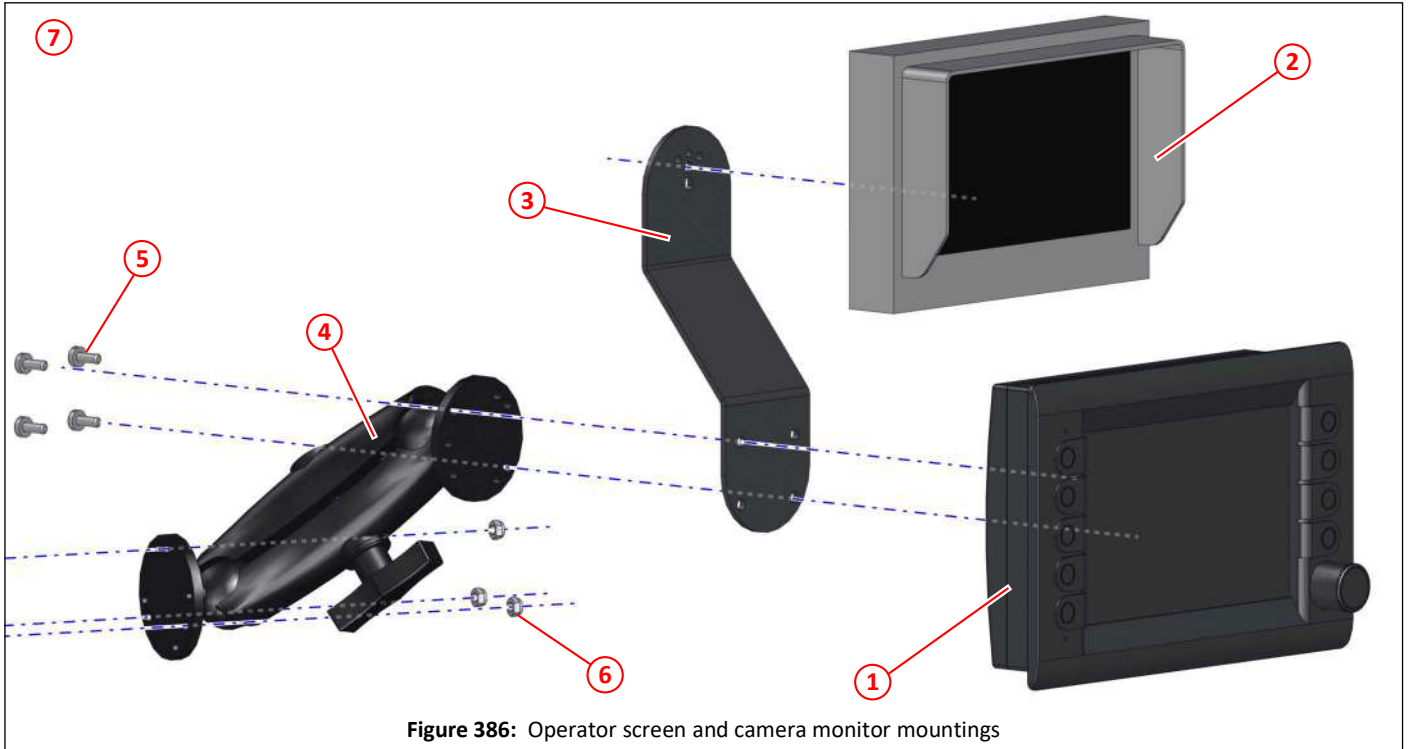

Figure 386: Operator screen and camera monitor mountings

Item	Part No	Qty	Description	
①	051757	1	Operator screen	340,420,421
②	040717 *	1	Camera monitor	341,420,421
③	047903 †	1	Mounting bracket, camera screen	
④	032108	1	Adjustable panel mount, ram	
⑤	100103	4	Pan head POZIDRIV screw M5 x 12	
⑥	000155	3	Nyloc nut M5	
⑦	040349	1	Loom, screen	352

*. Various monitors are available for camera viewing, Please contact Scarab Parts Department.

†. This is an examples bracket for mounting the camera screen. If ordering, then please contact Scarab Parts Department and have your sweeper serial number and type of chassis it is built on available, to ensure correct parts selection.

Main control panel and operator screen mountings

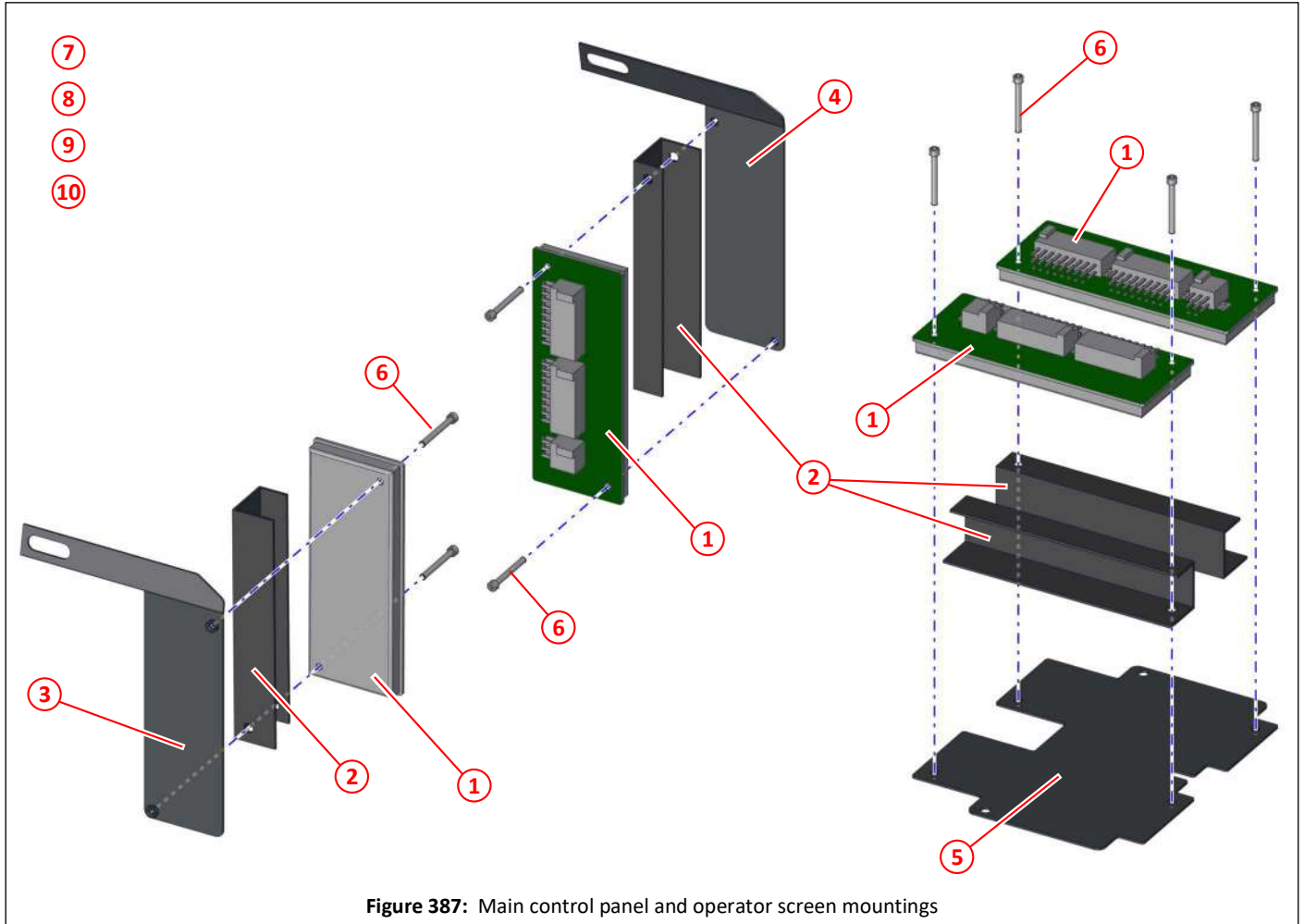

Figure 387: Main control panel and operator screen mountings

Item	Part No	Qty	Description	
①	036799	4	CR2012 cabinet module, (node)	340
②	044290	4	Black plastic extrusion	
③	042041	1	Bracket, node (cabinet module), left hand side	
④	043073	1	Bracket, node (cabinet module), right hand side	
⑤	042045	1	Mounting plate, node (cabinet module)	
⑥	000152	8	Socket cap head screw M4 x 3	
⑦	036913	1	Loom, auxiliary control panel (door pod)	352
⑧	036915	1	Loom, power/CAN, auxiliary control panel (door pod)	352
⑨	036912	1	Loom, main control panel	352
⑩	036914	1	Loom, power/CAN, main control panel	352

Brush pressure valve, gauge and controls

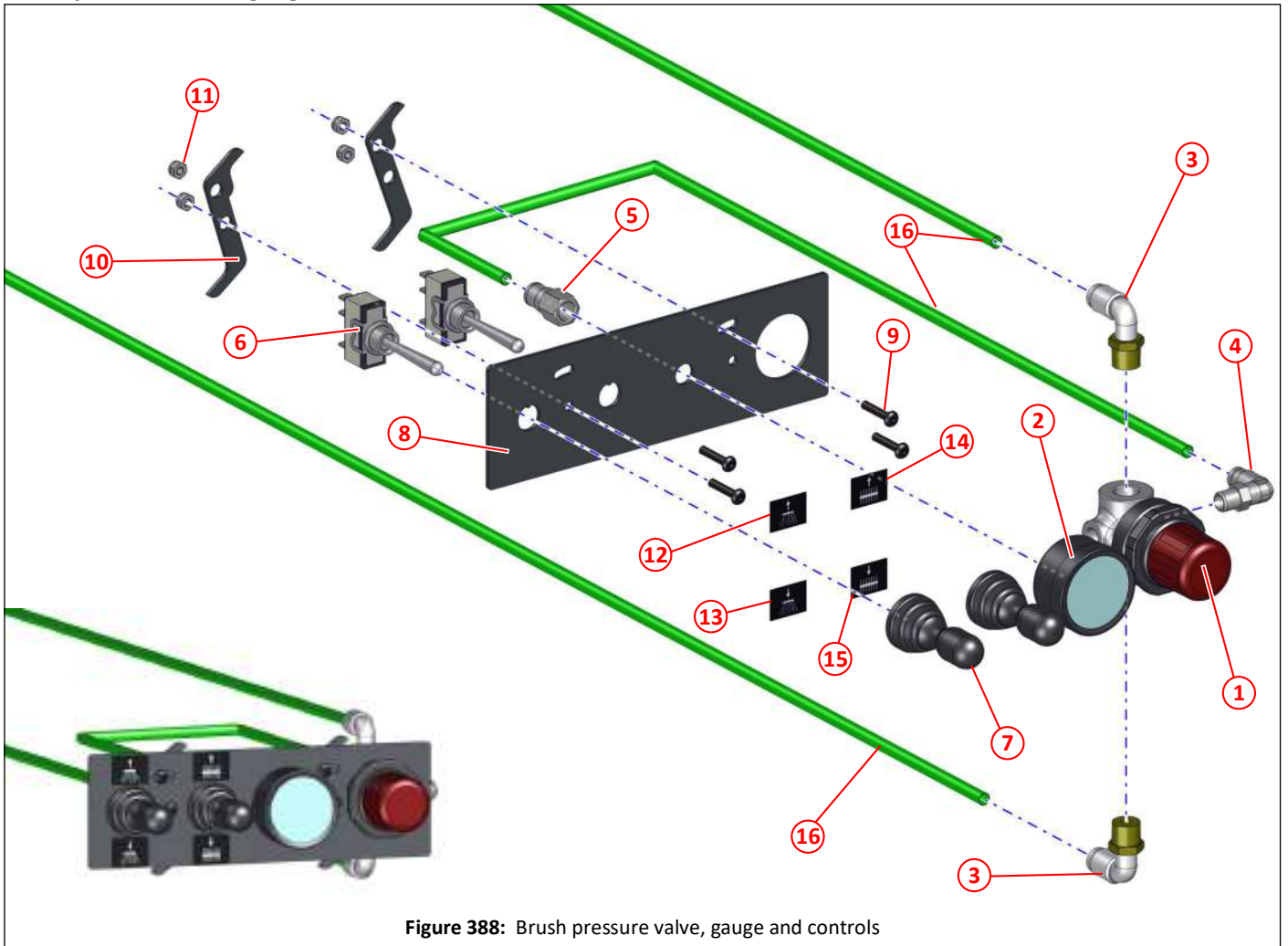

Figure 388: Brush pressure valve, gauge and controls

Item	Part No	Qty	Description
①	023242	1	Mini pressure regulator 0.5 - 3.5bar
②	023246	1	Pressure gauge 0-10bar
③	024646	2	Elbow, swivel, 1/4" BSP x ø6 push in
④	006007	1	Elbow, 1/8" BSP x ø6 push in
⑤	006032	1	Adapter, 1/8" BSP x ø6 push in
⑥	037248	2	Toggle switch on/off/on
⑦	037247	2	Rubber boot for toggle switch
⑧	046628	1	Universal air regulator plate
⑨	000515	4	Socket button head set screw HD M4 x 20 black
⑩	046615	2	Clamp arm for universal air regulator plate
⑪	000134	4	Nyloc nut T M4
⑫	038117	1	Label - Side brush up pressure
⑬	038118	1	Label - Side brush down pressure
⑭	038119	1	Label - Central brush (wide sweep) up pressure
⑮	038120	1	Label - Central brush (wide sweep) down pressure
⑯	024650	3	ø6mm green air pipe, cut to length as required

i Typical items used in cab, actual items will depend on the specification of the sweeper and cab layout. Contact Scarab Parts Department with the sweepers serial number and type of chassis for more information regarding these items.

Remote hopper controller

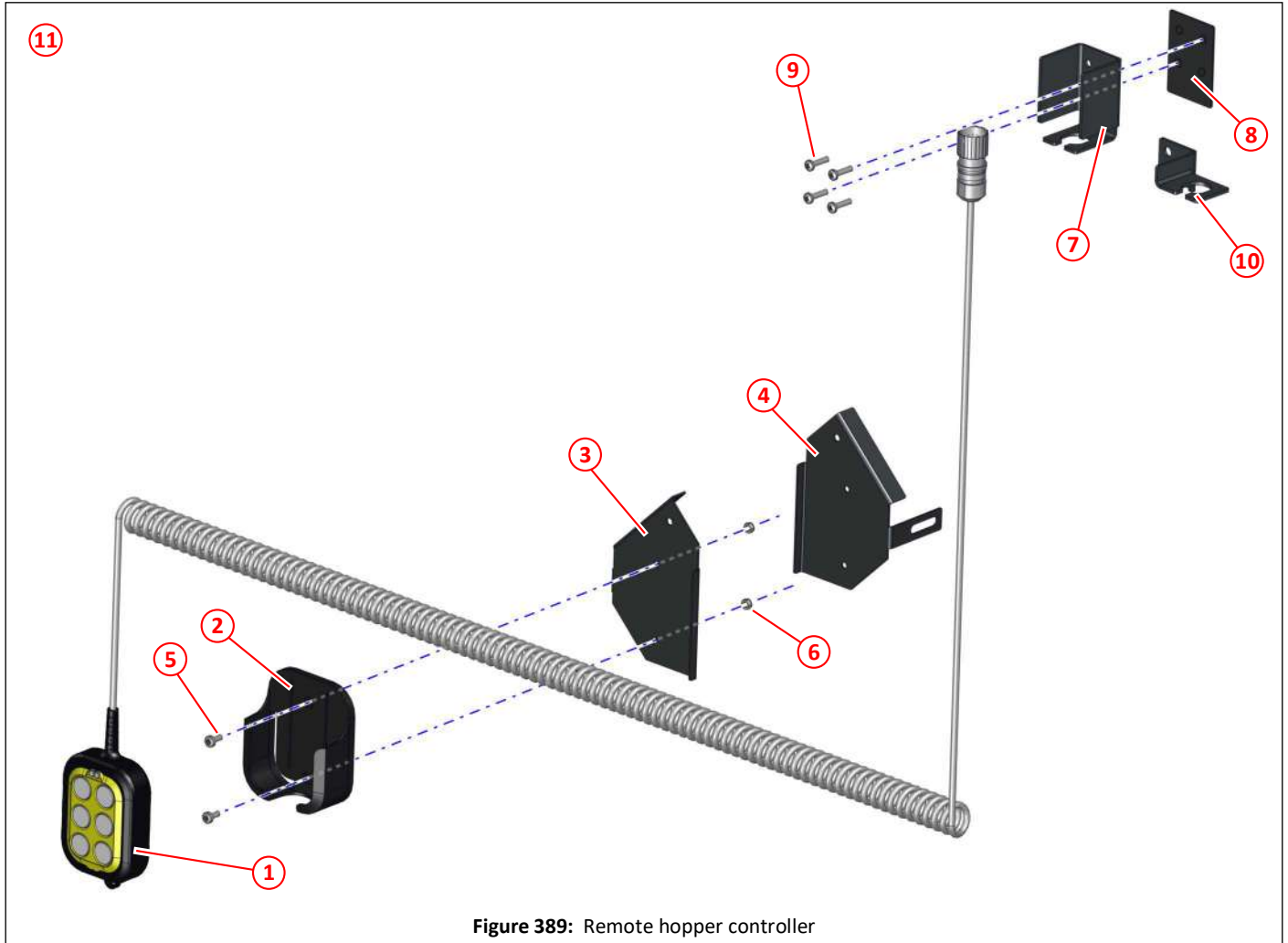

Figure 389: Remote hopper controller

Item	Part No	Qty	Description
①	043688	1	Hopper controller V3 PXL
②	043691	1	Holster, hopper controller V3 PXL
③	037898 *	1	Mounting bracket, hopper controller, left hand
④	037928 *	1	Mounting bracket, hopper controller, right hand
⑤	100103	2	Pan head POZIDRIV screw M5 x 12
⑥	000155	2	Nyloc nut M5
⑦	037299 *	1	Bracket, hopper controller wiring
⑧	038058 *	1	Backplate, hopper controller wiring bracket
⑨	000402	4	Pan head POZIDRIV screw M5 x 20
⑩	037408 *	1	Bracket, hopper controller wiring
⑪	037047	1	Loom, hopper controller

*. These are examples of brackets used to mount the remote controller holster and cable to the chassis or other areas of the cab, if needing to order, then please contact Scarab Parts Department and have your sweeper serial number and type of chassis it is built on available, to ensure correct parts selection.

i Due to the many chassis and variants available it is not practical to list all of the fittings for attaching items to the chassis, please use appropriate fittings and if in any doubt contact Scarab Sweepers for advice.

Other components, cab components

Part No	Description
042049 *	Beacon switch, DAF
038543 *	Beacon switch, Renault
039672	Cable, M12 to USB
037048	Sounder
040717	Camera monitor
041534	Camera splitter
011768	Relay, 10/20 Amp, Beacon(s), 12v
014718	Relay, 10/20 Amp, Beacon(s), 24v
011768	Relay, 10/20 Amp, Ignition, 12v
014718	Relay, 10/20 Amp, Ignition, 24v

*. Switches for other chassis manufacturers please contact Scarab Parts Department.

 For looms and other electrical items in the cab please refer to the "Electrical" section starting on page .

Labels and decals

<i>Description</i>	<i>Page</i>
Warning labels	432
Information labels	433
Information labels	434
Decals and badges	435

Warning labels

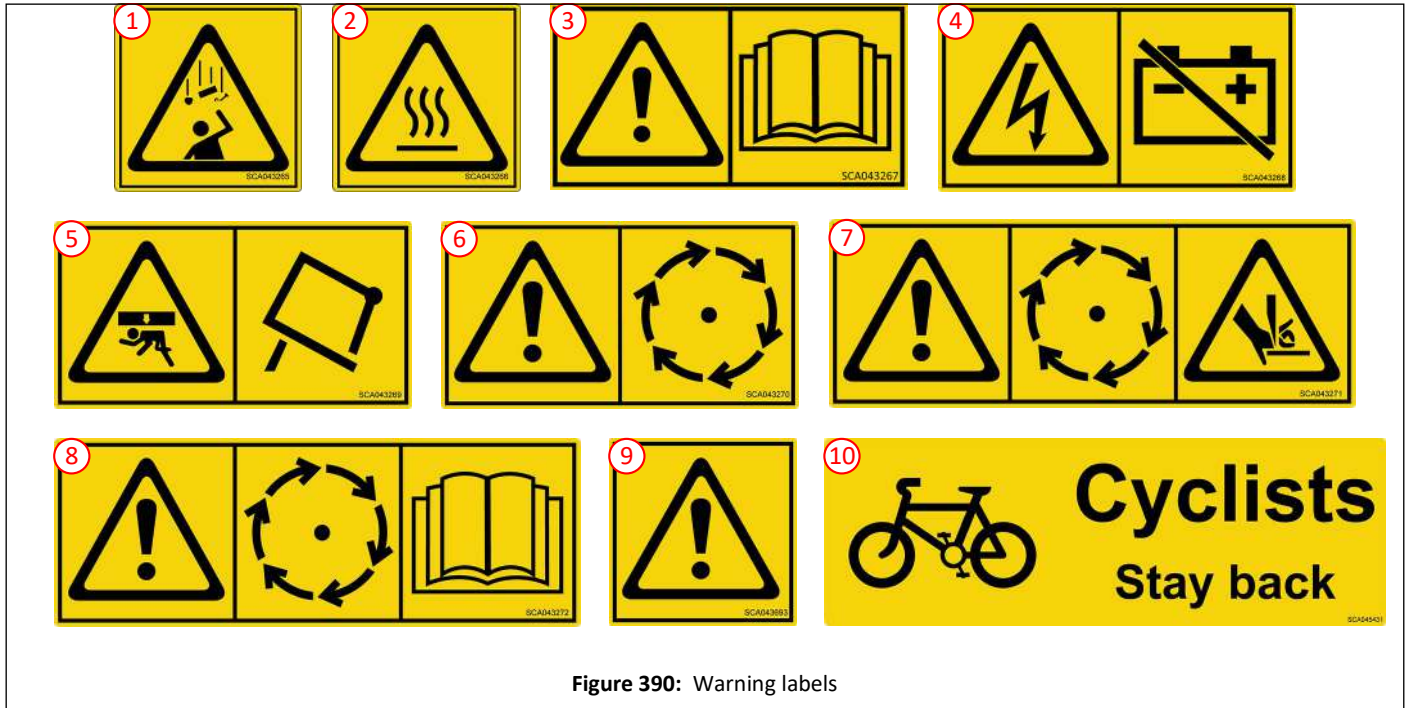

Figure 390: Warning labels

Item	Part No	Description
①	043265	Label - Warning - Debris
②	043266	Label - Warning - Hot surface
③	043267	Label - Warning - Read the manual
④	043268	Label - Warning - Electrical
⑤	043269	Label - Warning - Use hopper prop
⑥	043270	Label - Warning - Rotating parts
⑦	043271	Label - Warning - Rotating parts and trap hazard
⑧	043272	Label - Warning - Rotating parts, read the manual
⑨	043693	Label - Warning
⑩	045491	Label - Warning - Cyclists stay back

i Please note that not all labels will necessarily be on your sweeper. There may also be labels that are specific to your region/country that are not shown in this parts book. Please contact Scarab Parts if you require assistance.

Information labels

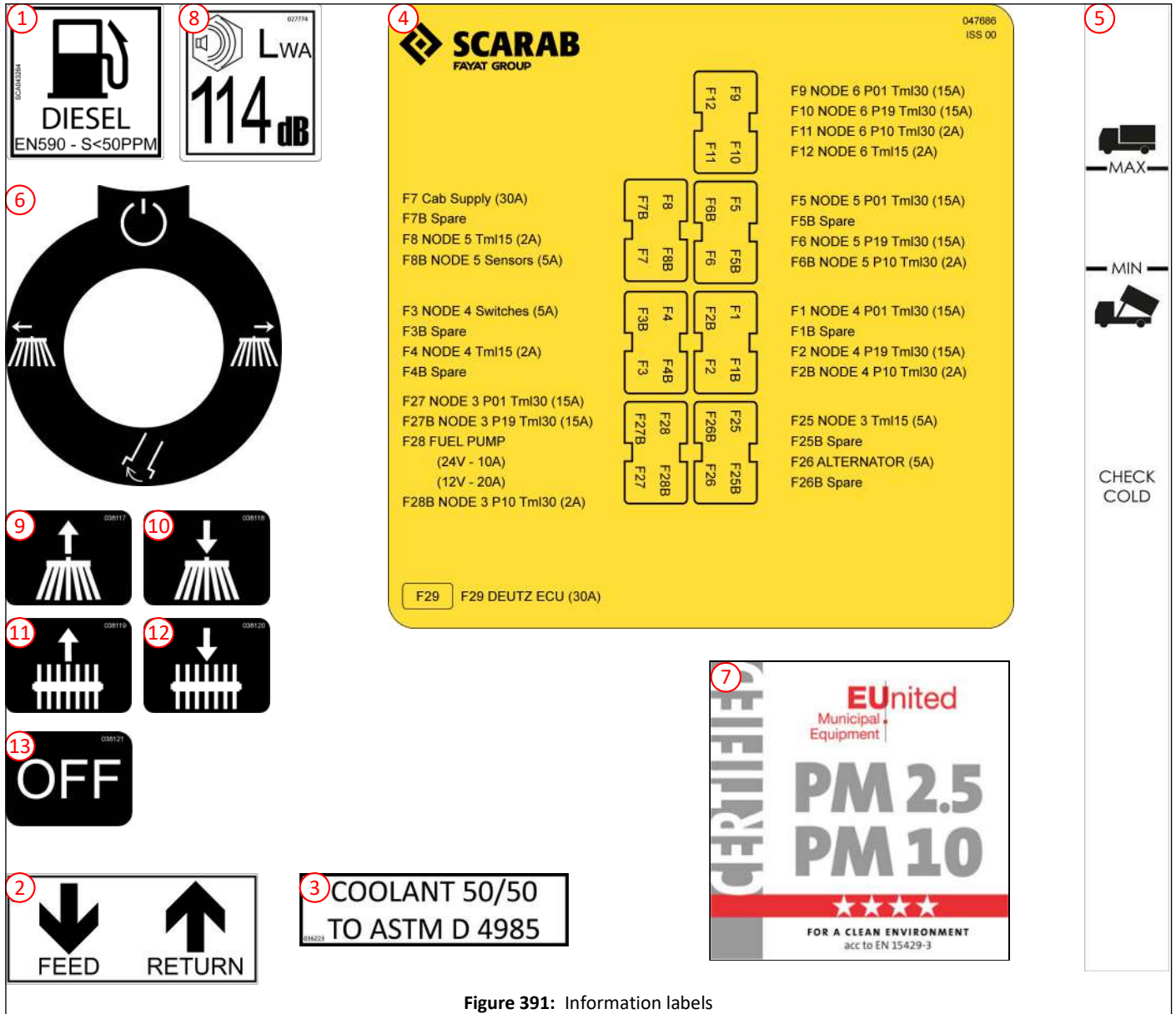

Figure 391: Information labels

Item	Part No	Description
①	043264	Label - Information - Diesel
②	043866	Label - Information - Fuel feed/return
③	036223	Label - Information - Coolant grade
④	043458	Label - Information - Fuses cabinet
⑤	048213	Label - Information - Hydraulic oil level
⑥	039545	Label - Information - Auxiliary control panel joystick
⑦	039869	Label - Information - PM10
⑧	027774	Label - Information - Sound level 114dB
⑨	038117	Label - Information - Side brush up - turn on reduced pressure
⑩	038118	Label - Information - Side brush down - turn on increased pressure -
⑪	038119	Label - Information - Central brush (wide sweep) up - turn on reduced pressure
⑫	038120	Label - Information - Central brush (wide sweep) down - turn on increased pressure
⑬	038121	Label - Information - Brush pressures OFF

Information labels

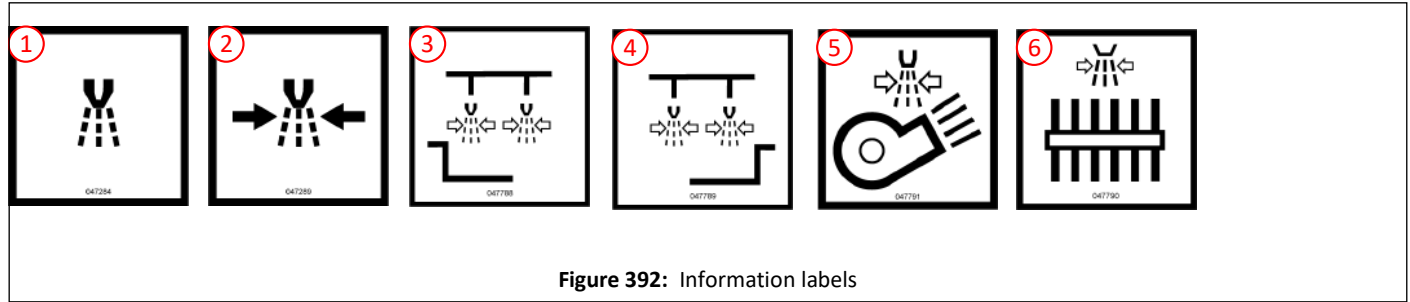

Figure 392: Information labels

Item	Part No	Description
①	047284	Label - Air purge low pressure
②	047289	Label - Air purge high pressure
③	047788	Label - Left Hand HP Spray Bar
④	047789	Label - Right Hand HP Spray Bar
⑤	047790	Label - Fan Wash
⑥	047791	Label - Central brush (wide sweep) HP Water

Decals and badges

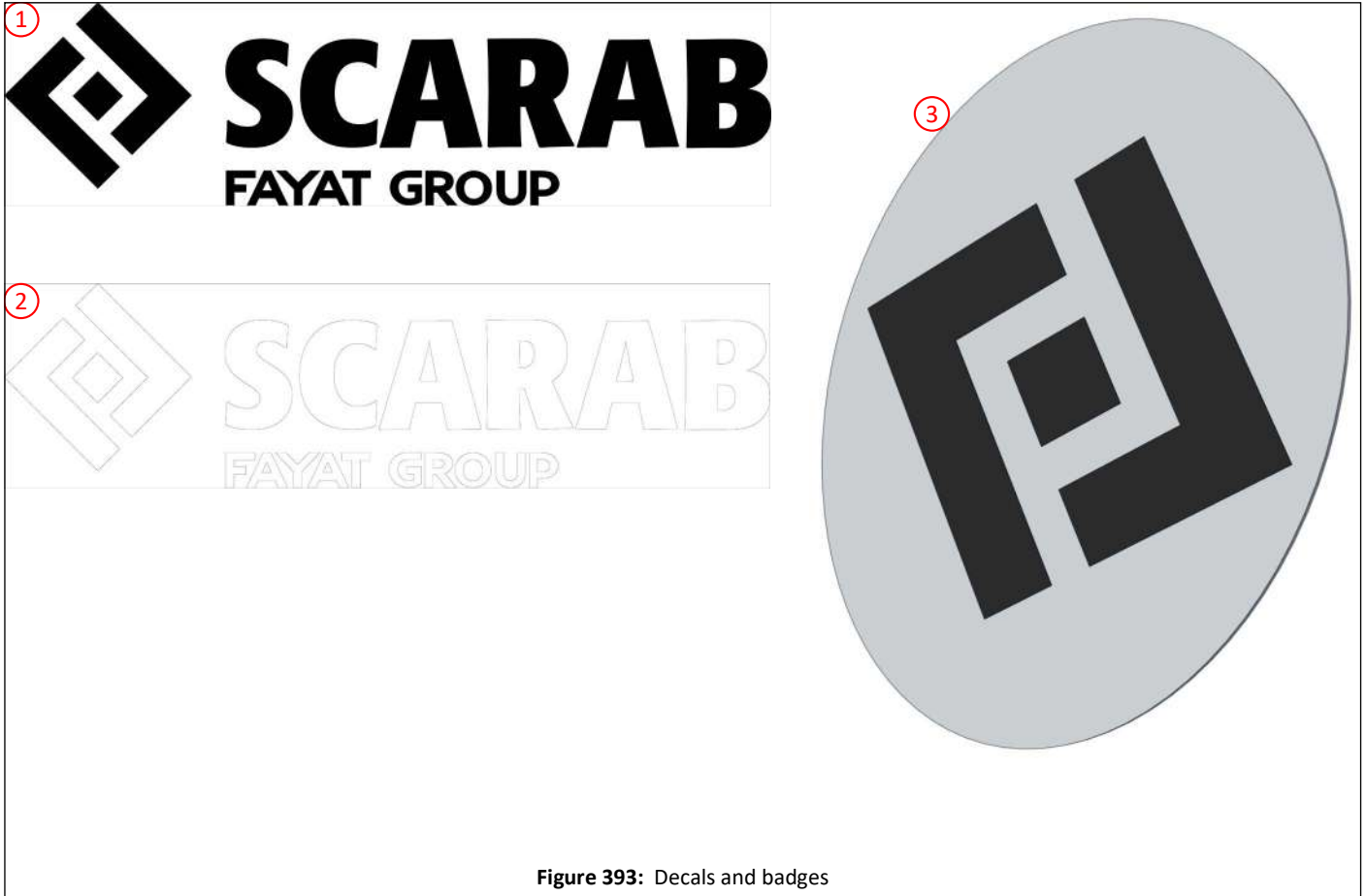

Figure 393: Decals and badges

Item	Part No	Description
①	042983	Scarab Fayat logo, black
②	042983	Scarab Fayat logo, white
③	045762	Fayat logo, domed badge

Multi-lingual glossary

<i>Description</i>	<i>Page</i>
English	458
Français	458
Italiano	458
English	477
Español	477
Svenska	477

English	Français	Italiano
A		
Access	Accès	Accesso
Accessories	Accessoires	Accessori
Accelerator	Accélérateur	Acceleratore
Actuator	Servomoteur	Attuatore
Adapter (adapt)	Adaptateur	Adattatore
Adapter Flange	Adaptateur à bride	Flangia adattatore
Adapter Plate	Adaptateur, à plaque	Piastra adattatore
Adapter, Straight	Adaptateur, droit	Adattatore in linea
Adjuster	Régulateur	Dispositivo di regolazione
Adjuster Kit	Régulateur, kit	Corredo dispositivo di regolazione
Adjuster Valve	Vanne de régulation	Valvola dispositivo di regolazione
Adjustable	Ajustable	Regolabile
Aerial	Antenne	Antenna
Air	Air	Aria
Air Cleaner	Filtre à air	Filtro aria
Air Conditioner	Climatiseur	Condizionatore aria
Air Cylinder	Cylindre d'air	Cilindro aria
Air Filter	Filtre à air	Filtro aria
Air Manifold	Collecteur d'air	Collettore aria
Air Mass Meter	Compteur d'air-massique	Flussometro di massa
Air Feed	Injecteur d'air	Alimentazione aria
Air Chute	Goulotte pneumatique	Lobo aria-aria
Air Outlet	Sortie d'air	Bocca di uscita aria
Air Muffler	Amortisseur d'air	Silenziatore aria
Air Pressure Regulator	Régulateur de pression d'air	Regolatore pressione aria
Air Ram	Vérin pneumatique	Pistone aria
Air Valve	Soupape d'air	Valvola di sfianto
Air Vent Pipe	Tuyau de refoulement d'air	Tubo di sfianto
Alternator	Alternateur	Alternatore
Alternator Interface	Alternateur, interface	Interfaccia alternatore
Aluminium (Alum)	Aluminium (alum)	Alluminio (Allum.)
Anchor	Ancre, dispositif d'ancrage	Ancora
Angle	Angle	Angolo
Antiluce Fastener	Fixation « Antiluce »	Dispositivo di fissaggio Antiluce
Amendment (Amdt.)	Modification (modif.)	Rettifica (rett.)
Amplifier	Amplificateur	Amplificatore
Arrangement	Disposition	Disposizione
Assembly (Assy)	Ensemble	Gruppo
Auto Blanking	Fermeture automatique	Autochiusura
Automatic	Automatique	Automatico

English	Français	Italiano
Auxiliary	Auxiliaire	Ausiliario
Axle	Essieu	Asse
Axle Beam	Essieu, fusée d'	Asta asse
Axle Bolt	Essieu, boulon d'	Bullone asse
Axle Breather	Essieu, reniflard d'	Sfiatatoio asse
Axle Carrier & Tube	Essieu, porte-essieu et tube	Supporto e tubo asse
Axle Front	Essieu, avant	Frontale asse
Axle Rear	Essieu, arrière	Retro asse
Axle Washer	Essieu, rondelle d'	Rondella asse
B		
Back Plate	Socle	Piastra di supporto
Bag	Sac	Borsa
Ball	Bille	Sfera
Ball End	Rotule	Estremità arrotondata
Ball Joint	Joint sphérique	Giunto sferico
Ball Valve	Vanne à boisseau	Valvola a sfera
Bar	Barre	Barra
Basin	Cuvette	Bacino
Battery	Batterie	Batteria
Battery Housing	Batterie, logement de	Sede batteria
Battery Terminals	Batterie, bornes	Terminali batteria
Battery Lead	Batterie, câble	Cavo batteria
Battery Tray	Batterie, plateau	Vassoio portabatteria
Beacon	Gyrophare	Segnale luminoso
Beacon Bar	Barre de gyrophare	Barra segnale luminoso
Beam	Phare	Fascio
Bearing	Roulement, palier	Cuscinetto
Bell Housing	Logement évasé	Sede campanello
Bellows	Soufflet	Soffietto
Belt	Courroie	Cinghia
Black	Noir	Nero
Blanking	Obturation	Tappaggio
Bleeper	Signal	Emettitore di segnali acustici
Blind Rivet	Rivet aveugle	Ribattino con spina inserita
Block	Bloc	Blocco
Blue	Bleu	Blu
Board	Carton	Piastra
Body	Corps	Corpo
Bolt	Boulon	Bullone
hex hd (hexagonal head)	Boulon à tête 6 pans	testa esagonale
skt hd (socket head)	Boulon à tête creuse	brugola

English	Français	Italiano
csk hd (counter-sunk head)	Boulon à tête fraisée	svasato
Boom	Flèche	Braccio
Boost	Suralimenter	Spinta
Bore	Alésage	Camera cilindrica
Boss	Moyeu, bossage	Mozzo
Bottom	Fond	Fondo
Bottle	Bouteille	Flacone
Box	Boîte	Scatola
Brace	Tirant	Braccio
Bracket (Brkt)	Support	Staffa
Brake	Frein	Freno
Brass Wing Nut	Ecrou à oreilles, en laiton	Galletto di ottone
Breather	Reniflard	Sfiatatoio
Broom	Balai	Scopa
Brown	Marron	Marrone
Brush	Brosse	Spazzola
Base	Base	Base
Buffer	Tampon	Respingente
Build	Construire, modèle	Costruzione
Bulb	Ampoule	Lampadina
Bulkhead	Cloison	Paratia
Bumper	Pare-chocs	Paraurti
Bump Stop	Butoir	Respingente
Bungee Cord	Corde « Bungee »	Cavo elastico
Bush	Manchon / Bague	Boccola
Buzzer	Vibreux	Cicalino
Button	Bouton	Pulsante
C		
Cable	Câble	Cavo
Caliper	Calibre	Pinza
Cam Shaft	Arbre à cames	Albero a camme
Camera	Caméra	Camera
Canopy	Auvent / Capot	Tettuccio
Cap	Capuchon	Cappuccio
Capping	Chapeau	Cornice
Carabiner	Carabine	Carabiner
Carrier	Porte, support	Portante
Case	Boîtier	Scatola
Casing	Boîtier	Involucro
Catalogue	Catalogue	Catalogo
Cab	Cabine	Cabina

English	Français	Italiano
Catch	Cliquet, disp. d'arrêt	Fermo
Caution	Notice « attention »	Attenzione
Centre	Centre	Centro
Chain	Chaîne	Catena
Chassis	Châssis	Chassis
Check	Contrôle	Controllo
Check Valve	Soupape d'arrêt / Clapet	Valvola di ritegno
Chute	Goulotte	Scivolo
Circlip	Circlip	Anello elastico
Circuit	Circuit	Circuito
Clamp	Collier	Morsetto
Cleaner	Nettoyage, dispositif de	Detergente
Clevis	Chape	Maniglione
Clip	Pince	Clip
Clutch	Embrayage	Frizione
Coach	Carrosserie	Carrozzeria
Coil	Bobine	Bobina
Collar	Bague de serrage	Piattello
Complete	Complet (complète)	Completo
Components	Composants	Componenti
Compressor	Compresseur	Compressore
Cone	Cône	Cono
Connector	Connecteur	Connettore
Connecting	Connectant	Connessione in corso
Con Rod (Connecting Rod)	Bielle	Biella
Continued (Cont.)	Suite	Continuazione (cont.)
Control (Cntrl)	Contrôle	Controllo (Cntrl)
Controller	Contrôleur	Unità di controllo
Conventional	Conventionnel	Convenzionale
Conversion (Conv)	Conversion	Conversione (Conv)
Cooler	Refroidisseur	Refrigerante
Cooling	Refroidissement	Raffreddamento
Copper	Cuivre	Rame
Core	Ame	Nucleo
Cotter	Goupille	Chiavetta trasversale
Coupling	Raccord / Accouplement	Accoppiamento
Cover	Couvercle	Coperchio
Cowling	Capotage	Cappottatura
Crank-case	Carter-moteur	Basamento
Cranked	Contre-coudé	Gambo piegato
Cross Member	Traverse	Traversa
Crown Wheel	Couronne d'entraînement	Corona dentata

English	Français	Italiano
Curb	Bord, bordure	Bordo
Cylinder	Cylindre	Cilindro
D		
Damper	Amortisseur	Smorzatore
Deflector	Défecteur	Deflettore
Description	Description	Descrizione
Details	Informations	Dettagli
Detergent	Detergent	Detergente
Diagram	Diagramme	Diagramma
Dial	Cadran	Quadrante
Diaphragm	Diaphragme	Diaframma
Diode	Diode	Diodo
Dipped Beam	Feu de croisement	Anabbagliante
Dipstick	Jauge	Asta di livello
Dipstick guide	Jauge, guide de	Guida asta di livello
Dipstick tube	Jauge, tube de	Tubo asta di livello
Directional	Directionnel	Direzionale
Dirt	Impureté	Sporco
Disc / Disk	Disque	Disco
Display	Écran d'affichage	Visualizzatore
Distributor	Distributeur	Distributore
Diverter	Diviseur	Diverter
Door	Porte	Sportello
Double	Double	Doppio
Dowel	Cheville	Perno di riferimento
Down	Bas	Giù
Dowty Seal	Joint « Dowty »	Chiusura ermetica Dowty
Drag Link Tube	Tube de tige directrice	Tirante longitudinale comando sterzo
Drain Plug	Bouchon de vidange	Tappo di scarico
Drive	Entraînement	Trasmissione
Drive Core	Entraînement, âme d'	Nucleo trasmissione
Drive Coupling	Entraînement, raccord d'	Accoppiamento trasmissione
Drive Dog	Entraînement, crabot d'	Innesco trasmissione
Drive Flange	Entraînement, bride d'	Flangia trasmissione
Drive Motor	Entraînement, moteur d'	Motore principale
Drive Pump	Entraînement, pompe d'	Pompa trasmissione
Drive Shaft	Entraînement, arbre d'	Albero comando
Drive Tube	Entraînement, tube d'	Tubo trasmissione
Dual Sweep	Double balayage	doppia spazzata
Dump Valve	Soupape de décharge	Valvola di scarico rapido
Dust	Poussière	Polvere

English	Français	Italiano
E		
Eccentric	Excentrique	Eccentrico
Elbow	Coude	Gomito
Electric	Electrique	Elettrico
Electrical	Electrique	Elettrico
Element	Élément	Elemento
Enclosure	Enceinte	Alloggiamento
End	Extrémité	Estremità
End Plate	Extrémité, plaque d'	Piastra estremità
End Cap	Extrémité, chapeau d'	Cappuccio estremità
Engine	Moteur	Motore
Exchange	Echange	Scambio
Exhaust	Echappement	Scarico
Exhaust Gas Recirculation (EGR)	Recyclage de gaz d'échappement	Ricircolo gas di scarico
Expansion	Dilatation	Espansione
Extended	Dilaté	Esteso
Extension	Extension	Estensione
Extinguisher	Extincteur	Estintore
F		
Fan	Ventilateur	Ventola
Fastener	Fixation	Dispositivo di fissaggio
Feed	Alimentation	Alimentazione
Female	Femelle	Femmina
Filler	Remplisseur	Bocchettone di riempimento
Filter	Filtre	Filtro
Finisher	Finisseur	Finitore
Fire	Feu	Combustione
First	Premier	Primo
Fishtail	Queue de poisson / Cône	Coda di pesce
Fit	Emboîter / Monter	Montaggio
Fitting	Raccord	Montaggio
Fixing	Fixation	Rettifica
Flange	Bride	Flangia
Flap	Volet	Alettone
Flash	Flash	Flash
Flexible (Flexi)	Flexible	Flessibile (flexi)
Floor	Plancher	Pavimento
Floorplate	Plaque de sol	Base pavimento
Flow	Débit	Flusso
Fluid	Fluide	Fluidico

English	Français	Italiano
Flywheel	Volant	Volano
Foam	Mousse	Schiuma
Fog	Brouillard	Nebbia
Foot	Pied	Piede
Forward	Avant	Avanti
Frame	Bâti	Telaio
Front	Avant	Anteriore
Fuel	Carburant	Combustibile
Function	Fonction	Funzione
Fuse	Fusible	Fusibile
G		
Gain	Gain	Guadagno
Galvanised	Galvanisé	Zincato
Gantry	Portique	Cavalletto
Gas	Gaz	Gas
Gas Strut	Jambe à gaz	Puntone gas
Gasket	Garniture d'étanchéité	Guarnizione
Gauge	Manomètre	Calibro
Gauze	Gaze	Garza
Gear	Engrenage	Ingranaggio
Geared	A engrenages	Ingranato
Gearbox	Boîte de vitesses	Scatola del cambio
General	Général(e)	Generale
Glass	Verre	Vetro
Glow Plug	Bougie de préchauffage	Spina a incandescenza
Gobbler (Nozzle Tilt)	Gobbler (Inclinaison d' Embout)	Gobbler (Ugello Inclinazione)
Grab	Grappin	1. Estrattore a pinza (n)
Grease	Graisse	Grasso
Greaser	Graisneur	Ingrassatore
Green	vert	Verde
Grey	gris	Grigio
Grill	gril	Griglia
Grip	manche	1. Presa (n)
Grub Screw	vis sans tête	Vite di riferimento
Grommet	virole	Anello di tenuta
Guard	Carter de protection	Riparo
Guide	Guide	Guida
H		
Hand	Côté	Mano
Hand Primer	Pompe à main, dispositif de	Pompetta di adescamento a mano

English	Français	Italiano
Hand Wash	Lavage à main	Lavaggio a mano
Handbrake	Frein à main	Freno a mano
Handle	Poignée	Maniglia
Hanger	Suspension	Supporto pendente
Harness	Harnais	Cablaggio
Head	Tête	Testa
Headlamp	Phare	Faro
Heat	Chaleur	Calore
Heatshield	Bouclier thermique	Scudo termico
Heater	Chauffage	Riscaldatore
High Pressure	Haute pression	Alta pressione
Hi Tip	Bennage en hauteur	Punta alta
Hinge	Charnière	Cerniera
Hinged	Charnière, à	Incernierato
Holder	Porte-outil	Staffa di supporto
Hooks	Crochets	Ganci
Hopper	Trémie	Serbatoio con scarico sul fondo
Horn	Avertisseur sonore	Avvisatore acustico
Hose	Tuyau flexible	Tubo flessibile
Hose Tail	Tuyau flexible, bout de	Raccordo tubo flessibile
Hot	Chaud	Caldo
Hour Meter	Compteur horaire	Contaore
Housing	Logement	Alloggiamento
Hub	Manchon	Mozzo
Hydraulic	Hydraulique	Idraulico
Hydrant	Bouche d'incendie	Idrante
Hydrant Filler	Bouche d'incendie, disp. de remplissage	Filtro idrante
Hydrant Hose	Bouche d'incendie, tuyau souple	Tubo idrante
Hydrostatic	Hydrostatique	Idrostatico
I		
Identification	Identification	Identificazione
Idle	Inactif / Ralenti	Inattivo
Ignition (Ign)	Contact	Accensione (Acc)
Illuminated	Eclairé	Illuminato
Illustrated	Illustré	Illustrato
Illustration	Illustration	Illustrazione
Impellor	Rotor / Turbine	Girante
Inclusive	Compris	Inclusivo
Information (Info)	Informations	Informazioni (Info)
In	Entré	Dentro
Inlet	Entrée	Ammissione

English	Français	Italiano
Inlet Cone	Entrée, cône d'	Cono di ammissione
Inlet Pipe	Entrée, tuyau d'	Tubo di ammissione
Injection Pump	Pompe d'injection	Pompa d'iniezione
Injector	Injecteur	Iniettore
Injector Pipe	Tuyau d'injection	Tubo iniettore
Input	Entrée	Ingresso
Inseal Strip	Bande d'étanchéité	Guarnizione sigillante
Insert	Insert	Inserto
Insertion	Insertion	Inserimento
Installation	Installation	Installazione
Instrument	Instrument	Strumento
Insulator	Isolateur	Isolante
Inter Cooler	Refrroidisseur intermédiaire	Refrigeratore intermedio
Interior	Intérieur	Interno
Interim	Intérimaire	Interim
Internal	Interne	Interno
Item	Article	Articolo
J		
Jet	Jet	Getto
Joint	Joint	Giunto
Joystick	Joystick	Joystick
Jubilee Clip	Pince crocodile	Fermaglio Jubilee
Junction	Jonction	Incrocio
K		
Key	Clé	Chiave
Key Switch	Interrupteur à clé	Interruttore a chiavetta
Kerb	Bordure	Bordo (as in pavement)
King Pin	Axe-pivot	Perno di sterzaggio
King Post	Poinçon de façade	Puntone di sostegno
Kit	Kit	Corredo
Knob	Bouton	Manopola
L		
Label	Etiquette	
Lamp	Lampe	Lampada etichetta
Work Lamp	Lampe de travail	Lampada da lavoro
Head Lamp	Projecteur	Faro
Side Lamp	Lampe latérale	Luce di posizione
Lance	Lance	Lancia

English	Français	Italiano
Lap Joint	Joint à recouvrement	Giunto a sovrapposizione
Large	Grand	Grande
Latch	Verrou	Serratura
Lead	Fil	Cavo
L.E.D. (Light Emitting Diode)	Diode électroluminescente	LED (Diodo a emissione luminosa)
Leash	Laisse	Maglia
Left	Gauche	Sinistra
Left Hand Drive (LHD)	Conduite à gauche	Guida a sinistra (LHD)
Leg	Jambe	Gamba
Length	Longueur	Lunghezza
Lens	Objectif	Lente
Level	Niveau	Livello
Lever	Levier	Leva
Lid	Couvercle	Coperchio
Lift	Ascenseur	Sollevare
Lifting	Levage	Sollevamento
Light	Feux	Luce
Side Light	Feux latéraux	Luce di posizione
Head Light	Phare	Faro
Rear Light	Feu arrière	Fanale di coda
Brake Light	Feux stop	Luce freno
Interior Light	Eclairage intérieur	Luce abitacolo
Fog Light	Feu antibrouillard	Faro antinebbia
Linch Pin	Axe d'essieu	Acciarino
Lining	Revêtement	Rivestimento interno
Link	Maillon	Articolazione
Linkage	Tringlerie	Sistema di leve
Litre	Litre	Litro
List	Liste	Lista
Load	Charge	Carico
Located	Situé	Posizionato
Lock	Verrou	Fermo
Locknut	Ecrou de blocage	Controdado
Locker	Armoire	Armadietto
Locking	Verrouillage	Serraggio
Long	Long	Lungo
Loom	Métier	Cablaggio
Loop	Boucle	Circuito elettrico ad anello
Low Pressure	Basse pression	Bassa pressione
Lower	Baisser	Inferiore
Lubricant	Lubrifiant	Lubrificante
Lubrication	Lubrification	Lubrificazione

English	Français	Italiano
M		
Machine	Machine	Macchina
Magnet	Aimant	Magnete
Magnetic	Magnétique	Magnetico
Main	Principal(e)	Principale
Male	Mâle	Maschio
Management	Gestion	Gestione
Manifold	Collecteur	Collettore
Manual	Manuel	Manuale
Manufactured	Fabriqu�	Fabbricato
Marker Lamp	Lampe signal	Lampada di segnalazione
Master	Ma�tre	Principale
Master Cylinder	Ma�tre-cylindre	Cilindro principale
Maximum (Max)	Maximum (maxi)	Massimo (max.)
Mesh	Tamis	Maglia
Metal	M�tal	Metallo
Meter	M�tre	Calibro
Micro Switch	Micro-contact	Microinterruttore
Minimum (Min)	Minimum (mini)	Minimo (min.)
Mirror	Miroir	Specchio
Miscellaneous	Divers	Miscellanea
Modified	Modifi�	Modificato
Module	Module	Modulo
Monitor	Moniteur	Monitor
Motor	Moteur	Motore
Mount	Monture	Montaggio
Mounted	Mont�	Montato
Mounting	Ch�ssis / Support	Montaggio
Mud Flaps	Bavettes de garde-boue	Paraspruzzi
Mud Guard	Garde-boue	Parafango
Muffler	Amortisseur	Marmitta
Multi Function	Multifonctions	Multifunzionale
N		
N/A (Not Applicable)	S/O (sans objet)	N/D (Non disponibile)
Narrow	Etroit	Stretto
Near side	C�t� trottoir	Lato guida
Negative	N�gatif	Negativo
Neutral	Neutre	Neutro
New	Nouveau (nouvelle)	Nuovo
Nipple	Manchon	Raccordo filettato

English	Français	Italiano
No	Non	N. (Numero)
Non Return	Anti-retour	Non ritorno
Normal	Normal	Normale
Note	Note	Nota
Nozzle	Embout / Buse	Ugello
Number	Numéro	Numero
Numerical	Numérique	Numerico
Nut	Ecrou	Dado
Nyloc Nut	Ecrou « Nyloc »	Dado Nyloc
Hex Nut	Ecrou hexagonal	Dado a testa esagonale
Plain Nut	Ecrou normal	Dado liscio
Self Locking Nut	Ecrou autobloquant	Dado autobloccante
Thin Nut	Ecrou mince	Dado sottile
Nylon Tube	Tube de nylon / Nylon, tube de	Tubo di nylon
O		
Obsolete	Périmé	Obsoleto
Off	Arrêt	1. Spento 2. Inattivo
Off Side	Côté route	Lato passeggero
Oil	Huile	Olio
Olive	Olive	Oliva
On	Marche	1. Acceso 2. Attivo
Open	Ouvrir	Aprire
Opened	Ouvert(e)	Aperto
Opening	Ouverture	Apertura
Operating	Fonctionnement, de	Operativo
Option	Option	Opzione
Optional	Optionnel(le)	Opzionale
Orange	Orange	Arancione
Original	Original	Originale
O Ring	Joint torique	Anello di tenuta toroidale
Out	Sorti(e)	1. Fuori 2. Esterno
Outer	Extérieur(e)	Esterno
Outlet	Sortie	Sbocco
Output	Production	Uscita
Overhead	Surélevé	in testa
Overload	Surcharge	Sovraccarico
P		
Packer	Garniture d'étanchéité	Imballatore
Panel	Panneau	Pannello
Part	Pièce	Ricambio

English	Français	Italiano
Pedal	Pédale	Pedale
Pick-up	Prendre / en lever	Ripresa
Pilot (pressure)	Pilote	Pilota
Pin	Cheville	Perno
Pinion	Pignon	Pignone
Pink	Rose	Rosa
Pipe	Tuyau	Tube
Piping	Tuyauterie	Tubazione
Piston	Piston	Pistone
Pivot	Pivot	Perno di testa
Plastic	Plastique, matière	Plastica
Plate	Plaque	Piastra
Plinth	Plinthe	Base
Plug	Bouchon / Prise électrique	Spina
Point	Point	Punto
Poppet Valve	Soupape / Clapet	Valvola supporto verticale
Ports	Orifices	Porte
Position	Position	Posizione
Positioned	Positionné(e)	Posizionato
Post	Montant	Montante
Potentiometer	Potentiomètre	Potenziometro
Power	Puissance	Potenza
Pneumatic (See Also Air)	Pneumatique	Pneumatico (vedi anche Aria)
Pressure	Pression	Pressione
Primer	Amorce / Apprêt	Innesco
Production	Production	Produzione
Prop	Support	Puntello
Propshaft	Arbre de transmission	Albero puntello
Pull	Tirer	Tirare
Pulley	Poulie	Puleggia
Pulsation	Pulsation	Pulsazione
Pulse	Impulsion	Polso
Pump	Pompe	Pompa
Purple	Violet	Porpora
Q		
Quick Release	Rapide, raccord	Disinnescio rapido
R		
Radiator (Rad)	Radiateur	Radiatore (rad)
Raise	Soulever	Sollevare
Raised	Soulevé(e)	Sollevato

English	Français	Italiano
Ram	Vérin	Pistone
Ratio	Rapport	Rapporto
Rear	Arrière	Retro
Red	Rouge	Rosso
Reducer	Réducteur	Riduttore
Reducing	Réduction, de	Riduzione
Reduction	Roue / Enrouleur	Riduzione
Reel	Bobine	Bobina
Refer	Voir	Riferimento
Refill	Remplir	Rabbocco
Regulator	Régulateur	Regolatore
Related	Relatif	Correlato
Relay	Relais	Relè
Release	Dégagement	Disinnesco
Relief Valve	Soupape de sûreté	Valvola di sfogo
Remote	A distance / Distance, à	Remoto
Repair	Réparation	Riparazione
Replacement	Remplacement	Sostituzione
Resister	Résistance	Resistore
Refill	Remplir	Rabbocco
Regulator	Régulateur	Regolatore
Related	Relatif	Correlato
Relay	Relais	Relè
Release	Dégagement	Disinnesco
Relief Valve	Soupape de sûreté	Valvola di sfogo
Remote	A distance / Distance, à	Remoto
Repair	Réparation	Riparazione
Replacement	Remplacement	Sostituzione
Resister	Résistance	Resistore
Restrictor	Restriction	Limitatore
Retainer	Retenue, dispositif de	Fermo
Retaining	Retenue, de	Sostegno
Return	Retour	Ritorno
Reverse	Inverse	Retromarcia
Reversing	Recul	Inversione di marcia
Right	Droite	Destra
Right Hand Drive (RHD)	Conduite à droite	Guida a destra
Rim	Jante	Bordo
Ring	Bague	Anello
Road	Route	Strada
Rod	Tige	Asta
Rolling	Roulant, de roulement	Rotolante

English	Français	Italiano
Rotary	Rotatif	Rotante
Rotate	Tourner	Ruotare
Rotating	Tournant	Rotante
Rotation	Rotation	Rotazione
Rubber	Caoutchouc	Gomma
S		
Safety	Sécurité	Sicurezza
Scraper	Racleur	Raschietto
Screen	Ecran	Schermo
Screw	Vis	Scheggia
Hex hd (hexagonal head)	Vis à tête 6 pans	Testa esagonale
skt hd (socket head)	Vis à tête creuse	Brugola
csk hd (counter-sunk head)	Vis à tête fraisée	Svasata
Seal	Garniture d'étanchéité	Chiusura ermetica
Sealant	Etanchéifiant	Materiale di tenuta
Sealing	Etanchéité, d'	Sigillante
Seat	Siège	Sedile
Securing	Fixation, de	Fissaggio
Selector Shaft	Levier de commande	Albero selettore
Self Tapping	Auto-taraudeur	Autofilettante
Sender	Expéditeur / Transmetteur	
Sensor	Capteur	Sensore
Separation	Séparation	Separazione
Serial	Série, de	Seriale
Service Exchange (S/EX)	Echange standard	Scambio di servizio
Set screw	Vis de calage	Vite di fermo
Shaft	Arbre	Albero
Shells	Calandres	Gusci
Shield	Ecran	Scudo
Shim	Cale	Zeppa
Shock Absorber	Amortisseur	Ammortizzatore
Shoe	Patin	Scarpa
Short	Court(e)	Ganascia
Shovel	Pelle	Pala
Side Access Door	Porte d'accès latéral	Sportello accesso laterale
Sight	Vue	Mirino
Silencer	Silencieux	Silenziatore
Silicon	Silicone	Silicone
Single	Simple	Singolo
Skirt	Jupe	Bordatura
Slate	Ardoise	Ardesia

English	Français	Italiano
Sleeve	Gaine	Manicotto
Slew	Pivoter	Ruotare
Slewing	Orientation	Rotazione
Sliding	Coulissant	Slittamento
Slotted	Fente, A	Sfinestrato
Small	Petit(e)	Piccolo
Socket	Prise	Presa
Solenoid	Solénoïde / Noyau	Solenoid
Spacer	Pièce d'espacement	distanziatore
Spare	Rechange, pièce de	ricambio
Speakers	Haut-parleurs	altoparlanti
Special	Spécial(e)	speciale
Speed	Vitesse	velocità
Spherical	Sphérique	sferico
Spigot	Goujon / Tube de jonction	zipolo
Spindle	Broche	mandrino
Splined	Cannelé	linguetta
Split Pin	Goupille fendue	coppiglia
Splitter	Répartiteur	diviso
Spray	Pulvérisateur	spray
Spring	Ressort	molla
Stabiliser	Stabilisateur	stabilizzatore
Stabilising	Stabilisation	stabilizzante
Stack	Pile	pila
Standard	Standard	standard
Standpipe	Colonne montante	colonna in aumento
Starter	Démarrreur	starter
Steel	Acier	acciaio
Steering	Direction	lo sterzo
Stem	Tige	Guarnizione
Stiffener	Raidisseur	rinforzo
Stop	Arrêt	fermare
Storage	Rangement	conservazione
Stowage	Arrimage	stivaggio
Straight	Droit(e)	dritto
Strap	Attache	cinghia
Strip	Bande	Cintura
Strut	Jambe	il supporto
Stub	Souche	mozzicone
Stud	Goujon fileté	il perno
Studded	Barrettes, A	costellato
Studding	Colombage	coltellaccio

English	Français	Italiano
Sub Frame	Faux-châssis	sottotelaio
Suction Fan	Turbine d'aspiration	turbina di aspirazione
Suction Nozzle	Buse d'aspiration	ugello di aspirazione
Sump	Carter	i carter
Supply	Fourniture	fornitura
Support	Support	supporto
Suppression	Suppression	repressione
Suspension	Suspension	sospensione
Sweep	Balayage	spazzare
Sweeping	Balayant, de balayage	Formatura a sagoma
Swing	Balancement	Oscillazione
Switch / Switches	Interrupteur / Interrupteurs	Interruttore / Interruttori
Swivel	Pivotant	Parte girevole
System	Système	Sistema
T		
Tab Washer	Rondelle à languettes	Rondella di sicurezza
Tachograph	Tachygraphe	Tachigrafo
Tachometer	Tachymètre	Tacometro
Tandem	Tandem	Tandem
Tank	Réservoir	Serbatoio
Tapered	Conique	Conico
Taper Lock	Verrou conique	Serratura conica
Tee Key	Clé à béquille	Chiave a T
Temperature (Temp)	Température (temp.)	Temperatura (Temp)
Template	Gabarit	Sagoma
Tensioner	Tendeur	Tensiometro
Terminal	Borne	Terminale
Test	Test	Test
Thermostat	Thermostat	Termostato
Thick	Epais	Spesso
Thimble	Dé	Bussola
Thin	Mince	Sottile
Throttle	Accélérateur	Farfalla
Thrust	Poussée	Spinta
Tie Rod	Tirant	Tirante
Tilt	Inclinaison	Inclinazione
Tilting	Inclinable	Inclinazione
Timer	Minuterie	Timer
Timing	Minutage	Temporizzazione
Toggle	Bascule	Ginocchiera
Tool	Outil	Attrezzo

English	Français	Italiano
Toolbox	Boîte à outils	Cassetta attrezzi
Toothed	Dentelé(e)	Dentato
Top	Dessus	Cima
Tow	Remorquer	Rimorchio
Tow Ball	Boule de remorquage	Sfera rimorchio
Tow Bar	Barre de remorquage	Barra rimorchio
Tow Point	Point de remorquage	Punto di rimorchio
Track Rod	Barre d'accouplement	Barra di accoppiamento
Trailer	Remorque	Rimorchio
Transfer Gearbox	Boîte de transfert intermédiaire	Scatola del cambio a trasferimento
Transmission	Transmission	Trasmissione
Travel	Course	Corsa
Trunking	Jonction	Circuito di collegamento
Trunnion	Tourillon	Perno di articolazione
Tube	Tube	Tubo
Tubing	Tubage	Tubazione
Turbocharger (Turbo)	Turbocompresseur	Turbocompressore
Twin	Jumelé	Gemello
Type	Type	Tipo
Typical	Typique	Tipico
Tyre	Pneu	Pneumatico
U		
Uncompressed	Non comprimé	Decompresso
Underside	Dessous	Disotto
Universal Joint (U/J)	Joint universel / Croisillon	Giunto universale
Union	Raccord	Unione
Unit	Unité	Unità
Un-Loader	Déchargeur	Scaricatore
Up	Dessus	Su
Update	Mise à jour	Aggiornamento
Usage	Utilisation	Utilizzo
V		
Valve	Vanne / Soupape	Valvola
Variant	Variante	Variante
Vehicle	Véhicule	Veicolo
Voltage	Tension	Voltaggio
W		
Wander Hose	Flexible aspirateur	Tubo flessibile mobile

English	Français	Italiano
Warning	Avertissement	Avvertenza
Washer	Rondelle	Rondella
Water	Eau	Acqua
Wear	Usure	Usura
Weed Ripper	Désherbage, dispositif de	Sarchiatore
Welded	Soudé	Saldato
Wheel	Roue	Ruota
White	Blanc(he)	Bianco
Wide Sweep	Balayage large	Curvatura larga
Windscreen	Pare-brise	Parabrezza
Wiper	Essuie-glace	Tergicristallo
Wires	Câblage	Fili
Wiring – black, blue, brown, green, grey, orange, pink, purple, red, white yellow	Câblage – noir, bleu, marron, vert, gris, orange, rose, violet, rouge, blanc jaune	Cablaggio Nero, Blu, Marrone, Verde, Grigio, Arancione, Rosa, Porpora, Rosso, Bianco Giallo
Work Light	Lampe de travail	
X		
Xenon	Xénon	Xenon
Y		
Yellow	Jaune	Giallo

English	Español	Svenska
A		
Access	Acceso	Tillgång
Accessories	Accesorios	Tillbehör
Accelerator	Acelerador	Gaspedal
Actuator	Accionador, servomotor	Aktiverare
Adaptor (adapt)	Adaptador (Adapt.)	Övergång
Adapter Flange	Brida del adaptador	Övergångsfläns
Adaptor Plate	Disco del adaptador	Övergångsplatta
Adaptor, Straight	Tramo recto del adaptador	Rak övergång
Adjuster	Regulador	Justering
Adjuster Kit	Juego regulador	Justeringssatts
Adjuster Valve	Válvula del regulador	Ventiljustering
Adjustable	Ajustable	Justerbar
Aerial	Antena	Antenn
Air	Aire	Luft
Air Cleaner	Purificador de aire	Luftrenare
Air Conditioner	Aire acondicionado	Luftkonditionering
Air Cylinder	Cilindro de aire	Luftcylinder
Air Filter	Filtro de aire	Luftfilter
Air Manifold	Distribuidor de aire	Luftfördelare
Air Mass Meter	Medidor de masa de aire	Luftmätare
Air Feed	Inyector de aire	Luftförsörjning
Air Air Chute	Conducto neumático	Dränering
Air Outlet	Salida de aire	Överskottsluft
Air Muffler	Silenciador de aire	Luftljuddämpare
Air Pressure Regulator	Regulador de presión del aire	Luftregulator
Air Ram	Aire a presión	Luftkolv
Air Valve	Válvula de aire	Luftventil
Air Vent Pipe	Tubería del sistema de ventilación	Luftventilsrör
Alternator	Alternador	Generator
Alternator Interface	Acoplamiento del alternador	Generatorfäste
Aluminium (Alum)	Aluminio (Alum.)	Aluminium
Anchor	Anclaje	Ankare
Angle	Ángulo	Vinkel
Antiluce Fastener	Elemento de sujeción "Anti-luce"	Låsbeslag(sidodörr)
Amendment (Amdt.)	Corrección (Correc.)	Rättelse/förbättring
Amplifier	Amplificador	Elektrisk förstärkare
Arrangement	Disposición	Arrangemang
Ashtray	Cenicero	Askkopp
Assembly (Assy)	Conjunto (Conj.)	Sätta ihop

English	Español	Svenska
Auto Blanking	Borrado automático	Automatisk stängning
Automatic	Automático	Automatisk
Auxiliary	Auxiliar	Extra
Axle	Eje	Axel
Axle Beam	Viga del eje	
Axle Bolt	Perno del eje	Axelbult
Axle Breather	Respiradero del eje	
Axle Carrier & Tube	Tubo y soporte del eje	
Axle Front	Frontal del eje	Framaxel
Axle Rear	Trasera del eje	Bakaxel
Axle Washer	Arandela del eje	Axelbricka
B		
Back Plate	Contraplato	Bakstycke
Bag	Bolsa	Säck
Ball	Bola	Kula
Ball End	Lado esférico	
Ball Joint	Rótula	
Ball Valve	Válvula de bola	Kulventil
Bar	Barra	Ramp
Basin	Vasija	Skål
Battery	Batería	Batteri
Battery Housing	Alojamiento de la batería	Batterikåpa
Battery Terminals	Bornes de la batería	Batteriterminal
Battery Lead	Cable de la batería	Batteribly
Battery Tray	Bandeja de la batería	Batteri platta
Beacon	Faro	Varningsljus
Beacon Bar	Barra del faro	Takramp varningsljus
Beam	Haz	Strålkastare
Bearing	Cojinete	Lager
Bell Housing	Carcasa del embrague	Svänghjulskåpa
Bellows	Fuelle	Bälg
Belt	Correa	Remm
Black	Negro	Svart
Blanking	Borrado	Stängning
Bleeper	Emisor de tonos	Backvanare
Blind Rivet	Remache ciego	Popnit
Block	Bloque	Stänga/sätta igen
Blue	Azul	Blå
Board	Tablero	Skiva
Body	Cuerpo	Kropp
Bolt	Perno	Bult

English	Español	Svenska
hex hd (hexagonal head)	cab. hexag. (cabeza hexagonal)	Bult (sexkanthuvud)
skt hd (socket head)	cab. hueca (cabeza hueca)	Bult försänkt huvud
csk hd (counter-sunk head)	cab. avell. (cabeza avellanada)	
Boom	Brazo	Bom
Boost	Empujar	Högeffekt
Bore	Calibre	Borra
Boss	Refuerzo	Knopp
Bottom	Inferior	Nertill
Bottle	Botella	Flaska
Box	Cuadro	Låda
Brace	Abrazadera	Band
Bracket (Brkt)	Soporte (Sop.)	Konsoll
Brake	Freno	Broms
Brass Wing Nut	Tuerca de mariposa de latón	Mässingsvingmutter
Breather	Respiradero	Luftare
Broom	Escobilla	Kvast
Brown	Marrón	Brun
Brush	Escobilla	Borste
Base	Base	Bas
Buffer	Amortiguador	Dämpare
Build	Construir	Bygga
Bulb	Bombilla	Lampa
Bulkhead	Mampara	Skott (i tank)
Bumper	Parachoques	Kofångare
Bump Stop	Tope	Underkörningskydd
Bungee Cord	Cuerda elástica	
Bush	Casquillo	Bussning
Buzzer	Zumbador	Summer
Button	Botón	Knapp
C		
Cab	Cabina	Hytt
Cable	Cable	Wire
Caliper	Calibrador	
Cam Shaft	Árbol de levas	Kamaxel
Camera	Cámara	Kamera
Canopy	Cúpula	Kanape
Cap	Tapa	Kåpa
Capping	Cubierta	
Carabiner	Mosquetón	Karbidhake
Carrier	Soporte	Bärare
Case	Caja	Fall

English	Español	Svenska
Casing	Carcasa	Hölje
Catalogue	Catálogo	Katalog
Catch	Fiador	Fånga
Caution	Precaución	Varning
Centre	Centro	Mitten
Chain	Cadena	Kedja
Chassis	Chasis	Chassie
Check	Control	Kontrollera
Check Valve	Válvula de retención	Kontrollventil
Chute	Conducto	Dränering
Circlip	Resorte circular	Buntband
Circuit	Circuito	Strömkrets
Clamp	Grapa	Klämma
Cleaner	Limpiador	Rengörare
Clevis	Horquilla	
Clip	Pinza	Klämma
Clutch	Embrague	Koppling
Coach	Carrocería	Kaross
Coil	Bobina	Spole
Collar	Casquillo	Krage
Complete	Completo	Slutföra
Components	Componentes	Komponent
Compressor	Compresor	Kompressor
Cone	Cono	Konisk
Connector	Conector	Kontaktor
Connecting	Conexión en curso	Ansluta
Connection	Conexión	Anslutning
Con Rod (Connecting Rod)	Biela (Biela)	
Continued (Cont.)	Continuación (Cont.)	Fortsatt
Control (Cntrl)	Control (Cont.)	Kontroll
Controller	Controlador	Kontrollant
Conventional	Convencional	Vanlig
Conversion (Conv)	Conversión (Conv.)	Omställning
Cooler	Refrigerador	Kylare
Cooling	Refrigeración	Kylning
Copper	Cobre	Koppar
Core	Núcleo	Stomme
Cotter	Chaveta	Sprint/kil
Coupling	Acoplamiento	Koppling
Cover	Cubierta	Skydd
Cowling	Capó	
Crank-case	Cárter	Vevhus

English	Español	Svenska
Cranked	Acodado	Krökt
Cross Member	Travesaño	Tvärstag
Crown Wheel	Corona dentada	Kronhjul
Curb	Borde	Kansten
Cylinder	Cilindro	Cylinder
D		
Damper	Amortiguador	Dämpare
Deflector	Deflector	Riktare
Description	Descripción	Beskrivning
Details	Detalles	Detaljer
Detergent	Detergente	Rengöring
Diagram	Diagrama	Diagram
Dial	Cuadrante	Ring
Diaphragm	Diafragma	Diafragma
Diode	Diodo	Diod
Dipped Beam	Luz de cruce	Halvljus
Dipstick	Varilla de nivel de aceite	Olje/mätsticka
Dipstick guide	Guía de la varilla de nivel de aceite	Markering oljesticka
Dipstick tube	Tubo de la varilla de nivel de aceite	Rör oljesticka
Directional	Direccional	Riktningvisare
Dirt	Suciedad	Smutts
Disc/Disk	Disco	Lamell
Display	Pantalla	Skärm
Distributor	Distribuidor	Distributör
Diverter	Desviador de flujo	Omvändare
Door	Puerta	Dörr
Double	Doble	Dubbel
Dowel	Espiga	Plugg/tapp
Down	Abajo	Ner
Dowty Seal	Junta "Dowty"	
Drag Link Tube	Biela de arrastre	
Drain Plug	Tapón de drenaje	Dräneringsplug
Drive	Transmisión	Köra
Drive Core	Núcleo de la transmisión	Drivaxel
Drive Coupling	Acoplamiento de la transmisión	Drivkoppling
Drive Dog	Retén de la transmisión	
Drive Flange	Brida de la transmisión	Drivfläns
Drive Motor	Motor de la transmisión	Drivmotor
Drive Pump	Bomba de la transmisión	Drivpump
Drive Shaft	Eje de la transmisión	Drivaxel

English	Español	Svenska
Drive Tube	Tubo de la transmisión	
Dual Sweep	Doble barrido	Dubbelsug
Dump Valve	Válvula de descarga	Övertrycksventil
Dust	Polvo	Damm
E		
Earth, electrical (Ground)	Tierra	Jord
Eccentric	Excéntrico	Eccentrix
Elbow	Codo	Vinkel
Electric	Eléctrico	Elektrisk
Electrical	Eléctrico	Elektriska
Element	Elemento	Beståndsdel
Enclosure	Caja	Omgivet
End	Extremo	Slut
End Plate	Placa de tope	Skyddsplatta
End Cap	Tapa de extremo	Skyddskåpa
Engine	Motor	Motor
Exchange	Intercambio	Växla
Exhaust	Escape	Avgaser
Exhaust Gas Recirculation (EGR)	Recirculación de los gases de escape (EGR)	Avgasventil (EGR)
Expansion	Expansión	Expantion
Extended	Extendido	Förlängd
Extension	Extensión	Förlängning
Extinguisher	Extintor	Förlängare
F		
Fan	Ventilador	Fläkt
Fastener	Sujeción	Fäste
Feed	Alimentación	Försörjning
Female	Hembra	Kvinna
Filler	Embudo	Filler
Filter	Filtro	Filter
Finisher	Unidad de acabado	Avslutare
Fire	Fuego	Eld
First	Primero	Första
Fishtail	Cola de pez	fiskstjärt
Fit	Acoplar	Passa
Fitting	Conector	Montering/installation
Fixing	Fijación	Laga
Flange	Brida	Fläns
Flap	Aleta	Dörr / öppning

English	Español	Svenska
Flash	Centelleo	Blixt
Flexible (Flexi)	Flexible (Flex.)	Flexibel
Floor	Piso	Golv
Floorplate	Placa de piso	Golvplatta
Flow	Flujo	Flöde
Fluid	Líquido	Vätska
Flywheel	Volante	Stödhjul
Foam	Espuma	Skumm
Fog	Niebla	Dimma
Foot	Pie	Fot
Forward	Directa	Framåt
Frame	Bastidor	Ram
Front	Delantero	Fram
Fuel	Combustible	Drivmedel
Function	Función	Funktion
Fuse	Fusible	Säkring
G		
Gain	Ganancia	Vinna
Galvanised	Galvanizado	Galvaniserad
Gantry	Pórtico	Brygga/ställning
Gas	Gas	Gas
Gas Strut	Montante de gas	
Gasket	Junta	Packning
Gauge	Indicador	Tryckmätare
Gauze	Tela metálica	Flor(gasbinda)
Gear	Engranaje	Växel
Geared	Accionado por engranaje	Växlad
Gearbox	Caja de cambios	Växellåda
General	General	I allmänhet
Glass	Vidrio	Glas
Glow Plug	Bujía incandescente	Glödstift
Gobbler (Nozzle Tilt)	"Gobbler"	Tilt (sugbox)
Grab	Gancho	Fånga
Grease	Grasa	Smörja
Greaser	Engrasador	Fett
Green	Verde	Grön
Grey	Gris	Grå
Grill	Rejilla	Grill
Grip	Mango	Grepp
Grub Screw	Tornillo de presión	Avdragare
Grommet	Arandela	genomföring
Guard	Protección	Skydd

English	Español	Svenska
Guide	Guía	Guide
H		
Handbrake	Freno de mano	Handbroms
Hand	Manual, a mano	Hand
Hand Primer	Bomba de mano	Handcreme
Hand Wash	Lavado a mano	Handtvätt
Handle	Asa	Handtag/vred
Hanger	Soporte colgante	Hängare
Harness	Mazo de cables	Sele
Head	Cabeza	Huvud
Headlamp	Faro	Strålkastare
Heat	Calor	Värme
Heatshield	Pantalla térmica	Värmeplåt
Heater	Calentador	Värmare
High Pressure	Alta presión	Högtryck
Hi Tip	Punta alta	Högtippande
Hinge	Bisagra	Gångjärn
Hinged	Articulado	Gångjärns hängd
Holder	Portaherramientas	Hållare
Hooks	Ganchos	Krokar
Hopper	Tolva	Behållare
Horn	Claxon	Signalhorn
Hose	Tubo flexible	Slang
Hose Tail	Extremo de tubo flexible	Slangände
Hot	Caliente	Varm
Hour Meter	Cronómetro	Timräknare
Housing	Carcasa	Kåpa/skydd
Hub	Cubo	Centrum
Hydraulic	Hidráulico	Hydraulisk
Hydrant	Boca de riego	Brandpost
Hydrant Filler		Brandpost huvud
Hydrant Hose	Tubo flexible de la boca de riego	Brandpostslang
Hydrostatic	Hidrostático	Hydrostatisk
I		
Identification	Identificación	Identifiering
Idle	Ralentí	Idealisk
Ignition (Ign)	Encendido (Enc.)	Tändning
Illuminated	Encendido	Eliminerad
Illustrated	Ilustrado	Illustrerad
Illustration	Ilustración	Illustration

English	Español	Svenska
Impeller	Propulsor	Impeller
Inclusive	Inclusivo	Inklusive
Information (Info)	Información (Info.)	Information
In	Dentro, entrada	In
Inlet	Admisión	Insläpp
Inlet Cone	Núcleo de admisión	Insläppskona
Inlet Pipe	Tubo de admisión	Insläppsrör
Injection Pump	Bomba de inyección	Injektionspump
Injector	Inyector	Injektor
Injector Pipe	Tubo del inyector	Injektorrör
Input	Entrada	Ingående
Inseal Strip	Banda de estanqueidad	
Insert	Insertar	Lägga till
Insertion	Inserción	Insättande/tillägg
Installation	Instalación	Installation
Instrument	Instrumento	Instrument
Insulator	Aislante	Isolerare
Inter Cooler	Refrigerador intermedio	Laddluftkylare
Interior	Interior	Inredning
Interim	Intermedio	Interim
Internal	Interno	Invändig
Item	Elemento	Punkt/artikel
J		
Jet	Chorro, inyector	Jet
Joint	Articulación	Punkt
Joystick	Palanca de control	Joystick
Jubilee Clip	Pinza "Jubilee"	Slangklämman
Junction	Unión	Korsning
K		
Key	Tecla	Nyckel
Key Switch	Interruptor de llave, llave de contacto	Tändningslås
Kerb	Borde	Kantsten
King Pin	Pivote central	
King Post	Palo macho	
Kit	Juego	Satts
Knob	Mando	Knopp
L		

English	Español	Svenska
label	Etiqueta	Etikett
Lamp	Lámpara	Lampa
Work Lamp	Lámpara de trabajo	Arbetsljus
Head Lamp	Lámpara de cabeza	Strålkastare
Side Lamp	Lámpara lateral	Positionsljus
Lance	Lanza	Munstycke
Lap Joint	Articulación de solape	Fogpunkt
Large	Grande	Stor
Latch	Pestillo	Regla/stänga
Lead	Plomo, avance	Bly
L.E.D. (Light Emitting Diode)	LED (diodo emisor de luz)	L.E.D diod
Leash	Correa	Remm
Left	Izquierda	Vänster
Left Hand Drive (LHD)	Conducción por la izquierda (LHD)	Vänsterstyrning
Leg	Pata	Ben
Length	Longitud	Längd
Lens	Lentes	Glas
Level	Nivel	Nivå
Lever	Palanca	Spak/hävstång
Lid	Tapa	Lock
Lift	Levantar	Lyfta
Lifting	Levantamiento	Lyfter
Light	Luz	Ljus
Side Light	Luz lateral	Sidoljus
Head Light	Faro	Strålkastare
Rear Light	Luz trasera	Bakljus
Brake Light	Luz de freno	Bromsljus
Interior Light	Luz interior	Innebelysning
Fog Light	Luz antiniebla	Dimmljus
Linch Pin	Pasador con anilla abatible	
Lining	Revestimiento interior	Bromsbelägg/beklädnad
Link	Articulación	Länk
Linkage	Varillaje de mando	Länksystem
Litre	Litro	Liter
List	Lista	List
Load	Carga, cargar	Lasta
Located	Situado	Placerad
Lock	Cierre, bloqueo	Lås
Locknut	Contratuerca	Läsmutter
Locker	Taquilla	Skåp
Locking	Cierre	Låsa
Long	Largo	Lång

English	Español	Svenska
Loom	Cableado eléctrico	Hölje
Loop	Bucle	Förbinda
Low Pressure	Baja presión	Lågtryck
Lower	Inferior, bajar	Sänka
Lubricant	Lubricante	Smörjmedel
Lubrication	Lubricación	Smörjning
M		
Machine	Máquina	Maskin
Magnet	Imán	Magnet
Magnetic	Magnético	Magnetisk
Main	Principal	Huvud
Male	Macho	Man
Management	Gestión	Skötsel
Manifold	Distribuidor	Fördelare
Manual	Manual	Manual
Manufactured	Fabricado	Tillverkad
Marker Lamp	Luz de señalización	
Master	Principal	Huvud
Master Cylinder	Cilindro maestro	Huvudcylinder
Maximum (Max)	Máximo (Máx.)	Maximum
Mesh	Malla	Galler
Metal	Metal	Metall
Meter	Metro	Meter
Micro Switch	Microinterruptor	Mikrobrytare
Minimum (Min)	Mínimo (Mín.)	Minimum
Mirror	Espejo	Spegel
Miscellaneous	Varios	Ungefärlig
Modified	Modificado	Modifierad
Module	Módulo	Modul
Monitor	Monitor, controlar	Skärm
Motor	Motor	Motor
Mount	Montura	Montera
Mounted	Montado	Monterad
Mounting	Instalación, soporte	Montera
Mud Flaps	Aleta guardabarros	Stänkskydd
Mud Guard	Guardabarros	Stänkskärm
Muffler	Silenciador	Ljuddämpare
Multi Function	Multifunción, multiuso	Flerfunktion
N		
N/A (Not Applicable)		

English	Español	Svenska
Narrow	Estrecho	Nära
Near side	Lado izquierdo	Nära sidan
Negative	Negativo	Negativ
Neutral	Neutral, punto muerto	Neutral
New	Nuevo	Ny
Nipple	Manguito	Nippel
No. (Number)	Número	Nummer
Non Return	Sin retorno	Ingen återvändo
Normal	Normal	Normal
Note	Nota	Not
Nozzle	Boquilla	Munstycke
Number	Número	Nummer
Numerical	Numérico	Numrerad
Nut	Tuerca	Mutter
Nyloc Nut	Tuerca "Nyloc"	Nylocmutter
Hex Nut	Tuerca hexagonal	Mutter sexkant
Plain Nut	Tuerca lisa	Plan mutter
Self Locking Nut	Tuerca autoblocante	Låsmutter
Thin Nut	Tuerca fina	Mutter (tunn)
Nylon Tube	Tubo de nilón	Nylonslang
O		
Obsolete	Obsoleto	Föråldrad
Off	Apagado	Av
Off Side	Lado derecho	Vid sidan av
Oil	Aceite	Olja
Olive	Oliva	Oliv
On	Encendido	På
Open	Abrir	Öppen
Opened	Abierto	Öppnad
Opening	Apertura, abertura	Öppning
Operating	Funcionamiento	Köra
Option	Opción	Tillbehör
Optional	Opcional	Valfri/frivillig
Orange	Naranja	Orange
Original	Original	Orginal
O Ring	Junta tórica	O ring
Out (Extended)	Fuera	
Outer	Exterior	Yttre
Outlet	Salida	Överskott
Output	Producción	Utkommande
Overhead	En cabeza	Över huvudet

English	Español	Svenska
Overload	Sobrecarga	Överlasta
P		
Packer	Tapón estanco	Packare
Panel	Panel	Panel
Part	Pieza	Del
Pedal	Pedal	Pedal
Pick-up (sensor)	Elegir	Sensor
Pilot (pressure)	Piloto	Pilot (tryck)
Pin	Pasador	Pinne
Pinion	Piñón	Pinjong
Pink	Rosa	Rosa
Pipe	Tubo (rígido)	Rör
Piping	Tubería	Rördragning
Piston	Pistón	Kolv
Pivot	Pivote	Styrtapp
Plastic	Plástico	Plast
Plate	Disco, placa	Tallrik
Plinth	Base	Plint
Plug	Enchufe, tapón	Plugg
Point	Punto	Punkt
Poppet Valve	Válvula de resorte	
Ports	Puertos	Port/öppning
Position	Posición	Position
Positioned	Colocado	Placerad
Post	Poste, borna	Stolpe/stötta
Potentiometer	Potenciómetro	Potensiometer
Power	Potencia	Ström
Pneumatic (See Also Air)	Neumático (véase también Aire)	Pneumatisk
Pressure	Presión	Tryck
Primer	Cebador	Primer
Production	Producción	Produktion
Prop	Apoyo	Stöd/palla under
Propshaft	Árbol de transmisión	Kardanaxel
Pull	Tirar, tracción	Drag
Pulley	Polea	Remskiva
Pulsation	Pulsación	Pulserande
Pulse	Pulso	Puls
Pump	Bomba	Pump
Purple	Púrpura	Lila
Push	Empujar, empuje	Tryck

English	Español	Svenska
Q		
Quick Release	Suelta rápida	Snabbkoppling
R		
Radiator (Rad)	Radiador (Rad.)	Kylare
Raise	Levantar	Lyfta
Raised	Levantado	Lyft
Ram	Pistón	Kolv
Ratio	Relación	Radie
Rear	Trasero	Bak
Red	Rojo	Röd
Reducer	Reductor	Reducerare
Reducing	Reducción, reduciendo	Reducera
Reduction	Reducción	Reducering
Reel	Carrete	Hjul
Refer	Ver	Referera
Refill	Rellenar	Återfylla
Regulator	Regulador	Regulator
Related	Relacionado	Besläktad
Relay	Relé	Relä
Release	Liberación	Lösgöra
Relief Valve	Válvula de descarga	Övertrycksventil
Remote	Remoto	Mottagare
Repair	Reparar	Reparera
Replacement	Sustitución	Ersätta
Resister	Registrar, registro	Motstånd
Restrictor	Estrangulador	Strypning
Retainer	Fiador	Förskottshyra
Retaining	Retención	
Return	Retorno	Återvända
Reverse	Inverso	Backa
Reversing	Inversión	Backa
Right	Derecha	Höger
Right Hand Drive (RHD)	Conducción por la derecha (RHD)	Högerstyrd
Rim	Llanta	Kant/fals
Ring	Anillo	Ring
Road	Carretera	Väg
Rod	Varilla	Rulle
Rolling	Rodamiento	Rullande
Rotary	Giratorio, rotativo	Roterande

English	Español	Svenska
Rotate	Girar	Rotera
Rotating	Giratorio, rotativo	Rotera
Rotation	Giro	Rotation
Rubber	Goma	Gummi
S		
Safety	Seguridad	Säkerhet
Scraper	Escariador	Skrapa
Screen	Filtro, pantalla	Galler
Screw	Tornillo	Skruv
csk hd (counter-sunk head)	Cab. avell. (cabeza avellanada)	
Hex hd (hexagonal head)	Cab. hexag. (cabeza hexagonal)	Skruv sexkant
skt hd (socket head)	Cab. hueca (cabeza hueca)	Skruv (fösänkt)
Seal	Junta	Tätning
Sealant	Sellante	Flytande tätningmedel
Sealing	Sellado	Täta
Seat	Asiento	Säte
Securing	Fijación	Säkra
Selector Shaft	Eje selector	Väljaraxel
Self Tapping	Aterrajado automático	Självdränkande
Sender	Conmutador selector	Sändare
Sensor	Sensor	Sensor
Separation	Separación	Separerat
Serial	Serie	Serie
Service Exchange (S/EX)	Intercambio de servicio	Utbytesdel
Setscrew	Tornillo de fijación	Sättskruv
Shaft	Eje	Skaft
Shells	Cuerpos	Snäckor
Shield	Protector	Skjöld
Shim	Suplemento	Shims
Shock Absorber	Amortiguador	Stötdämpare
Shoe	Zapata	Sko
Short	Corto	Kort
Shovel	Pala	Skyffel
Side Access Door	Puerta de acceso lateral	Sidodörr
Sight	Vista	Sikt
Silencer	Silenciador	Ljuddämpare
Silicon	Silicona	Silikon
Single	Único, sencillo	Enkel
Skirt	Faldón	Kjol
Slate	Pizarra	

English	Español	Svenska
Sleeve	Manguito	Muff
Slew	Pivotar	Svänga/slira
Slewing	Pivotaje	Svängande/slirande
Sliding	Deslizamiento	Glidande
Slotted	Ranurado	Spräckt
Small	Pequeño	Liten
Socket	Casquillo	Socket
Solenoid	Solenoid	Solenoid
Spacer	Separador	Distans
Spare	Repuesto	Reserv
Speakers	Altavoces	Högtalare
Special	Especial	Special
Speed	Velocidad	Fart
Spherical	Esférico	Klotformig
Spigot	Espiga	Rör
Spindle	Husillo	Spindel
Splined	Acanalado	Flisad/splittrad
Splinter	Partícula	Skärva/splitter
Split Pin	Chaveta hendida	Låspinne
Splitter	Separador	Fördelare
Spray	Pulverizador, rociador	Spaya
Spring	Muelle	Fjäder
Stabiliser	Estabilizador	Stabiliserare
Stabilising	Estabilización	Stabilisera
Stack	Pila	Fullpropad med
Standard	Estándar	Standard
Standpipe	Tubo vertical	Vattenpost
Starter	Motor de arranque	Startmotor
Steel	Acero	Stål
Steering	Dirección	Styrning
Stem	Vástago	Stoppa
Stiffener	Contrafuerte, larguero	Förtjockare
Stop	Parar	Stopp
Storage	Almacenamiento	Lagra
Stowage	Estiba	Stuvningsutrymme
Straight	Recto	Rakt
Strap	Tira de sujeción	Sätta fast
Strip	Banda	Ta bort
Strut	Puntal	Balk/stötta
Stub	Tope	Stump/talong
Stud	Espárrago	
Studded	Con pasador	

English	Español	Svenska
Studding	Pasante	
Sub Frame	Bastidor auxiliar	Underram
Suction Box	Caja de succión	
Suction Fan	Ventilador de succión	Sugfläkt(turbin)
Suction Nozzle	Boquilla de succión	Sugmunstycke
Sump	Sumidero	Oljetråg
Supply	Suministro	Förse
Support	Asistencia, soporte	Stödja
Suppression	Supresión	Undertryck
Suspension	Suspensión	Fjädring
Sweep	Barrido	Sopa
Sweeping	Barrido, barriendo	Sopa
Swing	Oscilación	Svänga
Switch	Interruptor	Brytare
Switches	Interruptores	Brytare
Swivel	Giratorio	Svängbar
System	Sistema	System
T		
Tab Washer	Arandela con lengüeta	
Tachograph	Tacógrafo	Färdskrivare
Tachometer	Tacómetro	Hastighetsmätare
Tandem	Tándem	Tandem
Tank	Tanque	Tank
Tapered	Cónico	Avsmalnande
Taper Lock	Cierre cónico	Plugg
Tee Key	Llave en T	Gren
Temperature (Temp)	Temperatura (Temp.)	Temperatur
Template	Plantilla	Mall
Tensioner	Tensor	Sträckare
Terminal	Terminal	Terminal
Test	Prueba	Test
Thermostat	Termostato	Termostat
Thick	Espeso	Tjock
Thimble	Dedal	Fingerborg
Thin	Delgado	Smal
Throttle	Regulador de gases	Trottel
Thrust	Empuje	Tryck
Tie Rod	Barra de acoplamiento transversal de la dirección	
Tilt	Inclinar	Tilt
Tilting	Inclinación	Tilta

English	Español	Svenska
Timer	Temporizador	Timer
Timing	Sincronización	Tids anpassa
Toggle	Báscula	Vippa
Tool	Herramienta	Verktyg
Toolbox	Caja de herramientas	Verktygslåda
Toothed	Dentado	Signalhorn
Top	Superior	Topp
Tow	Remolque	Dra / bogsera
Tow Ball	Bola de remolque	Dragkula
Tow Bar	Barra de remolque	Dragkrok
Tow Point	Punto de remolque	Dragpunkt
Track Rod	Tirante transversal	
Trailer	Remolque	Släp
Transfer Gearbox	Caja de cambios transferencia, caja transfer	Tillsattsväxellåda
Transmission	Transmisión	Transmission
Travel	Recorrido, viaje	Resa
Trunking	Unión	
Trunnion	Muñón	
Tube	Tubo	Rör
Tubing	Sistema de tuberías	Rördragning
Turbocharger (Turbo)	Turbocompresor (Turbo)	Turbo
Twin	Gemelo, bimotor	Dubbel
Type	Tipo	Typ
Typical	Típico	Typisk
Tyre	Neumático	Däck
U		
Uncompressed	No comprimido	Okomprimerad
Underside	Inferior	Undersida
Universal Joint (U/J)	Junta cardánica (U/J)	Knutkors
Union	Unión	Förena
Unit	Unidad	Del
Un-Loader	Descargador	Avlastning
Up	Arriba	Upp
Update	Actualizar	Uppdatera
Usage	Uso	Andvändning
V		
Valve	Válvula	Ventil
Variant	Variante	Variant
Vehicle	Vehículo	Fordon

English	Español	Svenska
Voltage	Tensión	Volt
W		
Wander Hose	tubo flexible móvil	Sugslang (lövsug)
Warning	Advertencia	Varning
Washer	Arandela	Bricka
Water	Agua	Vatten
Wear	Desgaste	Slitage
Weed Ripper	Escardador	Ogräs
Welded	Soldado	Svetsad
Wheel	Rueda	Hjul
White	Blanco	Vit
Wide Sweep	Barrido amplio	Vals
Windscreen	Parabrisas	Vindruta
Wiper	Limpiaparabrisas	Torkare
Wires	Cables	Ledningar
Wiring	Cableado	Ledningsdragning
Black, Blue, Brown, Green, Grey, Orange, Pink, Purple, Red, White Yellow	Negro, Azul, Marrón, Verde, Gris, Naranja, Rosa, Púrpura, Rojo, Blanco Amarillo	Svart Blå Brun Grön Grå Orange Rosa Lila Röd Vit Gul
Work Light	Lámpara de trabajo	Arbetsljus
X		
Xenon	Xenón	Xenon
Y		
Yellow	Amarillo	Gul
Yoke	Horquilla	Sammankoppla

Scarab Sweepers Limited
Pattenden Lane - Marden - Kent TN12 9QD, UK
T: +44 (0)1622 831 006
E: scarab@scarab.fayat.com - W: scarab-sweepers.com
Registered in England No. 18923459 - VAT No. GB 374 5002 68
Registered Office: Pattenden Lane, Marden, Tonbridge, Kent TN12 9QD, UK