



# **SCARAB** *Hydrostatic* **Truck-Mounted Sweepers**



## **OPERATOR'S MANUAL** ***With CANbus<sup>2</sup>***

 This document contains important Health & Safety advice and must remain with the vehicle at all times

M/c Serial No:

# MAIN FEATURES OF A TYPICAL SCARAB SWEEPER

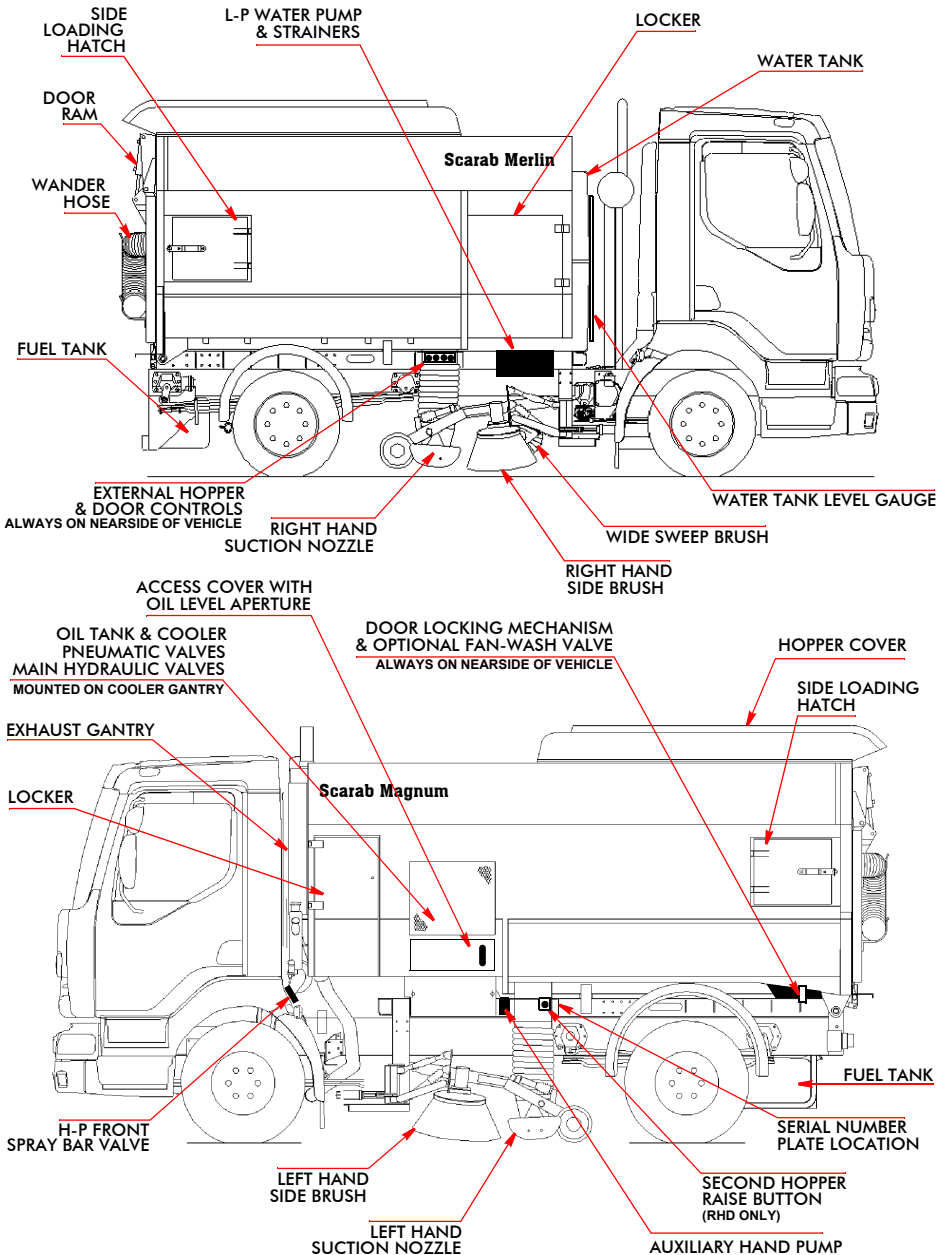



# OPERATOR'S MANUAL

## **HYDROSTATIC TRUCK-MOUNTED SWEEPERS**

### **VEHICLES EQUIPPED WITH CANbus 2 CONTROLS**

When re-ordering this document, please quote the following Part Number:

#### **Manual Z032193**

Original Issue .....April 2007

Amdt. 1 .....Jan. 2010

This manual is published by the Technical Publications Department of Scarab Sweepers Ltd. and every effort is made to ensure that the information it contains is correct at the time of publication. Due to a policy of continuous development, however, the Company reserves the right to alter the specification and to supply when so altered without reference to illustrations and descriptions in this manual.

## **Scarab Sweepers Limited**

**Pattenden Lane, Marden, Kent TN12 9QD**

Telephone: 01622 831006

Fax: 01622 832417

International: +44 1622 831006

International +44 1622 832417

e-mail: [scarab@scarab.sales.com](mailto:scarab@scarab.sales.com)

Web site: [www.scarab-sweepers.com](http://www.scarab-sweepers.com)

# SCARAB HYDROSTATIC TRUCK-MOUNTED SWEEPERS

## GENERAL INFORMATION



### **WARNING - VOLTAGE SENSITIVE COMPONENTS**

**DO NOT USE A BOOST STARTER / SUPER START. IF BATTERIES ARE NOT CHARGED ALWAYS USE A FRESH SET. A BOOSTED START WILL BURN OUT THE VEHICLES ELECTRONIC CONTROL NODES.**

### **WEIGHTS, DIMENSIONS AND CAPACITIES**

#### **Gross Vehicle Weight (GVW)**

MERLIN	7.5 tonne to 12.0 tonne
MAGNUM	13.0 tonne to 15.0 tonne

#### **Payload\***

MERLIN	Typically 2300 kg to 6300 kg
MAGNUM	Typically 6340 kg to 8540 kg

Overall Length\* ..... Typically 5500 mm

Front Overhang\* ..... Typically 1240 mm

Rear Overhang\* ..... Typically 1350 mm

Wheelbase\* ..... Typically 3000 mm

Overall Width\* ..... Typically 2220 mm

Overall Height (hopper lowered)\* ..... Typically 2980 mm

Overall Height (hopper raised)\* ..... Typically 4180 mm

#### **Hopper Capacity**

MERLIN ..... 5.5 m<sup>3</sup>

MAGNUM ..... 7.5 m<sup>3</sup>

#### **Fuel Tank Capacity\***

MERLIN ..... Typically 100 litres

MAGNUM ..... Typically 150 litres

Hydraulic Tank ..... 15 litres

Water Tank\* ..... 900 litres to 1800 litres

*\* Dependent upon chassis and specification*

### **NOTE:**

In view of the fact that many of the foregoing values are subject to variables such as chassis type and machine specification, it is not possible to quote precise details. If this type of information is required, Scarab recommend that you contact our Technical Sales staff giving your sweeper's Serial Number.

### **TOWING**

SERIOUS DAMAGE TO THE TRANSMISSION WILL RESULT IF THE VEHICLE IS TOWED WHILE THE HYDROSTATIC DRIVE IS ENGAGED.

If towing is necessary, it is imperative that the hydrostatic drive is disengaged before making any attempt to tow the vehicle.

### **IDENTIFICATION PLATES**

The SERIAL NUMBER PLATE is located on the rear face of the left hand suction nozzle spigot. The Serial Number will comprise four numerical digits only (for example 5843).

For the location of the vehicle's VIN PLATE and CHASSIS NUMBER, refer to the chassis manufacturers' documentation.

### **LIMITATIONS OF USE**

The Scarab Merlin and Magnum are classified as truck-mounted heavy-duty suction road sweepers and, as such, are intended only for operation in the sweeping and associated roles for which they have been expressly designed.

### **APPLICABILITY**

This manual covers the operating requirements of the Scarab **Merlin** and **Magnum Hydrostatic** sweepers with the CANbus 2 system. For operating information on the Unidrive range of CANbus sweepers, please refer to Manual No. Z032194. For non CANbus versions please refer to publications Z027055 (Hydrostatic) and Z027054 (Unidrive).

# SCARAB HYDROSTATIC TRUCK-MOUNTED SWEEPERS

## TABLE OF CONTENTS

<i>Para Title</i>	<i>Page</i>
<b>GENERAL INFORMATION</b> .....	<b>1</b>
<b>TABLE OF CONTENTS (THIS PAGE)</b> .....	<b>2</b>
<b>HEALTH AND SAFETY ADVICE</b> .....	<b>3</b>
<b>EXPLANATION OF SWITCH OPERATING SYMBOLS</b> .....	<b>4</b>
<b>OPERATING ADVICE</b> .....	<b>6</b>
<b>THE CANbus SYSTEM</b> .....	<b>7</b>
<b>DESCRIPTION OF MAIN CONTROL PANEL</b> .....	<b>8</b>
<b>DESCRIPTION OF AUXILIARY CONTROL PANEL</b> .....	<b>13</b>
Rear-mounted Nozzle Option .....	15
Additional Controls and Instruments .....	16
<b>OPERATING MODES</b> .....	<b>17</b>
Engaging Hydrostatic Drive .....	17
Suction Fan Boost-setting .....	18
Climbing Gradients .....	18
Selecting Normal-Drive Mode .....	19
Reducing Noise Levels and Fuel Consumption .....	19
<b>DISCHARGING THE HOPPER (TIPPING)</b> .....	<b>20</b>
Operating the Rear Door .....	20
Operating the Hopper .....	21
In-cab Controls .....	21
External Controls .....	22
Closing the Rear Door .....	22
<b>USING THE AUXILIARY HYDRAULIC PUMP</b> .....	<b>23</b>
<b>WANDER HOSE &amp; WANDER BOOMS</b> .....	<b>27</b>
<b>USING THE LOW-PRESSURE WATER PUMP</b> .....	<b>29</b>
Lubrication / Draining .....	29
<b>USING THE OPTIONAL HIGH-PRESSURE WATER PUMP</b> .....	<b>30</b>
Oil Level / Draining .....	31
<b>OPTIONAL SUCTION FAN WASH-ASSIST SYSTEM</b> .....	<b>31</b>
<b>RECOMMENDED OPERATOR'S ROUTINE MAINTENANCE</b> .....	<b>33</b>
<b>KEY MAINTENANCE PROCEDURES</b> .....	<b>35</b>
Cleaning the Suction Fan .....	35
Suction Nozzle Clearances .....	36
Side Brushes & Skirts .....	36
Draining & Cleaning the Water Strainers .....	37
Manual Greasing .....	38
Recommended Lubricants & Consumables .....	40
Fluid Levels .....	40
<b>LEGIONELLA STATEMENT</b> .....	<b>41</b>
<b>ADDITIONAL INFORMATION (if applicable to this machine)</b> .....	<b>Inside Back Cover</b>

# SCARAB HYDROSTATIC TRUCK-MOUNTED SWEEPERS

## HEALTH & SAFETY ADVICE

**THIS OPERATORS MANUAL CONTAINS ESSENTIAL INFORMATION AND MUST REMAIN WITH THE VEHICLE AT ALL TIMES.**

**IN THE INTERESTS OF YOUR HEALTH AND SAFETY, IT IS IMPORTANT THAT THE FOLLOWING POINTS ARE OBSERVED AT ALL TIMES:**

- AT NO TIME SHOULD UNQUALIFIED PERSONNEL BE PERMITTED TO OPERATE OR WORK ON THE SCARAB SWEEPER.
- BEFORE DRIVING THE VEHICLE ENSURE THAT ALL RELEVANT VEHICLE CHECKS HAVE BEEN CARRIED OUT, THAT ALL EQUIPMENT IS STOWED AND THAT THE BRUSHES HAVE BEEN RAISED.
- DO NOT OVERLOAD THE HOPPER.
- DO NOT DRIVE THE VEHICLE WITH THE HOPPER IN THE RAISED POSITION, EVEN IF THE HOPPER IS EMPTY.
- ALWAYS USE THE SAFETY PROP TO SUPPORT A RAISED HOPPER. NEVER WORK UNDER A RAISED CAB OR HOPPER UNLESS THE APPROPRIATE PROP IS IN POSITION.
- BEFORE OPERATING EITHER THE HOPPER-TIP CONTROLS OR REAR DOOR, ENSURE THAT THERE IS SUFFICIENT CLEARANCE AND THAT IT IS SAFE TO DO SO. ENSURE THAT ALL PERSONNEL ARE CLEAR OF THE REAR DOOR.
- BEFORE WORKING ON THE MACHINE:  
POSITION THE VEHICLE ON FIRM, LEVEL GROUND, APPLY THE HANDBRAKE, STOP THE ENGINE, REMOVE THE IGNITION KEY.
- BEFORE STARTING THE ENGINE ENSURE THAT ALL CONTROLS ARE SWITCHED OFF AND THAT THE VEHICLE IS IN NEUTRAL.
- KEEP LONG HAIR, LOOSE CLOTHING AND HANDS AWAY FROM MOVING PARTS.
- HIGH PRESSURE WATER CAN BE HAZARDOUS, ALWAYS WEAR SUITABLE EYE PROTECTION WHEN OPERATING THE HIGH-PRESSURE WATER PUMP AND WHEN USING THE LANCE. DO NOT DIRECT THE WATER JET AT OTHER PERSONS. BEWARE OF ELECTRICAL INSTALLATIONS ON PUBLIC BUILDINGS & LAMP POSTS Etc. AND ALWAYS EXERCISE EXTREME CAUTION IN PUBLIC PLACES.

THE HAZARD SYMBOL  IDENTIFIES GENERAL SAFETY RELATED TEXT THROUGHOUT THIS DOCUMENT. WHERE APPROPRIATE, THE FOLLOWING ADDITIONAL SAFETY SYMBOLS ARE ALSO USED:  EYE PROTECTION,  PROTECTIVE FOOTWEAR AND  GLOVES.

The **Caution Symbol**  identifies where the observation of a specific procedure is required to avoid equipment damage or under-performance.







The **Information Symbol**  identifies text offering helpful advice additional to the main instructions.

The **Check Symbol**  identifies text calling for a visual examination to confirm the condition or status of a specific item.















**REMEMBER, FAILURE TO COMPLY CAN RESULT IN SERIOUS INJURY.  
IF IN DOUBT, ASK!**

# SCARAB HYDROSTATIC TRUCK-MOUNTED SWEEPERS

## ADDITIONAL SAFETY ADVICE SYMBOLS

CHECK VEHICLE BEFORE DRIVING	IN NEUTRAL SWITCHES OFF BEFORE STARTING	CHECK ALL CLEAR TO RAISE BODY	FIRM LEVEL GROUND ONLY	USE CAB OR HOPPER SAFETY PROP	DO NOT DRIVE WITH BODY UP
					



















## SWITCH OPERATING SYMBOLS

MAIN SWEEPING PANEL SWITCHES (FROM LEFT TO RIGHT & TOP TO BOTTOM)	
<b>F1</b> <b>F2</b>	SPARE ⚠️⚠️ (Additional information is appended at back of manual when these switches are used to operate non-standard optional equipment).
	HAZARD WARNING BEACONS
	HYDROSTATIC DRIVE
	HIGH PRESSURE FRONT SPRAY BAR - RAISE / LOWER. <b>The spray bar will operate in either position.</b>
	SIDE BRUSH - ON / OFF
	SUCTION NOZZLE - RAISE / LOWER
	WIDESWEEP BRUSH - ON / OFF
	SIDE BRUSH & SUCTION NOZZLE WATER SPRAYS - ON / OFF
	SUCTION NOZZLE ADDITIONAL WATER - ON / OFF ⚠️
	WIDESWEEP WATER SPRAYS - ON / OFF
	WORK LIGHTS - ON / OFF
	SIDE BRUSH PRESSURE - UP ⚠️
	SIDE BRUSH PRESSURE - DOWN ⚠️
	WIDESWEEP PRESSURE - UP ⚠️
	WIDESWEEP PRESSURE - DOWN ⚠️

**Continued...**

# SCARAB HYDROSTATIC TRUCK-MOUNTED SWEEPERS

## SWITCH OPERATING SYMBOLS

 	SUCTION FAN - ON / BOOST
 	BRUSH SPEED ADJUSTMENT
	FRONT BRUSH - RAISE / LOWER ☼
	FRONT BRUSH - IN / OUT ☼
	FRONT BRUSH + WATER SPRAY - ON ☼
 	HOPPER BODY - RAISE / LOWER
	SAFETY INTERLOCK - HOPPER & REAR DOOR
	REAR DOOR - OPEN
<b>REAR-MOUNTED SUCTION NOZZLE OPTION</b>	
	REAR NOZZLE - RAISE / LOWER ☼
	REAR NOZZLE - TILT ☼
	REAR WORK LIGHTS - ON / OFF ☼
<b>AUXILIARY (DOOR) PANEL SWITCHES</b>	
	SIDE BRUSH IN/OUT (This feature will also be activated when using the multi-function switch to control side brush IN/OUT movement.
	CRUISE CONTROL (PEDAL POSITION ONLY) / SPARE FOR OPTION
	HIGH PRESSURE WATER PUMP ☼
	SUCTION NOZZLE TILT
	COMBINED BRUSH MASTER / MULTI-FUNCTION SWITCH - RAISES / LOWERS ACTIVE SWEEP GEAR + SIDE BRUSH IN/OUT + VARIABLE-NOZZLE-TILT
☼ THIS SYMBOL INDICATES OPTIONAL EQUIPMENT FITS.	



# SCARAB HYDROSTATIC TRUCK-MOUNTED SWEEPERS

## LCD SCREEN INFORMATION

SWEEP MODE (PANEL ON)			
UPPER ROW	SUCTION FAN SPEED		
LOWER ROW	ROAD SPEED / ANY ACTIVE WARNINGS (SEE BELOW)		
	COMMON WARNINGS (number & text) & OPERATING CONDITIONS		BUZZER
	1: LOW OIL LEVEL, STOP (Engine running / All switches disabled *)		YES
	6: LOW OIL LEVEL (Engine NOT running / All switches disabled *)		NO
	2: HIGH OIL TEMP (Panel is ON / Engine running)		YES
	3: LOW BATTERY (When battery signal less than 23 Volts)		YES
	4: LOW WATER (Panel is ON / H-P pump switch is disabled)		NO
	5: HOPPER UP		NO
8: LOAD INDICATOR (optional)		NO	
DRIVE MODE (IGN ON / PANEL OFF)			
UPPER ROW	SCARAB SWEEPERS		
LOWER ROW	ENGINE SPEED (rpm)		
* All switches EXCEPT <b>Panel ON/STANDBY</b> , <b>Work-lights</b> and <b>Beacons</b> are disabled.			

## OPERATING ADVICE

Please remember, the information provided in this handbook is designed to ensure that the Scarab sweeper operates both safely and efficiently.

A poorly maintained machine will become unreliable, inefficient and potentially dangerous. Always observe the recommended maintenance and safety related advice provided.

Many supposed operating problems can be traced to a lack of simple daily maintenance. Going out to sweep in a machine that has blocked screens, a dirt encrusted suction fan, poorly adjusted suction nozzles or brushes is not only a waste of time; it is also a waste of fuel.

Unless it is wet or raining, ALWAYS use the low-pressure water spray system when sweeping. This will not only reduce the amount of dust generated, it will also ensure more efficient collection of material. This is because wet material is heavier and will drop more readily from the air stream inside the hopper. If swept *dry* more of the finer material will pass through the screens, wearing out the fan blades on its way back to the environment behind you.

## THE CANbus SYSTEM (\* INDICATES OPTIONAL EQUIPMENT)

The CANbus system comprises two control panels (main and auxiliary) and a number of control nodes (normally seven). The system controls and monitors all sweeper functions and maintains a log of various operating parameters such as operating hours and any fault conditions that might occur. The main panel contains a microchip which holds all the program information and the data logs.

**Control nodes:** These are located adjacent to the systems they control.

**Switches:** The CANbus control panels use touch switches; these are covered by a flexible overlay to identify their functions. The various types of switch function are grouped in two ways.

Firstly they are colour coded as follows:

**ORANGE** = Electrical functions such as lighting.

**RED** = Critical functions (e.g. Hopper Raise).

**PALE GREEN** = Sweeping functions.

**BLUE** = Water Spray functions.

Secondly, switches that control functions that are available either on/or with both sides of the machine, e.g. side brushes and widesweep, are grouped with left, right and centre function controls being positioned accordingly on the panel. These are positioned within the light grey area in the centre of the control panel.

Each switch has a red LED located at its upper left hand corner. This illuminates when the switch is ON (latched) or PRESSED (non-latching).

Most switches are of the latching type (press once to turn ON and again to turn OFF) however there are a number of non-latching switches. These will only function while they are held down and are as follows:

- (a) Safety Interlock
- (b) Hopper Body RAISE
- (c) Hopper Body LOWER
- (d) Rear Door OPEN
- (e) Sweep Master - Multi-function Switch (detented to the central (Master ON) position from the side brush and nozzle-tilt positions).

The main panel also incorporates a Liquid Crystal Display (LCD) screen and a light-sensor.

The LCD provides real-time information relevant to the operating status of the machine, in the form of warnings or feed-back, and acts as the system inter-face when using the self-diagnostic facility.

The light-sensor automatically controls the switch/LCD back-lighting to ensure legibility in low light conditions.

# SCARAB HYDROSTATIC TRUCK-MOUNTED SWEEPERS

## MAIN PANEL SWITCH DESCRIPTIONS

Switch functions are described from Left to Right and Top to Bottom.

**i** Switches that are fully enabled **ONLY** when the Master Switch is **ON** or Sweep Mode is **ON** are identified by the following symbols.



LIQUID CRYSTAL DISPLAY (LCD SCREEN)

**N/A** FUNCTION IS NOT APPLICABLE IN THIS SWEEPER CONFIGURATION

AMBIENT LIGHT SENSOR

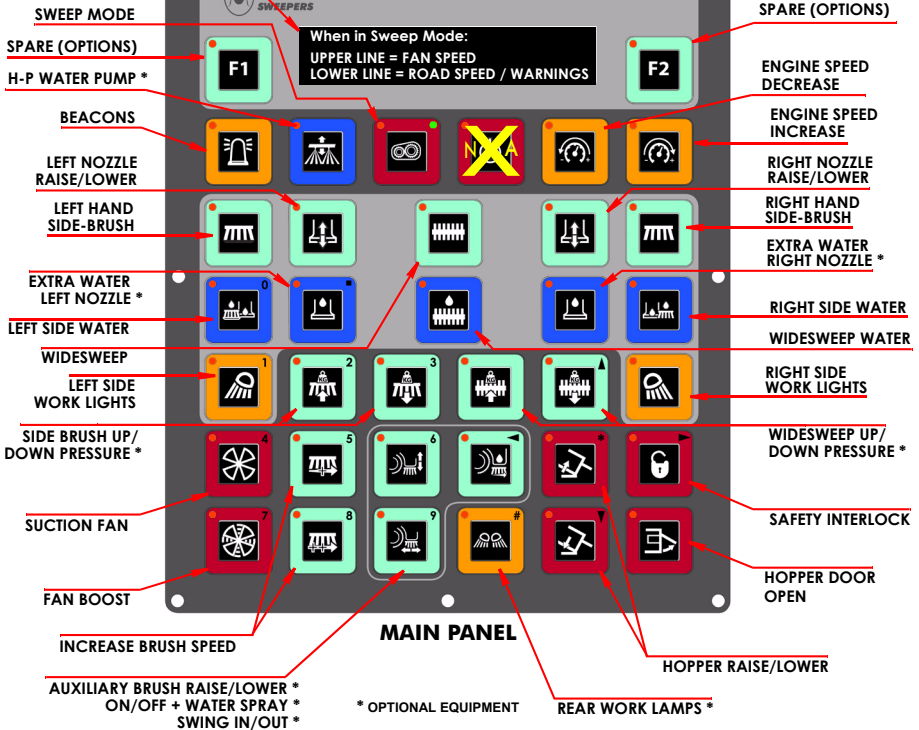

**Fig. 1 Main Control Panel Layout**

**F1 / F2 SWITCHES** - Press to activate special options when fitted.

**BEACON SWITCH** - Press to operates all hazard beacons fitted to the vehicle. Red LED illuminates when active.

**HIGH-PRESSURE SPRAY BAR RAISE LOWER SWITCH \*** - Press to lower the spray bar. The red LED will illuminate when the feature is selected. The switch is not enabled until the H-P pump is switched ON. Switching the pump OFF will cause the spray bar to be raised.



**Continued...**

# SCARAB HYDROSTATIC TRUCK-MOUNTED SWEEPERS

**HYDROSTATIC GEARBOX SWITCH** - Press to engage hydrostatic drive. The RED LED lights when in conventional drive mode and the GREEN LED indicates when the vehicle is in hydrostatic drive mode.



**ENGINE SPEED DECREASE** - Press and hold until engine speed has reduced to the required level. The red LED will illuminate while the switch is active.



**ENGINE SPEED INCREASE** - Press and hold until engine speed has increased to the required level. The red LED will illuminate while the switch is active.



**LEFT HAND SIDE-BRUSH SWITCH** - Press to start the side-brush. The red LED illuminates when the feature is selected. On single-sweep machines the non-sweeping side's switch/LED will not illuminate. See also side brush SWING IN/OUT.



**LEFT HAND SUCTION NOZZLE RAISE/LOWER SWITCH** - Press to lower the suction nozzle. The red LED illuminates when the feature is selected. On single-sweep machines the non-sweeping side's switch / LED will not illuminate.



**WIDESWEEP BRUSH SWITCH** - Press to start the widesweep brush. The brush will lower to the sweeping position and, on dual sweep machines, will swivel to the primary sweeping side unless over-ridden. The red LED illuminates when the feature is selected.



**RIGHT HAND SUCTION NOZZLE RAISE/LOWER SWITCH** - Press to lower the suction nozzle. The red LED illuminates when the feature is selected. On single-sweep machines the non-sweeping side's switch/LED will not illuminate.



**RIGHT HAND SIDE-BRUSH SWITCH** - Press to start the side-brush. The red LED illuminates when the feature is selected. On single-sweep machines the non-sweeping side's switch/LED will not illuminate. See also side brush SWING IN/OUT switch.



**LEFT HAND SIDE-BRUSH/NOZZLE WATER SWITCH** - Press to start the dust-suppression water jets for the side-brush and suction nozzle. The red LED illuminates when the feature is selected.



**LEFT HAND SUCTION NOZZLE - ADDITIONAL WATER SWITCH \*** - Press to start the additional water jets for the suction nozzle. The red LED illuminates when the feature is selected.



**WIDE SWEEP WATER SWITCH** - Press to start the dust-suppression water jets for the widesweep brush. The red LED illuminates when the feature is selected.



**RIGHT HAND SUCTION NOZZLE - ADDITIONAL WATER SWITCH \*** - Press to start the additional dust-suppression water jets for the suction nozzle. The red LED illuminates when the feature is selected.



# SCARAB HYDROSTATIC TRUCK-MOUNTED SWEEPERS

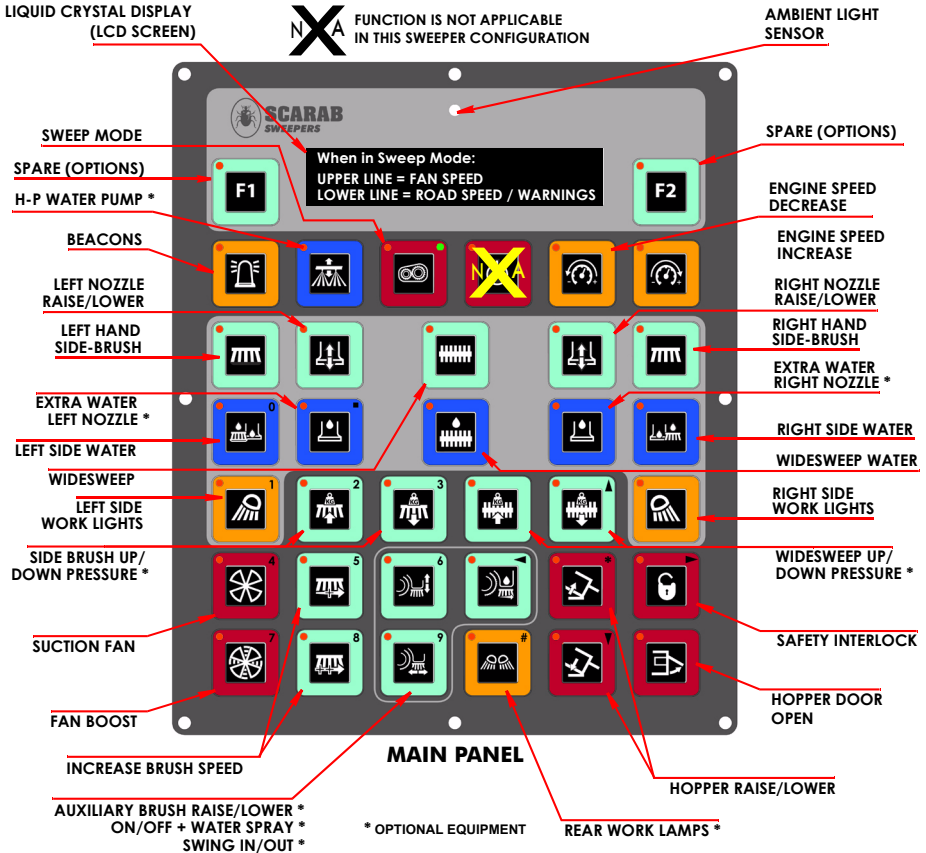

**Fig. 2 Main Control Panel Layout**

**RIGHT HAND SIDE-BRUSH/NOZZLE WATER SWITCH** - Press to start the dust-suppression water jets for the side-brush and suction nozzle. The red LED illuminates when the feature is selected.



**LEFT HAND WORK-LIGHTS** - Press to turn the work-lights ON. The red LED illuminates when the feature is selected.

**i** Please refer to Page 16 for details on pre-setting the brush air pressure-regulator for use with the following four control switches.

**SIDE-BRUSH 'UP' PRESSURE SWITCH \*** - Press to allow a controlled amount of pressure to the bottom of the brush lift ram(s) and reduce the brush's surface pressure. Use in conjunction with the air-pressure regulator. The red LED illuminates when the feature is selected. Will affect both side brushes, when both selected, on dual sweep machines.



**Continued...**

# SCARAB HYDROSTATIC TRUCK-MOUNTED SWEEPERS

**SIDE-BRUSH 'DOWN' PRESSURE SWITCH \*** - Press to allow a controlled amount of pressure to the top of the brush lift ram and increase the brush's surface pressure. Use in conjunction with the air-pressure regulator. The red LED illuminates when the feature is selected. Will affect both side brushes, when both selected, on dual sweep machines.



**WIDESWEEP 'UP' PRESSURE SWITCH \*** - Press to allow a controlled amount of pressure to the bottom of the brush lift ram(s) and reduce the brush's surface pressure. Use in conjunction with the air-pressure regulator. The red LED illuminates when the feature is selected.



**WIDESWEEP 'DOWN' PRESSURE SWITCH \*** - Press to allow a controlled amount of pressure to the top of the brush lift ram(s) and increase the brush's surface pressure. Use in conjunction with the air-pressure regulator. The red LED illuminates when the feature is selected.



**RIGHT HAND WORK-LIGHTS** - Press to turn the work-lights ON. The red LED illuminates when the feature is selected.

**SUCTION FAN SWITCH** - Press to start the fan. Red LED illuminates when the fan is ON. Fan speed (approximately 2000 rpm) is displayed on the LCD screen. This switch remains active when the fan-boost switch is pressed. (See also Fan Boost switch)



**BRUSH SPEED (+) SWITCH** - Press to increase brush speed to 125 rpm. The red LED illuminates when the feature is active. Press again to return to normal brush speed (If Brush Speed (++) is selected (See Page 12) when this feature is active Brush Speed (+) will be automatically deselected).



**FRONT BRUSH RAISE/LOWER SWITCH** - Press to lower the front brush assembly. The red LED illuminates when the feature is selected.



**FRONT BRUSH ON/OFF + WATER SPRAY SWITCH** - Press to start the front brush and simultaneously turn on the dust suppression water spray. The red LED illuminates when the feature is selected.



**HOPPER RAISE SWITCH** - Press and hold down simultaneously with the safety interlock switch to raise the hopper. the red LED illuminates as soon as the hopper starts to rise.



 For details of externally mounted hopper controls refer to Page 22.

**SAFETY INTERLOCK SWITCH** - Press and hold while operating the in-cab hopper or rear door switches. The red LED illuminates when the switch is activated.



**SUCTION FAN 'BOOST' SWITCH** - Press to activate the fan boost mode. This increases fan speed to approx. 2200 rpm. The red LED illuminates while the feature is selected and the fan speed indicated on the LCD will change to show approximately 2200 rpm. Press again to revert to normal fan speed.



# SCARAB HYDROSTATIC TRUCK-MOUNTED SWEEPERS

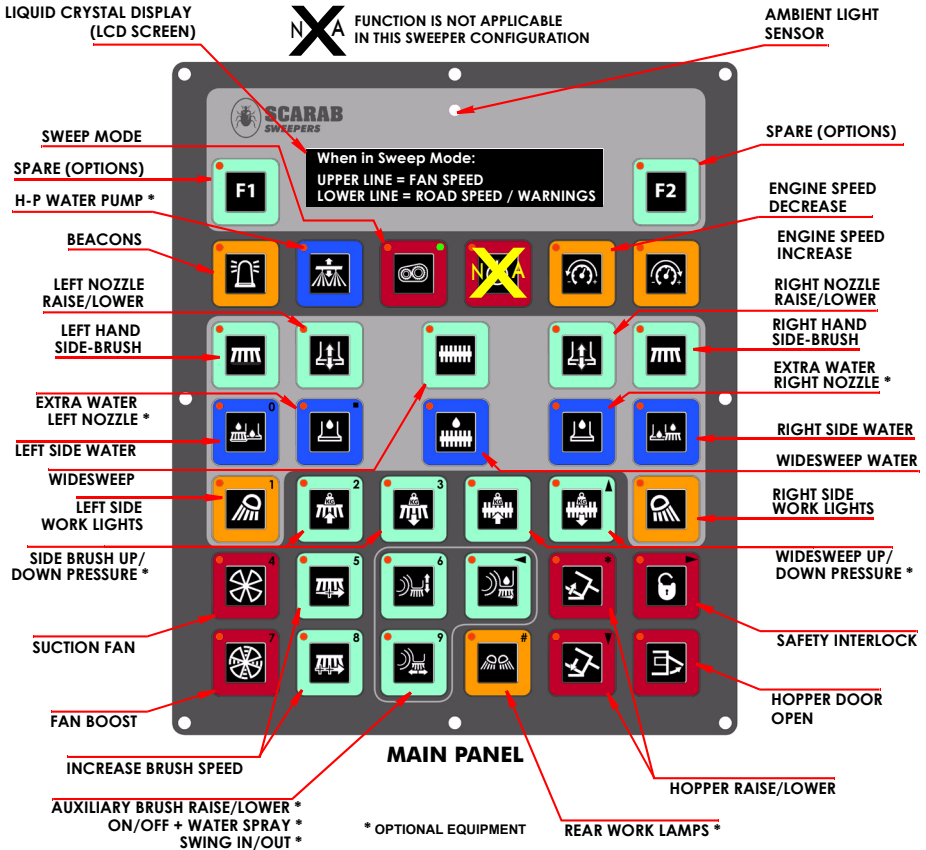

**Fig. 3 Main Control Panel Layout**

**BRUSH SPEED (++) SWITCH** - Press to increase brush speed to 150 rpm. The red LED illuminates when the feature is active. If this feature is selected when Brush Speed (+) is already active it will automatically deselect Brush Speed (+). Press again to revert to normal brush speed.



**FRONT BRUSH SWING IN/OUT SWITCH** - Press to swing the brush out and press again to swing it in. The red LED illuminates while the brush is in the swung OUT position.



**REAR WORK-LIGHTS SWITCH \*** - Press to turn on the rear-mounted work-lights. The red LED illuminates while the feature is active.



**HOPPER LOWER SWITCH** - Press and hold down simultaneously with the safety interlock switch to lower the hopper. the red LED will remain illuminated until the hopper is fully in the lowered position.



**Continued...**

# SCARAB HYDROSTATIC TRUCK-MOUNTED SWEEPERS

**REAR DOOR OPEN SWITCH** - Press and hold down simultaneously with the safety interlock switch to open the rear door. Red LED illuminates when the switch is operated.



**i** Ensure that the suction fan is OFF. The door cannot open while the fan is running due to low pressure in the hopper. External rear door controls are on Page 23.

## THE LCD SCREEN

The LCD Screen provides information on fluid level/temperature warnings and confirmation of sweeper functions.

## AUXILIARY SWITCH PANEL (Located Adjacent To Driver's Door)

**FORWARD/REVERSE LEVER** - Lift collar to release from Neutral and move the lever in the desired direction to activate the hydrostatic transmission. All active functions will stop and/or retract.



**SIDE BRUSH SWING IN/OUT SWITCH** - Press to swing brushes OUT. Press again to swing brushes IN. Red LED illuminates while the brushes are in the swung OUT position. Will also be activated by using the multi-function switch.

**CRUISE CONTROL** - Press to activate cruise control. The red LED illuminates when the feature is selected.

**HIGH-PRESSURE WATER PUMP SWITCH \*** - Press to start the H-P water pump. The red LED will illuminate when the feature is selected. *The switch becomes disabled (symbol not illuminated) and the pump will not operate if the water level in the tank is insufficient.*



**NOZZLE TILT SWITCH (MOMENTARY MODE)** - Press and hold to tilt the suction nozzle for larger items, such as bottles. The red LED illuminates when the switch is activated. Release the switch to revert to cancel.



**FOUR-POSITION MULTI-FUNCTION SWITCH** - Move the switch back (upright position) to turn the Master Switch function ON (deploys all selected sweeping equipment). The LED at the centre of the switch panel illuminates when the Master Switch is active. To stop and raise all sweeping equipment, return the switch to the OFF position.

In the ON position the switch can be used to control additional functions. These positions are detented to the central position:

### ON LEFT HAND DRIVE VEHICLES

Move the switch to the left to swing the side brush(es) OUT.

Move the switch to the right to swing the side brush(es) IN.

### ON RIGHT HAND DRIVE VEHICLES

Move the switch to the right to swing the side brush(es) OUT.

Move the switch to the left to swing the side brush(es) IN.

### NOZZLE-TILT FUNCTION

On machines with hydraulic nozzle-tilt, move the switch back to 'nudge' the suction nozzle DOWN from the LOCKED OPEN position.

On machines with pneumatic nozzle-tilt, move the switch back to momentarily tilt the suction nozzle or close it from LOCKED OPEN.



# SCARAB HYDROSTATIC TRUCK-MOUNTED SWEEPERS

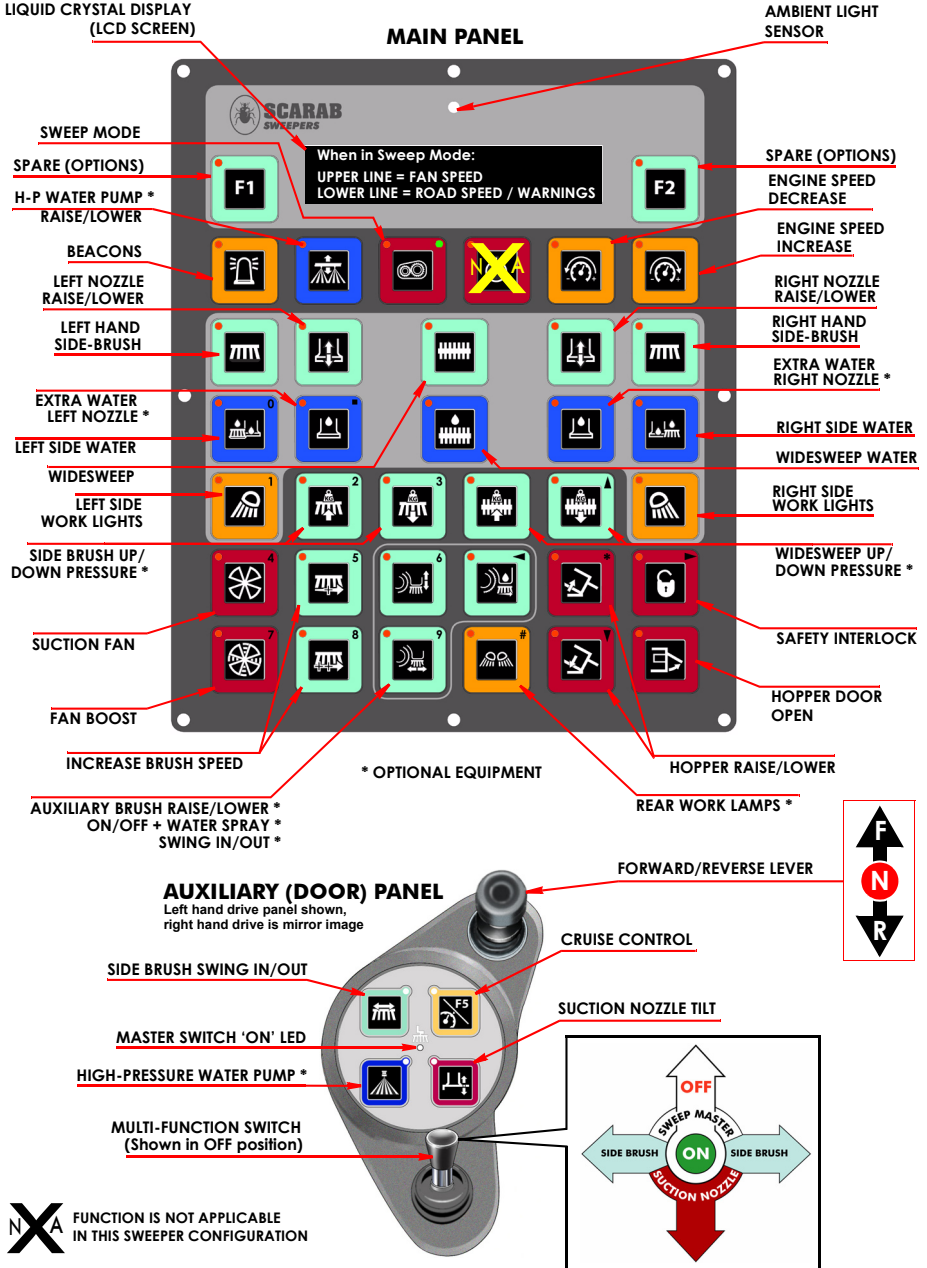

**Fig. 4 Main & Auxiliary (Door) Panel Layouts**

# SCARAB HYDROSTATIC TRUCK-MOUNTED SWEEPERS

## REAR-MOUNTED SUCTION NOZZLE OPTION

It is possible to equip Magnum models with a special hopper door assembly that incorporates a pair of rear-mounted suction nozzles and their associated high-pressure water spray bars. The inclusion of this option in the vehicle specification requires a different main control panel to the standard layout. This involves changes to the two lower-most rows of switches (Refer to Fig. 5). To incorporate the rear nozzle controls the following switches have been relocated:

- Front brush On + Water
- Front brush Raise/Lower
- Front brush Swing IN/OUT

and the following switches have been removed:

- Safety Interlock for Hopper and Rear Door
- Hopper RAISE / LOWER
- Rear door OPEN

To activate the hopper and rear door controls, use the external switches mounted adjacent to the rear side suction tube (refer to Pages 20 to 22).

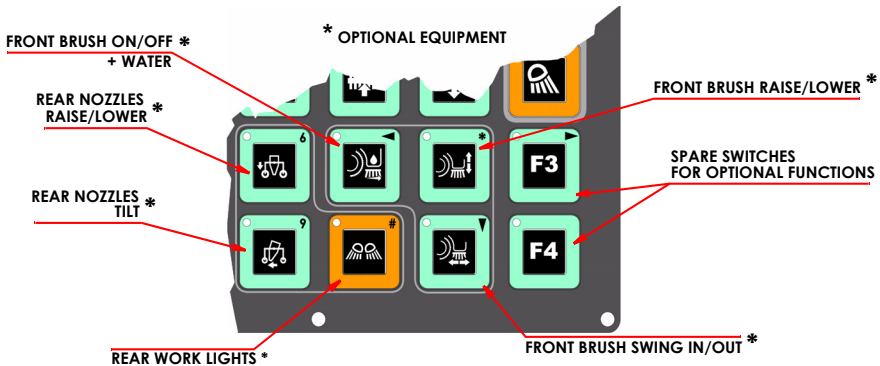

when the Magnum Plus control panel is fitted, it is not possible to accommodate the normal hopper and rear door controls. In these circumstances the hopper and door are controlled using the externally-mounted switches (refer to Pages 20 to 22).

**Fig. 5 Alternative Control Panel layout - Rear-Mounted Suction Nozzles**

# SCARAB HYDROSTATIC TRUCK-MOUNTED SWEEPERS

## ADDITIONAL CONTROLS & INSTRUMENTS



**Do not exceed a pressure of 2.5 bar when adjusting brush pressure settings. Failure to comply will result in drastically reduced brush life.**

### **AIR-PRESSURE REGULATOR \* -**

Used to adjust the amount of up/down-thrust applied to the brush(es) □.

**AIR-PRESSURE GAUGE \* -** Indicates the amount of pressure being applied to the brush(es) □.

- Side-brush regulators/gauges are mounted inside the cab. Widesweep regulators/gauges are located externally to the rear of the near-side suction spigot

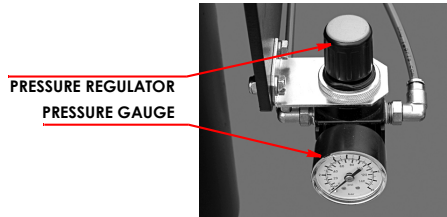

*Externally mounted widesweep pressure controls shown. The side-brush controls are similar but mounted in the cab and positioned according to cab layout or customer preference.*

This function is only effective while the relevant brushes are fully deployed.

### **CONTROLS FOR OVERHEAD WANDER BOOM OPTION -**

These are mounted just above the wander boom handle and consist of two buttons for selecting the fan extra-boost speed (2500 rpm) and/or the low-pressure dust suppression water supply.



*The action of these buttons dictates that a firm application of pressure is required before they can be activated. When activated they will lock in the down (ON) position until released by rotating them in the direction indicated by the arrows.*



## OPERATING MODES

There are two driving modes, Normal & Hydrostatic (Sweep), these are selected using the SWEEP MODE switch on the control panel. This switch has two LEDs, one green and one red. These are used to indicate which drive mode is currently in operation as follows:



- Green = Normal drive mode
- Red = Hydrostatic drive (sweep mode)

## ENGAGING HYDROSTATIC DRIVE

**REFER TO THE HEALTH & SAFETY INFORMATION ON Page 3**



**The engine must be running and the air tanks/pneumatic system must be fully pressurised before attempting to engage hydrostatic drive mode.**



**The hydrostatic gearbox has a motion sensor. This will not allow engagement of hydrostatic drive until the vehicle is stationary.**



1. Switch on hazard warning beacons.
2. Stop the vehicle apply the parking brake and select Neutral.
3. With the engine running, depress the clutch pedal and press the Sweep Mode switch. The switch's LED indicators will change from GREEN to RED, confirming that hydrostatic drive has engaged successfully.
4. Select the highest forward gear available and release the clutch pedal. The vehicle is now in hydrostatic drive and may be driven without use of the clutch.



*If the green LED flashes ON/OFF or you hear gears grating, the drive gears in the transfer box have not meshed correctly. If the clutch is engaged at this point while the parking brake is applied, the engine will probably stall. Refer to Step 5.*

5. If Hydrostatic drive fails to engage, press Sweep Mode to restore Normal Drive mode. Engage first gear, release the hand brake and move the vehicle forward slightly. Repeat Steps 2. to 4.
6. Set the required engine speed by means of the engine speed +/- controls on the main panel.



7. Switch on the suction fan, selecting Normal (approx. 2000 rpm) or Boost (approx. 2200 rpm) as required. If Boost is selected (Page 18) remember that increased engine speed might be necessary. Fan speed can be confirmed by referring to the LCD on the main panel.



8. Select the desired configuration of brushes/suction boxes and water sprays (any combination of brushes and water can be selected). Switch on work-lights as required.

9. Move the Multi-Function Switch (located on the auxiliary control panel) to the Sweep Master Switch ON position to start and deploy the pre-selected sweeping equipment.



# SCARAB HYDROSTATIC TRUCK-MOUNTED SWEEPERS

To stop and stow the sweep gear, return the switch to OFF. The sweeping equipment will raise to the stowed position and all water spray jets will stop.

 This will also occur automatically as soon as REVERSE is engaged, reverting to the original configuration as soon as FORWARD is resumed.

10. Operate the side brush IN/OUT (or multi-function switch) and NOZZLE TILT switches (also on the auxiliary control panel) as required to suit the sweeping conditions.



11. Select Forward drive using the hydrostatic control lever and slowly depress the throttle pedal to start sweeping.

**To revert to Normal Drive mode, repeat Steps 2. to 3. The switch LEDs will change from RED to GREEN.**

## SUCTION FAN BOOST SETTING

When required, a boost setting is available for the suction fan. This increases fan speed by approximately 10% and is used when sweeping densely distributed or heavy debris such as rubble. To operate the fan at the Boost setting, carry out the following procedure:

1. Adjust Engine Speed by means of the controls on the main panel
2. Press the suction fan BOOST switch and refer to the LCD screen to confirm that the fan speed has increased to approximately 2200 rpm.



## CLIMBING GRADIENTS

1. When sweeping up hill it might be necessary to increase engine speed to maintain sweeping performance. It is advisable to do this before you start to climb the hill.



The amount of increase will depend on a range of variable factors:

- (a) The individual characteristics of the engine.
- (b) The current hopper load.
- (c) The current sweeping load (e.g. light or heavy material)
- (d) The angle of the gradient.

To increase engine speed, do one of the following:





- **Use the engine speed-setting controls** (this method is most useful when a prolonged increase in engine speed is required).
- **Use the throttle pedal** to temporarily over-ride the pre-set engine speed (this method is more convenient for brief increases in engine speed).



**Continued...**

# SCARAB HYDROSTATIC TRUCK-MOUNTED SWEEPERS

## SELECTING NORMAL DRIVE MODE

1. To return to Normal Drive, proceed as follows:
  - (b) Bring the vehicle to a complete stop and apply the hand brake.
  - (c) Move the Multi-Function Switch (located on the auxiliary control panel) to the Sweep Master Switch OFF position to stop and lift all sweeping equipment to the stowed position. 
  - (d) Stop the suction fan by pressing the Suction Fan switch. The red LED will extinguish, confirming that the fan is no longer operating. 
  - (e) Depress the clutch and engage Neutral on the truck gearbox.
  - (f) Engine speed will drop to IDLE when the clutch is depressed. if necessary, however, engine speed can be set to IDLE by means of the controls on the main panel. 
  - (g) With the clutch depressed, Press the Sweep Mode switch, holding it down until the LEDs change from red to green. When the green LED is lit the vehicle is in normal drive mode. 
  - (h) As soon as you no longer represent a hazard switch the beacons OFF.

## REDUCING NOISE LEVELS & FUEL CONSUMPTION

Although it is important to always operate within the engine's optimum speed range, there are times when it is possible to reduce engine speed to the lower end of this, thereby reducing noise levels. This is most beneficial when sweeping at night, or in areas sensitive to noise pollution.

Sweeping at reduced engine speeds can be achieved most satisfactorily when sweeping light or sparsely distributed materials. Experience will enable the operator to vary engine speed, according to sweeping conditions, without reducing sweeping performance.

It should be noted that the operator also benefits from reduced noise levels within the cab and that any reduction in engine speed, also results in a corresponding reduction in fuel consumption.

## DISCHARGING THE HOPPER (TIPPING)

### OPERATING THE REAR DOOR



**ENSURE THAT ALL PERSONNEL ARE CLEAR OF THE DOOR.**



Ensure that the suction fan is turned OFF and that there is room for the door to open fully.

Always ensure that door is OPEN before raising the hopper. This will avoid the possibility of causing damage to the door in the event of a heavy load sliding back as the hopper tilts

The Rear Door controls are sited both inside the cab and externally. The in-cab controls are located on the sweeper panel. The external controls are located on the sub-frame above the nearside suction nozzle. They are grouped, in a single switch box, with the hopper controls.

### OPEN DOOR - CAB CONTROLS

With the engine running at IDLE, press and hold down the Safety Interlock button, while simultaneously operating the Door Open switch until the door is fully open.



For safety reasons, it is not possible to close the door using the in-cab controls. Use the external controls.

### OPEN DOOR - EXTERNAL CONTROLS

With the engine running at IDLE and the vehicle in Sweep Mode, hold down, the Door Open button until it is fully open.



### CLOSE DOOR - EXTERNAL CONTROLS



Before closing the door, ensure that the seal, and mating faces on the hopper, are free from any foreign matter that might damage the seal or adversely affect the sealing function.

With the engine running at IDLE and the vehicle in Sweep Mode, press and hold the Door Close button until the door is fully closed and the door-locking ram has completed its locking cycle.



# SCARAB HYDROSTATIC TRUCK-MOUNTED SWEEPERS



## OPERATING THE HOPPER

-  **THE HOPPER PROP MUST ALWAYS BE USED WHEN THE HOPPER IS IN THE RAISED POSITION. FAILURE TO DO SO COULD RESULT IN SERIOUS INJURY. BEFORE RAISING THE HOPPER, ENSURE THAT THE VEHICLE IS ON FIRM, LEVEL GROUND AND THAT THERE ARE NO OVERHEAD OBSTRUCTIONS. DO NOT DRIVE THE VEHICLE WHILE THE HOPPER IS RAISED.**



-  **MAGNUM with Rear Suction Nozzles Only - the hopper will not tilt unless the rear door is in the OPEN position.**

The hopper controls are sited both inside the cab and externally, except Magnum Plus which only has external controls. The in-cab controls are located on the main sweeper panel. The external controls are located on the sub-frame above the nearside suction nozzle. They are grouped, in a yellow 4-gang switch box, with the rear-door controls.

To be able to raise the hopper the following conditions are required:

-  • The engine must be running
-  • Sweep Mode must be engaged

### USING THE IN-CAB CONTROLS

-  1. To raise the hopper, press and hold down the Safety Interlock switch while simultaneously pressing the Hopper UP switch until the hopper is in the fully raised position. When the hopper is raised a warning to this effect is displayed on the control panel's LCD screen.  
 If working under the hopper, deploy the hopper safety prop, ensuring that its foot is securely located in its sub-frame pocket.
2. To lower the hopper, fold (if deployed) the hopper safety prop into its stowage position flush with the hopper base frame.
3. Press and hold down the Safety Interlock switch and Hopper DOWN switches simultaneously until the hopper is fully lowered. When the hopper reaches the fully-down position the LCD screen warning message is cancelled.

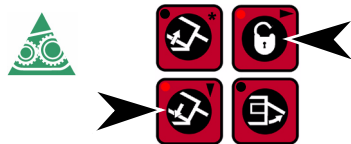
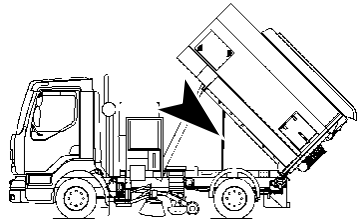
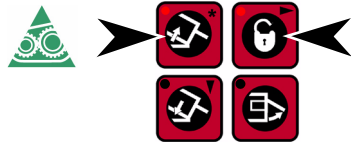



# SCARAB HYDROSTATIC TRUCK-MOUNTED SWEEPERS

## USING THE EXTERNAL CONTROLS

1. To raise the hopper, press and hold the Hopper Raise button until the hopper is in the fully raised position. When the hopper is raised a warning to this effect is displayed on the control panel's LCD screen.

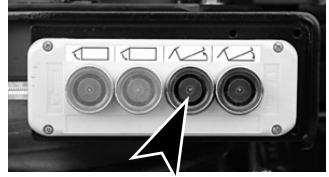

2. Unless discharging, deploy the hopper safety prop, ensuring that its foot is securely located in its pocket on the sub-frame.



**WHEN OPERATING THE HOPPER-LOWER CONTROLS, ENSURE THAT NO PART OF YOUR PERSON, PARTICULARLY YOUR HAND IS IN THE PATH OF THE DESCENDING HOPPER.**

3. To lower the hopper, fold the hopper safety prop into its stowage position flush with the hopper base frame.
4. Press and hold the Hopper Lower button until the hopper is in the fully lowered position. When the hopper reaches the fully-down position the LCD screen warning message is cancelled.

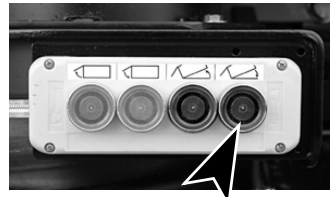

## CLOSING THE REAR DOOR



**Before closing the door, use the hand lance to wash the seal to ensure that the door seal, and mating faces on the hopper, are free from any foreign matter that might damage the seal or adversely affect the sealing function.**



With the engine running at IDLE and the vehicle in Sweep Mode, press and hold the Door Close button until the door is fully closed and the door-locking ram has completed its locking cycle.



**Continued...**

## USING THE AUXILIARY HYDRAULIC PUMP

In the event of hydraulic system failure, an auxiliary (manually operated) hydraulic pump is fitted, to enable the rear door and hopper to be operated manually. This is located on the Left Hand side of the vehicle, adjacent to the hopper suction spigot. The pump handle is stowed in the cab.

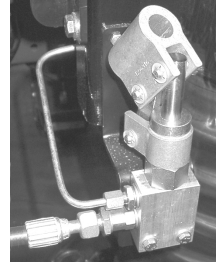

- i** *It will require a substantial number of pumping cycles to complete either of the following operations. The assistance of a second person is highly recommended.*

### REAR DOOR

- ⚡** **Electrical power is required to use the auxiliary pump for this purpose.**

#### TO OPEN THE REAR DOOR

For this procedure, the ignition should be ON and the machine should be in Sweep Mode.

1. If the engine is running, make sure that the suction fan is switched OFF.

- i** *If the fan is operating the door will be unable to open.*

2. If the vehicle's ignition is OFF, turn it ON.
3. Press the Sweep Mode switch to activate the main sweeper control panel.
4. Operate the auxiliary pump, simultaneously pressing and holding the Door Open button (see NOTE) until the door is in the required position.



#### TO CLOSE THE REAR DOOR

- ⚡** **Electrical power is required to use the auxiliary pump for this purpose.**  
**Before closing the door, ensure that the door seal, and mating faces on the hopper, are free from any foreign matter that might damage the seal or adversely affect the sealing function.**

1. Turn the vehicle's ignition ON.
2. Press the Sweep Mode switch to activate the main sweeper control panel.

- 👁** 3. Operate the auxiliary pump, simultaneously pressing and holding the Door Close button, until the door is fully in the closed position.



# SCARAB HYDROSTATIC TRUCK-MOUNTED SWEEPERS

## HOPPER (ELECTRICAL SYSTEM OPERATIONAL)



**THE HOPPER PROP MUST ALWAYS BE USED WHEN THE HOPPER IS IN THE RAISED POSITION. FAILURE TO DO SO COULD RESULT IN SERIOUS INJURY. BEFORE RAISING THE HOPPER, ENSURE THAT THE VEHICLE IS ON FIRM, LEVEL GROUND AND THAT THERE ARE NO OVERHEAD OBSTRUCTIONS. DO NOT DRIVE THE VEHICLE WHILE THE HOPPER IS RAISED.**

### TO RAISE THE HOPPER



1. Ensure that the gearbox is in Neutral.
2. If the vehicle's ignition is OFF, turn it ON.
3. Press the Sweep Mode switch to activate the main sweeper control panel.
4. Fit the pump handle and, while pressing and holding the Hopper Raise button, operate the pump until the hopper has been raised sufficiently to deploy the safety prop.



5. Deploy the hopper safety prop.

### TO LOWER THE HOPPER

The hopper ram is a double-acting unit and will require pumping all the way down.

1. If the vehicle's ignition is OFF, turn it ON.
2. Press the Sweep Mode switch to activate the main sweeper control panel.
3. Stow the hopper safety prop.
4. Fit the pump handle and, while simultaneously pressing and holding the Hopper Down button, operate the pump until the hopper has been completely lowered. The red LED in the hopper RAISE switch on the main control panel will not extinguish until the hopper is completely down.

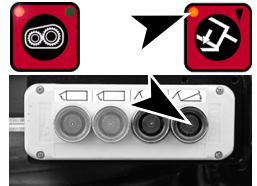

### To Raise /Lower the Hopper, Open/Close the Rear Door on Right Hand Drive Vehicles (with electrical power available)



*Either the foregoing procedure, with the assistance of a second person to operate the external buttons, or the following may be used.*

#### To Raise/Lower the Hopper

1. Ensure that the vehicle's gearbox is in neutral and that the ignition is ON.
2. On the main control panel, simultaneously press switches, marked in red on the accompanying diagram. Fig. 6

**Continued...**

# SCARAB HYDROSTATIC TRUCK-MOUNTED SWEEPERS

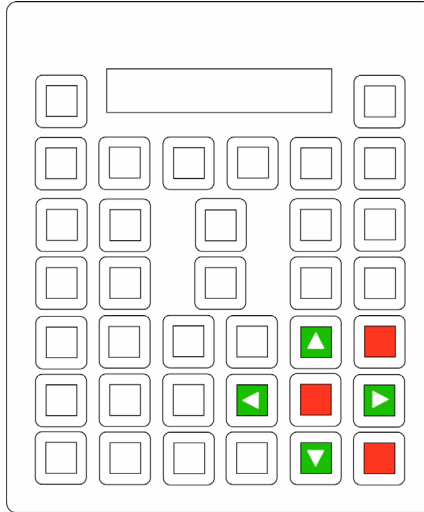

## ARROW KEY FUNCTIONS

- ▶ **ENTER..... (SAFETY INTERLOCK SWITCH)**
- ▶ **EXIT..... (AUX. SIDE BRUSH SWITCH)**
- ▶ **SCROLL UP ..... (WIDESWEEP PRESSURE SWITCH)**
- ▶ **SCROLL DOWN..... (HOPPER DOWN SWITCH)**

**Fig. 6 Using the Main panel in Program Mode**

3. Using the scroll up/down switches, select the HYDRAULIC NODE and press enter then refer to Fig. 7.

Using the up/down switches, scroll to the Hopper Raise line (E1) then press enter to access the Output parameters. Using the up/down switches, scroll to the test line and press enter, TEST-ON should be displayed. With the vehicle left in this condition, proceed to operate the auxiliary hand pump until the hopper is fully raised. **DEPLOY THE HOPPER SAFETY PROP.** SWITCHING OFF THE IGNITION WILL RESET ALL PARAMETERS.

### HOPPER RAISE PROCEDURE

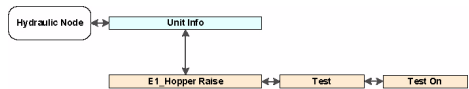

Using the up/down switches, scroll to the Hopper Lower line (F2) then press enter to access the Output parameters. Using the up/down switches, scroll to the test line and press enter, TEST-ON should be displayed. With the vehicle left in this condition, proceed to operate the auxiliary hand pump until the hopper is fully raised. **DEPLOY THE HOPPER SAFETY PROP.** SWITCHING OFF THE IGNITION WILL RESET ALL PARAMETERS.

### HOPPER LOWER PROCEDURE



**Fig. 7 Hopper Raise/Lower Procedure**

# SCARAB HYDROSTATIC TRUCK-MOUNTED SWEEPERS

## To Open/Close the Rear Door

1. Ensure that the vehicle's gearbox is in neutral and that the ignition is ON.
2. On the main control panel, simultaneously press switches, marked in red on the accompanying diagram. Fig. 6
3. Using the scroll up/down switches, select the HYDRAULIC NODE and press enter then refer to Fig. 8.

Using the up/down switches, scroll to the Rear Door Open line (F1) then press enter to access the Output parameters. Using the up/down switches, scroll to the test line and press enter, TEST-ON should be displayed. With the vehicle left in this condition, proceed to operate the auxiliary hand pump until the door is in the required position.

SWITCHING OFF THE IGNITION WILL RESET ALL

Using the up/down switches, scroll to the Rear Door Closed line (G1) then press enter to access the Output parameters. Using the up/down switches, scroll to the test line and press enter, TEST-ON should be displayed. With the vehicle left in this condition, proceed to operate the auxiliary hand pump until the door is in the fully closed position.

SWITCHING OFF THE IGNITION WILL RESET ALL PARAMETERS.

### REAR DOOR OPEN PROCEDURE



### REAR DOOR CLOSE PROCEDURE



**Fig. 8 Rear Door Open/Close Procedure**



*If the electrical system is not operational, refer the matter to your supervisor or service department as appropriate.*

## WANDER HOSE & WANDER BOOMS

Scarab truck-mounted sweepers are equipped with either the standard wander hose, or the optional rear-mounted Wander Boom.

### USING THE WANDER HOSE

1. Move the Multi-Function Switch (located on the auxiliary control panel) to the Sweep Master Switch OFF position to stop any active equipment. The suction nozzle blanking flaps will remain open.
2. If the fan is running, deselect it and allow it to run down. The red LED on the switch will extinguish.
3. When the fan has stopped, remove the blanking plate from one of the apertures in the rear door, stowing it on the captive fasteners.
4. Attach the wander hose over the aperture, using the captive fasteners. A second operator can use the wander hose during normal sweeping operations.



**i** For situations requiring maximum suction power, such as when clearing gully pots, select fan boost-speed and blank off the suction nozzles as follows:

5. Deselect any active suction nozzle(s). This will close the nozzle blanking flap(s). The switch LED(s) will extinguish.
6. Press the suction fan switch to restart the fan, followed by the fan boost switch. The red LEDs will illuminate. The wander hose is now ready for use.



### USING THE REAR-MOUNTED/OVERHEAD WANDER BOOMS

On machines fitted with either optional wander boom arrangement, the wander hose is permanently fitted. On the rear-mounted boom the weight of the hose/nozzle is partially supported by a gas strut, on the overhead boom the hose/nozzle and main tube are supported by a coil spring arrangement. The wander booms are equipped with their own dust suppression system and blanking flap. As with the standard wander hose, both versions of the wander boom can be used while sweeping.

**i** For situations requiring maximum suction power, such as when clearing gully pots, select fan boost-speed and blank off the suction nozzles as follows:

1. Deselect any active suction nozzle(s). This will close the nozzle blanking flap(s). The switch LED will extinguish.
2. Demount the hose assembly from its stowage as detailed at Fig. 9 and swing-out the entire assembly to the required position.
3. Operate the wander boom controls as detailed at Fig. 9). The appropriate blanking flap will open and the dust suppression spray jets will start. The wander boom is now ready for use.



# SCARAB HYDROSTATIC TRUCK-MOUNTED SWEEPERS

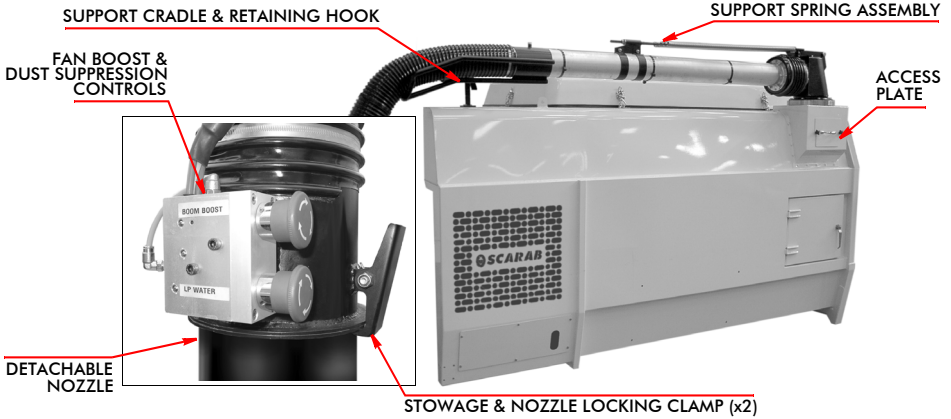

## STANDARD WANDER HOSE

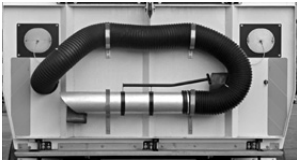

## REAR-MOUNTED BOOM ASSEMBLY

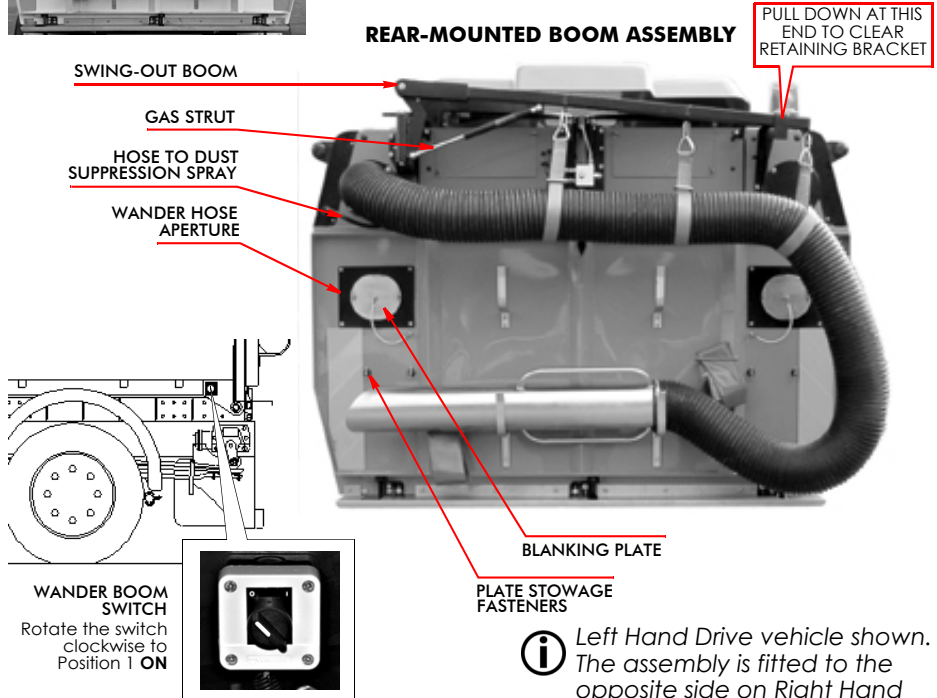

**i** Left Hand Drive vehicle shown. The assembly is fitted to the opposite side on Right Hand

**Fig. 9 Wander Hose & Boom Arrangements**

**Continued...**

## USING THE LOW-PRESSURE WATER PUMP



**Unless the ground is wet, always use the dust suppression sprays.**

Before using the dust suppression system, ensure you have sufficient water in the tank. Select the spray jets and sweep pattern you require. Press the Brush Master Switch (in Sweep Mode) to start the selected configuration.

Press the appropriate switches on the sweeper panel to start the water spray for each item of sweeping equipment as follows:



*Individual spray jets can be isolated by using the valve on each supply hose.*

**Side-brush & Suction Box** - To start either or both the left hand or right hand spray nozzles, press the appropriate side-brush/suction nozzle water switches. The red LED will illuminate to confirm the feature is active.



**Widesweep Brush** - To start the widesweep spray nozzles press the widesweep water switch. The red LED will illuminate to confirm the feature is active.



**Suction Box - Dust Suppression (Optional)** - Press the suction box Additional Water Spray switch. The red LED will illuminate to confirm that the feature is active.



## LUBRICATION

The main bearings are 'sealed-for-life' and require no lubrication, however, on some pumps the crankcase void is provided with a grease nipple (the schedule on Page 33 gives frequency of applications).

## DRAINING

1. It is vital that the strainer and pump are totally drained whenever the air temperature is expected to fall to 0° C or below. If allowed to freeze it is likely that damage will be incurred.
2. Drain the water tank and open the drain valve (Fig. 10). Switch on all sprays and run the water pump until the system runs dry.

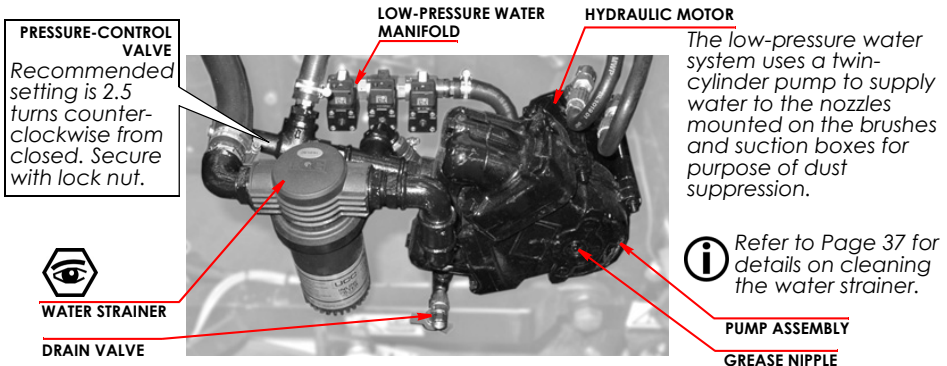

**Fig. 10 Typical Low-pressure Water Pump Arrangement**



# SCARAB HYDROSTATIC TRUCK-MOUNTED SWEEPERS

## USING THE OPTIONAL HIGH-PRESSURE WATER PUMP



HIGH PRESSURE WATER CAN BE HAZARDOUS, ALWAYS WEAR GOGGLES OR SUITABLE EYE PROTECTION WHEN OPERATING WITH HIGH PRESSURE WATER. EXERCISE EXTREME CARE WHEN USING THE LANCE, DO NOT DIRECT THE JET AT OTHER PEOPLE. WHEN CLEANING PUBLIC BUILDINGS OR STREET FURNITURE, ENSURE THAT NO ELECTRICAL CONNECTIONS ARE EXPOSED. FAILURE TO COMPLY CAN RESULT IN SERIOUS INJURY.



Do not direct the high pressure jet directly at paint work or at electrical connections, this could result in damage to the vehicle.

This pump should NEVER be permitted to run dry, as this will quickly destroy the piston seals and cause the pump to fail. If the pump shuts off in-use the most likely cause will be low water activating the auto shut-off float switch in the tank.



1. Ensure that there is sufficient water in the water tank.
2. Select Sweep Mode and set engine speed to the high end of its optimum range.
3. If the machine is fitted with a front-mounted high-pressure spray bar, adjust the ball valve to supply the spray bar or the hand-lance as required.
4. Switch on the high pressure pump. The red LED will illuminate to confirm that the feature is active.

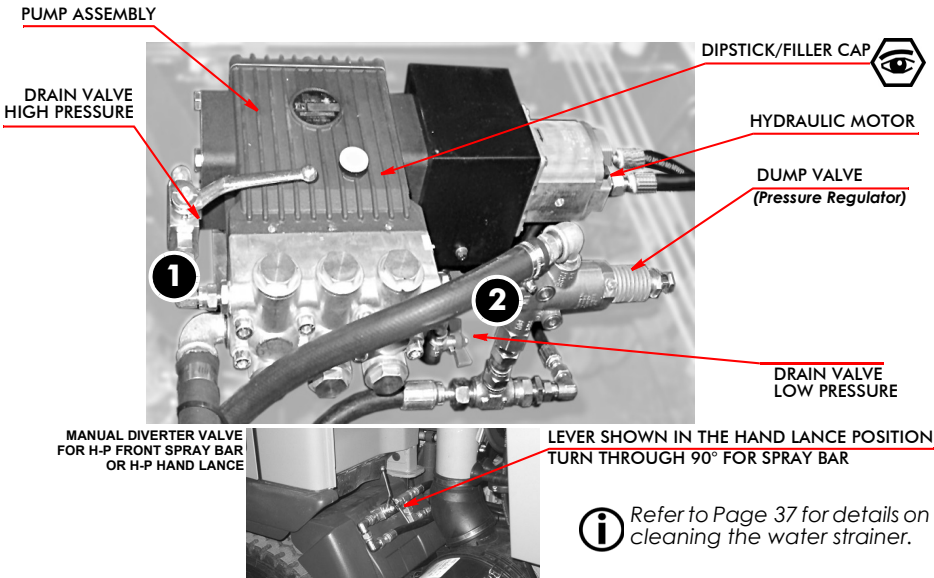

**Fig. 11 Typical High-pressure Water Pump Arrangement**

# SCARAB HYDROSTATIC TRUCK-MOUNTED SWEEPERS

## OIL LEVEL



1. The level of the oil in the pump's crankcase should be checked on a regular basis (See "RECOMMENDED OPERATOR'S ROUTINE MAINTENANCE" on page 33.) and topped up as necessary. There is a combined filler cap/dipstick on the top of the pump body (Refer to Fig. 11).

## DRAINING



**This pump should NEVER be permitted to run dry. Failure to comply will quickly destroy the piston seals causing the pump to fail.**

1. It is vital that the pump is drained of all water whenever the ambient temperature is expected to fall to 0°C or below. If the pump is allowed to freeze it is likely that damage will be incurred resulting in seizure.
2. Drain the water tank (refer to RECOMMENDED OPERATOR'S ROUTINE MAINTENANCE on page 33),
3. To drain the high-pressure side of the pump, open the H-P drain valve (1).
4. To drain the low-pressure side of the pump, open the L-P drain valve (2).

## OPTIONAL SUCTION FAN WASH-ASSIST SYSTEM



**DUE TO THE POSSIBILITY OF EXCESS WATER AND LOOSE MATERIAL BEING EJECTED VIA THE HOPPER HOOD WHEN THE SUCTION FAN IS RESTARTED, THIS PROCEDURE SHOULD ONLY BE CARRIED OUT AT AN APPROPRIATE LOCATION.**

This system comprises a supply hose from the H-P pump, which terminates at a spray nozzle in the suction fan case, and a control valve mounted on the nearside of the vehicle, at the rear, adjacent to the door locking ram assembly.

This system is not intended as an alternative to the normal fan cleaning procedures (see Page 35), but as an aid to this process.

Regular use of the system will greatly enhance fan performance by reducing the rate at which dirt is allowed to build up on the impeller blades and fan case. As such, it is suggested that this system is used immediately following a days sweeping (**or more often if sweeping in particularly arduous conditions**).

Routine fan inspection and cleaning procedures should always take place at the recommended intervals (refer to Page 33).

## OPERATION



1. Ensure that there is sufficient water in the water tank.
2. Select Sweep Mode and set engine speed to the high end of its optimum range.
3. If the machine is fitted with a front-mounted high-pressure spray bar, adjust the control valve to OFF (hand-lance position).



# SCARAB HYDROSTATIC TRUCK-MOUNTED SWEEPERS

4. Set the wash-assist valve to the ON position and switch on the high-pressure pump. The fan-wash jet will start.
5. With fan-wash still running, turn the Suction Fan ON and wait until clear water is being ejected. Return the control valve to the OFF position, stop the High-pressure Pump and then stop the Fan.

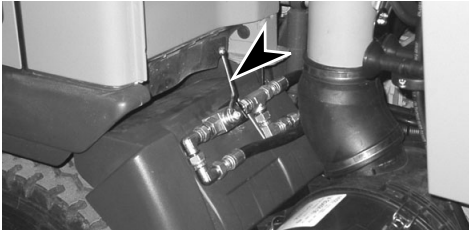

FRONT H-P SPRAY BAR CONTROL VALVE 'OFF'

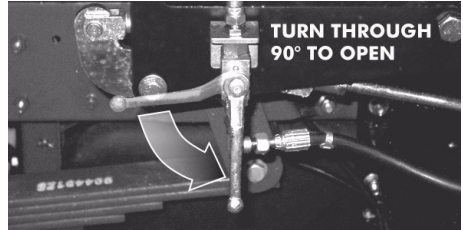

SUCTION FAN WASH-ASSIST VALVE 'ON'

**Fig. 12 Operating the Suction Fan Wash-assist System**

**LOOSE PARTICLES FROM THE CLEANING PROCESS CAN BE EJECTED FROM THE FAN CASING VIA THE HOPPER COVER WHEN THE FAN IS RESTARTED. ENSURE THAT THE AREA AROUND THE MACHINE IS CLEAR BEFORE RESTARTING.**



6. Operate the Suction Fan switch to turn the fan ON. This will clear the water and any loose material from the fan case.
7. Return the Suction Fan switch to the OFF position.
8. Set engine to IDLE and turn OFF (if hot allow to IDLE for 2 minutes before turning off). If appropriate, remove the ignition key.



# SCARAB HYDROSTATIC TRUCK-MOUNTED SWEEPERS

## RECOMMENDED OPERATOR'S ROUTINE MAINTENANCE

It is important that the following routine maintenance procedures are carried out as directed. This will help to ensure that your Scarab sweeper performs at the optimum level of safety and efficiency. Refer to the paragraphs immediately following this schedule and to the Table of Contents (Page 2) for more detailed information.

MAINTENANCE PROCEDURE	DAILY ACTIONS		WEEKLY
	BEFORE USE	AFTER USE	
Using the truck manufacturer's handbook, as necessary, check vehicle / body for safety. All lights, tyres, fuel, oil, coolant, brake fluid, screen wash and water-tank levels. Rectify or report as necessary.	✓	✗	✗
Check hydraulic oil level and inspect vehicle for signs of hydraulic leaks. Check oil cooler and radiator are clean. Rectify as necessary.	✓	✗	✗
If vehicle not previously used by YOU, check suction fan is clean. Rectify or report as required.	✓	✗	✗
Check brushes/skirts for wear. Remove any entangled items, e.g. lengths of string	✓	✗	✗
Check suction nozzle/flaps for damage/correct ground clearance. Wrong settings will degrade suction performance.	✓	✗	✗
Check water spray jets for blockages.	✓	✗	✗
Check all equipment is stowed and brushes have been raised.	✓	✗	✗
Wash vehicle, particularly hopper screens, surrounding ledges and area above. Leave hopper door partially open, to allow air to circulate. Do not direct high-pressure water at electrical connections.	✗	✓	✗
Wash oil cooler, ensuring that the fins are clean	✗	✓	✗
Lubricate as appropriate, all brush links, pivots and nozzle wheels.	✗	✓	✗
Remove / clean the water filter elements	✗	✓	✗
Grease prop. shafts and check for wear at the U/Js.	✗	✗	✓
Grease the Hopper Ram (Top & Bottom)	✗	✗	✓
Visually check entire machine for wear/damage. Rectify or report as required	✗	✗	✓
Clean the suction fan thoroughly, using scraper provided and, if necessary, high-pressure water.	✗	✗	✓
Conduct a thorough inspection of the fan assembly to verify its condition. Report any defects.	✗	✗	✓
Raise & prop hopper. Run fan/brushes (normal speed). Where fitted, check the oil tank return filter gauge, if in the RED zone, replace filter element.	✗	✗	✓

# SCARAB HYDROSTATIC TRUCK-MOUNTED SWEEPERS

Check for wear in suction tubes & deflectors. Report any defects.	✗	✗	✓
Check seals on hopper-door, side-hatches, suction-tubes. Report defects.	✗	✗	✓
Check hopper and subframe-to-chassis mounting points. Report any defects.	✗	✗	✓
Check wiring and hoses for security of attachment and for signs of chafing. Rectify or report defects as necessary.	✗	✗	✓
Check oil level in high-pressure pump, top up as necessary.	✗	✗	✓
Grease rear door hinges and locking bar.	✗	✗	✓
Check the air cleaner element (more often if working in dusty conditions). Clean/replace or report as appropriate.	✗	✗	✓

## LOW-PRESSURE WATER PUMP WHEN FITTED WITH A CRANKCASE GREASE NIPPLE

Using a hand operated grease gun apply two or three pumps after every 300 operating hours. Do not inject more grease than this because over-filling the crankcase can result in damage to the diaphragms.

### IN FROSTY WEATHER



#### CAUTION

**Do not, under any circumstances, operate the high pressure pump without water.**

Drain the water tank (via the drain cock if fitted or by removing the water strainers).

Open the drain taps on each water pump.

Switch on the water sprays and run the low pressure pump until dry.

Remove the water-strainer elements.

Leave the hopper slightly raised with rear & side doors slightly open. This allows air to circulate and prevents damage caused by seals freezing to their mating faces.



*The foregoing are general recommendations only. Requirements vary from territory to territory and depend on vehicle usage/operating conditions. IF IN DOUBT, CONSULT YOUR NEAREST DEALER.*

*Detailed instructions covering the servicing of your Scarab sweeper are published in **Scarab Workshop Manual Z028603**.*

*The fitting of genuine Scarab parts is highly recommended. The use of alternatives might compromise the performance and reliability of your sweeper and could invalidate your warranty.*

*For chassis servicing/maintenance, refer to the chassis manufacturer's information or consult the manufacturer's agent or dealer.*

## KEY MAINTENANCE PROCEDURES

### CLEANING THE SUCTION FAN AND SCREENS



FAILURE TO COMPLY WITH THE FOLLOWING COULD RESULT IN SERIOUS INJURY.

1. BEFORE WORKING ON THE MACHINE POSITION IT ON FIRM, LEVEL GROUND, APPLY HANDBRAKE AND, IF REQUIRED, RAISE THE HOPPER, STOP ENGINE & REMOVE IGNITION KEY.
2. ALWAYS USE THE HOPPER PROP TO SUPPORT A RAISED HOPPER.
3. THE FAN IS AN EXTREMELY HEAVY ROTATING MASS. NEVER ATTEMPT TO SLOW OR STOP ITS ROTATION BY USING THE HANDS OR BY INSERTING ANY ITEM INTO THE FAN CHAMBER, EVEN AT LOW SPEEDS.
4. BEFORE REMOVING THE SUCTION FAN ACCESS PANELS, ENSURE THAT THE ENGINE IS OFF AND THAT THE IGNITION KEY HAS BEEN REMOVED.
5. ALWAYS WEAR SUITABLE EYE & HAND PROTECTION.



1. Remove the outer inspection cover from the hopper and the inner cover from the fan housing to expose the fan (Refer to Fig. 13).



*It is advisable to lower the hopper screens to allow displaced material, from the fan cleaning process, to drop into the hopper.*

*It will be necessary to prevent the fan from rotating while using pressurised water or steam to assist the cleaning process.*

2. Using the special scraper, thoroughly clean all parts of the fan.
3. A steam-cleaner or high-pressure water from a remote source will greatly assist in cleaning severely contaminated fans (see also use of the optional Fan Wash-assist system on Page 31).
4. Clean the screens using steam or high-pressure water.

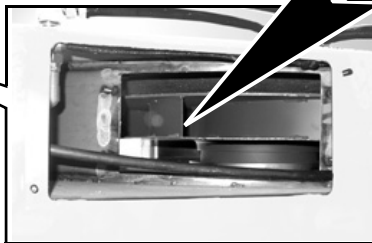
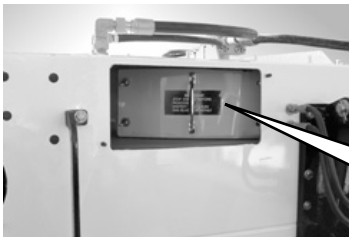

**PLEASE PAY PARTICULAR ATTENTION TO INNER CURVE OF BLADES AND ALSO THE CENTRE OF THE UNIT WHERE DIRT ACCUMULATES AROUND THE HUB AREA**



**Fig. 13 Inspecting & Cleaning the Suction Fan**



5. Refit the inspection covers and lower the hopper.
6. Refit the screens.



**LOOSE PARTICLES FROM THE CLEANING PROCESS CAN BE EJECTED VIA THE HOPPER COVER WHEN THE FAN IS RESTARTED, ENSURE THAT ALL PERSONNEL ARE CLEAR BEFORE RESTARTING.**

7. Start the engine and switch the suction fan ON.
8. With the rear door shut, direct additional water onto the screens below the fan inlet cone, from an open side-access flap, until only clean water is expelled from the fan casing.

# SCARAB HYDROSTATIC TRUCK-MOUNTED SWEEPERS

## SUCTION NOZZLE CLEARANCES

Inspect the suction nozzle flaps to verify that they are in good condition and do not show excessive wear. Adjust as necessary to achieve the correct flap to ground clearances (Refer to Fig. 14).

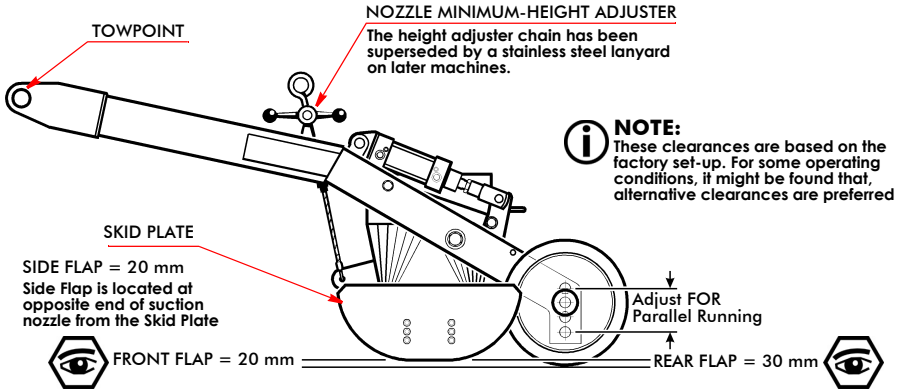

Fig. 14 Suction Nozzle Clearance - Factory Set-up

## SIDE BRUSHES & SKIRTS



**DO NOT ATTEMPT TO ALTER THE BRUSH SETTINGS WHILE THE BRUSH IS ROTATING.**

An effective brush set-up ensures good sweeping performance. The following settings produce excellent results in most conditions. Experience will determine if other settings are better suited to specific conditions.

1. The brush should be angled so that it sweeps with its outer leading edge. About 33% (120°) of its circumference should be in contact with the road surface.
2. The skirt adjacent to the brush, which positions material for the suction nozzle, should also be in good condition and set so that it just clears the ground.

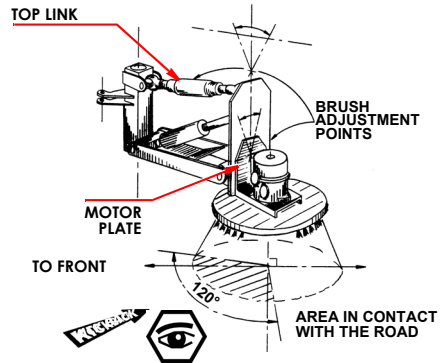

Fig. 15 Brush Tilt Adjustment

# SCARAB HYDROSTATIC TRUCK-MOUNTED SWEEPERS

## DRAINING & CLEANING THE WATER PUMP STRAINERS

Both the low-pressure and, if fitted, the high-pressure water pump are fitted with strainers to ensure that foreign matter does not enter the pump. The following steps detail the recommended cleaning procedure.

**i** If removing the strainer for cleaning while there is water in the water tank, ensure that the isolating stopcock is turned off. If this step is not taken it is possible to lose the filter bowl O-seal as water will drain from the tank with some force via the filter unit as soon as the bowl is released.

1. Remove the strainer from the filter body by removing the filter bowl at the same time taking care to ensure that the O-seal in the filter housing is retained for future re-assembly.
2. Remove the strainer and thoroughly wash clean.
3. Before re-assembling the strainer, apply some grease to the O-seal to ensure a water-tight fit for the filter bowl.
4. Refit the strainer element noting that it must be installed with the white plastic foot at the base (i.e. furthest from the filter housing).
5. Refit the filter bowl, ensuring that the O-seal nests properly in its groove, before hand-tightening the filter bowl.
6. Return the stopcock to the ON position.

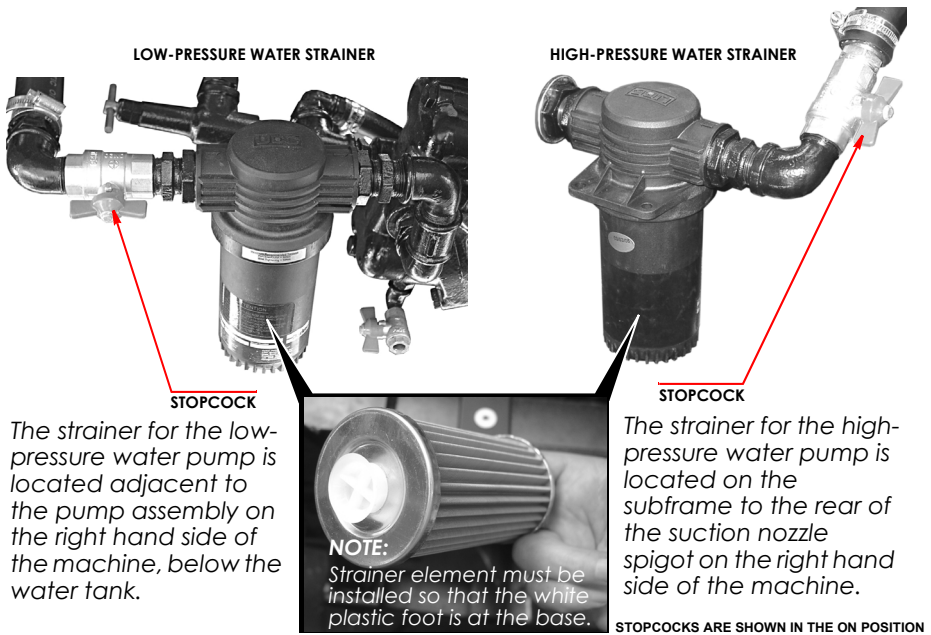

**Fig. 16 Water Pump Strainer Arrangements**



# SCARAB HYDROSTATIC TRUCK-MOUNTED SWEEPERS

## MANUAL GREASING & LUBRICATION

Carry out manual greasing in accordance with the appropriate schedule (Page 33), and by referring to Fig. 17.

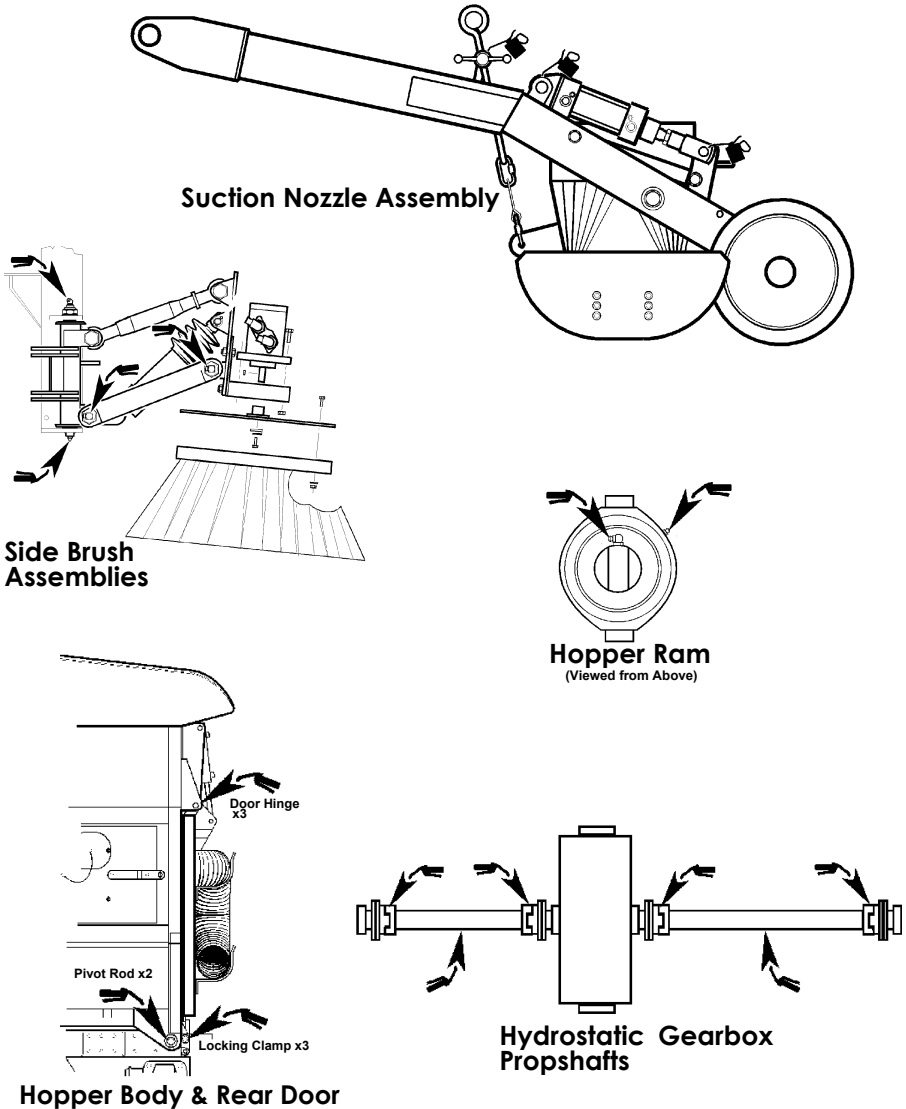

**Fig. 17 Grease-point Locations**

# SCARAB HYDROSTATIC TRUCK-MOUNTED SWEEPERS

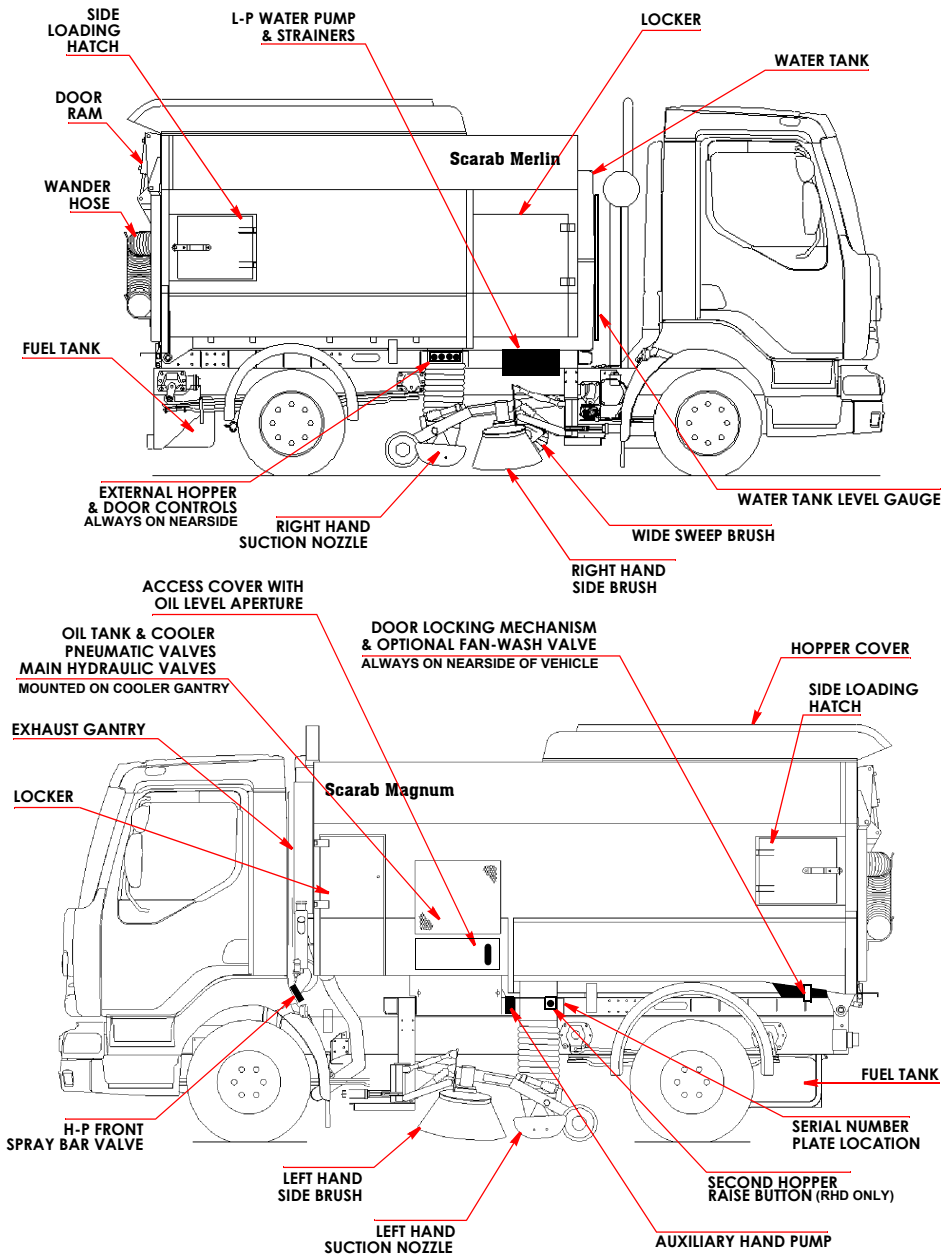

**Fig. 18 Main Features of a Typical Scarab Truck-mounted Sweeper**

# SCARAB HYDROSTATIC TRUCK-MOUNTED SWEEPERS

## RECOMMENDED LUBRICANTS AND CONSUMABLE PARTS

DESCRIPTION	SPECIFICATION	QUANT	SCARAB PART
Hydraulic Oil	Derwent 32	5 litres	005005
Hypoid Gear Oil (Scarab Transfer Box)	85W/90	5 litres	005003
Multi-purpose grease (Grease Points)	Super Lithium 2	400 g	005007
Motor Oil (for High-pressure Water Pump)	15W/50	5 litres	005001
Pneumatic Lubricant	Scarab approved	50 ml	005046
Replacement Widesweep Brush Discs (400 mm Dia)	Normal Brush Extended Brush	33 45	023474
Replacement Widesweep Brush Discs (300 mm Dia)	Standard Brush Extended Brush	33 45	023471
Replacement Spacers (Widesweep)	-	32/44	023472
Replacement Side Brush	315 mm Dia	1/2	023470
Replacement Side Brush	400 mm Dia	1/2	014066
Rubber Skirt, Side Brush	2 slot	1	012216
Rubber Skirt, Side Brush	3 slot	1	010247
Rubber Skirt, Side Brush	5 slot		014069
Front Skirt, Wide Sweep	Standard Brush	1	022516
Front Skirt, Wide Sweep	Extended Brush	1	014069
Suction Tube	-	1	023154
Flap Kit, Suction Nozzle	-	Set of 3	024550
Clamp (Long), Suction Nozzle	-	2	013025
Clamp (Short), Suction Nozzle	-	1	013024
Seal, Suction Nozzle - Hopper	-	1	013601
Seal, Rear Door	-	1	010544
Seal, Side Loading Hatch	-	2	013599
Wander Hose (trunking only)	-	1	025214
Element, Hydraulic Return Filter	-	1	013125
Element, Water Filter	Banjo Type	1	010121
Element, Water Filter	UCC Type	1	023863

### FLUID LEVELS

For checking/topping up the chassis engine's fluid reservoirs, refer to the manufacturer's documentation.

The hydraulic oil level sight glass and filler are located on the left hand side of the machine.

**Access requires the hopper to be in the raised position.**

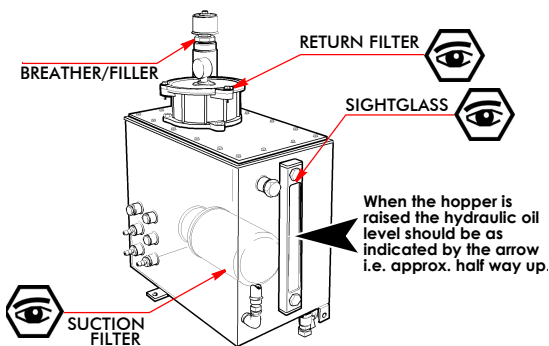

**Fig. 19 Hydraulic Tank**

## LEGIONELLA STATEMENT

### BACKGROUND

There is a growing awareness, through education and publicity, of LEGIONELLA (Legionnaires Disease). This is a respiratory disease, contracted by inhaling small droplets of contaminated water.

Concerns have been raised with regard to the possibility that the water supply system in road sweepers could be a breeding ground for Legionella bacteria, which occur naturally in fresh water, sea water and moist natural environments throughout the world. They do not become a health hazard until they have multiplied.

The conditions that are conducive to the multiplication of Legionella bacteria are:

- A water temperature between 20°C and 45°C.  
*Legionella bacteria cannot grow below 20 °C.*  
*Legionella bacteria cannot live above 60 °C.*
- The presence of sludge, rust, algae etc. in the storage tank or filtration system.
- Direct sunlight.

### RECOMMENDATIONS

The water dust-suppression system used on all Scarab sweepers is of a TOTAL LOSS type i.e. there is no re-cycled water stored on the vehicle.

Provided that the water tank is replenished regularly with mains water, the risk of the bacteria growing is low, however, it might be prudent to take the following basic precautions:

- Drain the water system at the end of the working day, especially in hot weather.
- Flush/clean out the water tank and filtration system regularly to remove sludge, debris, algae etc.
- Ensure that, if the pipe work has been modified, there are no 'dead legs' (i.e. no water flow) where the bacteria might grow.

After discussions with the UK Health & Safety Executive, the Scarab water system, is considered to be LOW RISK as it does not have any heaters, is not used for cooling and is not recycled.

The foregoing advice is for guidance purposes only. For further information or advice it is recommended that you consult your local environmental health authority.

**OPERATOR'S NOTES**

# SCARAB HYDROSTATIC TRUCK-MOUNTED SWEEPERS

---



***Scarab Sweepers Limited***  
**Pattenden Lane, Marden, Kent TN12 9QD**

Telephone: 01622 831006

Fax: 01622 832417

International: +44 (0)1622 831006

International +44 (0)1622 832417

e-mail: [scarab@scarab-sweepers.com](mailto:scarab@scarab-sweepers.com)

Web site: [www.scarab-sweepers.com](http://www.scarab-sweepers.com)