

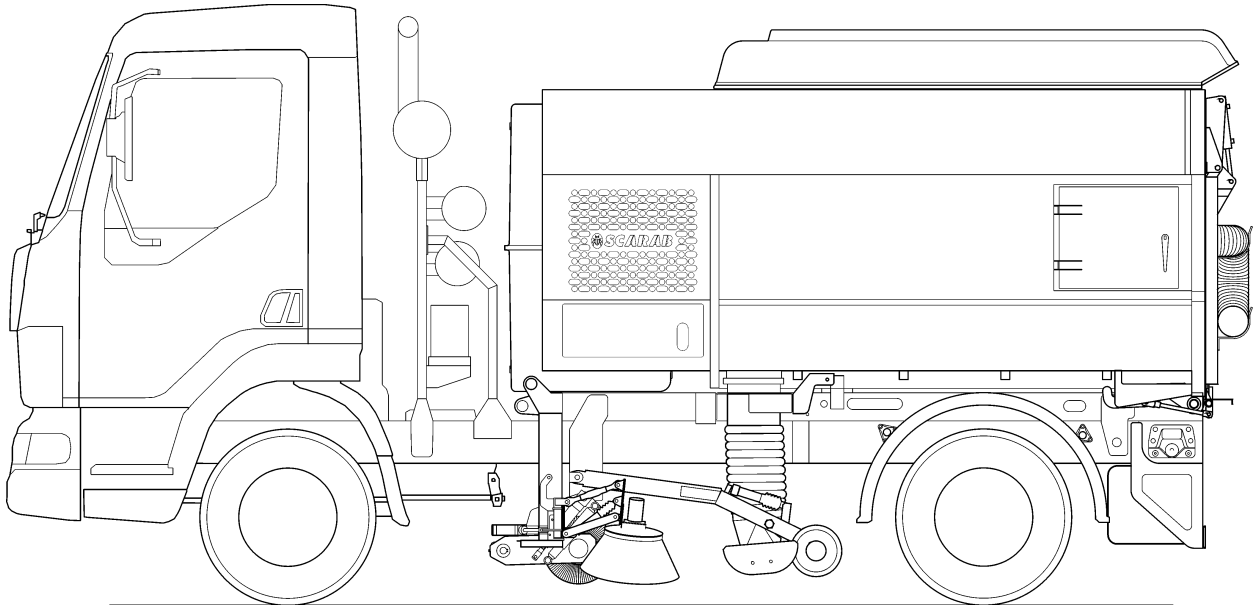

Scarab Merlin XP Unidrive



The Scarab Unidrive System

The Merlin XP Unidrive advanced 7.5 tonne GVW truck-mounted Road Sweeping Vehicle has been developed to maximise the payload potential for the still-popular 7.5 tonne GVW sector. As with its heavy-duty siblings, the Merlin XP Unidrive is based on Scarab's proven 'Single Engine' concept and incorporates the latest Scarab Unidrive technology. The unique Unidrive PTO powers the suction fan, sweeping brushes and auxiliary services. Slow sweeping speeds are afforded by the chassis' own transmission combined with the Scarab reduction gearbox. All Scarab sweepers are designed to deal with the most arduous conditions and the Merlin XP provides the operator with a machine offering the LARGEST PAYLOAD available for the 7.5 tonne chassis, together with a minimum of moving parts for reduced servicing. By utilising just the chassis engine, which conforms to the very latest stringent emission legislation, the operator is able to achieve significant REDUCTION of EXHAUST POLLUTION and FUEL CONSUMPTION, making the latest Scarab Merlin XP Unidrive one of the most environmentally friendly, high-performance 7.5 tonne truck-mounted road sweepers available anywhere in the world.

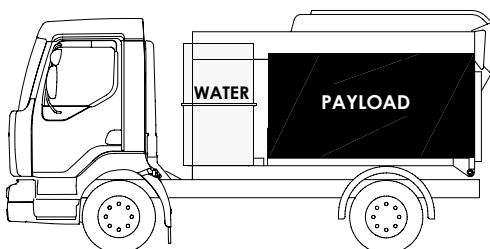

Twin Engine 7.5 tonne Sweeper

- Restricted payload
- Higher operating costs
- Higher fuel consumption
- Clutch and brake wear
- Reduced road-speed control

Scarab Merlin XP 7.5 tonne Unidrive Sweeper

- Increased payload
- Simplified drive system
- Reduced servicing and operating costs
- Reduced fuel consumption
- Finite road-speed control
- Reduced environmental impact

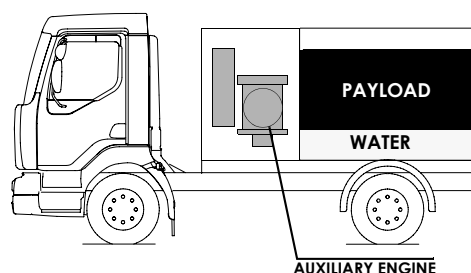

SCARAB UNIDRIVE: Utilising the manual transmission of the chassis and the Scarab-manufactured reduction gearbox in the drive-line, the Scarab Merlin XP Unidrive allows the operator to sweep at a wide range of speeds, dependent upon operating conditions. Typically, this ranges from 0.8 mph (1.1 km/h) to maximum vehicle speed. A robust engine-driven PTO supplies the power to drive the suction fan and brushes via hydraulic pumps. The reduction gearbox is operated by a pneumatic gear-change. This is controlled from the main CANbus panel, via motion sensors to prevent engagement while the vehicle is moving.

SUCTION FAN: The dynamically balanced 900 mm diameter suction fan is mounted in the hopper top and, as with all Scarab sweepers, is powered by a load-sensing pump to give the highest performance and efficiency while minimising noise level. The impellor is a highly efficient multi-blade centrifugal unit, giving a nominal airflow of 6000 ft³/min. (170 m³/min.). Mounting the fan on the hopper top creates a virtually straight airflow from the suction nozzles. This makes the Scarab Merlin XP extremely efficient and significantly reduces power requirements. Two operating modes are provided, Standard Mode for normal sweeping and Boost Mode which increases suction power by 30%, for more arduous conditions.

SUCTION NOZZLE: Of all-steel construction, the 740 mm wide suction nozzle is mounted in a trailed frame running on 250 mm diameter rubber tyred wheels. A 250 mm diameter suction hose connects the nozzle to the hopper. Easily replaced adjustable rubber flaps and a skid plate are used to form the nozzle inlet and the high suction performance makes feasible a flap to ground clearance of 25–30 mm resulting in a long flap life and less need for adjustment. Four manually adjustable water spray jets are fitted to the nozzle at 90° intervals to provide an internal dust suppression spray. Additional water injection nozzles are available when required. An optional 4-jet water boost bar can also be fitted in front of suction nozzle for use in extreme conditions. A tilting mechanism, controlled by a pneumatic ram, enables the suction nozzle to accommodate large objects or autumn leaf build-ups with ease.

SIDE BRUSH: 500 mm diameter steel-tined quick-change brush with direct drive hydraulic motor, fitted with trailed linkage, kick back protection, pneumatic ram for in/out control, fully adjustable for brush angle, three speed control (nominally 100 / 125 / 150 RPM). Optional brush pressure control is available. A work light is fitted to assist with low light operation.

WIDE SWEEP: 320 mm diameter quick-change polypropylene segments with direct drive hydraulic motor, fully floating with shock absorbers to prevent bounce, fitted with trailed linkage to ensure parallel, even brush wear. Three speed control (nominally 200 / 250 / 300 RPM). Optional brush pressure control is available if required.

HOPPER: 5.5 m³ Gross Hopper Volume* offering a 4.7 m³ Hopper Payload Volume*. Totally constructed from corrosion and abrasion resistant stainless steel, the hopper is fitted with large access doors on either side and a reinforced rear door with heavy-duty seals. The rear door incorporates an automatic closure system which clamps the door at 3 points for a watertight seal and body-drain facility for removal of excess water.

All inlet tubes are fitted with automatic blanking flaps and an easy-to-clean swing-down filter screen is mounted in the top of the hopper immediately below the suction fan. A storage compartment is provided, located on right hand side of the body.

The hopper is tipped by means of a two-stage tipping ram facilitating rapid load discharge.

* Scarab hopper capacities are calculated in accordance with European Standard EN15429

ACCESS DOORS: Large doors fitted each side of the hopper for hand loading bulky items.

HYDRAULIC SYSTEM: The hydraulic system is piped in zinc plated steel tubing, where practical, and is protected by 10-micron filters to ensure long component-life. The system's oil is cooled via a heat exchanger with a hydraulically driven high-performance fan, ensuring optimum cooling under the most arduous working conditions and high ambient temperatures. The hydraulic control valves are located for easy servicing in a protected compartment, all services being operated from the in-cab control panels.

WATER PUMP: Twin diaphragm self-priming water pump fitted with suction filter, driven by a direct-drive hydraulic motor. Solenoid valves operated from the main control panel direct water supply to the brushes and suction nozzles. Output is rated at 36 litres/minute @ 50 psi (3.5 bar).

WANDER HOSE: A lightweight flexible four metre long suction hose of 150 mm diameter, complete with aluminium extension tube and adjustable handle for cleaning awkward areas or gullies. Quick release wander hose points are located at either side of the rear door. The wander hose can be used simultaneously with sweeping or on its own for more powerful suction. Optional rear-mounted overhead boom with aluminium or steel gully entry tube can be fitted if required.

HYDRAULIC TANK: Located adjacent to the oil cooler, 15 litre capacity, with 10 micron return filter, air breather, suction strainer, and sight glass with automatic low-level shut off.

PNEUMATIC SYSTEM: The pneumatic system is connected to the vehicle auxiliary air supply, and is fitted with a pressure regulator, filter / water separator and pneumatic solenoid valves to control the side brush, wide sweep brush, suction nozzle, and gear change. The pneumatic valves are located for easy servicing in a protected compartment.

CANbus CONTROL PANELS: Scarab's tried and tested CANbus system, in service since 2003, has been developed to take advantage of the latest chassis technology and has proved to be a successful and welcome innovation. An ergonomically designed panel adjacent to the driver's seat contains all controls for operating the suction fan, brushes, hopper, work lights and water sprays. The panel is also capable of displaying operating data such as Fan speed, Distance and Hours Swept and provides system diagnostics and fault-finding checks on sweeping functions. An additional satellite control box for frequently used operations is mounted conveniently to hand.

WATER TANK: 900 litre gross capacity manufactured from corrosion resistant glass reinforced plastic and fitted with a large lid to facilitate cleaning. Filling is achieved by means of a hydrant connection with regulation air break, or alternatively by means of hose pipe. The tank is fitted with a clear sight glass with level indicator and suction strainers for the water pumps.

PAINTING: Two pack system single colour, optional multi colour and sign-writing.

SWEEPING WIDTHS:

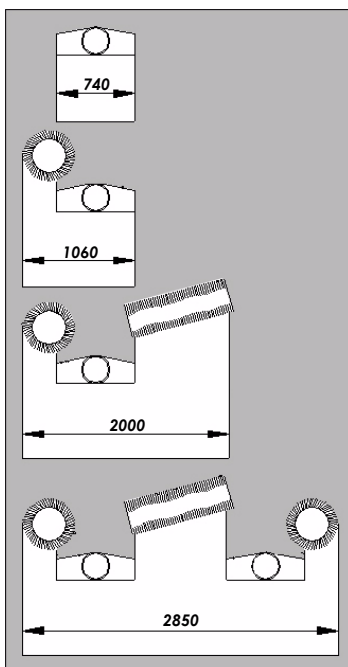

SUCTION NOZZLE ONLY

The suction nozzle, side brush and wide sweep brush can be raised or lowered independently of each other. This provides various sweeping patterns to suit differing road conditions.

SUCTION NOZZLE & SIDE BRUSH

SUCTION NOZZLE, SIDE BRUSH & WIDESWEEP

BOTH NOZZLES, BOTH SIDE BRUSHES & WIDESWEEP

On dual sweep machines the Scarab Merlin has the option of operating with both side brushes and nozzles simultaneously to give an unrivalled sweeping width.

CHASSIS SUITABILITY:

The Scarab Merlin Unidrive can be mounted on a range of chassis. For details of suitable chassis specifications please contact the Sales Department.

TYPICAL WEIGHT DATA:

SINGLE SWEEP CONFIGURATION		DUAL SWEEP CONFIGURATION	
Scarab Equipment Weight	2105 kg	Scarab Equipment Weight	2265 kg
DAF LF 45-160 7.5 tonne chassis	3102 kg	DAF LF 45-160 7.5 tonne chassis	3102 kg
IVECO ML75E16K 7.5 tonne chassis	2995 kg	IVECO ML75E16K 7.5 tonne chassis	2995 kg

Single sweep configuration includes fixed widesweep.

Dual Sweep configuration includes swivelling widesweep

Chassis weights quoted correct at time of publication and are subject to specification and manufacturers' tolerances

TYPICAL PAYLOAD FIGURES

EQUIPMENT SPECIFICATION	PAYLOAD*
Single Sweep (including Wander Hose and Fixed Widesweep Brush)	2400 kg
Dual Sweep (inc. Wander Hose, Swivelling Widesweep & H-P Water Pump)	2190 kg

Figures based upon Iveco ML75 16K 7.5 tonne Euro 4 chassis

* Payload predictions are subject to variance according to chassis/sweeper specification.

TYPICAL DIMENSIONAL DATA:

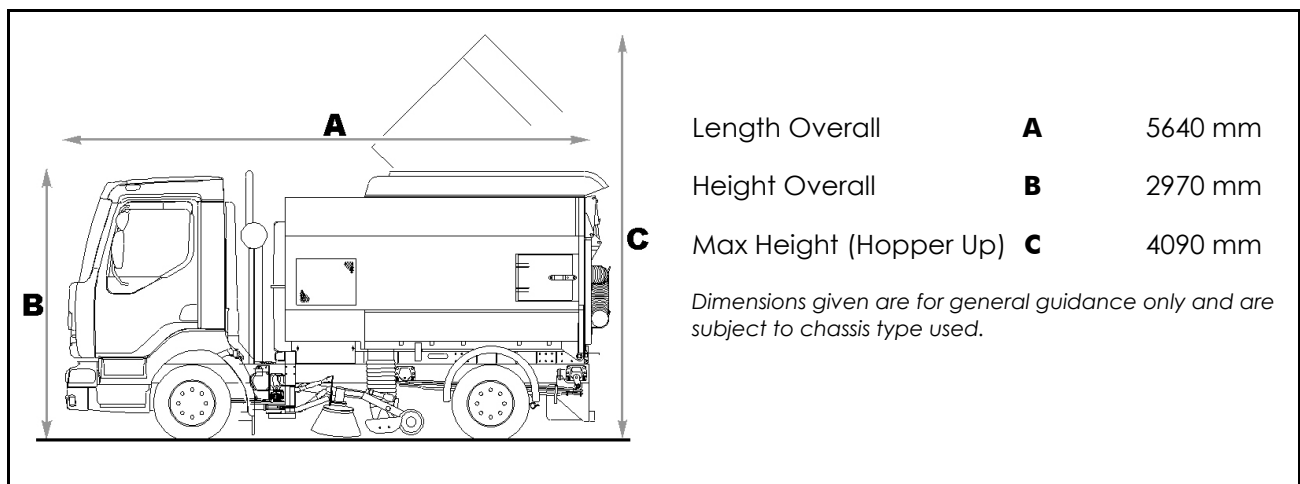

OPTIONS:

A comprehensive range of options, including a high-pressure water system and dual sweep, is available for the Merlin XP, please contact the Sales Department for further information.

Scarab Sweepers are dedicated to continuous product development and as such we reserve the right to change this specification without prior notice.
To ensure latest information contact Sales Department.



Pattenden Lane, Marden, Tonbridge, Kent. TN12 9QD

Telephone: 01622 831006

Fax: 01622 832417

E-Mail: scarab@scarab-sales.com

Web Site: www.scarab-sweepers.com

Issue - March 2008 / E & OE